

Castex®

GTC-170

Electric Grout Scrubber

Model No.:
608245

Operator and Parts Manual

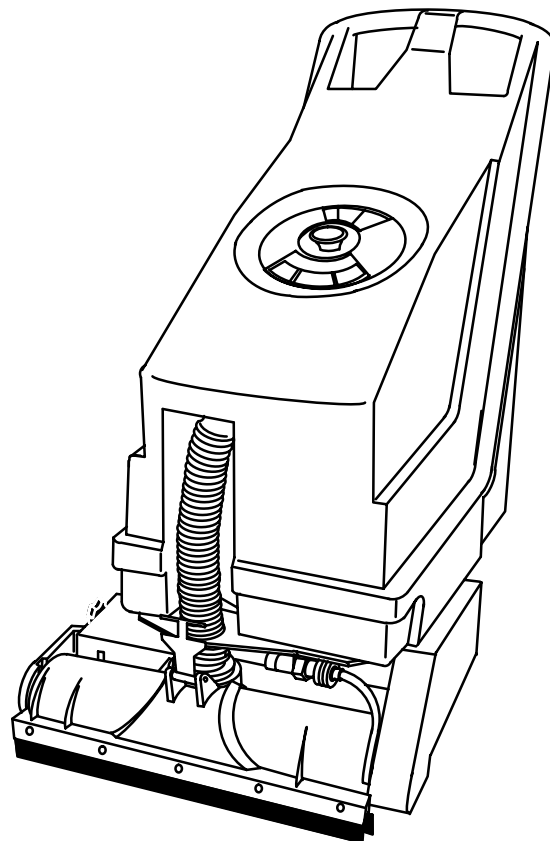

CASTEX INCORPORATED
12875 RANSOM STREET
HOLLAND MI 49424 U.S.A.

A TENNANT COMPANY

1-800-522-7839
616-786-2330
FAX: 1-800-678-4240
CUSTOMER SERVICE: 1-800-964-9644

608247
Rev. 00 (07-99)

OPERATION

This manual is furnished with each new model. It provides necessary operation and maintenance instructions.

Read this manual completely and understand the machine before operating or servicing it.

When ordering replacement parts, use the Parts Lists in this manual. Before ordering parts or supplies, be sure to have your machine model number and serial number handy. Parts and supplies may be ordered by phone or mail from any Authorized Service Center or Distributor.

This machine will provide excellent service. However, the best results will be obtained at minimum costs if:

- The machine is operated with reasonable care.
- The machine is maintained regularly - per the maintenance instructions provided.
- The machine is maintained with manufacturer supplied or equivalent parts.

MACHINE DATA

Please fill out at time of installation for future reference.

Model No.- _____

Install. Date - _____

Serial No.- _____

©1999 Castex®, A Tennant Company

Printed in U.S.A

TABLE OF CONTENTS

SAFETY PRECAUTIONS	3	MACHINE MAINTENANCE	11
SPECIFICATIONS	4	STORING MACHINE	16
MACHINE COMPONENTS	5	ATTACHMENT OPTIONS	17
TRANSPORTING MACHINE	7	TROUBLE SHOOTING	19
FILLING THE SOLUTION TANK	7	PARTS LIST	20
MACHINE OPERATION	8	ELECTRICAL DIAGRAM	31
DRAINING THE SOLUTION TANK	10	OPTIONS	32

SAFETY PRECAUTIONS

This machine is suited to scrub floors in an indoor environment and is not constructed for any other use. Use only recommended brushes and cleaning solutions.

All operators must read, understand and practice the following safety precautions:

The following safety alert symbols are used throughout this manual as indicated in their description.

⚠ WARNING: To warn of hazards or unsafe practices which could result in severe personal injury or death.

FOR SAFETY: To identify actions which must be followed for safe operation of equipment.

The following information signals potentially dangerous conditions to the operator or equipment:

FOR SAFETY:

1. **Do not operate machine:**
 - Unless trained and authorized.
 - Unless operator manual is read and understood.
 - In flammable or explosive areas unless designed for use in those areas.
 - Unless cord is properly grounded.
 - With damaged cord or plug.
 - If not in proper operating condition.
 - In outdoor areas.
 - In standing water.
2. **Before operating machine:**
 - Make sure all safety devices are in place and operate properly.
3. **When using machine:**
 - Do not run machine over cord.
 - Do not pull machine by plug or cord.
 - Do not pull cord around sharp edges or corners.
 - Do not unplug by pulling on cord.
 - Do not stretch cord.
 - Do not handle plug with wet hands.
 - Keep cord away from heated surfaces.
 - Report machine damage or faulty operation immediately.

4. **Before leaving or servicing machine:**
 - Turn off machine.
 - Unplug cord from wall outlet.
5. **When servicing machine:**
 - Unplug cord from wall outlet.
 - Avoid moving parts. Do not wear loose jackets, shirts, or sleeves.
 - Use manufacturer supplied or approved replacement parts.

⚠ WARNING: Hazardous Voltage. Shock or electrocution can result. Unplug machine before servicing.

⚠ WARNING: Flammable materials can cause an explosion or fire. Do not use flammable materials in tank(s).

⚠ WARNING: Flammable materials or reactive metals can cause an explosion or fire. Do not pick up.

GROUNDING INSTRUCTIONS

Machine must be grounded. If it should malfunction or breakdown, grounding provides a path of least resistance for electrical current to reduce the risk of electrical shock. This machine is equipped with a cord having an equipment-grounding conductor and grounding plug. The plug must be plugged into an appropriate outlet that is properly installed in accordance with all local codes and ordinances. Do not remove ground pin; if missing, replace plug before use.

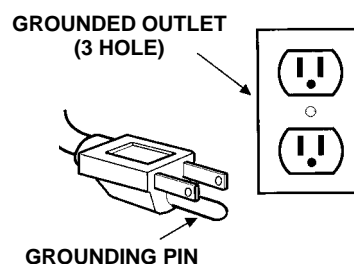

OPERATION

SPECIFICATIONS

POWER TYPE

Electric AC, 110 VAC, 60 HZ

POWER TRAIN

Electric motor, belt driven brush

Electric motor, vacuum fan

Electric motor, solution pump

PROPELLING SYSTEM

Manually propelled with brush assist in forward

SUSPENSION SYSTEM

Casters – (2) rear, 150 mm (6 in) dia

SYSTEM REFILL FLUID CAPACITIES

Combined Solution/Recovery tank – 30.3 L (8 gal)

GENERAL MACHINE DIMENSIONS

Length – 760 mm (30 in)

Width – 510 mm (20 in)

Height – 890 mm (35 in)

Squeegee width – 470 mm (18.5 in)

Cleaning path width – 430 mm (17 in)

Brush width – 430 mm (17 in)

Brush diameter – 90 mm (3.5 in)

Power cord – 1015 mm (40 ft)

MACHINE WEIGHT

Empty solution tank – 48 kg (107 lb)

Full solution tank – 73.9 kg (163 lb)

Shipping Weight – 51.7 kg (114 lb)

MACHINE COMPONENTS

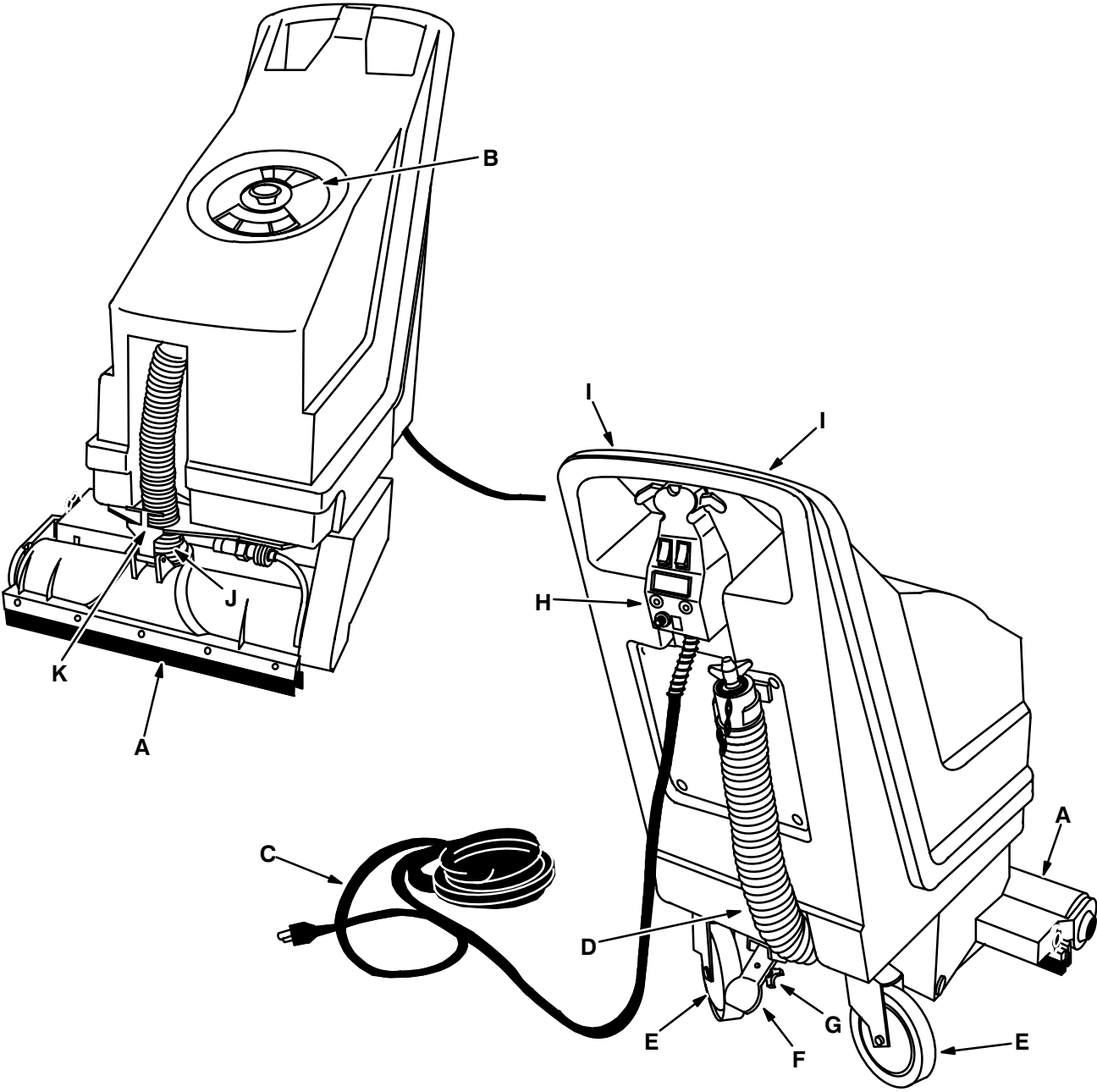

- A. Scrub Head
- B. Solution Tank Cover
- C. Power Cord
- D. Drain Hose
- E. Rear Caster
- F. Scrub Head Lift Lever

- G. Brush Down Pressure Knob
- H. Control Panel
- I. Machine Handle
- J. Squeegee Height Adjustment Ring
- K. Double Scrub Latch

OPERATION

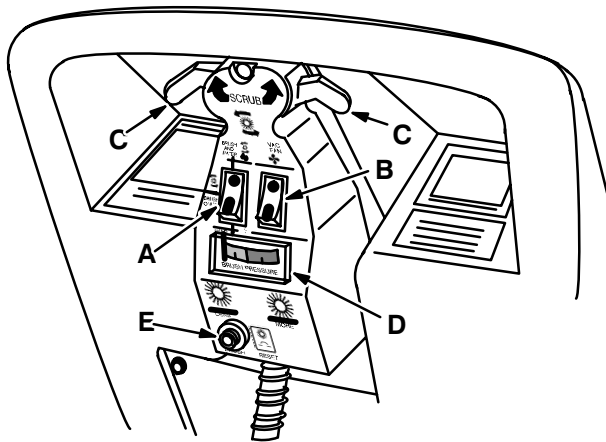

CONTROL PANEL

- A. Mode Switch**
- B. Vacuum Fan Switch**
- C. Brush/Solution Lever(s)**
- D. Brush Pressure Gauge**
- E. Brush Circuit Breaker**

MODE SWITCH:

The mode switch controls various scrubbing functions.

For normal scrub operation, place the mode switch in the BRUSH AND WATER (TOP) position. In this position, both brush and solution pump will operate when either brush/solution lever is activated. Both functions will stop when the lever(s) are released.

For double scrub operation, place the mode switch in the BRUSH ONLY (CENTER) position. When the lever(s) are activated, only the brush will operate; solution will not flow.

For attachment option use, place the mode switch in the WAND (BOTTOM) position. Only the solution pump will operate in this position.

NOTE: Make sure solution dispensing tube is disconnected from the female quick disconnect, or the option is attached to female quick disconnect, otherwise solution will immediately begin to flow onto the floor until the tank is emptied.

VACUUM FAN SWITCH:

The vacuum fan switch controls the vacuum fan. Press the bottom (I) of the switch to turn on the vacuum fan. Press the top (O) of the switch to turn off the vacuum fan.

BRUSH/SOLUTION LEVER(S):

The machine has two levers under the machine handles at the top of the control panel. The brush/solution lever(s) turn on the scrub brush and the solution pump. One or both of the levers can be used to start the scrub brush and solution pump when the MODE switch is in the BRUSH AND WATER position. Only the brush will run when the lever(s) are operated if the MODE switch is in the BRUSH ONLY position. In the WAND position, neither the brush nor solution pump are activated by the lever(s).

BRUSH PRESSURE GAUGE:

The brush pressure gauge indicates the pressure of the scrub brush on the floor. The brush pressure needle should be at the top of the green zone for the best scrubbing results.

BRUSH CIRCUIT BREAKER:

The brush circuit breaker protects the brush motor from overload. If the brush pressure is too high, the brush circuit breaker will trip and the scrub brush will stop. To reset the brush circuit breaker, press the circuit breaker reset button on the circuit breaker. It may be necessary to allow the circuit breaker to cool down before resetting, or it may trip again. Reduce the brush pressure before resuming scrubbing and check the brush for obstructions.

SCRUB HEAD LIFT LEVER:

The scrub head lift lever raises the scrub head off the floor. Raise the scrub head with the scrub head lift lever when transporting the machine from place to place, and when the machine is not being used. To raise the scrub head, step on the scrub head lift lever. To lower the scrub head, pull the lever up with the toe of your shoe.

BRUSH DOWN PRESSURE KNOB:

The brush down pressure knob adjusts the pressure of the scrub brush against the floor. The brush down pressure knob is located on the underside of the scrub head lift lever. To increase the scrub brush pressure, turn the pressure knob to the left. To decrease the scrub brush pressure, turn the knob to the right.

SQUEEGEE HEIGHT ADJUSTMENT RING:

The squeegee height adjustment ring adjusts the height of the front and back sets of squeegees located on the scrub head. The adjustment ring is located at the top of the scrub head. Turning the adjustment ring adjusts the height and deflection of the squeegees for proper water pickup. Turn the adjustment ring to the left to increase deflection, and to the right to decrease deflection.

DOUBLE SCRUB LATCH:

The double scrub latch locks the squeegees up. The lever is located on the front of the scrub. Pull up on the lever and hook it onto the frame above the scrub head.

PRE-OPERATION CHECKLIST

Check power cord for any wear or damage. Do not operate machine with a damaged cord.

TRANSPORTING MACHINE

To move the machine from one place to another, raise the scrub head with the scrub head lift lever. This makes maneuvering the machine easier. When the machine is sitting and not being used, raise the scrub head. This prevents the brush from getting a flat spot. To raise the scrub head, step on the scrub head lift lever until it locks into position. To lower the scrub head, pull up on the scrub head lift lever with the toe of your shoe.

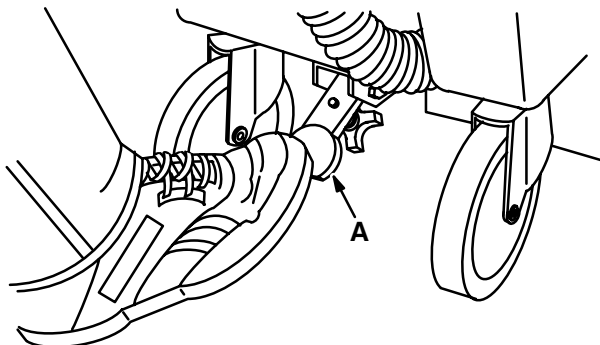

RAISING THE SCRUB HEAD

A. Scrub Head Lift Lever

FILLING THE SOLUTION TANK

1. Unplug the machine and move the machine next to a water source.

⚠ WARNING: Hazardous voltage. Shock or electrocution can result. Unplug power cord before servicing.

2. Remove the solution tank cover, letting it hang on the side of the machine.
3. Using a clean bucket or hose, partially fill the tank with hot water through the fill opening.

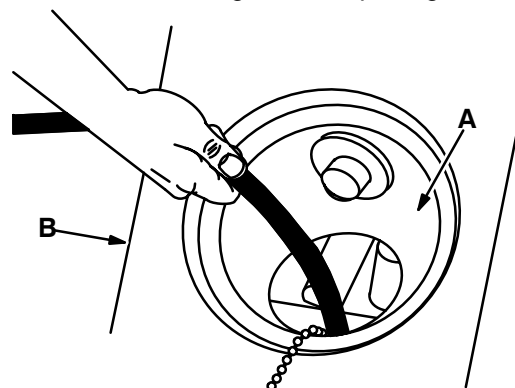

FILLING THE SOLUTION TANK

A. Fill Opening

B. Solution Tank

ATTENTION: Do not use water hotter than 60° C (140° F) in the solution tank or tank damage may occur.

4. Pour the specified amount of detergent into the solution tank. Use manufacturer-supplied detergents for best results. Do not use more detergent than is recommended for the job. Powdered detergents are not recommended.

⚠ WARNING: Flammable materials can cause an explosion or fire. Do not use flammable materials in solution tank.

OPERATION

- Fill the solution tank with water up to the bottom link of the chain hanging inside the tank. **DO NOT OVERFILL** or damage to the vacuum motor may occur.

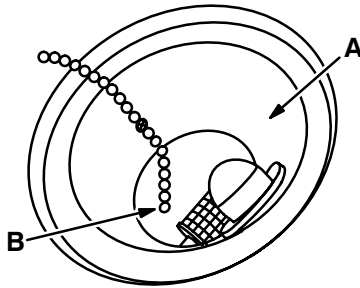

FILL LEVEL OF SOLUTION TANK

- A. Fill Opening
- B. Bottom Of Fill Chain

NOTE: If the area to be cleaned already has puddles of standing water (such as swimming pool decks), **DO NOT COMPLETELY FILL** the solution tank. Picking up excess water will cause the solution tank to overflow and solution may enter and damage the vacuum motor.

- Place the solution tank cover on the solution tank and make sure the cover gasket seals the tank.

MACHINE OPERATION

PRE-OPERATION

- Sweep or dust mop the entire area to be scrubbed. Loose objects or debris will plug squeegee openings and cause streaking and poor water pickup.
- Remove gum or other such materials stuck to the floor with a putty knife or scraper.
- Determine which cleaning mode is best for the floor condition, *normal scrub* or *double scrub*.

NORMAL SCRUBBING OPERATION

- Plug the machine into a wall outlet.
- Set the MODE switch to the BRUSH AND WATER (TOP) position.
- Turn on the vacuum fan switch.
- Lower the scrub head by pulling up on the scrub head lift lever with the toe of your shoe.
- Pull up on both or one of the switch levers and proceed to scrub. The machine can be pushed and pulled like a vacuum cleaner.

⚠ WARNING: Flammable materials or reactive metals can cause an explosion or fire. Do not pick up.

- Watch the water pick up of the machine. If the machine is leaving water on the floor, adjust the squeegees as follows:

Push the machine forward. Look at the front set of squeegees. The inside squeegee should be straight up and down and touch the floor. The outside squeegee will bend over and touch the inside squeegee.

The same applies for the rear set of squeegees when the machine is pulled backward. The inside squeegee should be straight up and down and touch the floor. The outside squeegee will bend over and touch the inside squeegee.

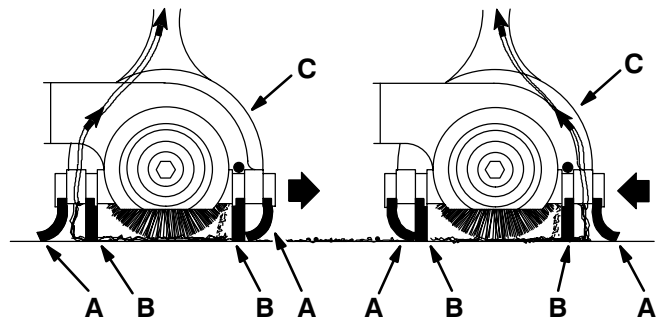

SQUEEGEE ADJUSTMENT

- A. Outside Squeegee Blade
- B. Inside Squeegee Blade
- C. Scrub Head

Both squeegees are adjusted at the same time. To adjust the squeegees, use the squeegee height adjustment ring located on the top of the scrub head. Turn the adjustment ring until the squeegees are adjusted as shown. Pull the machine back and push the machine forward checking the adjustment of the squeegees.

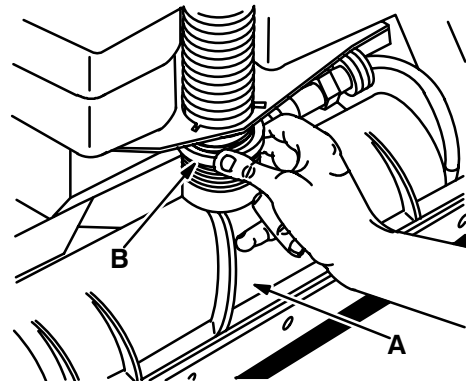

SQUEEGEE HEIGHT ADJUSTMENT RING

- A. Scrub Head
- B. Squeegee Height Adjustment Ring

Squeegee adjustment is more precise if the floor is wet with cleaning solution. **DO NOT APPLY TOO MUCH PRESSURE** or the squeegees will smear the floor and wear prematurely.

- Pull up on one or both of the brush/solution levers to check the brush pressure.

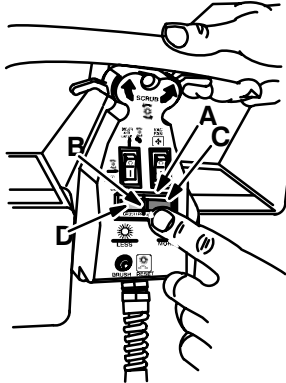

BRUSH PRESSURE GAUGE

- A. Brush Pressure Gauge**
- B. Brush Pressure Gauge Needle**
- C. Red Zone**
- D. Green Zone**

The brush pressure gauge needle should be at the top of the green zone. If necessary, adjust the brush pressure with the brush down pressure knob until the brush pressure needle reads at the top of the green zone. The adjustment works better if the floor is wet with cleaning solution.

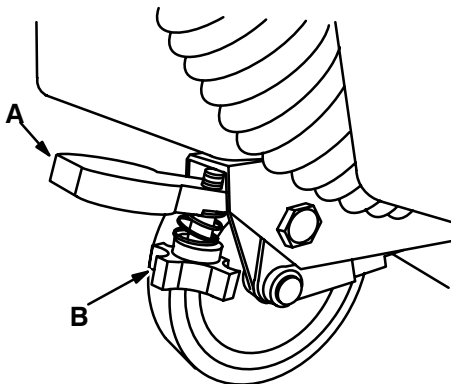

BRUSH DOWN PRESSURE KNOB

- A. Scrub Head Lift Lever**
- B. Brush Down Pressure Knob**

- Pull up on both or one of the switch levers and proceed to clean. The machine can be pushed and pulled like a vacuum cleaner. The recommended scrubbing path is pushing the machine forward, overlapping paths, much like mowing a lawn.

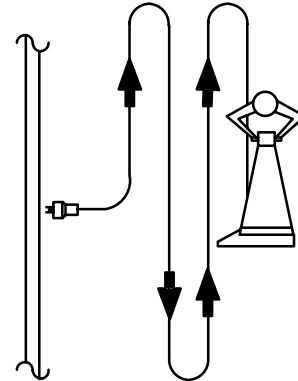

SCRUBBING WITH MACHINE

- When cleaning next to walls or under kickboards, use the operator's right side of the machine for closer scrubbing.
- Watch for foam buildup in the tank through the clear tank cover. If the foam starts rising into the fill area of the solution tank, shut off the machine. Add defoamer to the solution tank, or drain some of the solution from the tank and add clean water.

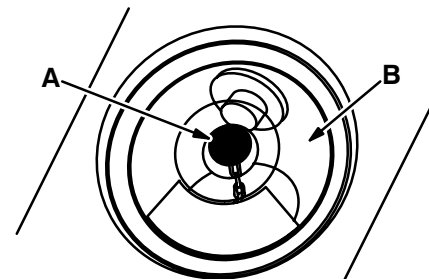

FOAM IN FILL AREA

- A. Solution Tank Cover**
- B. Fill Area**

- When finished scrubbing, turn off the vacuum fan switch and raise the scrub head by stepping on the scrub head lift lever.

OPERATION

DOUBLE SCRUBBING

Double scrubbing means running the machine over an area several times to get extra scrubbing action. In the double scrub operation, the brush will operate by activating the brush/solution lever(s), but no additional cleaning solution will be applied.

1. Set the MODE switch in the BRUSH ONLY (CENTER) setting.
2. Turn OFF the vac fan switch.
3. Lift up on the double scrub latch and hook it into the machine frame above the scrub head to keep the squeegee blades off the floor.

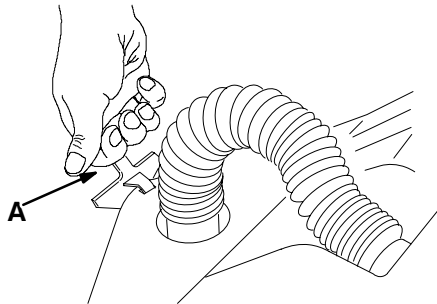

LIFTING UP SCRUB HEAD

A. Double Scrub Latch

4. With the scrub head on the floor, pull up on the brush/solution lever(s) and go slowly over the area you wish to double scrub as many times as necessary. In the double scrub mode, no further cleaning solution will be dispensed.
5. When you have completed double scrubbing, turn on the vacuum fan, and go over the area to vacuum up the solution.
6. When finished scrubbing, turn off the vacuum fan switch and raise the scrub head by stepping on the scrub head lift lever.

DRAINING THE SOLUTION TANK

1. Unplug the power cord from the wall outlet and place the machine next to a floor drain.

⚠ WARNING: Hazardous voltage. Shock or electrocution can result. Unplug machine before servicing.

2. Pull the drain hose from the retaining clip on the back of the machine.

3. Loosen the drain plug by turning the drain plug knob to the left.
4. Remove the drain plug while holding the hose up. Quickly lower the hose to the floor drain, as the solution rushes out of the drain hose. Flow rate can be reduced by squeezing the hose.

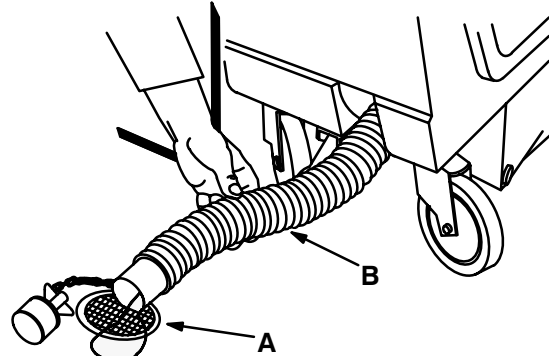

DRAINING THE SOLUTION TANK

A. Floor Drain

B. Drain Hose

5. With the hose open, flush out the inside of the tank with clean water. Make sure the screen filter at the bottom of the tank is rinsed completely. The filter may be removed for better cleaning by unscrewing it from the fitting. **MAKE SURE THE FILTER IS INSTALLED PRIOR TO USING THE MACHINE AGAIN.** Do not overtighten filter in fitting.

NOTE: Do not use water hotter than 60° C (140° F) in the solution tank or tank damage may occur.

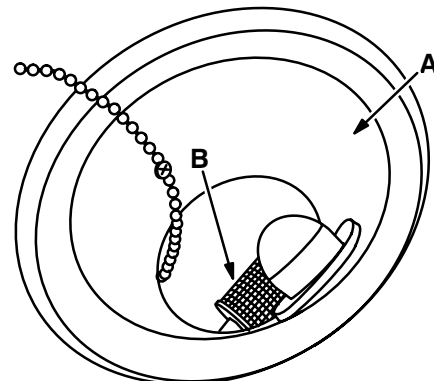

SCREEN FILTER

A. Solution Tank

B. Screen Filter

- Pull the vacuum inlet filter out of the side of the fill area and rinse the filter with clean warm water. Push the inlet filter back into the fill area making sure the screen is facing down into the tank.

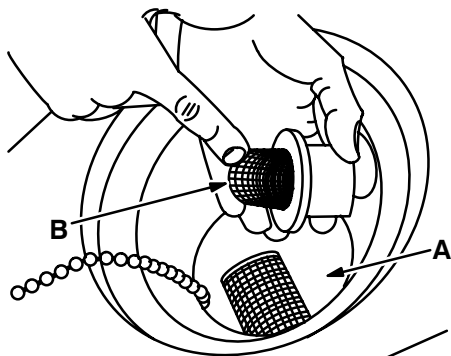

VACUUM INLET FILTER

- A. Fill Area**
- B. Vacuum Inlet Filter**

- When the solution tank is completely drained and flushed, place the drain plug back into the end of the drain hose and turn the end of the drain plug to the right to tighten the plug. Place the drain hose back into the retaining clip on the back of the machine.

POST-OPERATION CHECKLIST

Check this list of items over after operating the machine:

- Check power cord for wear or damage. Repair or replace if required. Wipe cord clean and wrap around the machine handles.
- Raise the scrub head by stepping on the scrub head lift lever.
- Flush squeegee housing with hot water, especially if the machine is used in greasy areas.
- Wipe grease/debris buildup from squeegee and squeegee nozzles.
- Check for and remove any string or material wrapped around the scrub brush.
- Check the solution dispensing tube for any plugged holes.
- Check the squeegees for wear or any damage. Replace any worn or damaged squeegees.
- Push the machine to an area to be kept until it is needed again. Be sure the scrub head is raised.

- Freeze protect machine if it will be stored or transported in areas where solution in the system may freeze and damage the components. See *FREEZE PROTECTION* under *STORAGE INFORMATION*.

MACHINE MAINTENANCE

The *DAILY*, *WEEKLY*, and *MONTHLY* maintenance requirements listed here may be performed without tools by the machine operators. Instructions for these maintenance requirements are provided in this section of the manual.

The *EVERY SIX MONTHS* maintenance requirements should only be performed by trained technicians.

FOR SAFETY: When servicing machine, unplug cord from wall outlet.

DAILY

- Perform all duties listed under *PRE-OPERATION* and *POST-OPERATION* check lists.
- If machine is to be transported or stored under freezing conditions, machine (and any options) must be freeze protected. See *FREEZE PROTECTION* under *STORAGE INFORMATION*.

WEEKLY

- Flip the scrub brush end-for-end to prevent a “set” and increase life.
- Remove and clean/flush solution dispensing tube.
- Remove and clean/flush solution screen filter in the solution tank.

MONTHLY

- Remove scrub head from machine and thoroughly clean.
- Check the scrub brush for wear; replace brush if remaining bristles measure less than 20 mm (0.62 in) in length.

EVERY THREE MONTHS

- Lubricate brush housing pivot pins/bearings with light oil.
- Check and tighten all fasteners/hardware.

OPERATION

EVERY SIX MONTHS

Six month and yearly maintenance is recommended to be performed by technicians from your authorized Service Center. Six month maintenance includes weekly and monthly maintenance, plus:

1. Vacuum motor brush inspection.
2. Brush motor carbon brush inspection.
3. Solution pump carbon brush inspection.
4. Brush bearing/seal inspection/replacement.
5. Check brush drive belt alignment/wear. Replace belt if required.

SCRUB HEAD

The scrub head encloses the scrub brush, a solution dispensing tube, a set of squeegee blades mounted on the front and rear. The scrub head and squeegee blades should be flushed daily to remove soil buildup, especially grease, and obstructions.

DAILY FLUSHING OF SCRUB HEAD:

1. Unplug the power cord from the wall outlet.

⚠ WARNING: Hazardous voltage. Shock or electrocution can result. Unplug machine before servicing.

2. Raise the scrub head by stepping on the scrub head lift lever with your foot.
3. Position the machine over a floor drain next to a hot water supply with a hose.
4. Disconnect the vacuum pick up hose from the solution tank inlet.

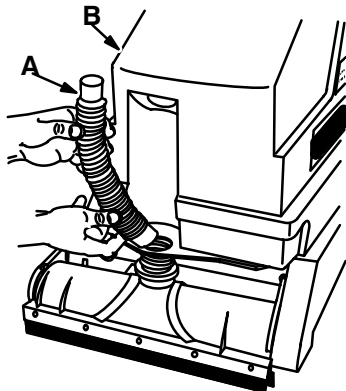

DISCONNECT VACUUM PICK UP HOSE

- A. Vacuum Pick Up Hose
- B. Solution Tank

5. Using hot water under normal water pressure, insert water hose into the top of the scrub head and allow the water to flush out the housing and blade area.

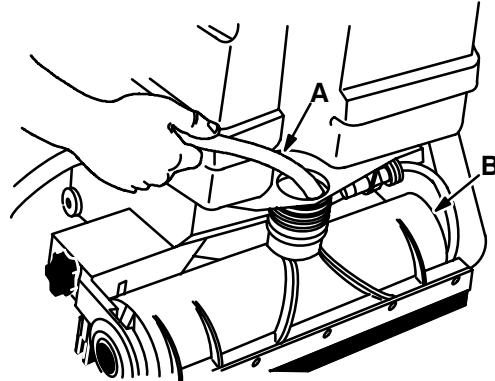

FLUSHING SQUEEGEE HOUSING

- A. Hose
- B. Scrub Head

6. With a wet cloth, wipe off all four (4) squeegee blades to prevent grease buildup. At the same time, inspect each blade for wear or damage. Replace if required.

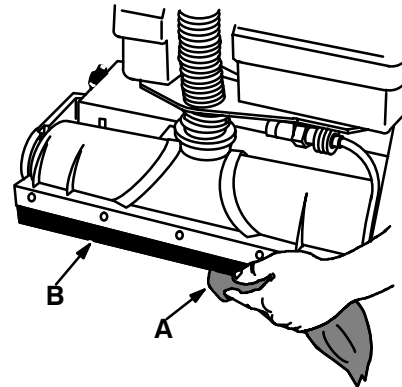

CLEANING SQUEEGEE BLADES

- A. Cloth
- B. Squeegee Blade

7. Re-install vacuum pickup hose on machine.

MONTHLY CLEANING OF SCRUB HEAD:

The scrub head should be thoroughly cleaned monthly. Lubricate the pivot pins and bearings at the same time.

1. Unplug the power cord from the wall outlet.

⚠ WARNING: Hazardous voltage. Shock or electrocution can result. Unplug machine before servicing.

- Remove the scrub head assembly from the machine.
- Flush the scrub head under clean water. Run water in between the squeegee blades to flush out the vacuum inlets.

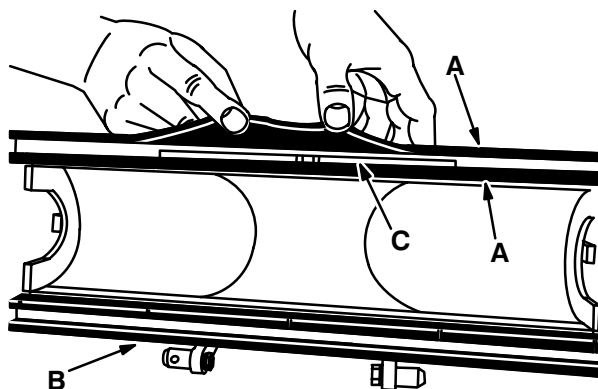

SCRUB HEAD VACUUM INLETS

- A. Squeegee Blades**
- B. Scrub Head**
- C. Vacuum Inlets**

- Flush the dispensing tube with clean hot water.
- Place the scrub head back in place on the machine. Pull down on the spring located above the squeegee height adjustment ring and slip the top of the scrub head into the machine. The spring will center the scrub head in the vacuum inlet bracket.
- Push the side links back onto both sides of the scrub head. Every 3 months, lubricate pins and bearings with light oil.

SCRUB BRUSH

The scrub brush should be checked daily to remove any string or other material wrapped around it. The scrub brush should be flipped end-for-end every week to prevent the bristles from taking a "set" and to increase brush life. The brush should be changed when the remaining bristles measure 20 mm (0.62 in) or less in length.

REPLACING SCRUB BRUSH OR ROTATING AN OLD BRUSH:

- Unplug the machine and raise the scrub head by stepping on the scrub head lift lever with your foot.

⚠ WARNING: Hazardous voltage. Shock or electrocution can result. Unplug machine before servicing.

- Loosen the brush plate knob by turning to the left. Remove the brush plate knob from the side of the scrub head.

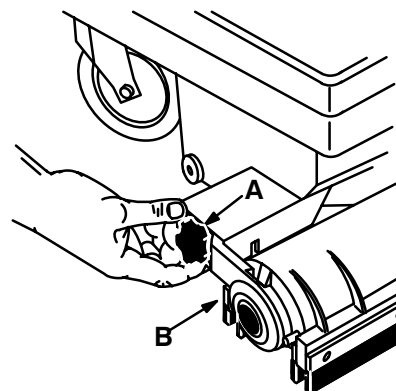

REMOVING BRUSH PLATE KNOB

- A. Brush Plate Knob**
- B. Scrub Head**

- Pull the brush plate off the side of the scrub head.

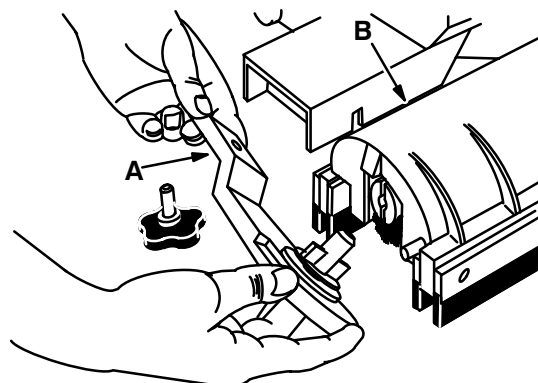

REMOVING BRUSH PLATE

- A. Brush Plate**
- B. Scrub Head**

- Pull the brush out of the scrub head.

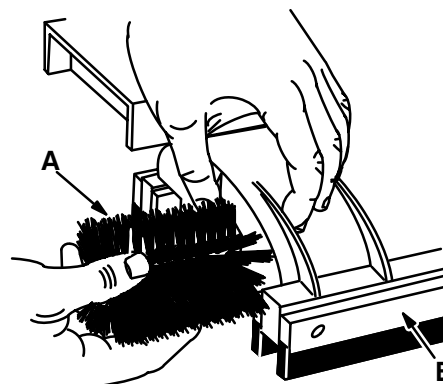

REMOVING BRUSH

- A. Brush**
- B. Scrub Head**

OPERATION

5. Push the new or flipped brush into the scrub head.
6. Line up the two slots in brush end with the two tabs on the brush plug on the drive end of the scrub head. Make sure the brush pushes all the way on the brush plug. If the brush does not engage properly on the brush plug, the brush plate will not mount to the machine.
7. Line up the brush plate plug with the end of the brush by putting the tabs on the plug in the brush slots. Place the brush plate knob in the brush plate and mount the brush plate to the side of the scrub head. Turn the brush plate knob to the right to tighten it.

SOLUTION DISPENSING TUBE

The solution dispensing tube is located at the front and on the inside of the scrub head. The small holes drilled in the tube evenly dispense the cleaning solution over the brush. The dispensing tube can be removed from the scrub head for cleaning if required. Clean the tube if the solution does not dispense evenly over the brush.

CLEANING THE DISPENSING TUBE:

1. Unplug the machine. Disconnect the solution feed hose from the quick disconnect by pulling back on the knurled sleeve of the female disconnect until the male fitting releases.

⚠ WARNING: Hazardous voltage. Shock or electrocution can result. Unplug machine before servicing.

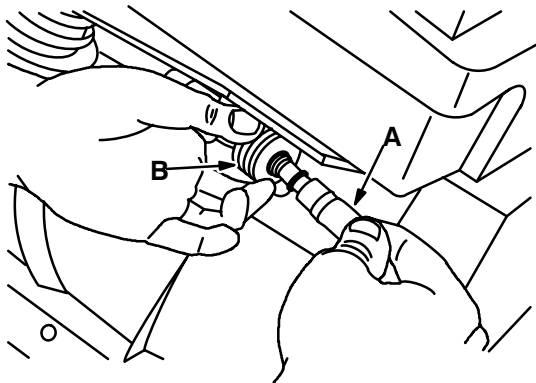

DISCONNECT SOLUTION HOSE

- A. Solution Hose
- B. Female Quick-disconnect

2. A small cap is located on the other end of the dispensing tube. To remove the dispensing tube from the scrub head pull the tube straight out of the scrub head. The small cap will pop off the end of the tube. DO NOT lose the cap. Pull the tube from the housing, taking care not to bend it.

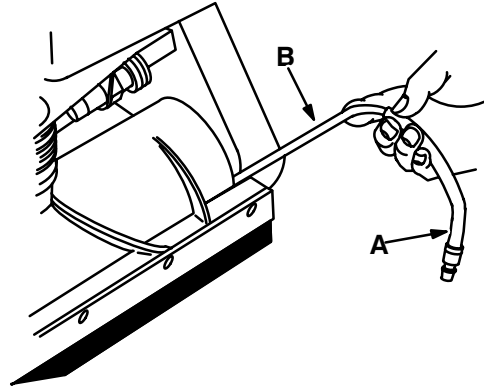

REMOVING DISPENSING TUBE

- A. Solution Hose
- B. Dispensing Tube

3. Clean the small dispensing holes with a piece of wire or a pin, and rinse the tube out with clean hot water.
4. Place the tube back in the scrub head.
5. Push the cap back on the other end of the tube. Make sure the cap fits tightly on the end of the dispensing tube.

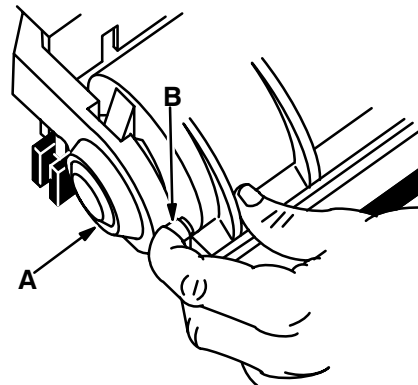

DISPENSING TUBE CAP

- A. Scrub Head
- B. Dispensing Tube Cap

6. Connect the solution hose male fitting to the female fitting by pulling back on the knurled sleeve on the female and inserting the male fitting. Release the sleeve and make sure the hose is properly connected by pulling lightly on it.

SOLUTION SCREEN FILTER

The solution filter filters the cleaning solution before reuse. The filter is normally flushed clean after every use during the tank flushing procedure. For more thorough cleaning on a periodic basis do as follows:

1. Unplug the power cord from the wall outlet.

⚠ WARNING: Hazardous voltage. Shock or electrocution can result. Unplug machine before servicing.

2. Remove cover from solution tank and hang from chain.
3. Reach into tank and unscrew the screen filter from fitting by turning to the left.
4. Using a hose with warm water under normal pressure, flush the filter from the inside out.

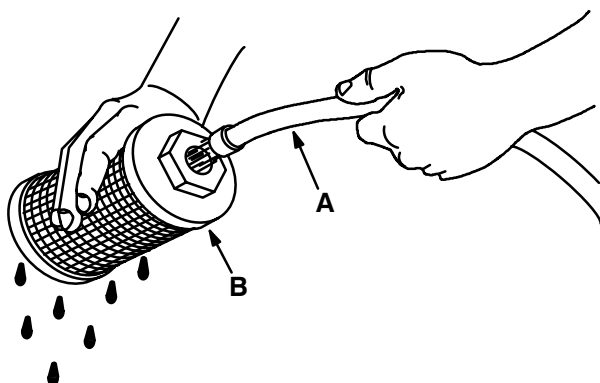

FLUSHING SOLUTION SCREEN FILTER

A. Solution Screen Filter

B. Hose

5. If filter screen material is excessively plugged, soak overnight in a solution of 1 part white vinegar to 10 parts water. Flush with water after soaking.
6. Place filter back on to threaded fitting and turn to the right. Do not overtighten.

NOTE: Take care not to damage the filter. Do not use a filter with a hole or tear. Damage may occur to the pump if the machine is operated without the filter in place or if the filter is removed before the tank is completely drained. **DO NOT ALLOW ANY DEBRIS INTO PUMP INTAKE LINE.**

REMOVING THE SCRUB HEAD ASSEMBLY

The following procedure is recommended if all squeegee blades are being replaced, and/or if the scrub head is being cleaned under the **MONTHLY CLEANING OF SCRUB HEAD**. It is recommended that the pivot pins and bearings be lubricated at the same time.

1. Unplug the power cord from the wall outlet.

⚠ WARNING: Hazardous voltage. Shock or electrocution can result. Unplug machine before servicing.

2. Remove the scrub brush.
3. Disconnect the solution hose quick disconnect.
4. Disconnect the vacuum pick up hose from the top of the scrub head.

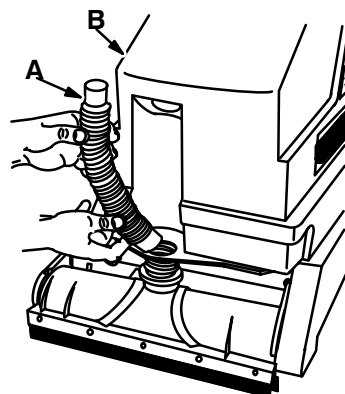

DISCONNECT VACUUM PICK UP HOSE

A. Vacuum Pick-up Hose

B. Solution Tank

5. Pull the side links off both sides of the scrub head.

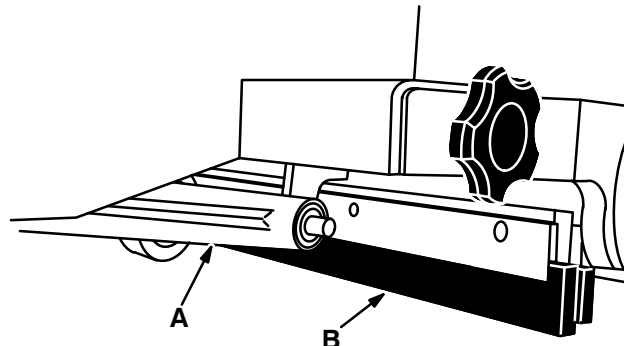

RIGHT SIDE SCRUB HEAD LINK

A. Scrub Head Link

B. Scrub Head

6. Pull the spring located above the squeegee height adjustment ring and remove the scrub head from the machine.
7. Turn the scrub head upside-down.
8. To reinstall the scrub head assembly, place the scrub head back in place on the machine. Pull down on the spring located above the squeegee height adjustment ring and slip the top of the scrub head into the machine. The spring will center the scrub head in the vacuum inlet bracket.
9. Push the side links back onto both sides of the scrub head. Every 3 months, lubricate pins and bearings with light oil.

OPERATION

10. Connect the solution hose quick disconnect.
11. Connect the vacuum pick-up hose to the top of the scrub head.
12. Install the brush in the scrub head.

SQUEEGEE BLADES

The scrub head has 2 sets of 2 squeegee blades on the front and back. These blades squeegee up the solution off the floor in the forward and reverse directions. The front and rear squeegee blades (with the many corrugations) should be checked for damage and wear daily. When the inside wiping edge of the front and rear (corrugated) blades become rounded or have tears in them, they will not pick up solution properly. Replace any worn or damaged squeegee blades. The inside squeegee blades (the ones with the slots) normally only need to be checked monthly.

REPLACING SQUEEGEE BLADES:

1. Unplug the power cord from the wall outlet.

⚠ WARNING: Hazardous voltage. Shock or electrocution can result. Unplug machine before servicing.

2. Raise the scrub head by stepping on the scrub head lift lever with your foot.
3. Grasp the end of the squeegee blade(s) that need replacing and pull it sideways out of the blade retainer. Use a dry cloth to grasp the squeegee blade if needed.

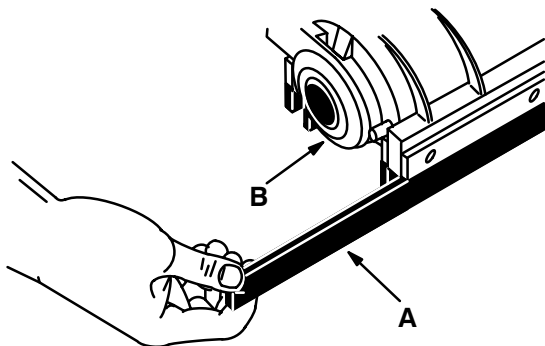

REMOVING SQUEEGEE BLADE

- A. Squeegee Blade
- B. Scrub Head

4. Lubricate new squeegee blade in water/detergent from tank. Pull new squeegee blade into the scrub head blade retainer until it is centered in the scrub head. Use a dry cloth if needed to grip squeegee while pulling it into retainer.
5. If all the squeegees need to be replaced, remove the scrub head assembly from the machine.

6. Pull out any squeegee blades that need replacing.

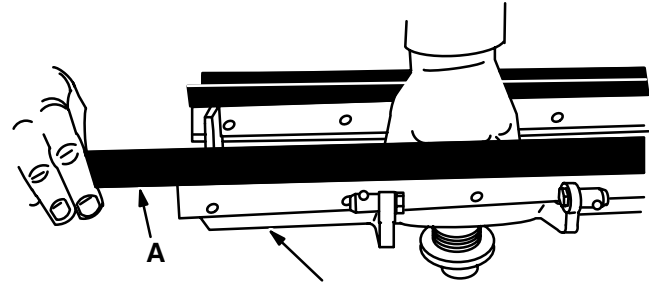

REMOVE SQUEEGEE BLADE

- A. Squeegee Blade
- B. Scrub Head

NOTE: Use a dry cloth to help get a grip on the squeegee blade end to pull the blade out of the scrub head.

7. Pull the new squeegee blade into the scrub head from the blades end until the blade is centered in the scrub head.

NOTE: Lubricate the new squeegee blade with some detergent to make pulling the blade into the scrub head much easier. Use a dry cloth to help get a grip on the squeegee blade end to pull the blade out of the scrub head.

8. Flush out the scrub head assembly and install it back on the machine.

STORING MACHINE

Freeze protection of the machine is necessary to prevent damage to components of the solution system when the machine is going to be exposed to freezing temperatures.

ATTENTION: Freezing temperatures can severely damage components. Do not store or transport machine in areas where freezing of solution contents could occur, unless machine is freeze protected. Failure of components due to lack of freeze protection voids the warranty on such components.

FREEZE PROTECTION

1. Pour 3.8 L (1 gal) of pre-mixed automotive-type windshield washer solution into solution tank.

ATTENTION: Do not use cooling system anti-freeze such as ethylene glycol.

2. Move machine over floor drain and plug the power cord into an outlet.

3. Set the MODE switch in the WAND position. The pump will start and spray through the feed tube to the floor. Run in this manner until all of the solution is dispensed.
4. Repeat the same process for any wand attachments that may freeze by attaching wand to the machine and opening the hand valve until all solution is dispensed.

ATTENTION: Machines and attachments that have been freeze protected must be flushed completely prior to normal use. Follow directions for the appropriate cleaning process, but run your selected cleaning solution through the system to purge all anti-freeze before starting the cleaning process.

ATTACHMENT OPTIONS

CONNECTING ATTACHMENTS TO THE MACHINE

NOTE: All attachments connect in the same way.

1. Attach male end of solution feed hose to the female quick-disconnect on the machine. Push the male connector in until it stops. Pull on the hose to make sure it is connected.

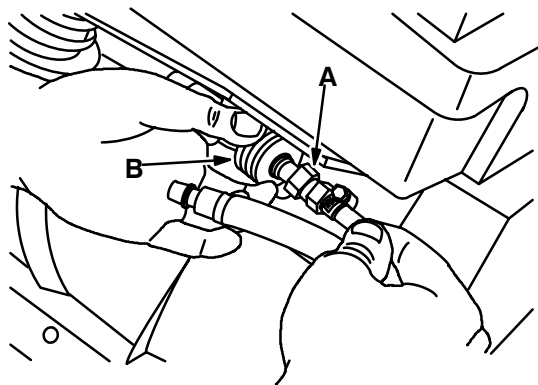

CONNECTING SOLUTION FEED HOSE

- A. Male Quick-Disconnect
- B. Female Quick-Disconnect

2. Pull the vacuum hose off the solution tank, and firmly insert the hose cuff from the wand attachment hose into the tank.

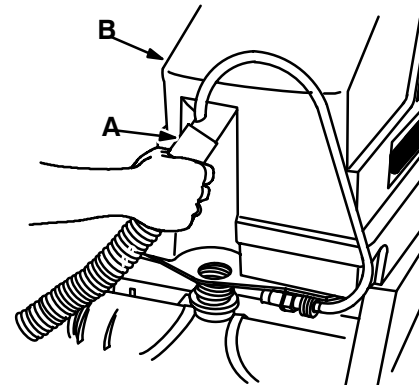

CONNECTING ATTACHMENT HOSE

- A. Wand Attachment Hose
- B. Solution Tank

3. Attach the other ends of the solution and vacuum hoses to the selected attachment tool in the same way.

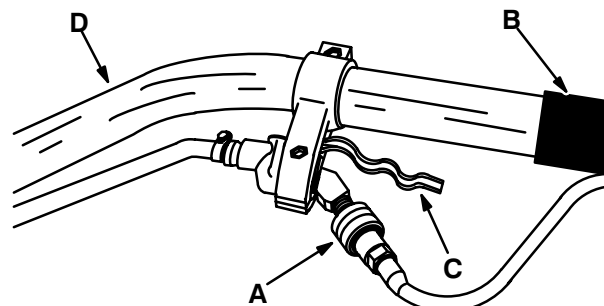

CONNECTING ATTACHMENT

- A. Solution Hose Quick-Disconnect
- B. Vacuum Hose
- C. Valve Handle
- D. Selected Attachment

4. Set the MODE switch to the WAND position. Turn the VAC switch to ON.
5. To disconnect the attachment, reverse the above steps.

OPERATION

USING THE ATTACHMENTS

The attachments only work properly by pulling them toward you, not pushing. Set the vacuum end of the tool on the surface and squeeze the valve lever. Immediately begin pulling the tool toward you, spraying the surface with detergent and immediately vacuuming up the solution.

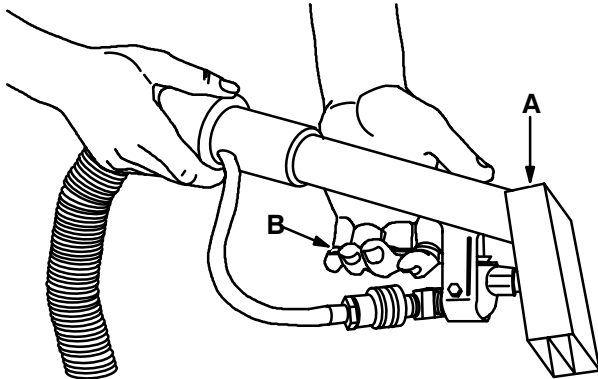

UPHOLSTERY/STAIR TOOL

- A. Upholstery Tool
- B. Valve Handle

To scrub with the hard floor wand, flip the cleaning tool so the brush is facing down.

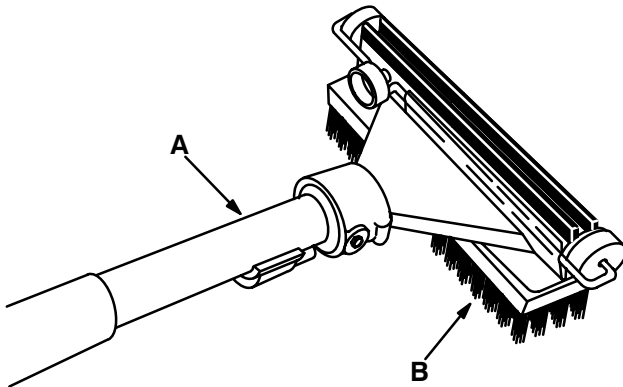

HARD FLOOR WAND

- A. Cleaning Tool
- B. Brush

To vacuum up the solution with the hard floor wand, flip the cleaning tool so the squeegee side is facing down. Push and/or pull the tool across the floor to pick up the solution.

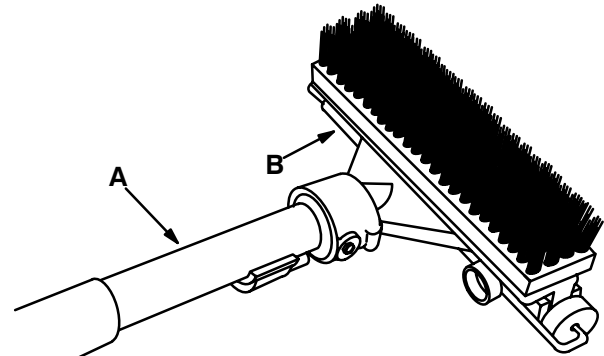

HARD FLOOR WAND

- A. Cleaning Tool
- B. Squeegee

If the hard floor wand is difficult to push or does not pick up the solution properly, adjust the roller wheels on the tool by turning the black adjustment knob.

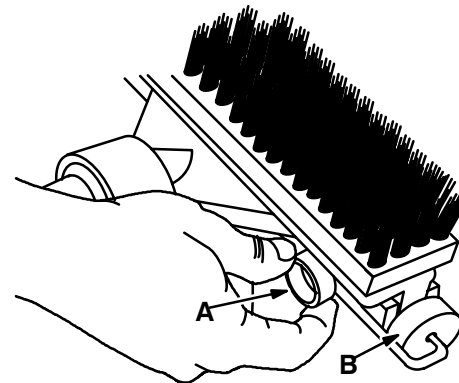

ADJUSTING ROLLER WHEELS

- A. Adjustment Knob
- B. Roller Wheels

The wheels are properly adjusted when the squeegee blades deflect slightly while the tool is pushed back and forth.

TROUBLE SHOOTING

PROBLEM	CAUSE	SOLUTION
Machine does not operate.	Power cord not plugged in	Plug into proper receptical
	Building circuit breaker tripped	Reset breaker
	Power cord/plug damaged	Repair or replace
	Electrical malfunction	Call Service Center
Vacuum motor does not operate when switch activated.	Worn motor brushes	Call Service Center
	Electrical malfunction	Call Service Center
Pump does not run; solution will not dispense to floor.	MODE switch is in wrong position	Move switch to proper position
	Solution tank is empty or low	Fill solution tank
	Quick-disconnect not connected	Connect properly
	Tank filter is plugged	Remove and clean filter
	Solution feed tube is plugged	Remove and clean tube
	Electrical or pump malfunction	Call Service Center
Brush does not run.	MODE switch is in wrong position	Move switch to proper position
	Circuit breaker is tripped	Reset breaker (reduce brush pressure)
	Drive belt broken	Call Service Center
	Electrical malfunction	Call Service Center
Brush circuit breaker trips.	Excessive brush pressure	Reduce brush pressure
	Electrical malfunction	Call Service Center
Brush does not clean floor.	Excessive soil may require several passes to clean	Double scrub area
	Brush worn	Replace brush
	Improper chemical for job	Select proper chemical
Solution feed will not shut off.	MODE switch in improper position	Move switch to proper position
	Pump malfunction	Call Service Center
Poor vacuum pickup or streaking.	Squeegee intake slots plugged	Clean
	Improper squeegee adjustment	Adjust
	Poor gasket seal on tank cover	Repair or replace
	Worn or damaged squeegee blades	Replace blades
Foam builds up in cover area and/or foam exits motor louvers.	Excessive or improper chemical used	Drain tank and refill with proper dilution
	Solution level too high	Reduce solution level below chain
	Air leak in cover gasket	Repair or replace

Motor Frame Group

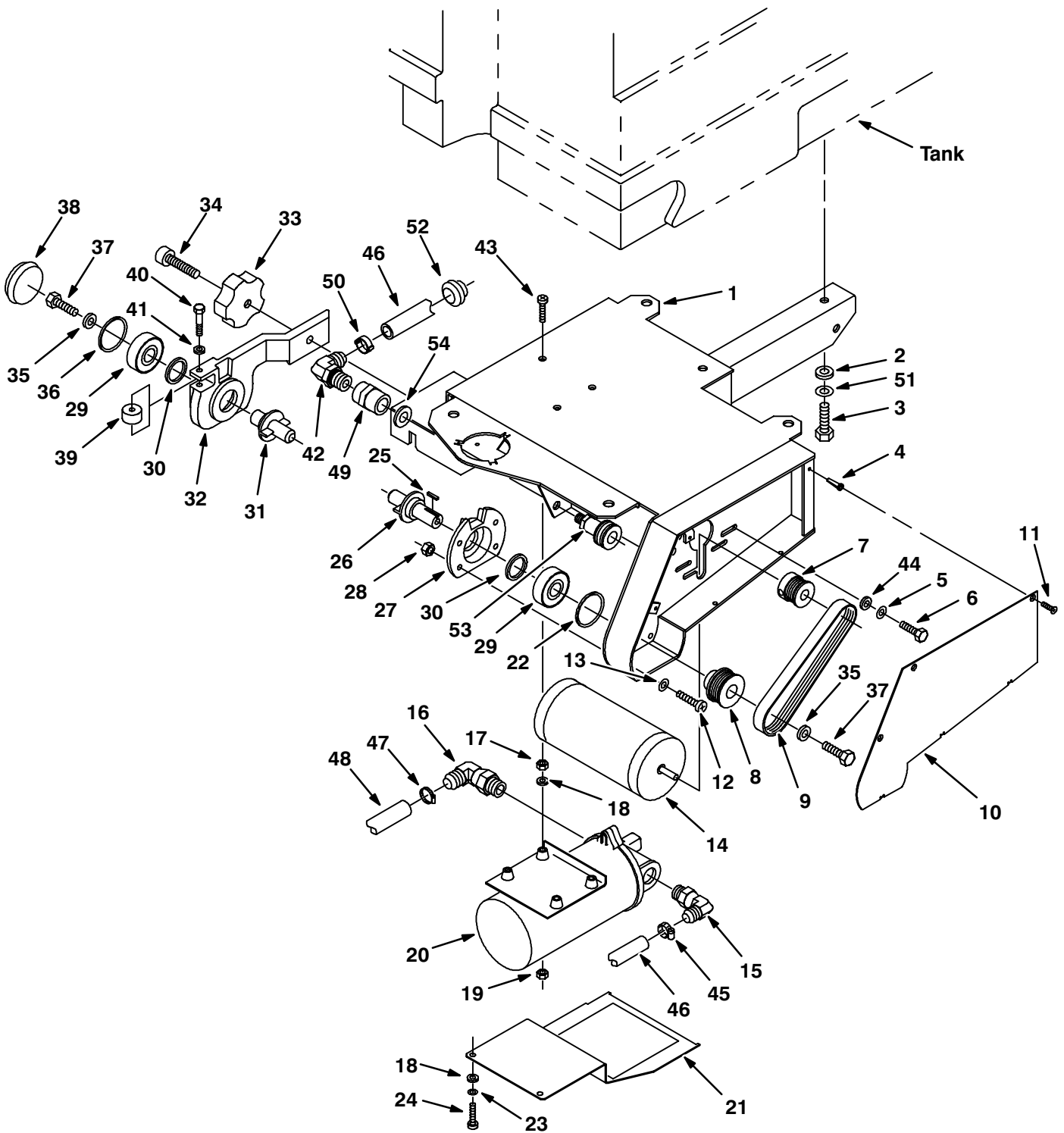

Motor Frame Group

REF	PART #	DESCRIPTION	QTY.
1	578-170-000	Frame, Motor	1
2	14880.5	Washer, Plain, Ansi-A .31" Wd, ZP	6
3	578237000	Screw, M8X1.25X18 HXHDCP	6
4	578-329-000	Screw Anchor #6	3
5	140016	Washer, Lock, SPG, Ansi, .25" ZP, 06	4
6	578-235-000	Screw, .25-20X.625	4
7	578414	Pulley, Motor	1
8	578413	Pulley, Brush	1
9	578-118-000	Belt, Length 381MM	1
10	578-182-000	Cover, Belt	1
11	578-278-000	Screw, 6-32 X .50"	3
12	578-187-000	Screw, M6.12MM	4
13	578-244-000	Washer, Lock, Int, 6.4 ID, 10MM,	4
14	578-028-000	Motor, Brush	1
15	578-040-000	Fitting, Elbow, 3/8NPT X .25 Hose	1
16	578-039-000	Fitting, Elbow, .50" Hose, .38"NPT	1
17	140288	Nut, Lock, M4,	3
18	578-186-000	Washer, Flat, 4.3 X 12 X 1.0	5
19	578-257-000	Nut, KEP, M4	3
20	578-331-000	Pump, 115 VAC	1
21	578-181-000	Cover, UL	1
22	578-319-000	O-Ring, 1.56"ID, 1.75"OD, Buna	1
23	140023	Washer, Internal Lock, #8	2
24	200-070-340	Screw, M4 X 8MM	2
25	578416	Key, Square, .125" X .125" X .50"	1
26	578597	Plug, Brush	1
27	578-163-000	Mount, Bearing	1
28	200-634-016	Nut, Hex, M6	4

REF	PART #	DESCRIPTION	QTY.
▽	578-801-000	ASM., Removable Brush Arm	1
▲29	140123	Bearing, Brush	2
▲30	578-138-000	Seal, Oil, Bearing, .94"ID, 1.31"OD	2
▲31	578-111-000	Plug, Brush, Idler	1
▲32	578577	Arm, Brush	1
▲33	578-156-000	Knob, Removable Arm	1
▲34	578-249-000	Screw, .38"-16 X 1.50"	1
▲35	578-261-000	Washer, Belleville, .31", .83"	2
▲36	578-102-000	Ring, Retaining, Internal	1
▲37	578717	Screw, M8 X 1.25 X 50MM	2
▲38	578-251-000	Cap, Bearing, Brush	1
▲39	578579	Spacer	1
▲40	578580	Screw, Hex Hd, M6 X 35	1
▲41	578728	Washer, Lock	1
42	150418	Fitting, Elbow, 1.25 Hose, 0.25"NPT	1
43	578-240-000	Screw, M4 X 30MM	3
44	579210	Washer, Flat, 6.4MM	4
45	140305	Clamp, Hose, 7/32-5/8	1
46	578-823-000	Hose, .25"ID	1
47	140310	Clamp, Hose, 5/16-7/8	1
48	578-822-000	Hose, .50"ID	1
49	150302	Fitting, 1/4F X 1/4F Coupling	1
50	578-161-000	Clamp, Hose, 8-11MM OD, Crimp	1
51	200-370-019	Washer, Lock, Int	8
52	578-304-000	Grommet, 13.2MM ID	1
53	575-520-000	Quick Connect, F 3/8" X 1/4"MPT	1
54	578-298-000	Washer, Flat, .64", .87", .031"	4

▽ Assembly

▲ Included in Assembly

Tank Group

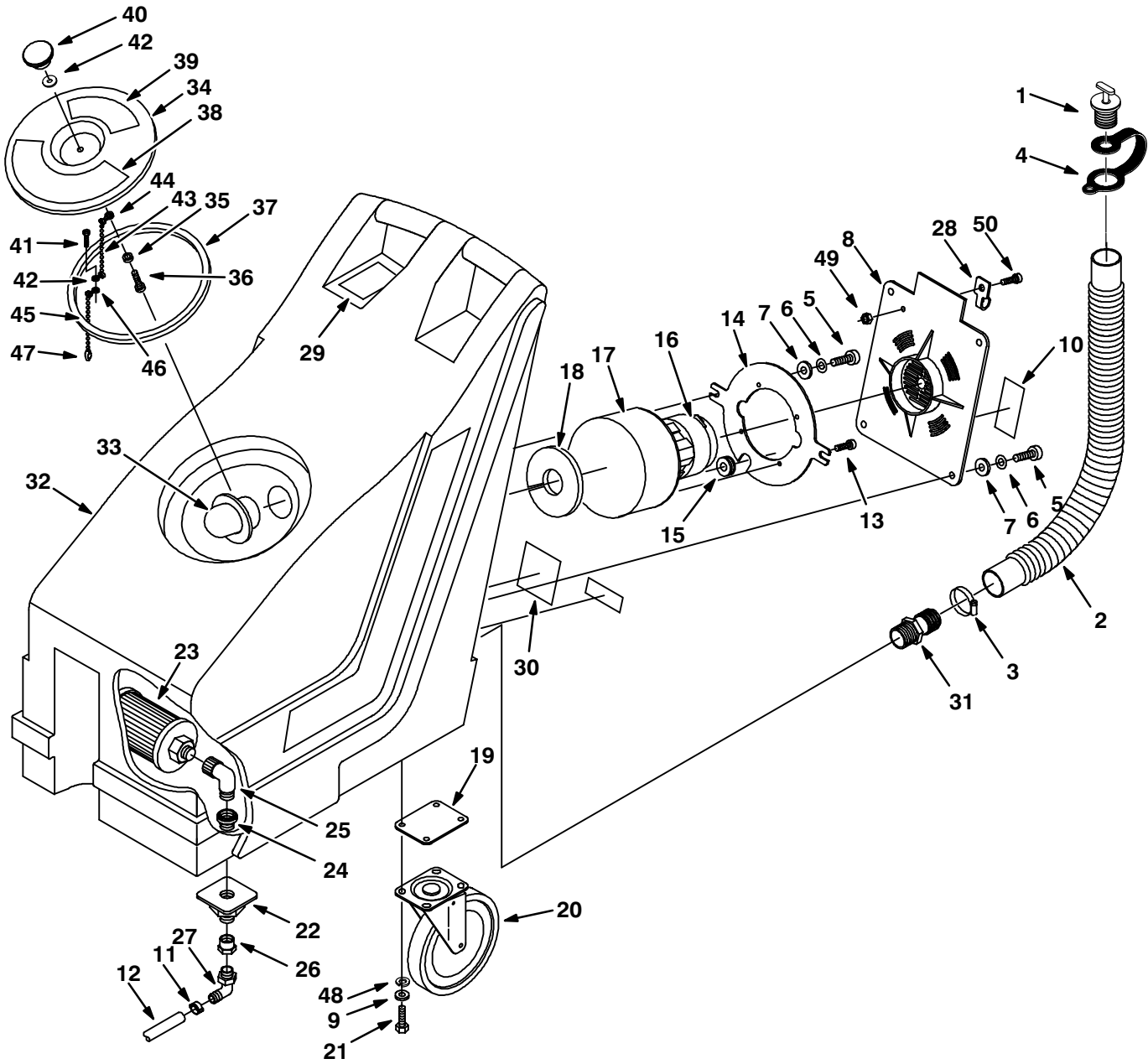

Tank Group

REF	PART #	DESCRIPTION	QTY.
▽	578-802-000	ASM., Drain Hose	1
▲1	621324	Plug, Expansion 1-5 Dia Nylon	1
▲2	578-031-000	Hose, Drain	1
▲3	140308	Clamp, Hose, 1.32-2.2	1
▲4	578441	Strap, Drain Hose	1
5	578-321-000	Screw, M6, 15MM	6
6	578-244-000	Washer, Lock, Int, 6.4MM	6
7	579-210-000	Washer, Flat, 6.4MM	6
8	578-018-000	Cover, Vac Motor	1
9	14880.5	Washer Plain, Ansi-1, 31" Wide, ZP	8
10	578768	Decal, Hazardous Voltage	1
11	578-162-000	Clamp, Crimp, 17-20MM OD Hose, SS	1
12	578-822-000	Hose, .50" ID	1
13	140340	Screw, #10 X 5/8"	4
14	578-016-000	Bracket, Vac Motor	1
15	578-009-000	Grommet, .50" ID, 0.81"GD, 0.12"GW	1
16	578417	Transition, Motor	1
17	630187	Motor, Vac, 115V, 60Hz	1
18	578424	Gasket, Foam, 102 OD, 38ID, 9.5	1
19	578-230-000	Shim, 95.0MM 70.0MM, 20Ga., ZP	2
20	578-012-000	Caster, 6"Dia.	2
21	578237000	Screw, Hex Hd, M8 X 18MM	8
22	621-139-000	Fitting Bulkhead 1 NPT	1
23	578-014-000	Filter, SRS, 100 Mesh	1
24	578-035-000	Fitting, Nipple, 1"NPT X Close	1
25	578-034-000	Fitting, Elbow, 1"NPT, Street	1
26	578-036-000	Fitting, Bushing, 1"MPT X 3/4"FPT	1
27	578-037-000	Fitting, Elbow, 0.50" Hose, 0.75"	1
28	575-520-000	Clip	1

REF	PART #	DESCRIPTION	QTY.
29	578729	Decal, Read Manual	1
30	578725	Decal, Brush Pressure Adjustment	1
31	621-277-000	Fitting, Straight, 1.5 Hose X 1.25NPT	1
32	608248	Tank, Recycle, Blue	1
33	578-020-000	Screen, Vacuum Fan	1
▽	578-590-000	ASM., Fill Cover	1
▲34	578-026-000	Cover Fill	1
▲35	25183.4	Washer, Sealing	1
▲36	578-299-000	Screw, 10-32 X .75" SS	1
▲37	578-303-000	Gasket	1
▲38	578767	Decal, Flammable Materials	1
▲39	578104	Decal, Filling Instructions	1
▲40	578301	Knob, Fill Cover, 10-32 F	1
▲▽	578-805-000	Ball Chain Assembly, Cover	1
▲41	578-142-000	Screw, #10, .50"	1
▲42	575601	Washer, Rubber	1
▲43	575537	Chain Ball #10	1
▲44	575536	End Coupling, Chain	2
▲▽	578-806-000	Ball Chain Assembly, Kit	1
▲45	575537	Chain Ball #10	1
▲46	575536	End Coupling, Chain	1
▲47	575-538-000	Spacing Link	1
48	200-370-019	Washer, Lock	8
49	140283	Nut, Lock, M5X.8	1
50	200-051-384	Screw, M5x14	1
N/S	120876	Decal, "Castex" Logo	1
N/S	608246	Decal, "GTC-170"	2

▽ Assembly

▲ Included in Assembly

Transport System

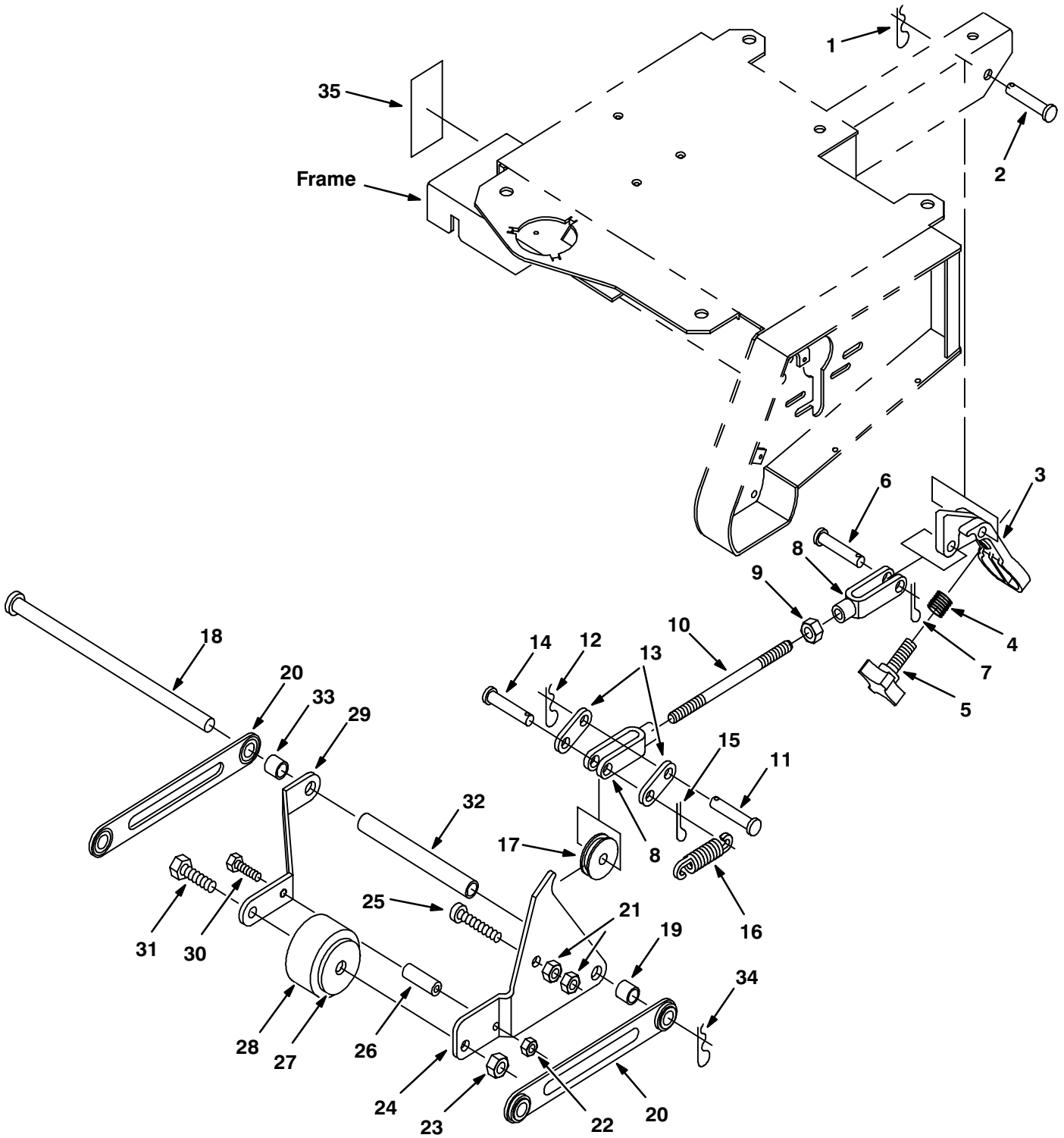

Transport System

REF	PART #	DESCRIPTION	QTY.
1	612-254-000	Pin, Hair Pin, 38"Dia Shaft	1
2	601-103-000	Pin, Clevis, .38 X 1.75" Lg.	1
3	578-135-000	Pedal, Transport	1
4	578-140-000	Spring, Compression, 1.00", 0.66", .049	1
5	578-139-000	Knob, Foot Pedal, Male	1
6	027-594-000	Pin, Clevis, .38"Dia. X 0.90"EFF, ZP	1
7	578420	Pin, Cotter, .09"Dia X .75 Lg.	1
8	578-085-000	Yoke, Adjustable, 3/8-24	2
9	578-242-000	Nut, Hex Jam, .38-24	1
10	578-132-000	Rod, Transport, 153MM, 3/8-24	1
11	578-202-000	Pin, Clevis, .38"Dia. X 1.50" Lg.	1
12	612-254-000	Pin, Hair Pin, 38"Dia Shaft	1
13	578-129-000	Transport Wheel Arm	2
14	578-231-000	Pin, Clevis, 38"Dia. X 2.00"Lg	1
15	578421	Pin, Cotter, 12"Dia. X 1.00"Lg	1
16	578-425	Spring, Extension, .63", 3.00, .63	1
17	578-130-000	Cam, Transport Wheel	1
18	578-220-000	Pin, Transport	1

REF	PART #	DESCRIPTION	QTY.
19	578-217-000	Spacer, 12.7MM ID X 21.3 OD X 14.7MM	1
20	578-104-000	Arm, Brush Wrap	2
21	140288	Nut, Lock, M4	2
22	140284	Nut, Hex Lock, M6	1
23	140515	Nut, Hex Lock	1
24	578-136-000	Left Arm, Transport	1
25	578-243-000	Screw, M4 X 20	1
26	578-137-000	Spacer, 6.4 ID X 12.7 OD X 39.7 Lg., ZP	1
27	578-116-000	Guard, Thread Wheel	2
28	578-115-000	Wheel, Transport	1
29	578-128-000	Right Arm, Transport	1
30	578-208-000	Screw, M6 X 55	1
31	578-206-000	Screw, .38-16, 2.50"	1
32	578-219-000	Spacer, 12.7 ID, 21.3OD, 140MM Lg	1
33	578-218-000	Spacer, 12.7MM ID, 21.3MM X 8.6MM Lg	1
34	140626	Pin, Hitch	1
35	578769	Decal, Moving Parts	1

Squeegee Head Group

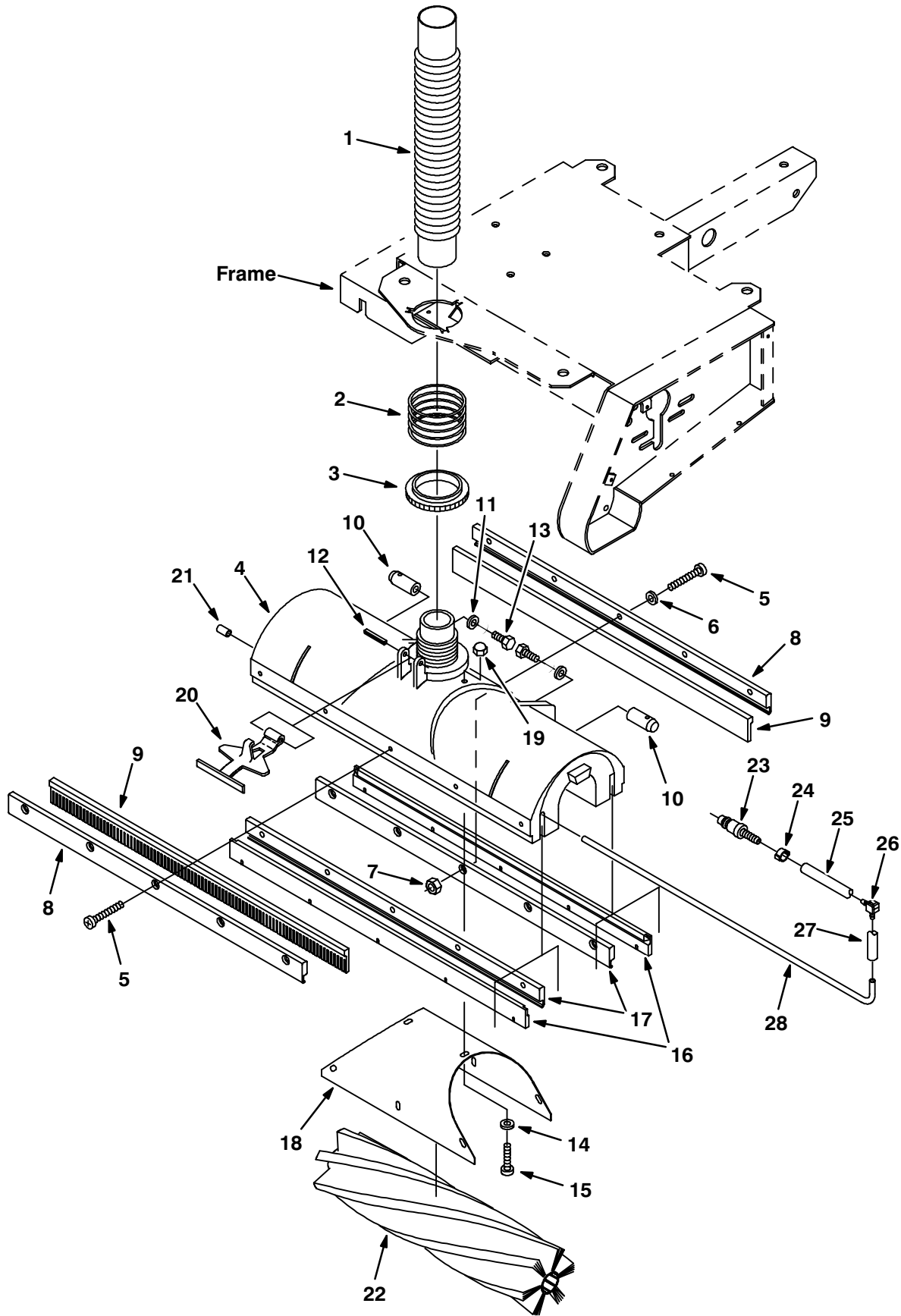

Squeegee Head Group

REF	PART #	DESCRIPTION	QTY.
1	578-021-000	Hose, Recovery, Dia. 38.1	1
2	578-127-000	Spring, Down Pressure Head 2.5"	1
3	578-122-000	Nut, Knurl	1
∇	578-803-000	ASM.,Scrubber Head	1
▲4	578-101-000	Head, Scrubber	1
▲5	578-193-000	Screw, M4 X 25	10
▲6	140023	Washer, Lock, Int.	10
▲7	200-633-014	Nut, Hex, M4	10
▲8	578592	Squeegee Blade Retainer, inner, black	2
▲9	578-106-000	Squeegee Blade Outer	2
▲10	578-216-000	Pin, Scrub Head, SS	2
▲11	200-370-019	Washer, Internal Lock	2
▲12	579059	Pin, Spring Lock	1
▲13	578-237-000	Screw, M8 X 18	2
▲14	578-195-000	Washer, Flat	2

REF	PART #	DESCRIPTION	QTY.
▲15	579237	Screw, M4 X 10,	2
▲16	578-107-000	Squeegee Blade Inner	2
▲17	578591	Squeegee Blade Retainer, outer, tan	2
▲18	578-119-000	Inner Brush Wrap	1
▲19	140288	Nut, Lock, M4	2
▲20	579100	Latch, Double Scrub	1
21	578723	Cap, Manifold End, 5.8MM ID	1
22	578-112-000	Brush, Cylindrical 17", Nylon	1
23	578-318-000	Fitting, QConn, Male, 3/8", 1/4" H	1
24	578-161-000	Clamp, Hose, 8-11MM OD, Crimp	1
25	578-095-000	Hose, .25" ID	.115M
26	578437	Valve, Check, 1/4" X 1/4" Barb, 3 PSI	1
27	578-095-000	Hose, .25" ID	.030M
28	578-055-000	Manifold, Tube	1

∇ Assembly

▲ Included in Assembly

Electrical Panel

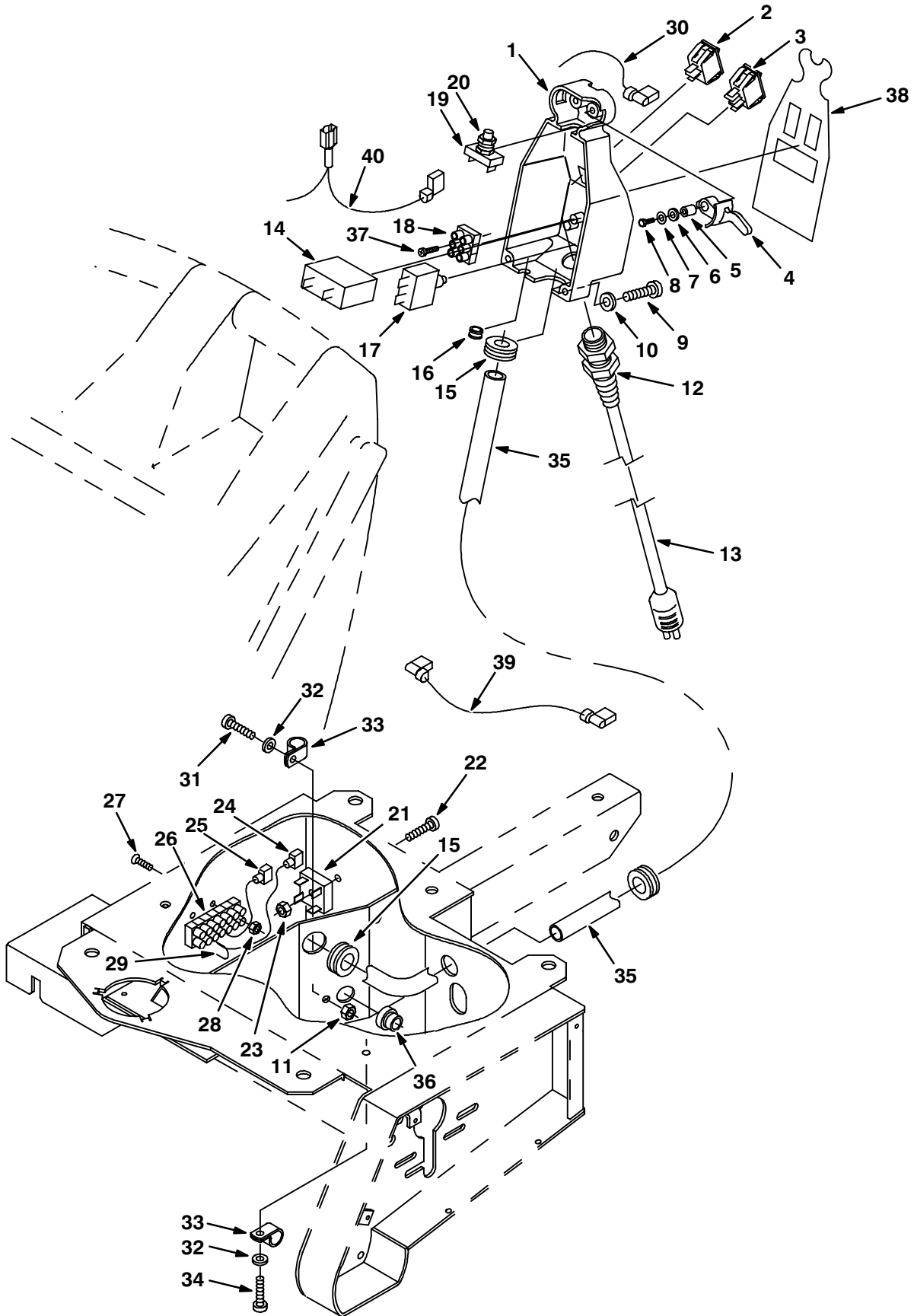

Electrical Panel

REF	PART #	DESCRIPTION	QTY.
1	578-001-000	Cover, Console	1
2	578-005-000	Switch, Rocker SPST	1
3	578-272-000	Switch, Rocker, SPDT	1
4	578-002-000	Arm, Trigger	2
5	578-082-000	Spacer, Trigger	2
6	578-186-000	Washer, Flat	2
7	200-662-012	Washer, Lock, Int	2
8	069-764-190	Screw, M3 X 16	2
9	578-008-000	Screw, 5 X 31.3	3
10	140018	Washer, Lock, Int.	3
11	140288	Nut, Lock, M4	1
12	130167	Strain Relief Cord, Pigtail	1
13	578-023-000	Cord Set, 14/3SJT, Yellow, 40' Lg	1
14	578595	Gauge, Brush Pressure	1
15	578-009-000	Grommet, .50" ID, 0.81GD, .12"GW	3
16	578-080-000	Grommet, .18" ID, .31"GD, .12"GW	1
17	578-004-000	Circuit Breaker, 3AMP	1
18	578-007-000	Terminal Block 3 Position	1
19	130712	Switch, Momentary Pulse	1
20	578-430	Washer, Bevel	1

REF	PART #	DESCRIPTION	QTY.
21	130780	Rectifier, Full Wave, 100V, 10A	1
22	578-302-000	Screw, M5 x 20MM	1
23	140283	Nut, Lock, M5	1
24	578-252-000	Wire, Jumper, White	1
25	578-255-000	Wire, Jumper, Black	1
26	578-013-000	Terminal Block, 7 Pos.	1
27	200-631-266	Screw, M3 X 16MM	2
28	579211	Nut, Lock, M3	2
29	578-259-000	Wire, Jumper, Green	1
30	578-029-000	Wire Assy, 16 Ga, 120MM, black	1
31	578259	Screw, M4 X 12MM	1
32	578-195-000	Washer, Flat	2
33	578-256-000	Clamp, Cable, .44"ID	2
34	200-070-340	Screw, M4 X 8MM	1
35	578-058-000	Wire Harness	1
36	578-324-000	Strain Relief, Motor Leads	1
37	578-011-000	Screw, #6	2
38	578779	Decal, "Console"	1
39	578-075-000	Wire Assy, 16 Ga, 90MM, white	1
40	578-260-000	Wire Assy, 16 Ga, black	1

Pump Motor

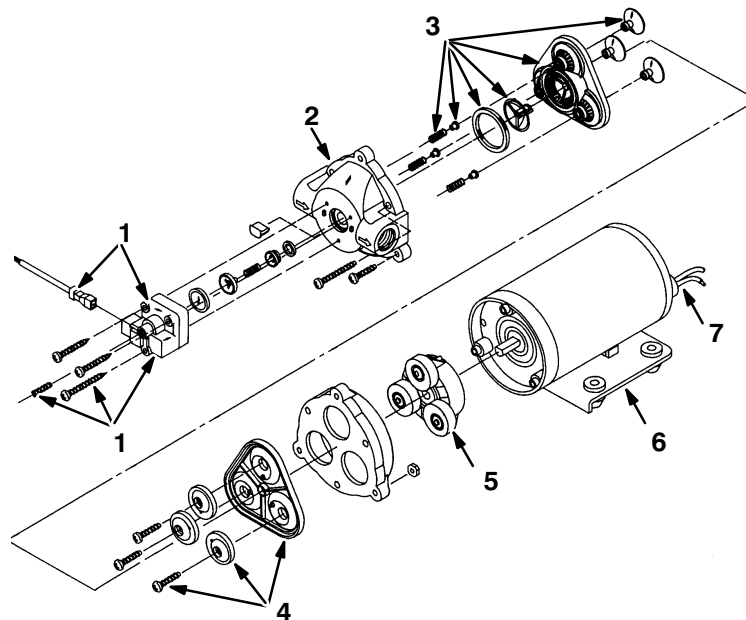

REF	PART #	DESCRIPTION	QTY.
▽	578-331-000	ASM., Pump Motor	1
▲▽	578-807-000	ASM., Pump Head	1
▲1	578-812-000	Switch, Pressure	1
▲2	578-813-000	Upper Housing	1
▲3	578-811-000	Valves (Buna-N) 60 PSI Bypass	1

REF	PART #	DESCRIPTION	QTY.
▲4	578-810-000	Diaphragm (Geolast)	1
▲5	578-809-000	Drive Assembly - 2.0 CAM	1
▲▽6	578-808-000	115 VAC Motor W/Rect.	1
▲7	578-440	Brushes	2
▲8	578-814-000	Rectifier	1

- ▽ Assembly
- ▲ Included in Assembly

PARTS LIST

Vacuum Motor

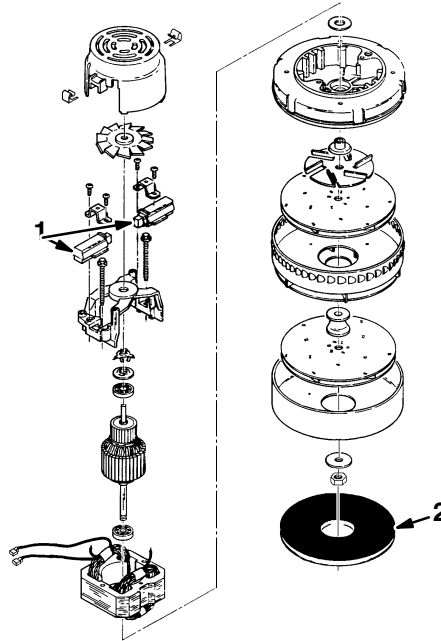

REF	PART #	DESCRIPTION	QTY.
▽	578-328-000	ASM., Vacuum Fan	1
▲1	578-429-000	Brush, Vac Fan Motor	2

REF	PART #	DESCRIPTION	QTY.
▲2	578-424-000	Gasket, Foam, 102OD, 38ID, 9.5	1

- ▽ Assembly
- ▲ Included in Assembly

Brush Motor

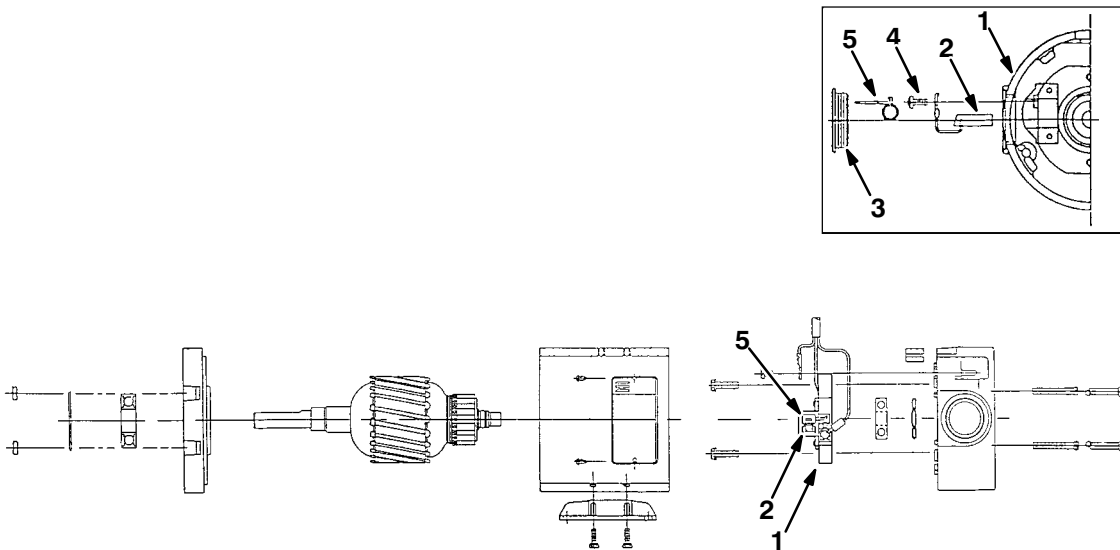

REF	PART #	DESCRIPTION	QTY.
▽	578028000	ASM., Brush Motor	1
▲1	578885	Brush Insulator	1
▲2	578886	Brush Assembly	1

REF	PART #	DESCRIPTION	QTY.
▲3	578887	Cap	2
▲4	578888	Screw	1
▲5	578889	Spring	1

- ▽ Assembly
- ▲ Included in Assembly

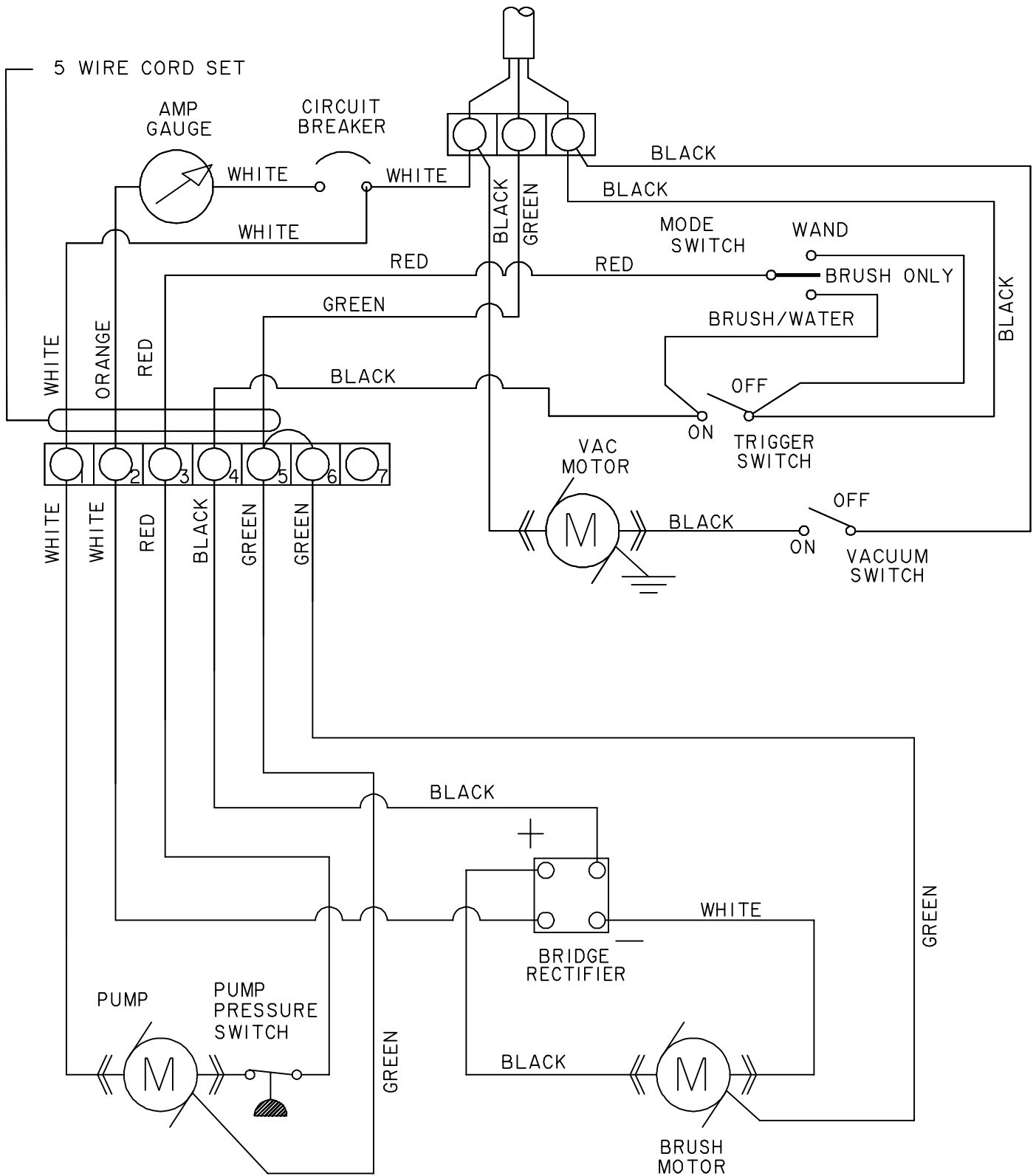

Hard Floor Wand

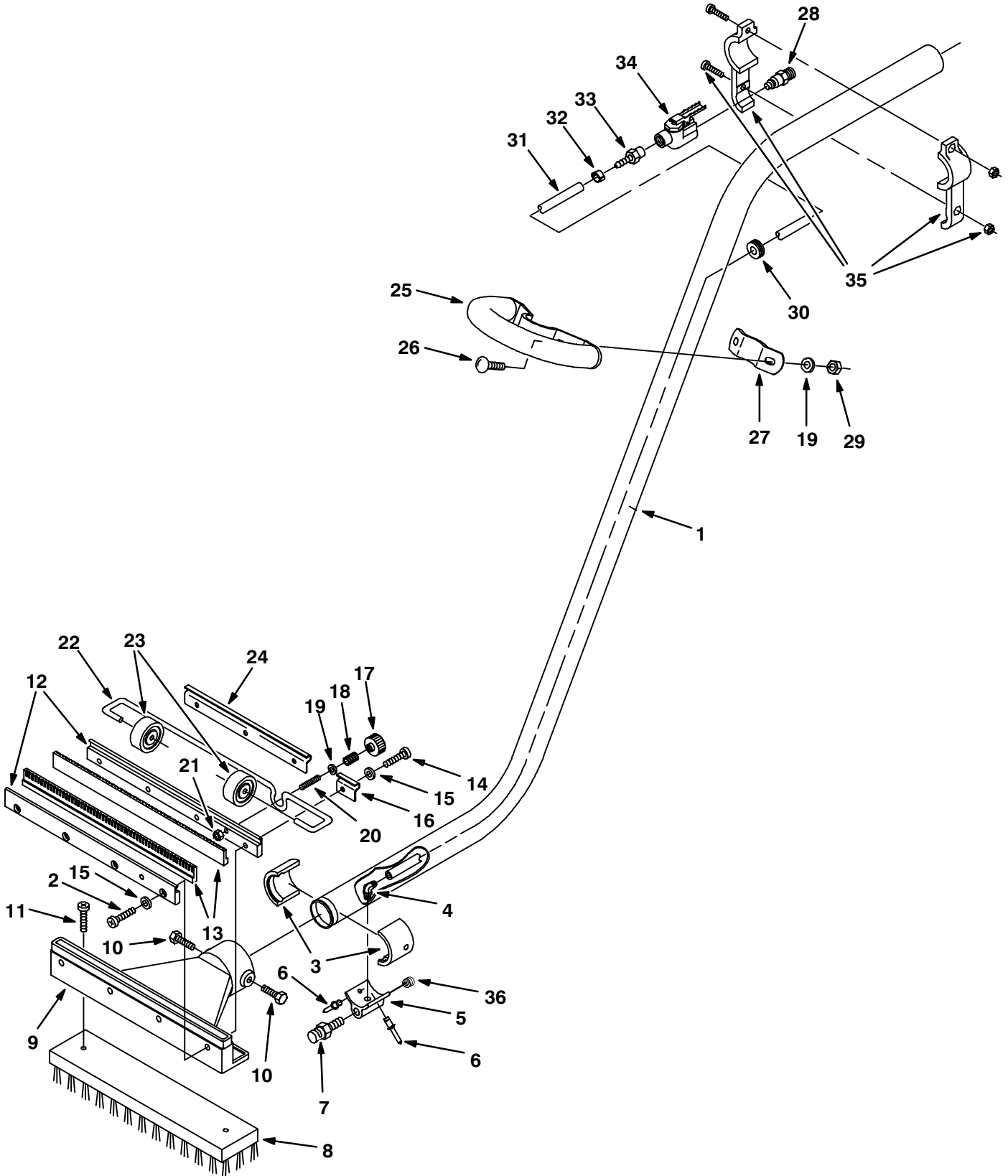

Hard Floor Wand

REF	PART #	DESCRIPTION	QTY.
▽	578-905-000	ASM.,Wand, Double Bend, Dia 38.1MM	1
▲1	578-060-000	Wand, Double Bend, Dia 38.1MM	1
▲2	578-144-000	Screw, Pan Hd., Phil, M5 X 16MM Lg., SS	4
▲3	578-061-000	Adapter, Head/Wand	2
▲4	578-214-000	Fitting, Elbow, 0.25"Hose, 0.12"NPT	1
▲5	579112	Adapter,Spray Nozzle	1
▲6	579198	Rivet, Pop, S-2500 Driveblock	2
▲7	578-066-000	Spray Nozzle, .125" NPT, 75 Deg.	1
▲8	578-073-000	Brush, Wand Attachment	1
▲9	578-063-000	Head, Wand	1
▲10	140885	Screw, 1/4-20X1/2 TRSPHL	2
▲11	621-366-000	Screw, S-Tap #10-16 X 3/4"Philips	2
▲12	578-078-000	Retainer, Squeegee Wand	2
▲13	578-074-000	Blade, Squeegee Wand	2
▲14	578-141-000	Screw, Pan Hd., Phil, M5 X 10MM Lg., SS	4
▲15	140018	Washer, #10 INT	8
▲16	578-124-000	Bracket, Axle, 1-Hole	1
▲17	578-439-000	Nut, Thumb, MO6 X Dia 30MM	1
▲18	578-228-000	Spring, Compression, .63", .42", .04	1

REF	PART #	DESCRIPTION	QTY.
▲19	200-304-017	Washer, Flat, 6.4MM, 13.0, 1.6	3
▲20	578-143-000	M6, 40mm Lg., Adjust. Stud	1
▲21	200-634-016	Hex Nut, M6	1
▲22	578-126-000	Axle, Wand	1
▲23	578-125-000	Wheel, Guide, Wand	2
▲24	578-123-000	Bracket, Axle, 3-Hole	1
▲25	578-155-000	Handle, Wand	1
▲26	578-211-000	Screw, Car, .25-20unc, .75", ZP	2
▲27	578-154-000	Bracket, Handle, Wand	1
▲28	578-091-000	Male Quick-Conn., 1/4"NPT	1
▲29	578-323-000	Nut, Hex Lock, .25-20UNC, Nyl. INS	2
▲30	578-164-000	Grommet, .38"ID. .63"OD, .06"OW	1
▲31	578-821-000	Hose, Solution, Wand	1
▲32	578-161-000	Clamp, Hose, 8-11MM OD, Crimp	1
▲33	578-094-000	1/4 Hosebarb, 3/8NPT Male Pipe	1
▲34	578-064-000	Valve, Water Control, Wand	1
▲35	578-077-000	Bracket, Valve Mounting, Wand	1
▲36	150208	Fitting, Plug	1

▽ Assembly

▲ Included in Assembly

Detergents

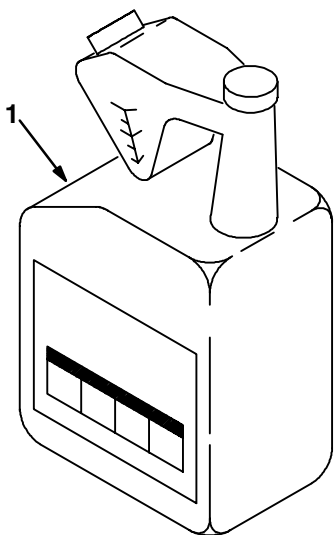

REF	PART #	DESCRIPTION	QTY.
1	579167	CHEMICAL, 830, GREASE & ANIIMAL FATS	4X1GAL
	579166	CHEMICAL, 820, GENERAL CLEANING	4X1GAL

OPTIONS

Hose Assembly

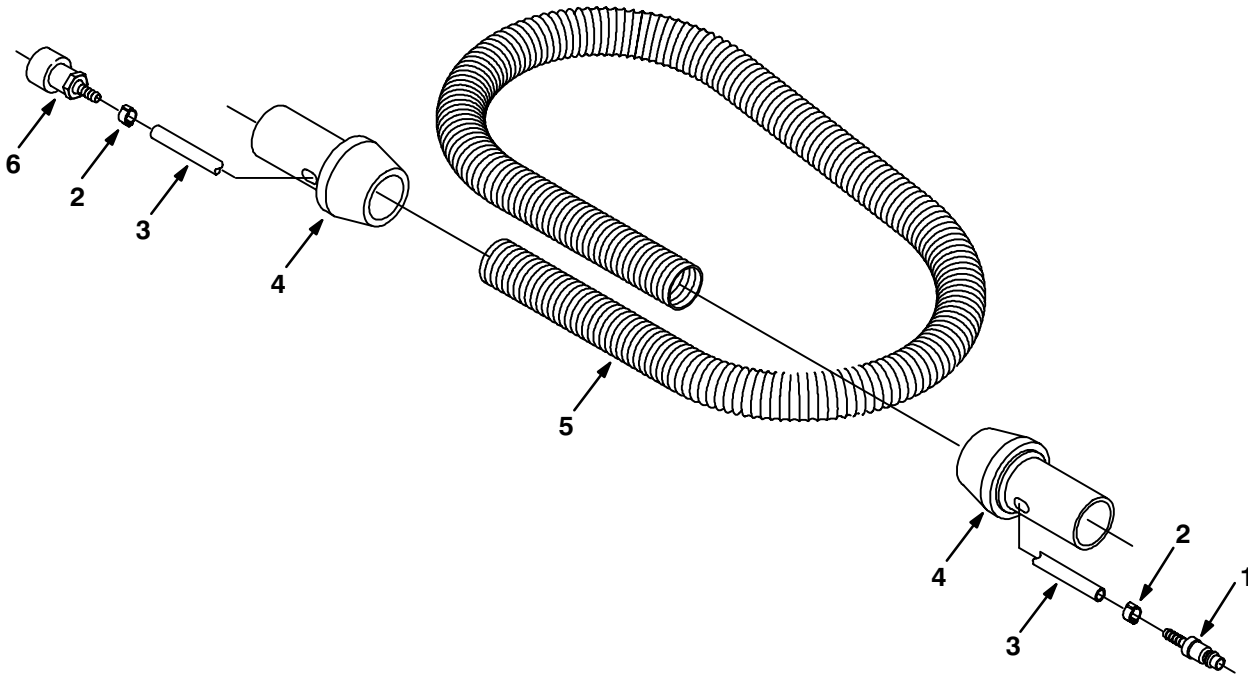

REF	PART #	DESCRIPTION	QTY.
▽	578-903-000	ASM., Hose	1
▲1	578-318-000	Fitting, Quick Conn, Male, .375", 1/4"H	1
▲2	578-160-000	Clamp, Hose, 11-13MM OD, Crimp, SS	2
▲3	578-820-000	Hose	1
▲4	578-072-000	Cuff, Swivel, 38.1 Dia., Black	2

REF	PART #	DESCRIPTION	QTY.
▲5	578-276-000	Hose, Vac, Dia 38.1 X 3.05M, Grey	1
▲6	578-071-000	Quick Conn, Female, 1/4" X 1/4"H	1
▲NS	231031	Sleeve, 1 1/2 X 5"	1

- ▽ Assembly
- ▲ Included in Assembly

Upholstery Tool

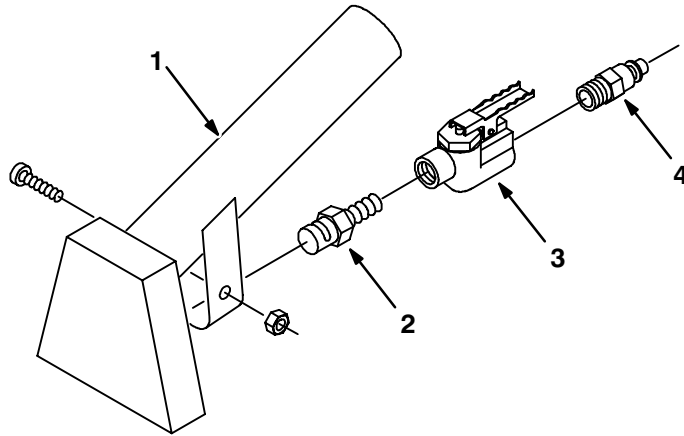

REF	PART #	DESCRIPTION	QTY.
▽1	575-584	ASM., Upholstery Tool	1
▲2	575-519-000	Nozzle	1
▲3	578-064-000	Valve, Water Control	1
▲4	578-091-000	Plug, Quick Connect, 1/4"MPT	1

- ▽ Assembly
- ▲ Included in Assembly