

Castex®

Viper™

Upright Vacuum Cleaner

Model No.: 604900 – 120V

Operator and Parts Manual

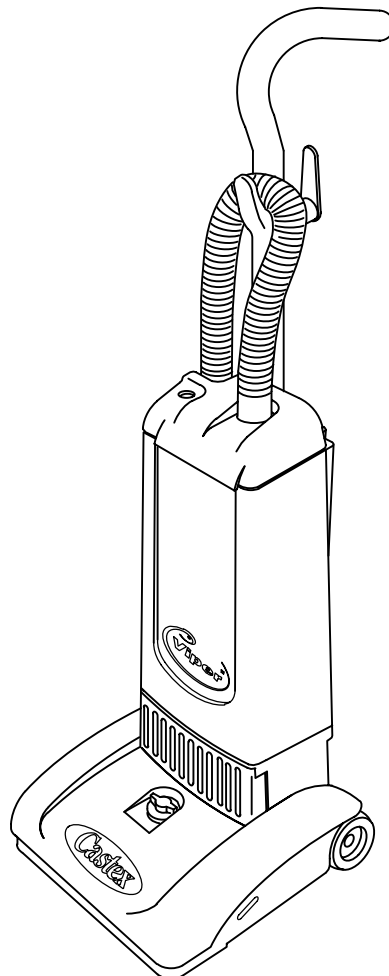

CASTEX INCORPORATED
12875 RANSOM STREET
HOLLAND MI 49424 U.S.A.

A TENNANT COMPANY

1-800-522-7839
616-786-2330
FAX: 1-800-678-4240
CUSTOMER SERVICE: 1-800-964-9644

605012
Rev. 01 (03-99)

BAG HOUSING GROUP

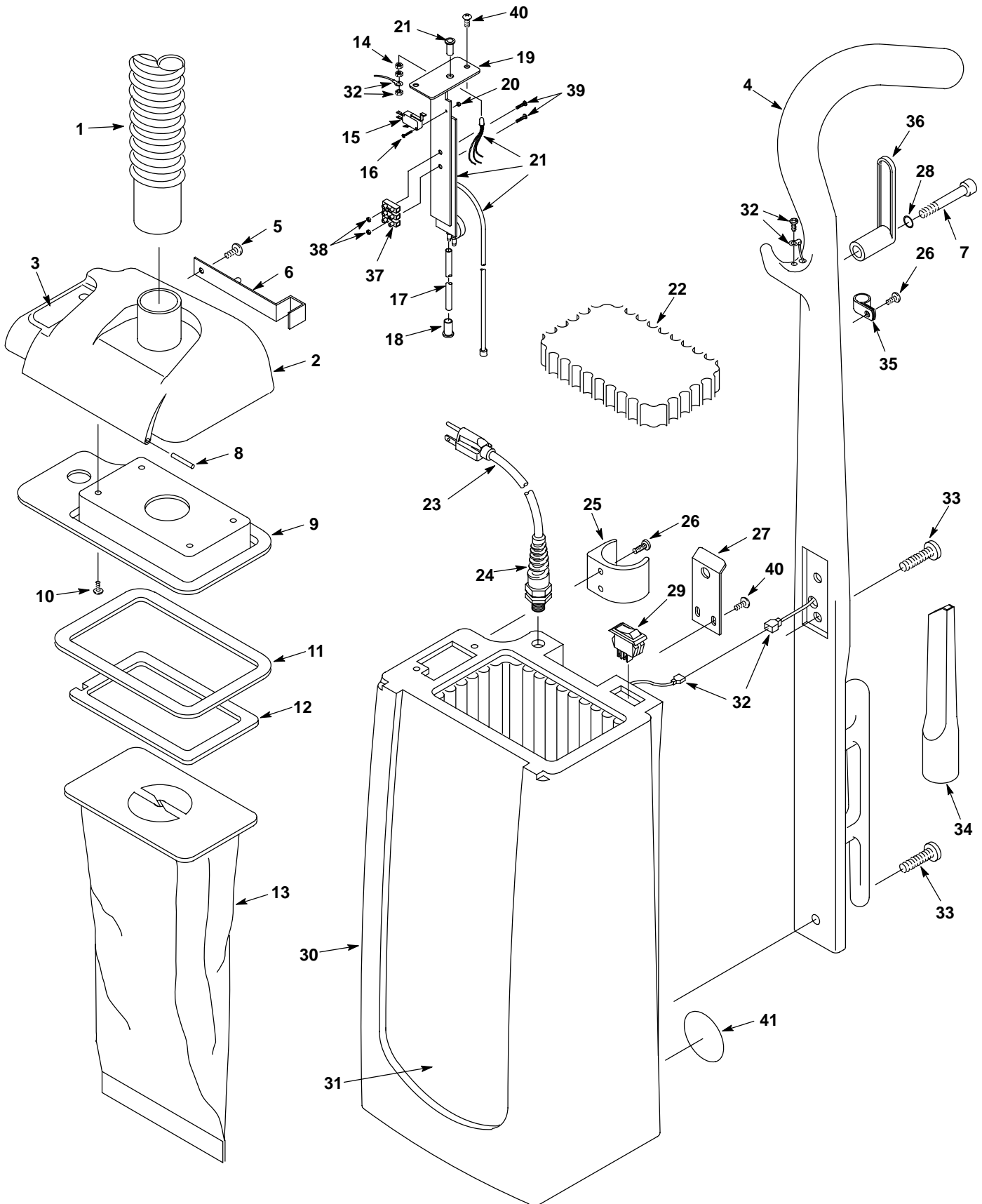

BAG HOUSING GROUP

REF	PART #	DESCRIPTION	QTY.
1	605011	●ASM., VAC HOSE WAND (see pg. 12)	1
2	604837	LID, BAG HOUSING, GRAY	1
3	605998	DECAL, INDICATOR LIGHT	1
4	606603	HANDLE, GRAY	1
5	604930	SCREW, M5X.8X10	1
6	605016	LATCH, LID	1
7	200017494	SCREW, M8X30	1
8	603114	DOWEL, 1/8 DIA X 1-1/4"	2
9	604836	PLATE, BOTTOM LID	1
10	140825	SCREW, #6X1/2	4
11	604834	●GASKET, LID OUTER	1
12	604833	●GASKET, LID INNER	1
13	604838	●BAG, PAPER (100 CASE)	1
14	140297	NUT, M5X.8 HEXLOCK	2
15	604839	●SWITCH, SNAP ACTION ON/OFF	1
16	200070266	SCREW, M3X.5X16	2
17	606357	HOSE, 1/8ID X 1/4OD, 18"	1
18	605984	BUSHING, BAG-FULL-HOSE	1
19	604835	BRACKET, SWITCH/LIGHT	1
20	579211	NUT, M3X.5 HEX	2
21	605994	●CONTROL BOARD (120 VOLT)	1
	605995	●CONTROL BOARD (230V/240V)	1
22	604832	●FILTER, VAC MOTOR (SECONDARY)	1
23	604842	●CORD, 18/3 X 40' GRAY (120 VOLT)	1
	600398	●CORD, 3 X 1 x 12M (230V/240V)	1

REF	PART #	DESCRIPTION	QTY.
24	130166	●CORD GRIP, NYLON/BLK W/NUT	1
25	604847	●CLIP, WAND	1
26	607006	SCREW, M4X.7X12	3
27	604844	STRIKE, LID LATCH	1
28	204001009	●O-RING, 7.66MM ID X 1.78MM WIDE	1
29	039708037	●SWITCH, ROCKER ON/OFF (120 VOLT)	1
	602669	●SWITCH, ROCKER ON/OFF (230V/240V)	1
30	606602	HOUSING, BAG, GRAY	1
31	605013	DECAL, VIPER LOGO	1
▽32	607286	KIT, ANTI-STATIC WIRING	1
▲	130130	TERMINAL, RING #10	1
▲	140297	NUT, M5X.8 HEX SS	1
▲	607284	ASM., WIRE #18X18GRN 1/4F	1
▲	130133	TERMINAL, 1/4M	1
▲	607285	ASM., WIRE #18X18GRN #6 RING	1
▲	140825	SCREW, #6X1/2	1
33	605557	SCREW, M6X1X30	2
34	604804	●TOOL, CREVICE 35MM (1.38")	1
35	579223	●CLAMP, CORD	1
36	604846	●HOOK, CORD QUICK-RELEASE	1
37	130005	STRIP, TERMINAL 25 AMP (230V/240V ONLY)	1
38	140534	NUT, 6-32 (230V/240V ONLY)	2
39	140879	SCREW, 6-32X3/4 (230V/240V ONLY)	2
40	606694	SCREW, M4X.7X8	4
41	120099	DECAL, PREVENTIVE (CASTEX ONLY)	1

▽ ASSEMBLY

▲ INCLUDED IN ASSEMBLY

● RECOMMENDED STOCK ITEMS

PARTS LIST

VACUUM MOTOR HOUSING GROUP

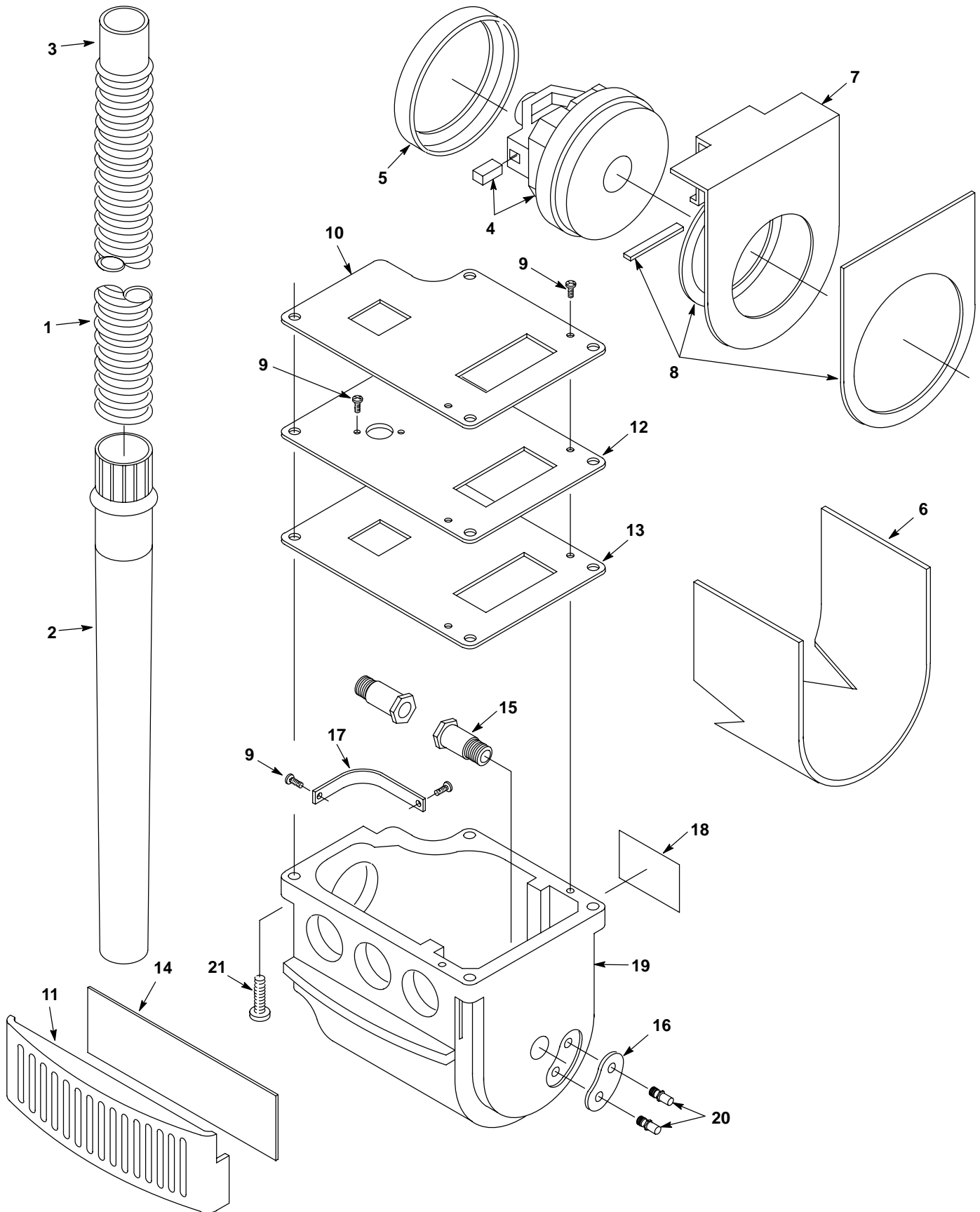

VACUUM MOTOR HOUSING GROUP

REF	PART #	DESCRIPTION	QTY.
▽	605011	●ASM., VAC HOSE WAND	1
▲1	604840	HOSE, VAC WAND 1-1/4 ID	1
▲2	604841	WAND, 35MM ID X 19 LG SWIVEL	1
▲3	604929	CUFF, 1-1/4"	1
4	604815	●MOTOR, VAC 5.1" 120V	1
	605996	●MOTOR, VAC 5.1" 230V/240V	1
	606382	●CARBON BRUSH 120V (2 pack)	2
	606417	●CARBON BRUSH 230V/240V (2 pack)	2
5	604816	GASKET, VAC MOTOR	1
6	604822	FOAM, NOISE 1/4X14-1/4X5	1
7	604826	INLET PLATE, VAC MOTOR	1
8	605080	GASKET, INLET PLATE	1
9	607006	SCREW, M4X.7X12	6
10	606732	GASKET, UPPER CLAMP PLATE	1
11	606728	COVER, EXHAUST FILTER, GRAY	1

REF	PART #	DESCRIPTION	QTY.
12	606730	CLAMP PLATE, VAC MOTOR	1
13	606731	GASKET, LOWER CLAMP PLATE	1
14	606982	●FILTER, EXHAUST (3 PACK)	1
15	604813	SCREW, SHOULDER PIVOT	2
16	606723	PLATE, FOOT LATCH	1
17	604830	STRAP, WAND CUFF	1
18	602595	DECAL, WARNING VACUUM CSA	1
19	606601	HOUSING, VACUUM MOTOR, GRAY	1
20	604827	STUD, FOOT-LATCH	2
21	605557	SCREW, M6X1.0X30	4
N/S	605981	HARNESS, LOWER WIRE	1

▽ ASSEMBLY

▲ INCLUDED IN ASSEMBLY

● RECOMMENDED STOCK ITEMS

BRUSH BASE GROUP

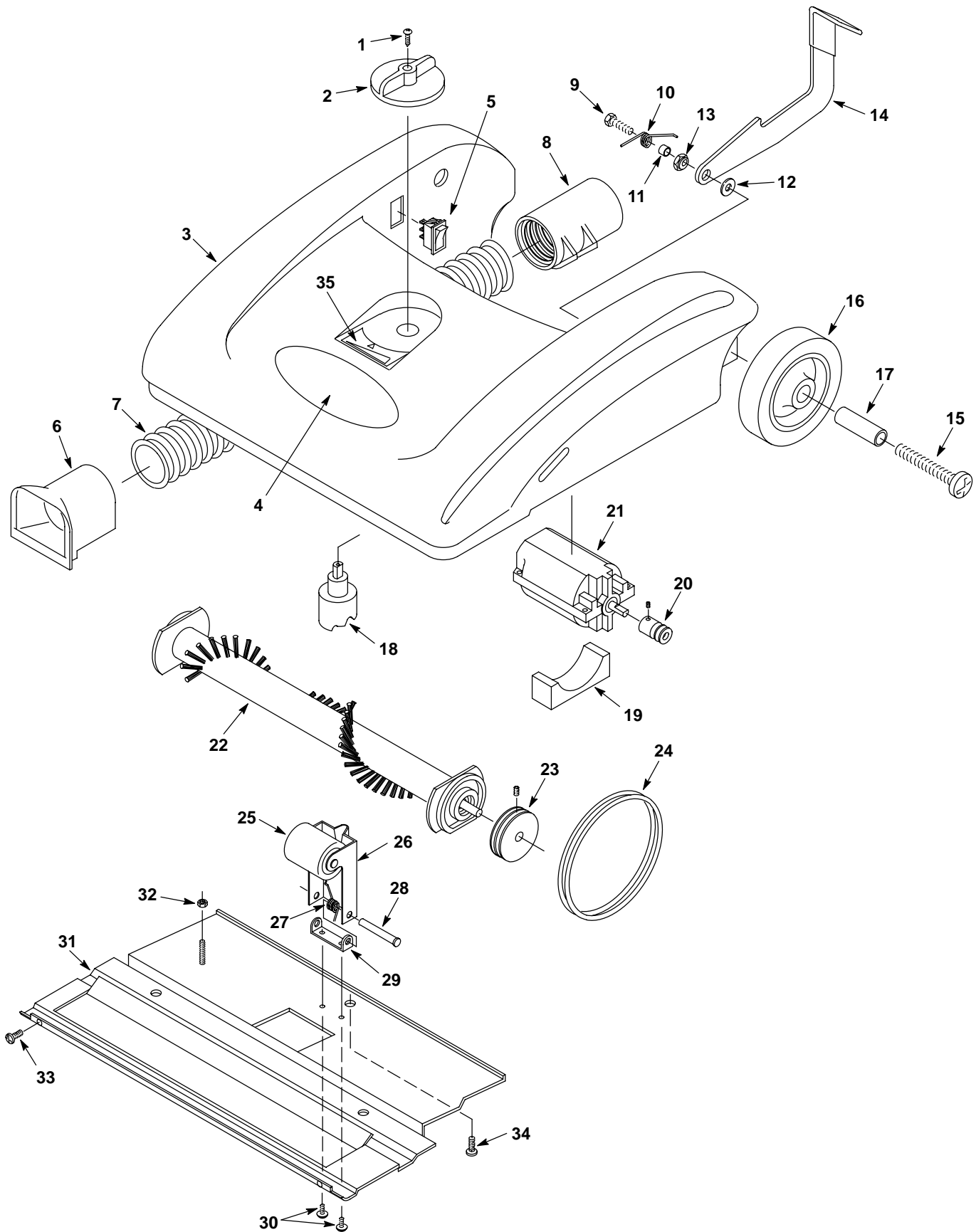

BRUSH BASE GROUP

REF	PART #	DESCRIPTION	QTY.
1	140825	SCREW, #6X1/2	1
2	604811	KNOB, HT. ADJUSTMENT	1
3	606600	BASE, BLUE	1
4	120101	DECAL, "CASTEX"	1
5	039708037	●SWITCH, ON/OFF ROCKER	1
▽	605010	●ASM., VAC HOSE	1
▲6	604805	CUFF, BASE INLET	1
▲7	604806	HOSE FLEX 1-1/4 ID	1
▲8	604829	CUFF, WAND	1
9	200031444	SCREW, M6X1.0X30	1
10	604828	SPRING, TORSION FOOT-LATCH	1
11	140154	SPACER, .25X.38X.31	1
12	579210	WASHER, 6.4X18.0X1.5 FLAT	1
13	605078	BUSHING, FOOT-LATCH ADJUSTMENT	1
14	604808	LATCH, FOOT BASE	1
15	606983	SCREW, M8X1.25X40	2
▽16	630450	●WHEEL, 76 DIA X 22 WD RUBBER	2
▲17	103070	BUSHING, WHEEL	2
18	230754	●CAM, HEIGHT ADJUSTER	1
19	604812	GASKET, FOAM BRUSH MTR	1

REF	PART #	DESCRIPTION	QTY.
20	230347	PULLEY, MOTOR (DOUBLE "V")	1
21	130398	●MOTOR, BRUSH DRIVE 120 VOLT	1
	130399	●MOTOR, BRUSH DRIVE 230V/240V	1
22	604803	●BRUSH ASM.	1
23	230348	PULLEY, BRUSH (DOUBLE "V")	1
24	230349	●BELT, BRUSH DRIVE	2
▽	501086	●ASM., BASE ROLLER & BRACKET	1
▲25	26548	ROLLER, BASE HOUSING FRONT	1
▲26	230753	BRACKET, ROLLER	1
▲27	140436	SPRING, TORSION HT ADJUSTMENT	1
▲28	140710	RIVET, AXLE 3/8 X 1.6	2
▲29	230769	BRACKET, ROLLER PIVOT	1
30	140264	SCREW, 8-32X1/4	2
31	606733	SHOE, BASE 14"	1
32	140297	NUT, M5X.8 HEX	1
33	606694	SCREW, M4X.7X8	2
34	607006	SCREW, M4X.7X12	3
35	606691	DECAL, HEIGHT ADJUSTMENT	1

▽ ASSEMBLY

▲ INCLUDED IN ASSEMBLY

● RECOMMENDED STOCK ITEMS

OPTIONAL ATTACHMENT KIT

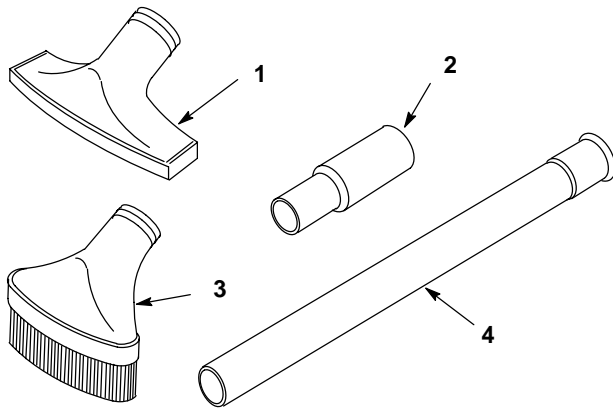

REF	PART #	DESCRIPTION	QTY.
▽	604802	●KIT, ATTACHMENT	1
▲1	609194	UPHOLSTERY TOOL	1
▲2	609196	ADAPTOR	1
▲3	609193	DUSTING BRUSH	1
▲4	609195	EXTENSION WAND	1

REPLACEMENT BAGS

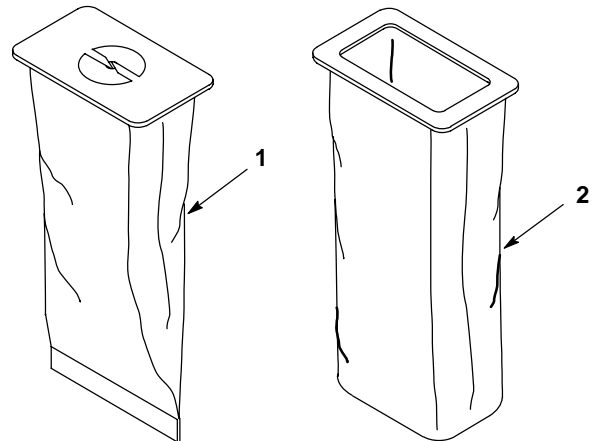

REF	PART #	DESCRIPTION	QTY.
1	604838	●BAG, PAPER (CASE OF 100)	1
2	900034	●BAG, CLOTH	1

WIRE DIAGRAM

