

Castex®

WD85-15/10/05

Wet/Dry Vacuum

Model No.:

610118 – WD85-15

610119 – WD85-10

610120 – WD85-05

Operator and Parts Manual

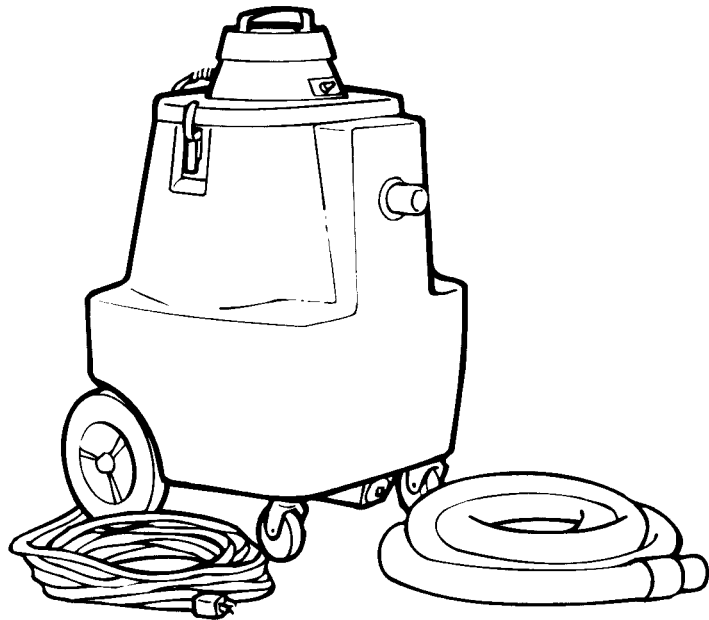

CASTEX
12875 RANSOM STREET
HOLLAND MI 49424 U.S.A.

FAX: 1-800-678-4240
CUSTOMER SERVICE: 1-800-964-9644

610198
Rev. 01 (06-00)

OPERATION

This manual is furnished with each new model. It provides necessary operation and maintenance instructions and a parts list.

Read this manual completely to understand the machine before operating or servicing.

When ordering replacement parts, use the illustrated parts list section in this manual. Before ordering parts or supplies, be sure to have your machine model number and serial number available. Parts and supplies may be ordered by phone or mail from any authorized Service Center or Distributor.

This machine will provide excellent service. However, the best results will be obtained at minimum costs if:

- The machine is operated with reasonable care.
- The machine is maintained regularly - per the maintenance instructions provided.
- The machine is maintained with manufacturer supplied or equivalent parts.

MACHINE DATA

Please fill out at time of installation for future reference.

Model No.- _____ Install. Date - / /

Serial No.- _____

© 2000 Tennant Company

Printed in U.S.A.

Castex is a registered trademark of Tennant Company.

TABLE OF CONTENTS

SAFETY PRECAUTIONS	3
GROUNDING INSTRUCTIONS	3
MACHINE COMPONENTS	4
MACHINE INSTALLATION	4
MACHINE SETUP AND OPERATION	4
MACHINE MAINTENANCE	5
RECOMMENDED STOCK ITEMS	5
TROUBLE SHOOTING	5
PARTS LIST	6
VACUUM HEAD GROUP	6
TANK GROUP	7
STANDARD ACCESSORIES	8
ELECTRICAL DIAGRAM	8
OPTIONS	9
HANDLE AND SQUEEGEE ATTACHMENT .	9

SAFETY PRECAUTIONS

This machine is intended for commercial use. It is designed for wet/dry vacuuming in an indoor environment and is not constructed for any other use. Use only recommended accessories.

All operators must read, understand and practice the following safety precautions:

The following safety alert symbols are used throughout this manual as indicated in their description.

⚠ WARNING: To warn of hazards or unsafe practices which could result in severe personal injury or death.

FOR SAFETY: To identify actions which must be followed for safe operation of equipment.

The following information signals potentially dangerous conditions to the operator or equipment:

FOR SAFETY:

1. **Do not operate machine:**
 - Unless trained and authorized.
 - Unless operator manual is read and understood.
 - In flammable or explosive areas.
 - Unless cord is properly grounded.
 - With the use of an extension cord.
 - With damaged cord or plug.
 - If not in proper operating condition.
 - In outdoor areas.
 - In standing water.
 - Without bag and/or filters in place.
2. **Before operating machine:**
 - Make sure all safety devices are in place and operate properly.
3. **When using machine:**
 - Do not run machine over cord.
 - Do not pull machine by plug or cord.
 - Do not pull cord around sharp edges or corners.
 - Do not unplug by pulling on cord.
 - Do not stretch cord.
 - Do not handle plug with wet hands.
 - Keep cord away from heated surfaces.
 - Do not pick up burning or smoking debris, such as cigarettes, matches or hot ashes.
 - Report machine damage or faulty operation immediately.

4. **Before leaving or servicing machine:**
 - Turn off machine.
 - Unplug cord from wall outlet.
5. **When servicing machine:**
 - Unplug cord from wall outlet.
 - Use manufacturer supplied or approved replacement parts.

⚠ WARNING: Hazardous Voltage. Shock or electrocution can result. Unplug machine before servicing.

⚠ WARNING: Flammable materials can cause an explosion or fire. Do not use flammable materials in tank.

⚠ WARNING: Flammable materials or reactive metals can cause an explosion or fire. Do not pick up.

GROUNDING INSTRUCTIONS

Machine must be grounded. If it should malfunction or breakdown, grounding provides a path of least resistance for electrical current to reduce the risk of electrical shock. This machine is equipped with a cord having an equipment-grounding conductor and grounding plug. The plug must be plugged into an appropriate outlet that is properly installed in accordance with all local codes and ordinances. Do not remove ground pin; if missing, replace plug before use.

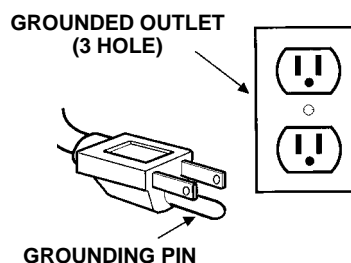

OPERATION

MACHINE COMPONENTS

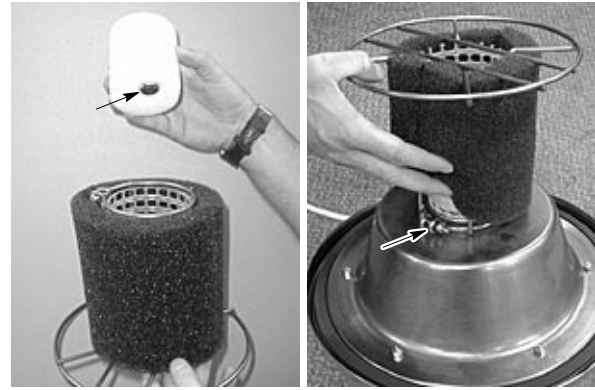
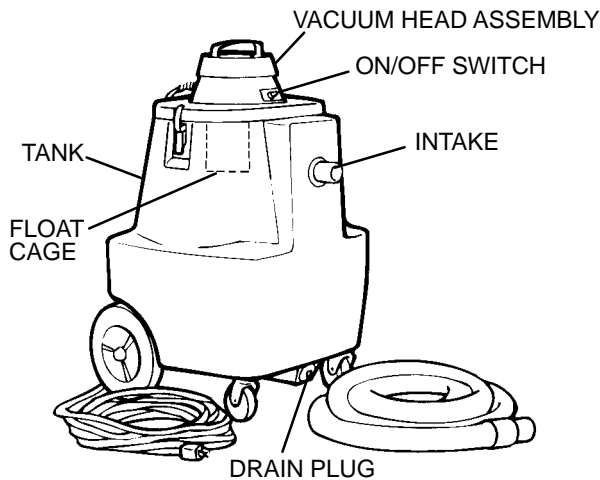

FIG. 1

MACHINE INSTALLATION

UNPACKING MACHINE

1. Carefully check carton for signs of damage. Report damages at once to carrier.
2. Carefully unpack and inspect vacuum for shipping damage. Each unit is tested and thoroughly inspected before shipment; any damage is the responsibility of delivering carrier. If damaged, notify carrier immediately.

MACHINE SETUP AND OPERATION

FOR SAFETY: Do not operate machine unless operator manual is read and understood.

1. Remove vacuum head and check that float and float cage assembly is installed.

To install float cage assembly: Place float inside cage with weighted bolt head facing away from vacuum head. Remove nut from tensioning screw on float cage. Snap cage onto bottom of vacuum head assembly. Thread nut onto tension screw and tighten until float cage is firmly attached to vacuum head (Figure 1).

2. For dry vacuuming, always use disposable paper filters in addition to cloth wet/dry filter bag. Disposable paper filters slide over intake elbow. For wet vacuuming, cloth filter bag may be used or removed.
3. Place vacuum head on top of tank and secure using clamps on either side of tank.
4. Attach swivel cuff end of hose to intake on front of tank.
5. Check drain plug on lower front of tank. Make sure plug is secure. If loose, tighten by turning clockwise.
6. Plug into a grounded 120 volt A.C. outlet (Figure 2)

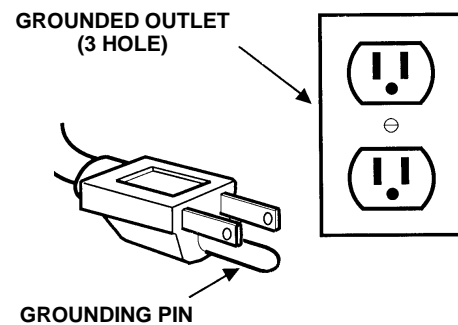

FIG. 2

FOR SAFETY: Do not operate machine unless cord is properly grounded, with the use of an extension cord or in flammable or explosive areas.

7. Turn on machine and begin vacuuming.

⚠ WARNING: Flammable materials or reactive metals can cause an explosion or fire. Do not pick up.

MACHINE MAINTENANCE

⚠ WARNING: Hazardous Voltage. Shock or electrocution can result. Unplug machine before servicing.

1. Clean or replace filter bag after every use. To clean, shake dust and debris from it. Periodically wash filter bag. Allow filter bag to dry completely before using. Using disposable paper bags will help keep filter bag clean.
2. Empty and rinse tank after every use.

⚠ WARNING: Flammable materials can cause an explosion or fire. Do not use flammable materials in tank.

3. Periodically remove filter frame assembly from vacuum head and inspect screen around float assembly for debris. Clean screen and reinstall filter frame assembly. Keep screen clean for best performance.

ATTENTION: If water is drawn into vacuum head, turn off power immediately. Remove vacuum head assembly from tank and place on floor. Turn on power for approximately three minutes to push water out of vacuum motor.

4. If vacuum performance decreases during operation, turn off power, remove vacuum head assembly from tank and inspect intake elbow for blockage. If intake area is open, check hose for blockage or damage.

RECOMMENDED STOCK ITEMS

Refer to Parts List section for recommended stock items. Stock Items are clearly identified with a bullet preceding the parts description. See example below:

Ref.	Part No.	Description	Qty.
1	201165	ASM_STANDPIPE	1
2	100513	•FLOAT, SHUTOFF	1
3	228187	•NIPPLE	1
4	101714	•GASKET	1
5	218248	NUT, FLANGED	1

TROUBLE SHOOTING

PROBLEM	CAUSE	SOLUTION
Motor does not operate.	Circuit overload.	Check breakers in building and re-set. Plug machine into a different circuit.
	Switch broken.	Contact Service Center.
	Loose or broken wiring.	Contact Service Center.
	Faulty vacuum motor.	Contact Service Center.
Little or no suction.	Hose is obstructed.	Clear debris from hose.
	Holes in hose.	Replace hose.
	Intake elbow is obstructed.	Remove base from elbow and remove clogging debris.
	Drain plug is loose or open.	Tighten drain plug.
	Vacuum head not securely latched to tank.	Latch both latches securely.
	Worn gasket is leaking air.	Inspect gaskets and replace.

PARTS LIST

VACUUM HEAD GROUP

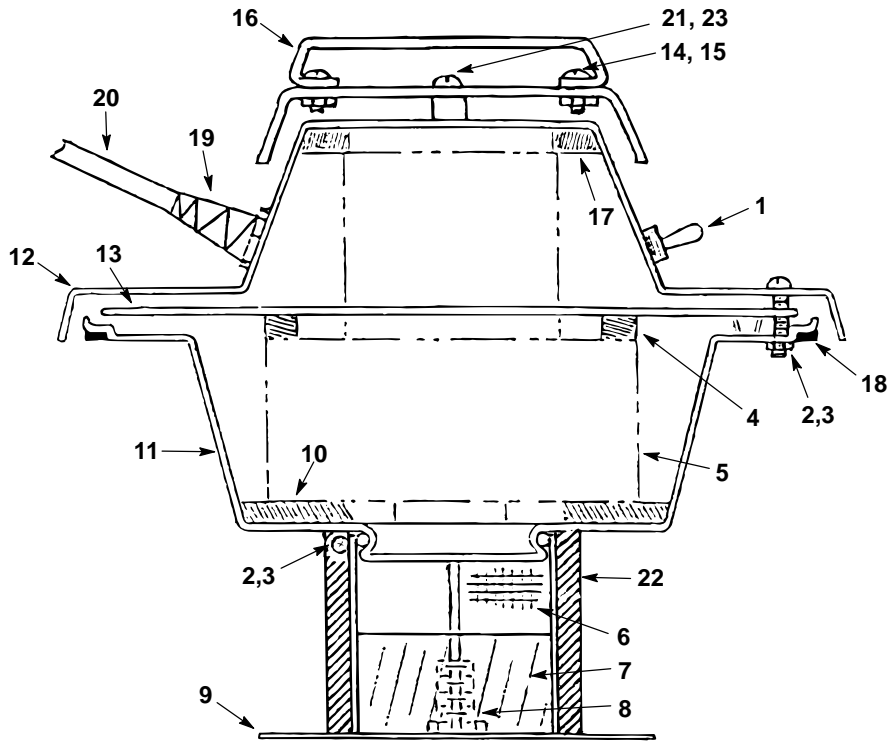

REF	PART #	DESCRIPTION	QTY.
1	MS859	●SWITCH, TOGGLE	1
2	140552	NUT, LOCK	7
3	MS111	SCREW, #10-24X1 SS	7
4	MS112	●GASKET	1
5	630187	●MOTOR, VAC 115V 1HP	1
	190155	CARBON BRUSH (2/PK)	2
	600435	MOTOR, VAC 220V 1HP	1
	600436	CARBON BRUSH (2/PK)	2
6	MS114	PLASTIC SCREEN	1
7	MS115	●FLOAT	1
8	MS116	●BOLT, FLOAT	1
9	MS117	●FLOAT CAGE	1
10	MS860	●GASKET	1
11	MS121	SPINNING, BOTTOM	1
12	MS861	SPINNING, OUTSIDE	1

REF	PART #	DESCRIPTION	QTY.
13	MS123	SPINNING, MOTOR	1
14	MS126	SCREW, 1/4"	2
15	MS127	NUT, 1/4"	2
16	MS863	HANDLE, TOP	1
17	MS129	●GASKET, TOP 5085	1
18	MS132	GASKET	1
29	130166	STRAIN RELIEF, CORD	1
20	MS865	CORD, POWER 25'	1
21	MS866	SCREW, TAPPING 1" (850)	3
22	MS163	FILTER, FOAM	1
23	MS867	●SPACER, 3/8"	3
N/S	MS864	WIRE CONNECTOR (NOT SHOWN)	1
N/S	578729	DECAL, READ MANUAL	1
N/S	630420	DECAL, FLAMMABLE MAT'L	1
N/S	610185	DECAL, HAZARD, UNPLUG	1

N/S NOT SHOWN

● RECOMMENDED STOCK ITEMS

TANK GROUP

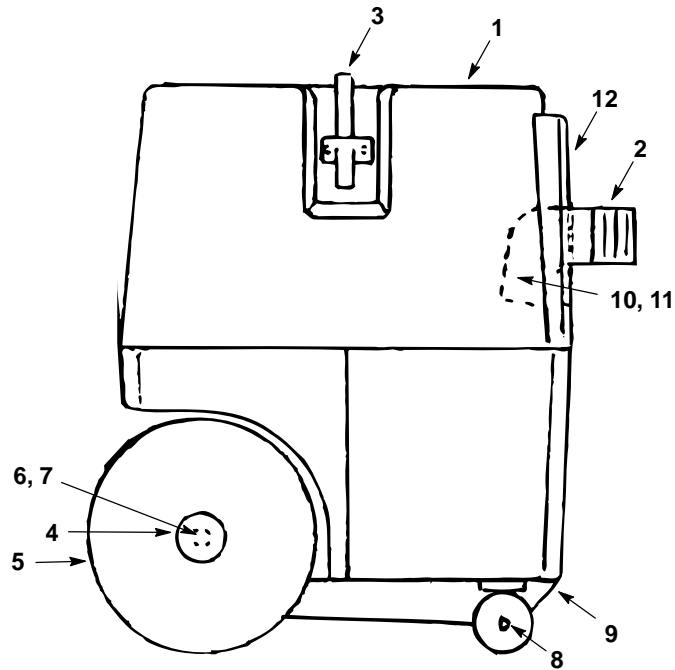

REF	PART #	DESCRIPTION	QTY.
1	610241	TANK, 15 GALLON	1
	610242	TANK, 10 GALLON	1
	610243	TANK, 5 GALLON	1
2	25202	●INTAKE	1
3	MS138	LATCH	2
4	MS140	CAP, HUB	2
5	MS869	WHEEL, 8"	2
6	MS871	AXLE, 15 GALLON TANK	1
	MS139	AXLE, 5/10 GALLON TANK	1

REF	PART #	DESCRIPTION	QTY.
7	610244	WASHER, FLAT 1/2"	2
8	MS142	●CASTER	2
9	MS108	●PLUG, DRAIN	1
10	MS144	ELBOW, DEFLECTOR	1
11	MS145	GASKET, INTAKE	1
12	610178	DECAL, "CASTEX WD85-15"	1
	610179	DECAL, "CASTEX WD85-10"	1
	610180	DECAL, "CASTEX WD85-05"	1

● RECOMMENDED STOCK ITEMS

PARTS LIST

STANDARD ACCESSORIES

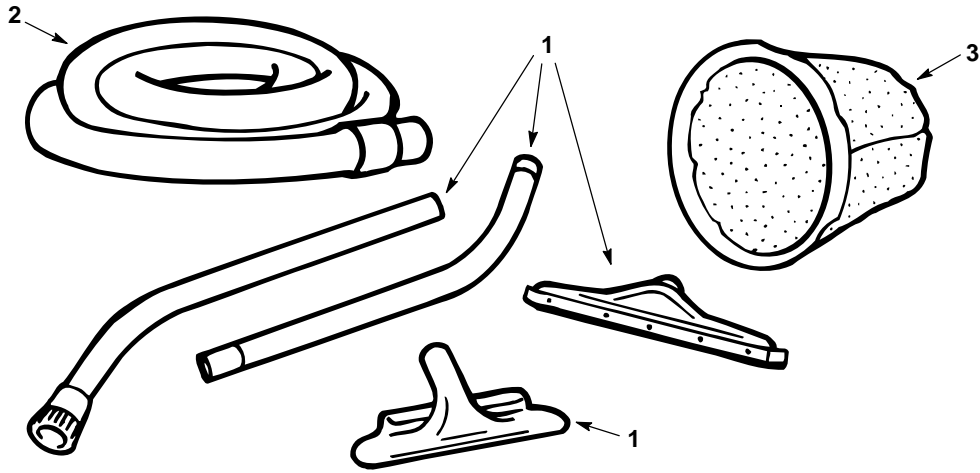

REF	PART #	DESCRIPTION	QTY.
▽1	190142	KIT, WAND TOOL W/ CARPET AND FLOOR ATTACHMENT	1
▲	190722	WAND, 2-PIECE	1
▲	605136	TOOL, RUG 11" W/ SLEEVE	1
▲	13840	SQUEEGEE, 14"	1

REF	PART #	DESCRIPTION	QTY.
2	160481	HOSE, 1 1/2" X 10' W/ SWIVEL CUFF	1
3	MS105	●BAG, CLOTH FILTER	1
	MS106	●BAG, PAPER FILTER (NOT SHOWN)	1
	MS148	●RING, BAG (NOT SHOWN)	1

▽ ASSEMBLY

▲ INCLUDED IN ASSEMBLY

● RECOMMENDED STOCK ITEMS

ELECTRICAL DIAGRAM

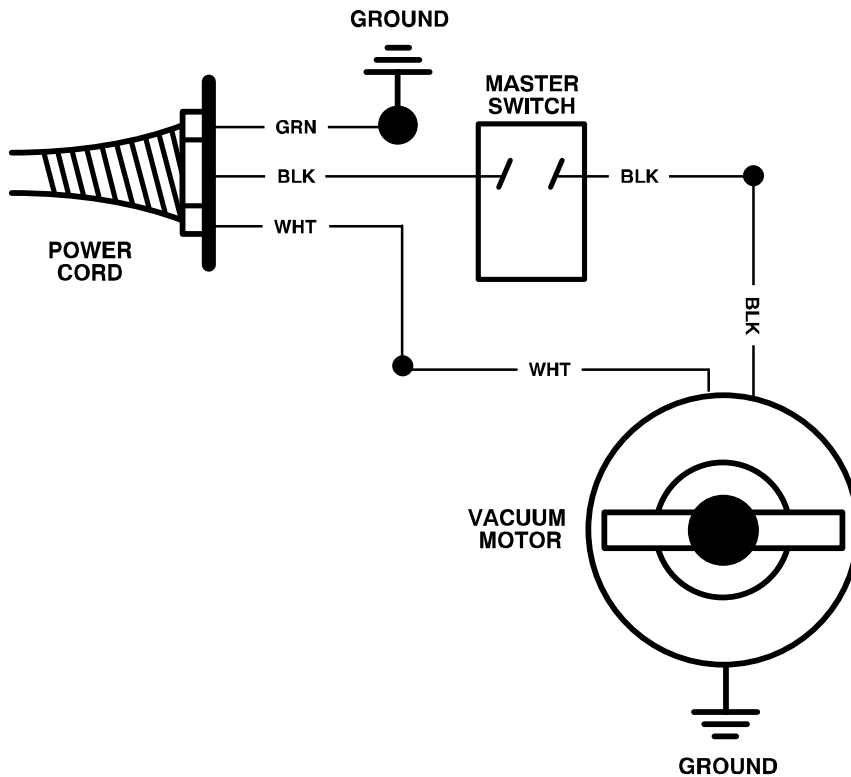

HANDLE AND SQUEEGEE ATTACHMENT, 762 mm (30 in)

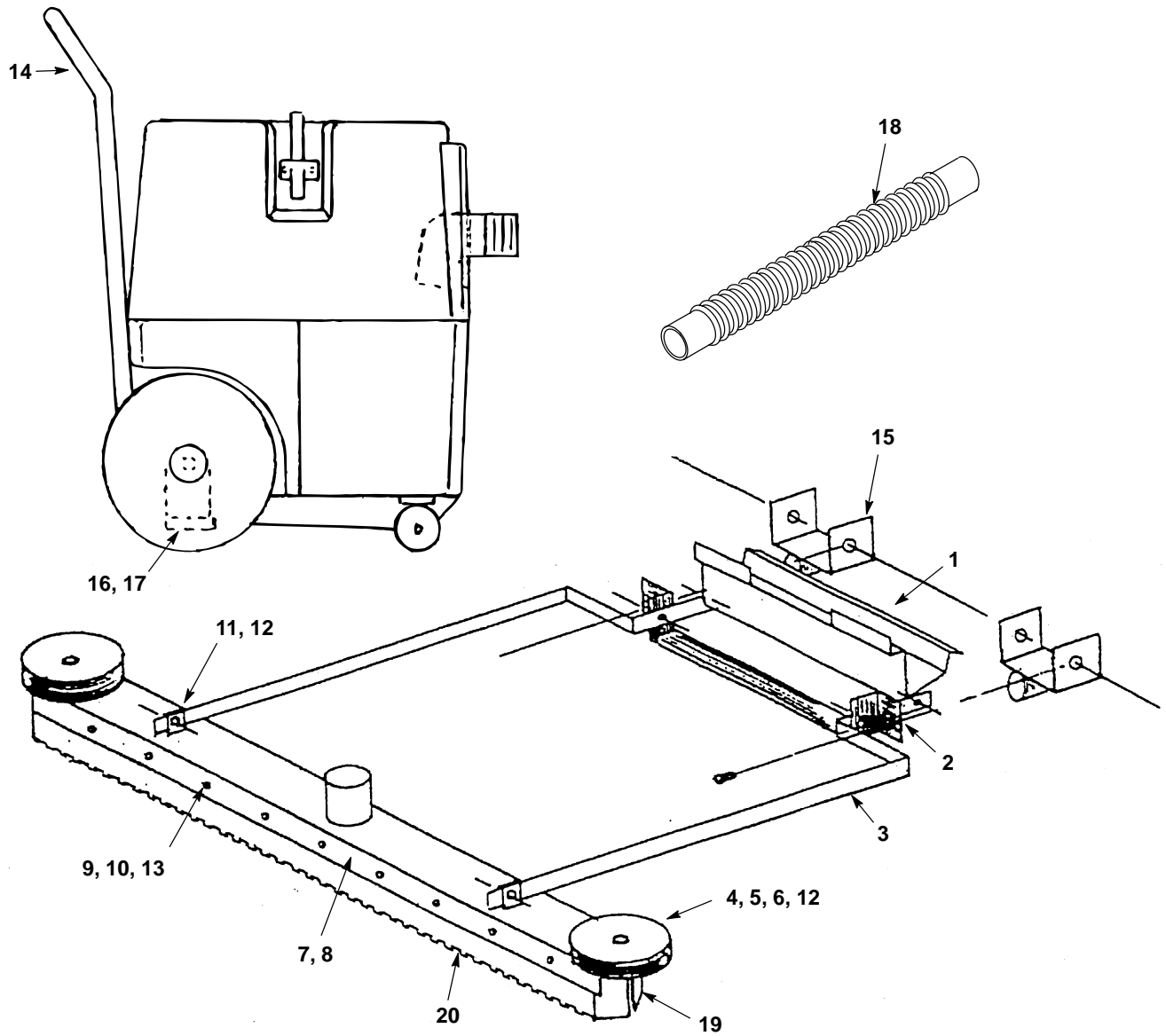

REF	PART #	DESCRIPTION	QTY.
∇	607001	KIT, HANDLE AND SQUEEGEE ATTACHMENT (COMPLETE)	1
▲1	MS149	PLATE, KICK	1
▲2	MS150	BRACKET, MOUNTING	1
▲3	MS151	ARM	2
▲4	MS152	WHEEL, BUMPER	2
▲5	610246	NUT, SERRATED	2
▲6	610247	BOLT, 1/4X1-3/4	2
▲7	MS154	MOUNT, CHANNEL	1
▲8	MS155	BAND, SQUEEGEE	2
▲9	MS156	SCREW, 10-24 X 3/4	20
▲10	MS157	NUT, LOCK 10-24	20
▲11	MS158	SCREW, 1/4-20	4

REF	PART #	DESCRIPTION	QTY.
▲12	MS159	NUT, LOCK 1/4-20	6
▲13	610248	SCREW, 10-24X5/8	4
▲14	MS513	HANDLE	1
▲15	MS146	BRACKET, HANDLE	2
▲16	MS870	SCREW, 3/8-16 X 1"	2
▲17	610245	WASHER, FLAT 3/8	2
▲18	MS162	HOSE W/ CUFFS 20"	1
▲19	MS103	●BLADE, SQUEEGEE	2
▲20	MS102	●BLADE, NOTCHED	2

∇ ASSEMBLY

▲ INCLUDED IN ASSEMBLY

● RECOMMENDED STOCK ITEMS