

Castex®

WV-1200 WV-1200P WV-1600

Wet/Dry Vacuum

Model No.:

607778 – WV-1200

607346 – WV-1200P

607345 – WV-1600

Operator and Parts Manual



CASTEX INCORPORATED
12875 RANSOM STREET
HOLLAND MI 49424 U.S.A.

A TENNANT COMPANY

1-800-522-7839
616-786-2330
FAX: 1-800-678-4240
CUSTOMER SERVICE: 1-800-964-9644

607584
Rev. 00 (04-99)

120V

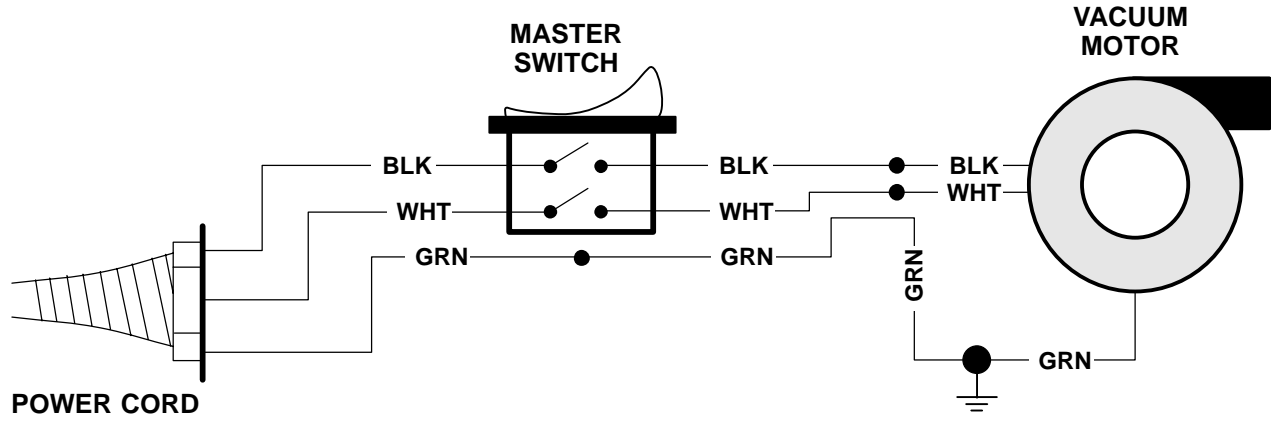

TANK GROUP

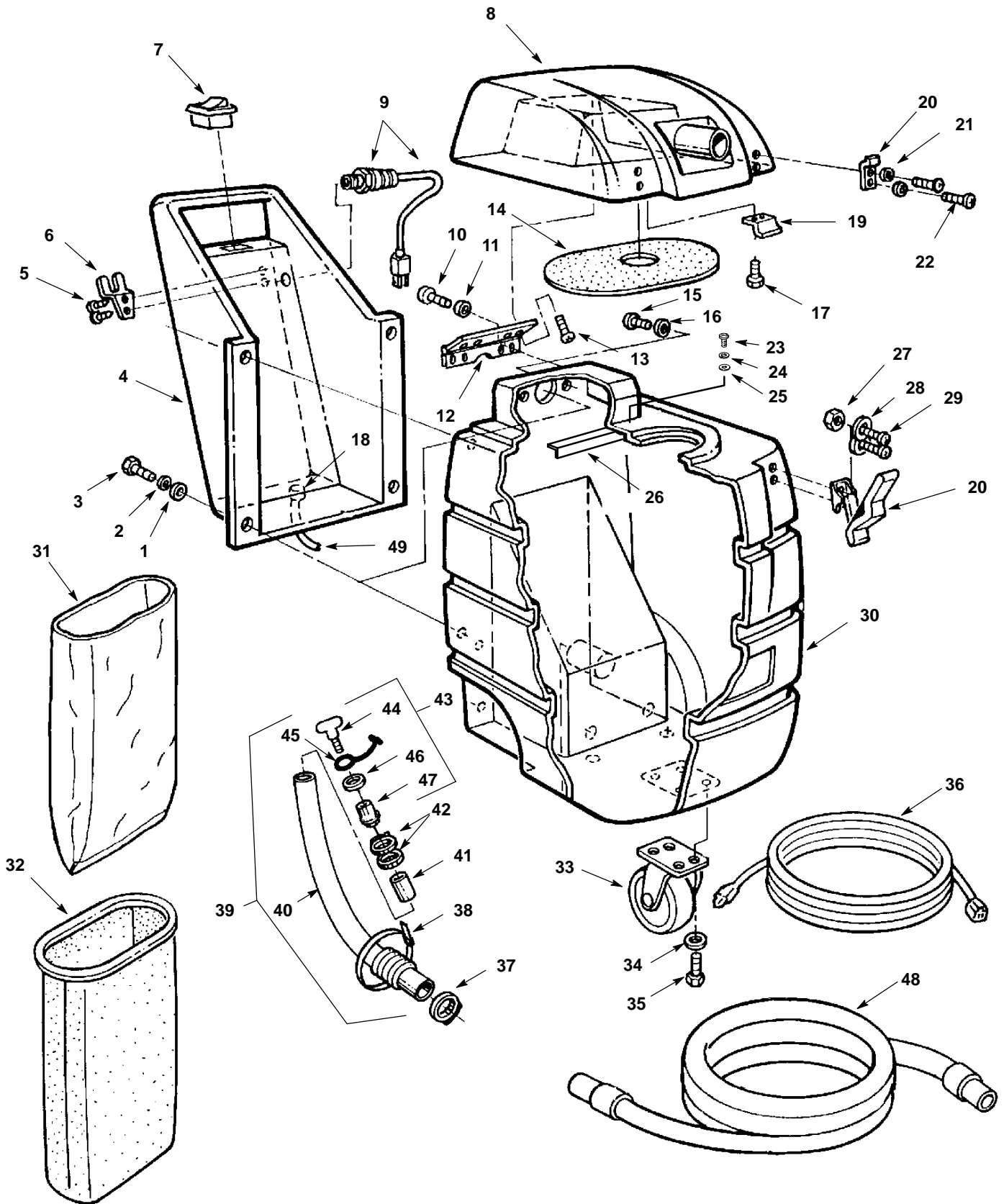

TANK GROUP

REF	PART #	DESCRIPTION	QTY.
1	140028	WASHER, FLAT	4
2	140017	WASHER, LOCK	4
3	140231	SCREW, 3/8-16X1 1/2	4
4	100379	HANDLE, BLUE	1
5	140825	SCREW, #6X1/2	2
6	230696.BK	HANGER, DRAIN HOSE	1
7	19417	SWITCH	1
8	100375	COVER, BLUE (12 GAL. MODEL)	1
	607374	COVER, BLUE (16 GAL. MODEL)	1
9	130201	ASM., CORD 16/3X28" (120V)	1
10	140195	SCREW, 1/4-20X1/2	4
11	140000	WASHER, FLAT	4
12	230458	HINGE, COVER (12 GAL. MODEL)	1
	230318	HINGE, COVER (16 GAL. MODEL)	1
13	140195	SCREW, 1/4-20X1/2	4
14	100098	GASKET, COVER (12 GAL. MODEL)	1
	100097	GASKET, COVER (16 GAL. MODEL)	1
15	140824	SCREW, 1/4-20X5/8	2
16	578244000	WASHER, LOCK	2
17	140197	SCREW, 10-24X3/8	2
18	130110	BUSHING, STRAIN RELIEF	1
19	230497	BRACKET, AIR DEFLECTOR	1
20	140932	LATCH, RUBBER & KEEPER	2
	140953	LATCH, CHROME (PUMP-OUT MODEL)	2
	230512	KEEPER (PUMP-OUT MODEL)	2
21	140023	WASHER, LOCK	4
22	140801	SCREW, 8-32X3/8	4
23	140824	SCREW, 1/4-20X5/8 (16 GAL. MODEL)	2
24	578244000	WASHER, LOCK (16 GAL. MODEL)	2
25	140003	WASHER, FENDER (16 GAL. MODEL)	2
26	230482.BK	BRACKET, SUPPORT (16 GAL. MODEL)	1
27	28990	NUT, LOCK	4

REF	PART #	DESCRIPTION	QTY.
28	140011	WASHER, FLAT	4
29	140802	SCREW, 8-32X5/8	4
30	608001	TANK, BLUE (12 GAL. MODEL)	1
	100377	TANK, BLUE (12 GAL. W/PUMPOUT)	1
	607349	TANK, BLUE (16 GAL. MODEL)	1
31	900102	BAG, PAPER	1
32	900104	BAG, CLOTH (12 GAL. MODEL)	1
	900105	BAG, CLOTH (16 GAL. MODEL)	1
33	103065	CASTER, SWIVEL	1
34	140015	WASHER, LOCK	4
35	140226	SCREW, 5/16-18X5/8	4
36	130250	CORD, 16/3X50'	1
37	140307	CLAMP	1
38	130041	WIRE TIE	1
▽39	701058	ASM., DRAIN HOSE	1
▲40	160457	HOSE, DRAIN	1
▲41	140921	SLEEVE	1
▲42	140072	CLAMP	2
▽▲43	701061	ASM., PLUG	1
▲44	230831	KNOB	1
▲45	230882	STRAP	1
▲46	140056	WASHER, FENDER	1
▲47	140955	PLUG	1
48	160481	HOSE, VACUUM	1
49	130267	CORD, HANDLE 16/3X30"	1

▽ ASSEMBLY

▲ INCLUDED IN ASSEMBLY

DECAL LIST

REF	PART #	DESCRIPTION	QTY.
N/S	120101	DECAL, CASTEX	1
N/S	602596	DECAL, WARNING	1
N/S	120657	DECAL, PUMP-OUT INST.	1
N/S	607572	DECAL, WV-1200	2
N/S	607924	DECAL, WV-1200P	2
N/S	607573	DECAL, WV-1600	2

BASE GROUP

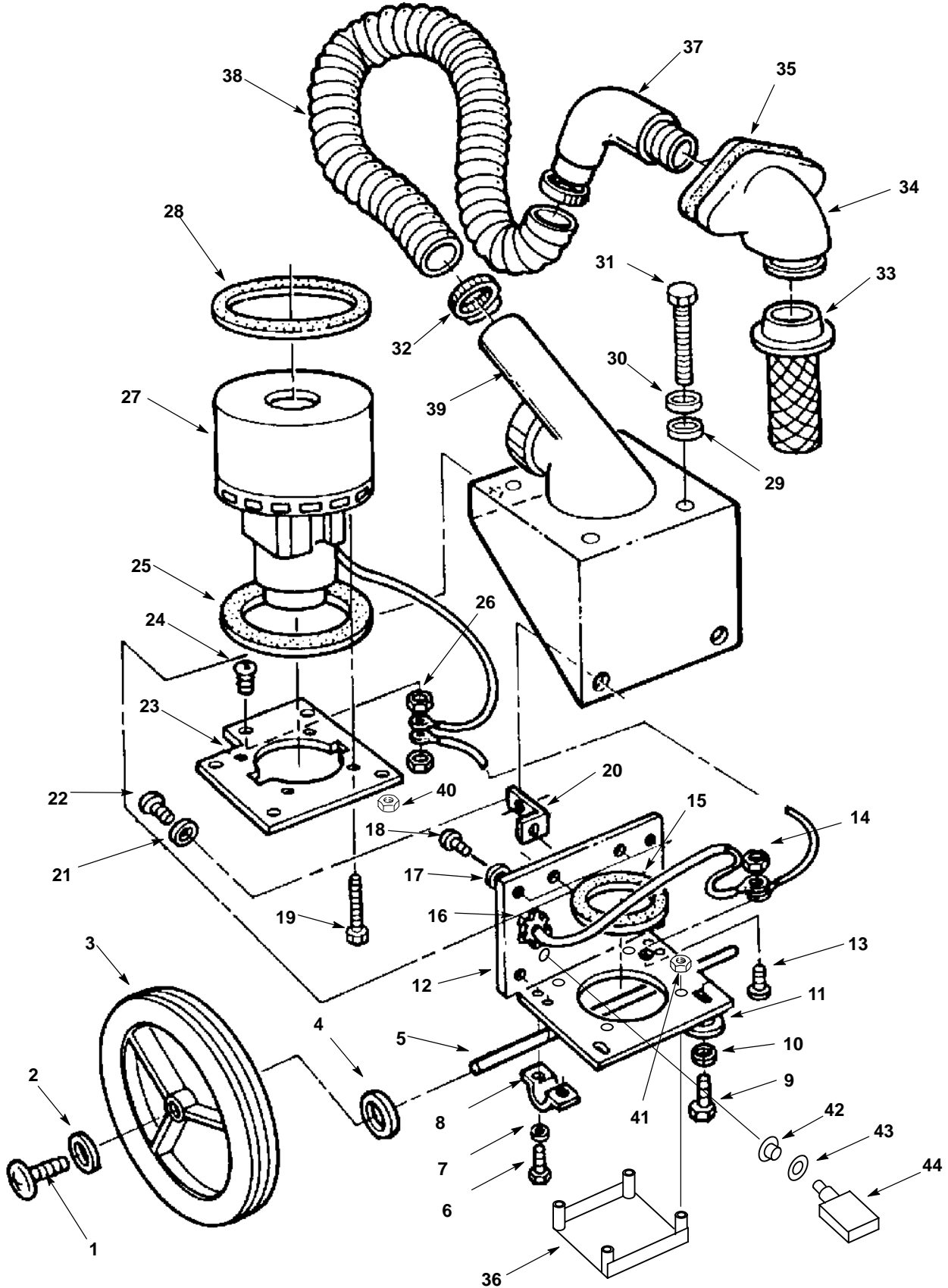

BASE GROUP

REF	PART #	DESCRIPTION	QTY.
1	140195	SCREW, 1/4-20X1/2	2
2	140003	WASHER, FENDER	2
3	103036	WHEEL (12 GAL. MODEL)	2
	103060	WHEEL (16 GAL. MODEL)	2
4	140045	WASHER, FLAT	2
5	230457	AXLE (12 GAL. MODEL)	1
	230317	AXLE (16 GAL. MODEL)	1
6	140553	SCREW, 1/4-20X1/2	4
7	140016	WASHER, LOCK	4
8	230746	BRACKET, AXLE	2
9	140201	SCREW, 3/8-16X3/4	2
10	140017	WASHER, LOCK	2
11	140028	WASHER, FLAT	2
12	230350.BK	PLATE, COVER (12 GAL. MODEL)	1
	230486.BK	PLATE, COVER (16 GAL. MODEL)	1
13	140900	SCREW, 10-24X3/4	1
14	140519	NUT, KEP	3
15	100095	GASKET, VAC MOTOR	1
16	140504	NUT, CONDUIT	1
17	140000	WASHER, FLAT	5-6
18	140195	SCREW, 1/4-20X1/2	5-6
19	140340	SCREW, #10X5/8	4
20	230496.BK	SUPPORT, DRAIN HOSE	1
21	578244000	WASHER, LOCK	2
22	140824	SCREW, 1/4-20X5/8	2
23	230522	BRACKET, MOTOR MOUNT	1
24	140900	SCREW, 10-24X3/4	1
25	100143	GASKET, MOTOR	1
26	140519	NUT, KEP	3

REF	PART #	DESCRIPTION	QTY.
27	130406	MOTOR, VACUUM 120V (WV-1200/WV-1600)	1
	190155	-BRUSH, CARBON (2/PK)	2
	130415	MOTOR, VACUUM 120V (WV-1200P)	1
	190161	-BRUSH, CARBON (2/PK)	2
28	100038	GASKET, MOTOR	1
29	140003	WASHER, FENDER	4
30	578244000	WASHER, LOCK	4
31	25157.32	SCREW, 1/4-20X4 (WV-1200/1600)	4
32	140308	CLAMP	2
33	180613	FLOAT, SCREEN SHUT-OFF	1
34	100381	ELBOW, VACUUM TUBE	1
35	100096	GASKET, VACUUM TUBE	1
36	602674	GUARD, VACUUM MOTOR (WV-1200/1600)	1
37	700435	ELBOW	1
38	160482	HOSE, VACUUM	1
39	100380	MOUNT, VACUUM MOTOR	1
	100302	MOUNT, VAC. MOTOR (PUMP-OUT MODEL)	1
40	140501	NUT, LOCK	4
41	12481	NUT	4
42	130164	PLUG, DOME (220V)	1
43	140022	WASHER, LOCK (120V)	1
44	611110000	BREAKER, CIRCUIT 10A	1
	130670	BREAKER, CIRCUIT 12A (PUMP-OUT MODEL)	1

PUMP-OUT GROUP

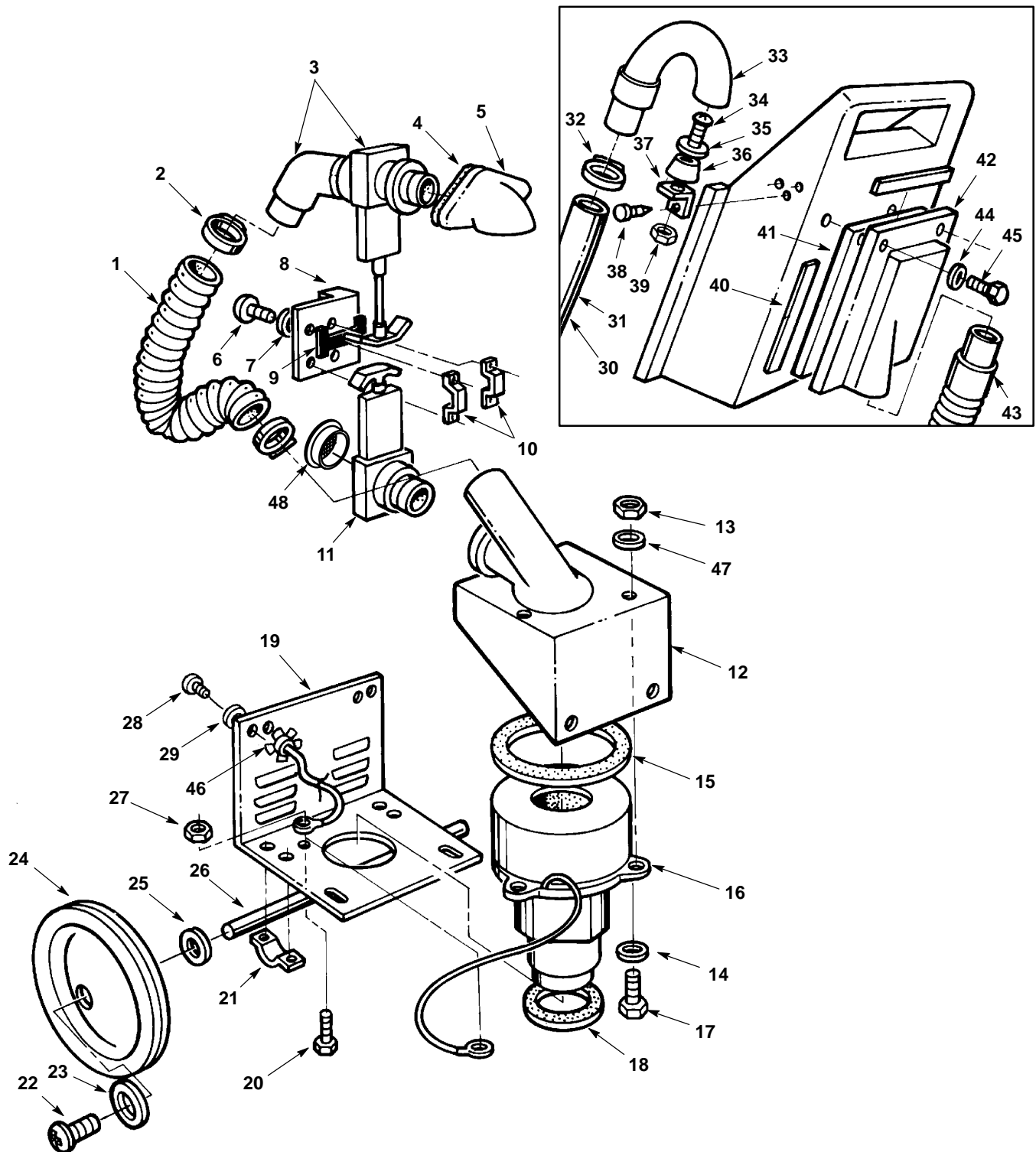

PUMP-OUT GROUP

REF	PART #	DESCRIPTION	QTY.
1	160482	HOSE, VACUUM	1
2	140308	CLAMP	2
3	700461	VALVE, GATE	1
4	100096	GASKET,VAC TUBE	1
5	100381	ELBOW,VAC TUBE	1
6	140837	SCREW, 10-24X3/8	4
7	140018	WASHER, LOCK	4
8	230334	HANDLE, AIR VALVE	1
9	230493	SPACER	1
10	230338	BRACKET, AIR VALVE	2
11	210231	VALVE, DRAIN	1
12	100302	HOUSING, VACUUM MOUNT	1
13	140501	NUT, LOCK	3
14	140000	WASHER, FLAT	3
15	100038	GASKET, VACUUM MOTOR	1
16	130415	MOTOR, VACUUM 120V	1
	190161	BRUSH, CARBON (2/PK)	1
17	2998.28	SCREW, 1/4-20X3 1/2	3
18	100095	GASKET, VACUUM MOTOR	1
19	231033.BK	PLATE, COVER (12 GAL. MODEL)	1
	230331.BK	PLATE, COVER (16 GAL. MODEL)	1
20	140900	SCREW, 10-24X3/4	1
21	230746	BRACKET, AXLE	2
22	140195	SCREW, 1/4-20X1/2	2
23	140003	WASHER, FENDER	2
24	103060	WHEEL	2
25	140063	WASHER, FLAT	2
26	230457	AXLE (12 GAL. MODEL)	1
	230317	AXLE (16 GAL. MODEL)	1
27	140519	NUT,, KEP	3
28	140195	SCREW, 1/4-20X1/2	6
29	140000	WASHER, FLAT	6

REF	PART #	DESCRIPTION	QTY.
∇30	701059	ASM., DRAIN HOSE PUMPOUT	1
▲31	160458	HOSE, DRAIN	1
▲32	140307	CLAMP	1
▲33	230357	DOWNSPOUT, PVC 1 1/2"	1
34	140899	SCREW, 10-24X1 1/4	1
35	140011	WASHER, FLAT	1
36	140950	PLUG, DRAIN HOSE	1
37	230394.BK	BRACKET, DRAIN HOSE	1
38	140825	SCREW, #6X1/2	3
39	140522	NUT, LOCK 3/8-16	1
40	607498	TAPE, BUMPER 1/16X1 (3.2 FT)	1
41	102531	FILTER, FOAM	1
42	602775	HOUSING, FILTER, BLUE	1
43	160459	HOSE, VAC W/CUFF	1
	230905	TUBE, INLET	1
44	140012	WASHER, FLAT	4
45	140341	SCREW, #10X1	4
46	140504	NUT, COUDUIT	1
47	140000	WASHER, FENDER	3
48	602744	SCREEN, GATEVALVE	1

∇ ASSEMBLY

▲ INCLUDED IN ASSEMBLY

SQUEEGEE KIT BREAKDOWN

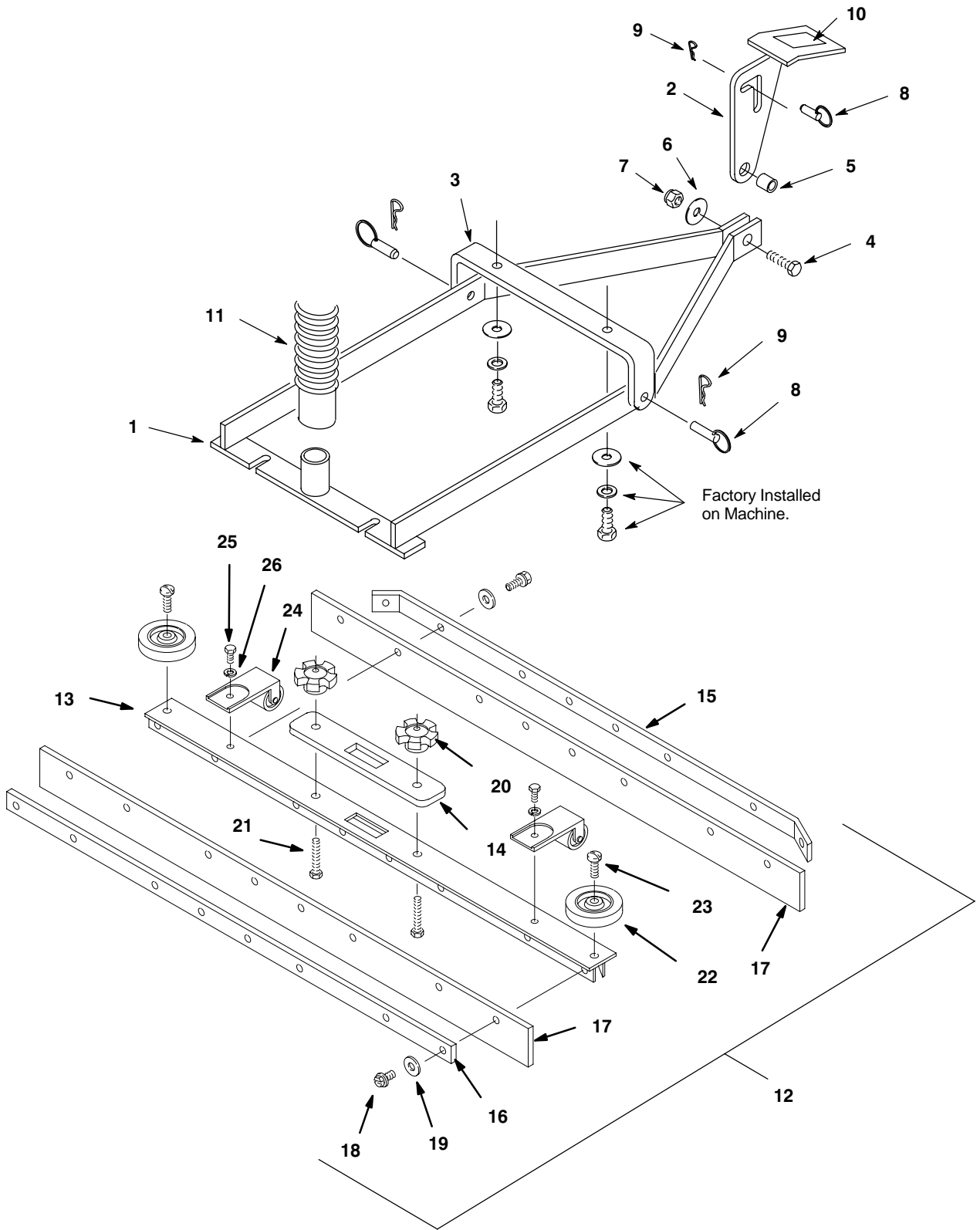

SQUEEGEE KIT BREAKDOWN

REF	PART #	DESCRIPTION	QTY.
▽	190108	SQUEEGEE KIT 67CM (26 IN)	1
	190972	SQUEEGEE KIT 84CM (33 IN)	1
	190958	SQUEEGEE KIT 99CM (39 IN)	1
▲1	230453.BK	WELDMENT, SQUEEGEE LIFT	1
▲2	230456	PEDAL, LIFT	1
▲3	230454	BRACKET, SQUEEGEE MOUNT	1
▲4	140232	SCREW, 3/8-16X1-1/4	1
▲5	140925	SPACER, 3/16	1
▲6	140028	WASHER, FLAT 3/8	1
▲7	140515	NUT, LOCK NYLON 3/8-16	1
▲8	630258	PIN, CLEVIS	3
▲9	612254000	PIN, HAIR	3
▲10	102560	PAD, NONSTICK	1
▲11	160462	HOSE, VACUUM 1.5 X 84CM (33 IN)	1
▲12	602831	ASM., SQUEEGEE 67CM (26 IN)	1
	603494	ASM., SQUEEGEE 84CM (33 IN)	1
	603496	ASM., SQUEEGEE 99CM (39 IN)	1
▲13	230727.BK	WELDMENT, SQUEEGEE 67CM (26 IN)	1
	230682.BK	WELDMENT, SQUEEGEE 84CM (33 IN)	1
	230692.BK	WELDMENT, SQUEEGEE 99CM (39 IN)	1

REF	PART #	DESCRIPTION	QTY.
▲14	100150	GASKET	1
▲15	230725.BK	PLATE, REAR 67CM (26 IN)	1
	230669.BK	PLATE, REAR 84CM (33 IN)	1
	230685.BK	PLATE, REAR 99CM (39 IN)	1
▲16	230723.BK	PLATE, FRONT 67CM (26 IN)	1
	230670.BK	PLATE, FRONT 84CM (33 IN)	1
	230686.BK	PLATE, FRONT 99CM (39 IN)	1
▲17	603659	BLADE, SQUEEGEE 67CM (26 IN)	2
	603661	BLADE, SQUEEGEE 84CM (33 IN)	2
	603662	BLADE, SQUEEGEE 99CM (39 IN)	2
▲18	140890	SCREW, 10-24X1/2	18-28
▲19	140018	WASHER, #10 INT LOCK	18-28
▲20	27257	KNOB, SQUEEGEE	2
▲21	140221	SCREW, 5/16-18X1-1/4	2
▲22	630450	WHEEL	2
▲23	140799	SCREW, 5/16-18X1-1/2	2
▲24	700844	ASM., SQUEEGEE ROLLER	2
▲25	140226	SCREW, 5/16-18X5/8	2
▲26	140015	WASHER, LOCK	2

▽ ASSEMBLY

▲ INCLUDED IN ASSEMBLY

OPTIONAL ACCESSORIES

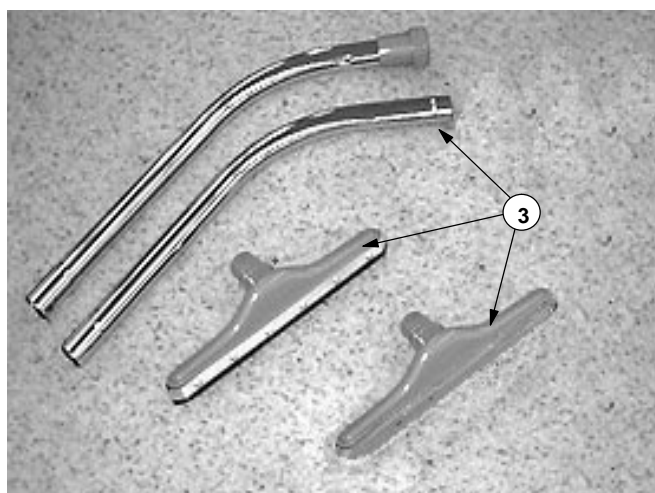
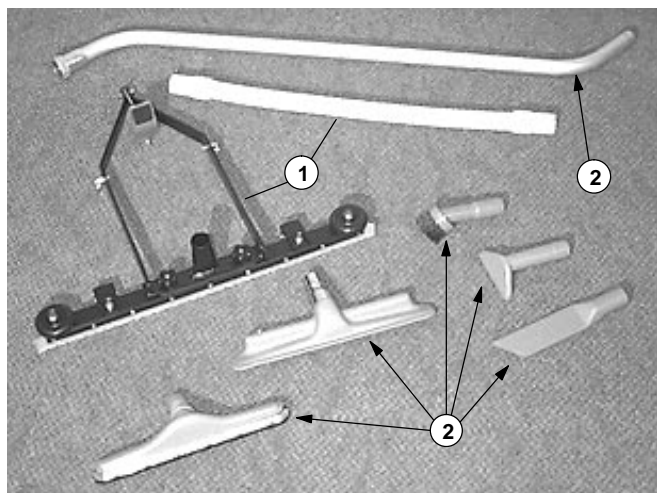

REF	PART #	DESCRIPTION	QTY.
1	190108	KIT, 66CM (26 IN) SQUEEGEE	1
	190972	KIT, 84CM (33 IN) SQUEEGEE	1
	190958	KIT, 99CM (39 IN) SQUEEGEE	1
2	16593	VKIT, ACCESSORY TOOL	1
	6108.1	▲TWO PIECE WAND	1
	6117	▲DUSTING BRUSH	1
	6057	▲10CM (4 IN) UPHOLSTERY TOOL	1
	6170	▲CREVICE TOOL	1
	14043	▲41CM (16 IN) FLOOR TOOL	1
	13840	▲SQUEEGEE TOOL	1

REF	PART #	DESCRIPTION	QTY.
3	190142	VKIT, ACCESSORY TOOL	1
	190722	▲TWO PIECE WAND	1
	603840	▲36CM (14 IN) CARPET TOOL SCALLOPED FACE	1
	13840	▲36CM (14 IN) SQUEEGEE TOOL	1

▽ ASSEMBLY

▲ INCLUDED IN ASSEMBLY