

Read Operation Instructions
before using the machine.



Read the Safety Messages
before using the machine.



Frame Assembly	4
Frame Assembly - Bottom View	5
Actuator & Frame Support.....	6
Caster Foot Assembly	7
Squeegee Drag Link.....	8
Squeegees	9
Batteries & Chargers	10
26" & 28" Disk Decks	11
Jaws Assembly - Right Side	12
Jaws Assembly - Left Side.....	13
Disk Shrouds	14
25" & 29" Cylindrical Decks.....	15
Cylindrical Door Assembly.....	16
Standard Tank Assembly	17
Standard Tank - Drain Saver, Vac Box, Baffle Assembly.....	18
Standard Tank - Vacuum Bandeau Assembly	19
Standard Tank - Lid Assembly	20
XL Tank Assembly	21
XL Tank - Drain Saver, Vac Box, Baffle Assembly	22
XL Tank - Vacuum Bandeau Assembly	23
XL Tank - Lid Assembly	24
Central Command Assembly	25
Common Wear Parts	26
Common Wear Parts	27
Tank Stickers	28

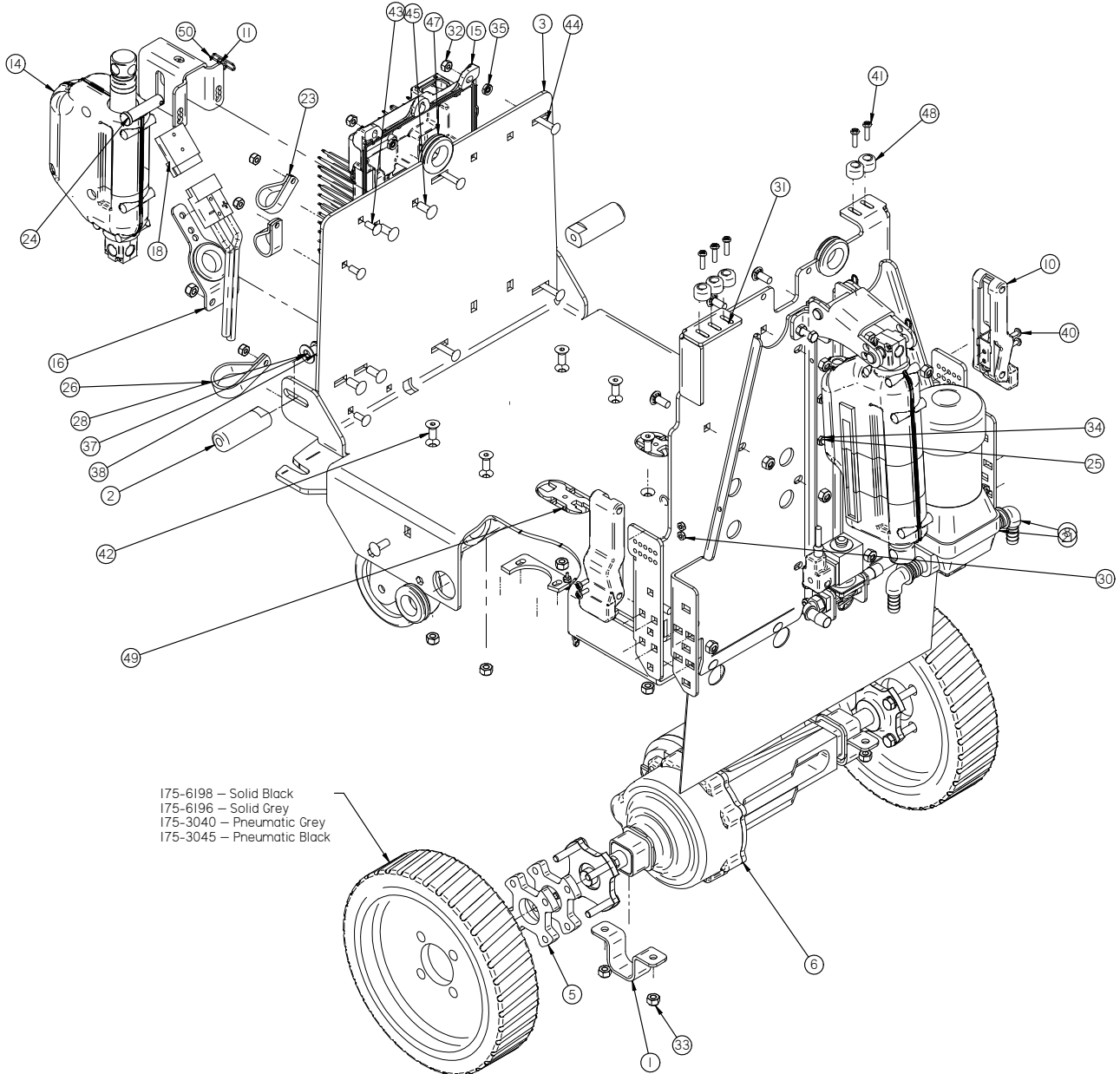

Item	Part No.	Part Description	Qty.	Item	Part No.	Part Description	Qty.
1	175-0999	AXLE MOUNT	2	30	H-70856	NYLOK #8-32 SS	4
2	175-1060	2-3/4" BOSS	2	31	H-70858	NYLOK #10-32 SS	9
3	175-1100	MAINFRAME WELDMENT	1	32	H-70860	NYLOK 1/4"- 20 SS	11
4	175-1370	SIGHT TUBE	1	33	H-70861	NYLOK 5/16"- 18 SS	35
5	175-3001	PNUMATIC TIRE SPACER	2	34	H-70923	KN #10-32 SS	4
6	175-3009	TRANSAXLE 19.4:1	1	35	H-70925	KN 1/4-20 S/S	4
7	175-9130	INLINE FILTER	1	36"	H-71010	FW #10 ID X 11/16 OD SS	4
8	21-1601	1/2" BARBED ELBOW (PLASTIC)	2	37	H-71017	FW 3/8 ID X 7/8 OD SS	2
9	21-1606	1/2 MALE NPT X 1/2" BARB	1	38	H-71067	LW 3/8" SS	2
10	250-1240	LATCH	2	39	H-72388	PPH #6-32 X 3/4" SS	1
11	253-1099	AUTO SQUEEGEE LIFT BRACKET	1	40	H-72398	PPH #8-32 X 1/2" S/S	4
12"	253-1245	BUSHING	8	41	H-72416	PPHMS #10-32 X 3/4" S/S	5
13	253-1618	GROUNDING CHAIN, 12"	1	42	H-73907	FHSCS 5/16"- 18 X 3/4" SS	5
14	253-2240	2" STROKE 24V ACTUATOR 450 LB LOAD	1	43	H-74418	CB 1/4"- 20 X 5/8" S/S	3
15	264-2440	ONBOARD CHARGER	1	44	H-74421	CB 1/4"- 20 X 1-1/4" SS	4
16	264-9516	CHARGER CONECTOR BRACKET	1	45	H-74429	CB 5/16"- 18 X 3/4" SS	20
17	290-8960	SPRAY JET HOSE	1	46"	H-74430	CB 5/16"- 18 X 1" SS	4
18	4-259	CONNECTOR, RED 50, HOUSING ONLY	2	47	H-9307K74	GROMMET, 1" ID X 1-3/4" OD BUNA-N	5
19	5-446	1/2" PLASTIC BARB TEE	1	48	H-9540	RUBBER BUMPER, 25/32"	5
20	5-447	1/2 NPT X 1/2" BARB ELBOW	1	49	H-NJ05C	JNYL 5/16"- 18 SS	2
21	5-891	PUMP, WATER JET	1	50	H-RUE22	1/2" RUE RING COTTER	1
22"	H-00918	HCN 1/4"-20 LG	4	51"	M-3043T13	1/4-20 X 1.0" U-BOLT	2
23	H-0127295	RUBBER LOOP CLAMP, 3/4"	2	52	M-5463K727	WYE, 1/2", NYLON	1
24	H-0156771	CLEVIS PIN, 1/2" OD X 2" LG	1	53	T-050R0250	1/2"ID X 27"LG SOLUTION HOSE	1
25	H-0172522	CB #10-32 X 1-1/4" SS	4	54	T-050R1450	1/2"ID X 27"LG SOLUTION HOSE	1
26	H-3225T	RUBBER LOOP CLAMP, 1-1/2"	1	55	T-050R1600	1/2"ID X 27"LG SOLUTION HOSE	1
27"	H-33733	#6 STAR WASHER	2	56	T-050R2700	1/2"ID X 27"LG SOLUTION HOSE	1
28	H-70105	HCS 3/8"- 16 X 1" SS	2	57	T-050R2700	1/2"ID X 27"LG SOLUTION HOSE	1
29"	H-70855	NYLOK #6-32 SS	1				

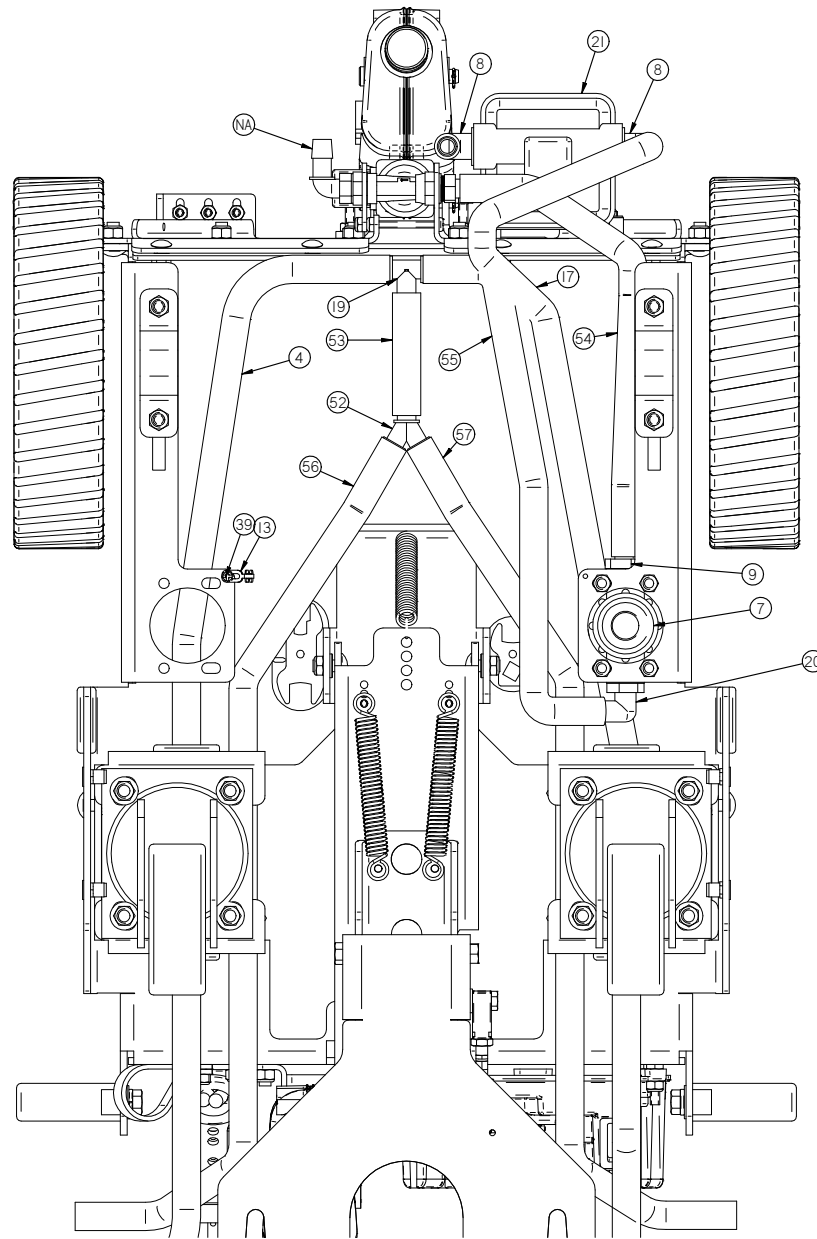

Item	Part No.	Part Description	Qty.	Item	Part No.	Part Description	Qty.
1	175-0999	AXLE MOUNT	2	30	H-70856	NYLOK #8-32 SS	4
2	175-1060	2-3/4" BOSS	2	31	H-70858	NYLOK #10-32 SS	9
3	175-1100	MAINFRAME WELDMENT	1	32	H-70860	NYLOK 1/4"- 20 SS	11
4	175-1370	SIGHT TUBE	1	33	H-70861	NYLOK 5/16"- 18 SS	35
5	175-3001	PNUMATIC TIRE SPACER	2	34	H-70923	KN #10-32 SS	4
6	175-3009	TRANSAXLE 19.4:1	1	35	H-70925	KN 1/4-20 S/S	4
7	175-9130	INLINE FILTER	1	36	H-71010	FW #10 ID X 11/16 OD SS	4
8	21-1601	1/2" BARBED ELBOW (PLASTIC)	2	37	H-71017	FW 3/8 ID X 7/8 OD SS	2
9	21-1606	1/2 MALE NPT X 1/2" BARB	1	38	H-71067	LW 3/8" SS	2
10	250-1240	LATCH	2	39	H-72388	PPH #6-32 X 3/4" SS	1
11	253-1099	AUTO SQUEEGEE LIFT BRACKET	1	40	H-72398	PPH #8-32 X 1/2" S/S	4
12	253-1245	BUSHING	8	41	H-72416	PPHMS #10-32 X 3/4" S/S	5
13	253-1618	GROUNDING CHAIN, 12"	1	42	H-73907	FHSCS 5/16"- 18 X 3/4" SS	5
14	253-2240	2" STROKE, 24V ACTUATOR 450 LB LOAD	1	43	H-74418	CB 1/4"- 20 X 5/8" S/S	3
15	264-2440	ONBOARD CHARGER	1	44	H-74421	CB 1/4"- 20 X 1-1/4" SS	4
16	264-9516	CHARGER CONECTOR BRACKET	1	45	H-74429	CB 5/16"- 18 X 3/4" SS	20
17	290-8960	SPRAY JET HOSE	1	46	H-74430	CB 5/16"- 18 X 1" SS	4
18	4-259	CONNECTOR, RED 50, HOUSING ONLY	2	47	H-9307K74	GROMMET, 1" ID X 1-3/4" OD BUNA-N	5
19	5-446	1/2" PLASTIC BARB TEE	1	48	H-9540	RUBBER BUMPER, 25/32"	5
20	5-447	1/2 NPT X 1/2" BARB ELBOW	1	49	H-NJ05C	JNYL 5/16"- 18 SS	2
21	5-891	PUMP, WATER JET	1	50	H-RUE22	1/2" RUE RING COTTER	1
22	H-00918	HCN 1/4"-20 LG	4	51	M-3043T13	1/4-20 X 1.0" U-BOLT	2
23	H-0127295	RUBBER LOOP CLAMP, 3/4"	2	52	M-5463K727	WYE, 1/2", NYLON	1
24	H-0156771	CLEVIS PIN, 1/2" OD X 2" LG	1	53	T-050R0250	1/2"ID X 27"LG SOLUTION HOSE	1
25	H-0172522	CB #10-32 X 1-1/4" SS	4	54	T-050R1450	1/2"ID X 27"LG SOLUTION HOSE	1
26	H-3225T	RUBBER LOOP CLAMP, 1-1/2"	1	55	T-050R1600	1/2"ID X 27"LG SOLUTION HOSE	1
27	H-33733	#6 STAR WASHER	2	56	T-050R2700	1/2"ID X 27"LG SOLUTION HOSE	1
28	H-70105	HCS 3/8"- 16 X 1" SS	2	57	T-050R2700	1/2"ID X 27"LG SOLUTION HOSE	1
29	H-70855	NYLOK #6-32 SS	1				

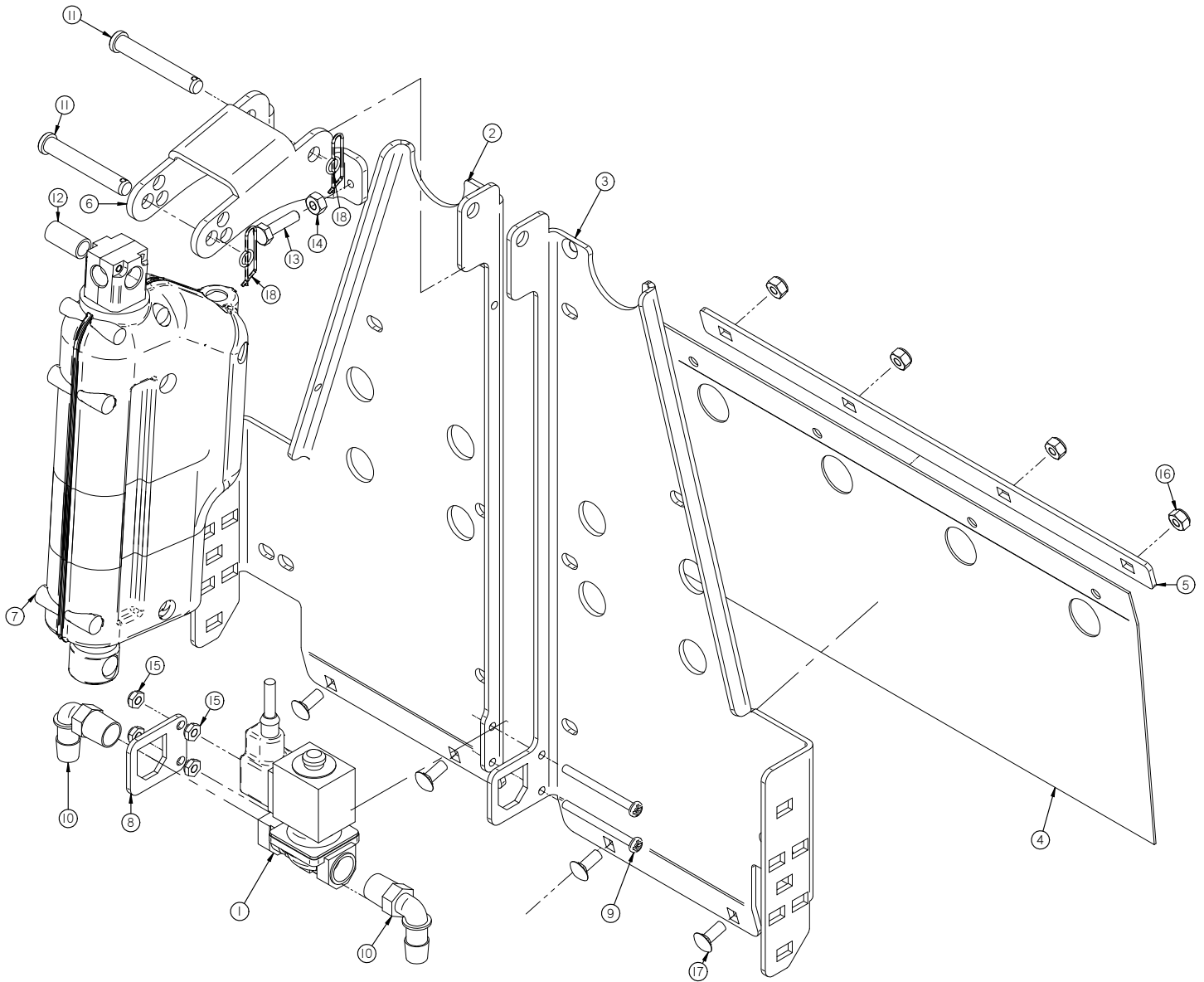

Item	Part No.	Part Description	Qty.
1	170-4500	VALVE	1
2	175-1011L	LEFT LIFT ARM SUPPORT BRACKET	1
3	175-1011R	RIGHT LIFT ARM SUPPORT BRACKET	1
4	175-1015	FRAME CURTAIN	1
5	175-1020	BAND, FRAME CURTAIN	1
6	264-1151	ACTUATOR ARM	1
7	264-2210	4" STROKE 24V ACTUATOR 1000 LB LOAD	1
8	264-5280	VALVE BRACKET	1
9	H-00249	PPH #10-32 X 2 1/4" SS	2
10	H-04763	ELBOW, 90 DEG X 3/8" MNPT X 1/2" BARB, NYLON	2
11	H-15675	CLEVIS PIN, 3/8" X 2-1/2"	2
12	H-63917	SLEEVE, .50 OD X .375 ID X 1.0 LG	1
13	H-70005	HCS 1/4"- 20 X 1" SS	2
14	H-70710	HN 1/4"- 20 SS	2
15	H-70858	NYLOK #10-32 SS	4
16	H-70860	NYLOK 1/4"- 20 SS	4
17	H-74418	CB 1/4"- 20 X 5/8" S/S	4
18	H-RUE14	3/8" RUE RING COTTER	2

Caster Foot Assembly

CASTER
 P/N 190-3035, RED
 P/N 170-3030, GRAY SOFT
 P/N 21-3030, GRAY SOLID

Item	Part No.	Part Description	Qty.
1	175-1380	CASTER FOOT	1
2	370-1247	BUSHING 5/16 X 1/2 X 3/16	2
3	H-0172527	CB 5/16" - 18 X 7/8" SS	8
4	H-70861	NYLOK 5/16" - 18 SS	8
5	H-71015	FW 5/16 ID X 3/4 OD SS	8
6	H-9307K74	GROMMET, 1" ID X 1-3/4" OD BUNA-N	4

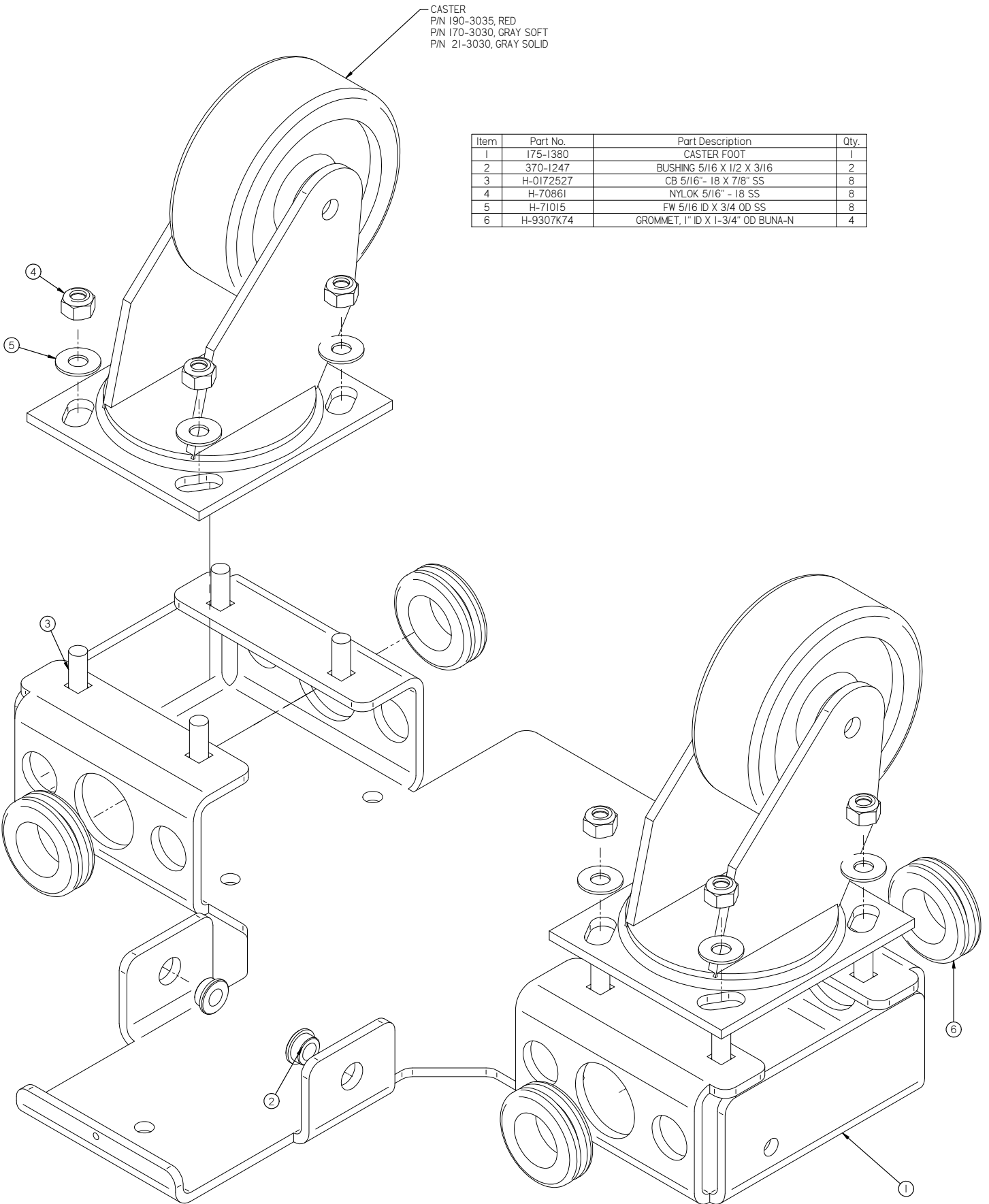

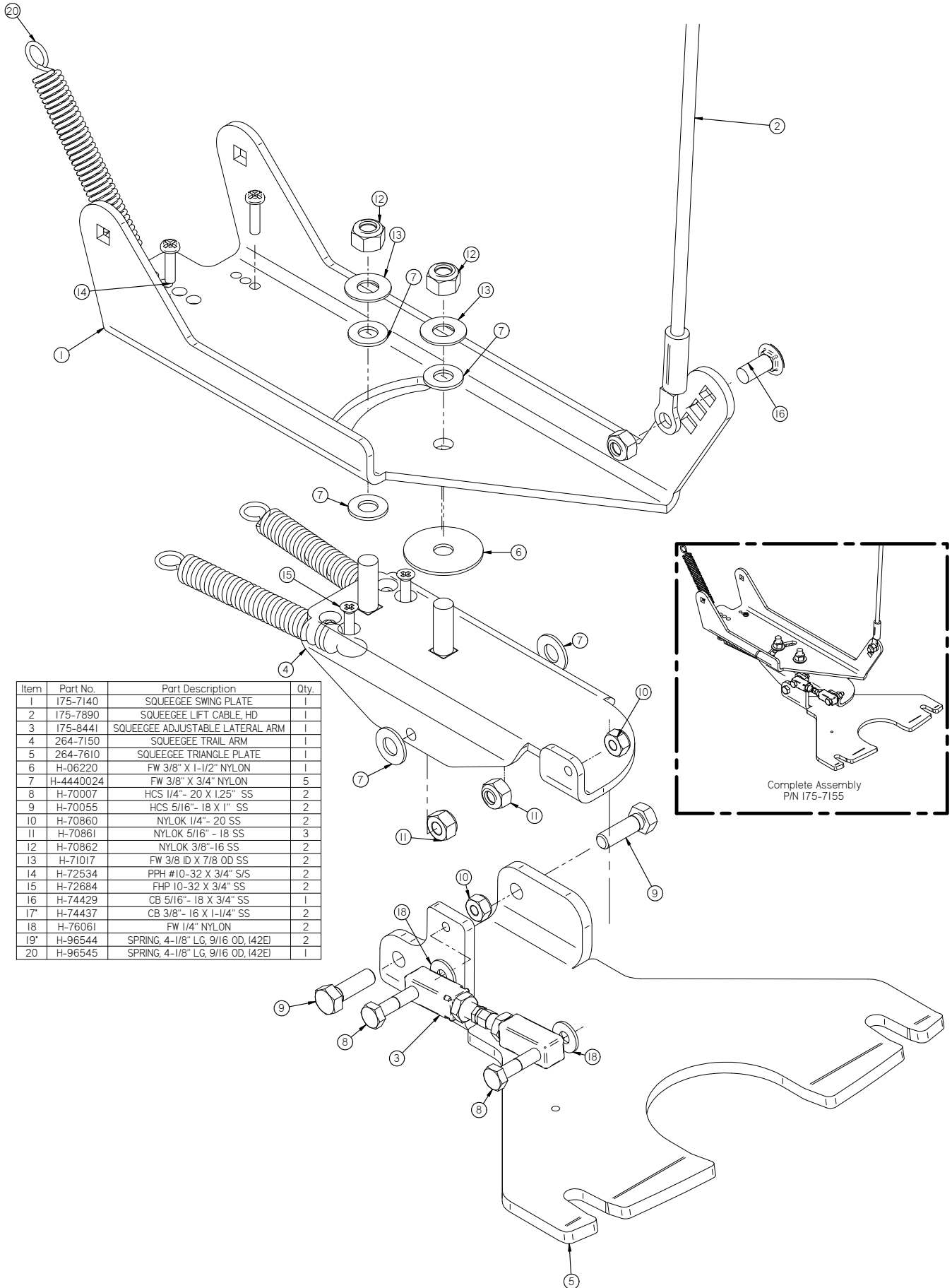

Item	Part No.	Part Description	Qty.
1	175-7140	SQUEEGEE SWING PLATE	1
2	175-7890	SQUEEGEE LIFT CABLE, HD	1
3	175-8441	SQUEEGEE ADJUSTABLE LATERAL ARM	1
4	264-7150	SQUEEGEE TRAIL ARM	1
5	264-7610	SQUEEGEE TRIANGLE PLATE	1
6	H-06220	FW 3/8" X 1-1/2" NYLON	1
7	H-4440024	FW 3/8" X 3/4" NYLON	5
8	H-70007	HCS 1/4" - 20 X 1.25" SS	2
9	H-70055	HCS 5/16" - 18 X 1" SS	2
10	H-70860	NYLOK 1/4" - 20 SS	2
11	H-70861	NYLOK 5/16" - 18 SS	3
12	H-70862	NYLOK 3/8"-16 SS	2
13	H-71017	FW 3/8 ID X 7/8 OD SS	2
14	H-72534	PPH #10-32 X 3/4" S/S	2
15	H-72684	FHP 10-32 X 3/4" SS	2
16	H-74429	CB 5/16" - 18 X 3/4" SS	1
17	H-74437	CB 3/8" - 16 X 1-1/4" SS	2
18	H-76061	FW 1/4" NYLON	2
19	H-96544	SPRING, 4-1/8" LG, 9/16 OD, 142EI	2
20	H-96545	SPRING, 4-1/8" LG, 9/16 OD, 142EI	1

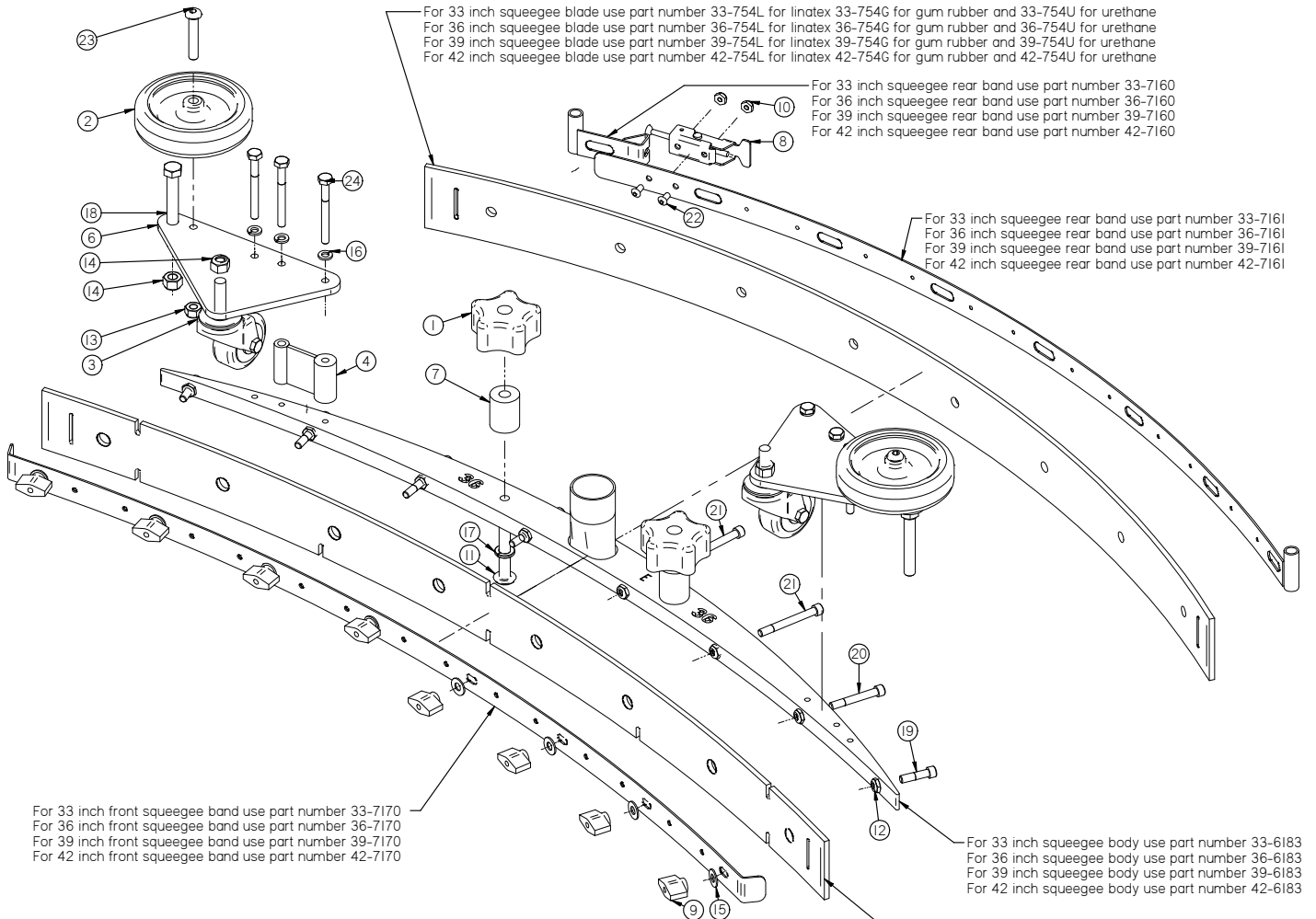

Item	Part No.	Part Description	Qty.	Item	Part No.	Part Description	Qty.
1	150-5786	STAR KNOB, 3/8-16 THREAD	2	13	H-70861	NYLOK 5/16" - 18 SS	2
2	150-7600	4" SIDE WHEEL (GREY)	2	14	H-70862	NYLOK 3/8"-16 SS	4
3	253-7570	CASTER	2	15	H-71013	FW 1/4 ID X 5/8 OD SS	8
4	36-0007	BAND BRACKET HOLDER	2	16	H-71063	LW 1/4" SS	6
5	36-2211	SPACER 1/2 OD X 5/32" LG X.25 ID	6	17	H-71067	LW 3/8" SS	2
6	36-7183	SQUEEGE CASTER BRACKET	2	18	H-71191	HCS 3/8"- 16 X 3" SS	2
7	36-8460	STANDOFF, 1.5"	2	19	H-73462	SHCS 1/4-20 X 1.0 SS	2
8	370-0124	LATCH	1	20	H-73465	SHCS 1/4-20 X 1.75 SS	2
9	5-418A	CLAMPING KNOB	8	21	H-73467	SHCS 1/4-20 X 2.25 SS	4
10	H-0129155	JNYL #10-32, 18-8 S/S	2	22	H-73742	BHSCS 10-32 X 3/8" SS	2
11	H-0171299	BHSCS 3/8"- 16 X 3" SS	2	23	H-73783	BHSCS 5/16-18 X 1.75	2
12	H-37020	JNYL 1/4" - 20	8	24	H-77013	HCS 1/4"- 20 X 2.5" SS	6

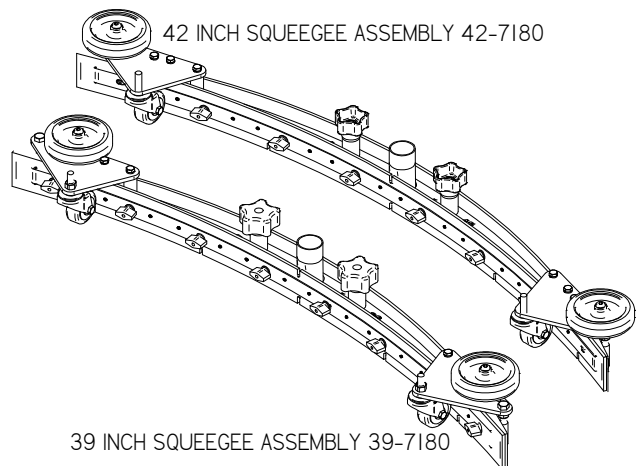
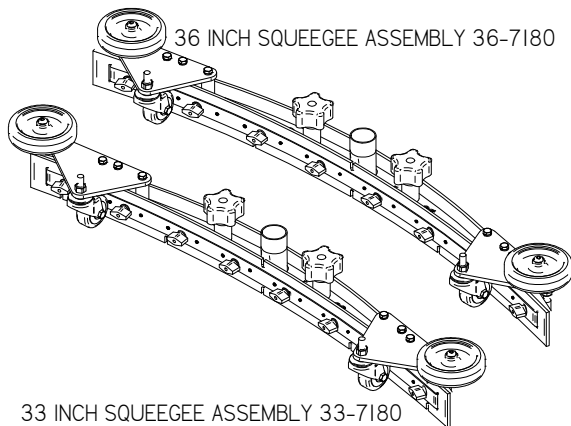

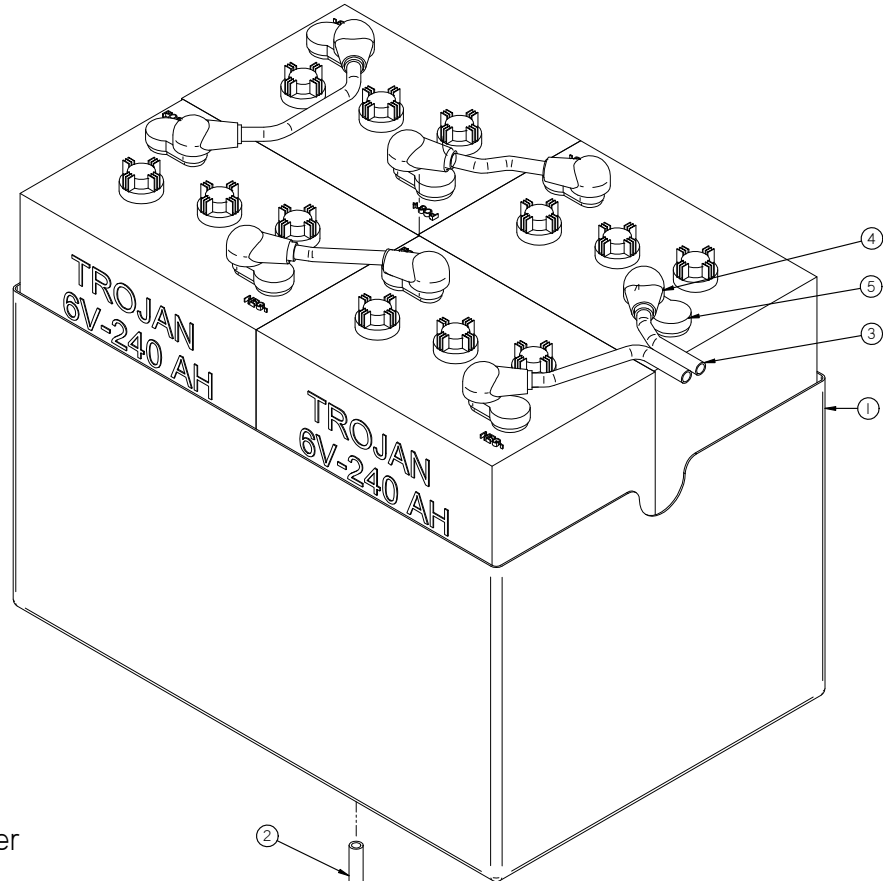

On-Board Charger
(See list below)

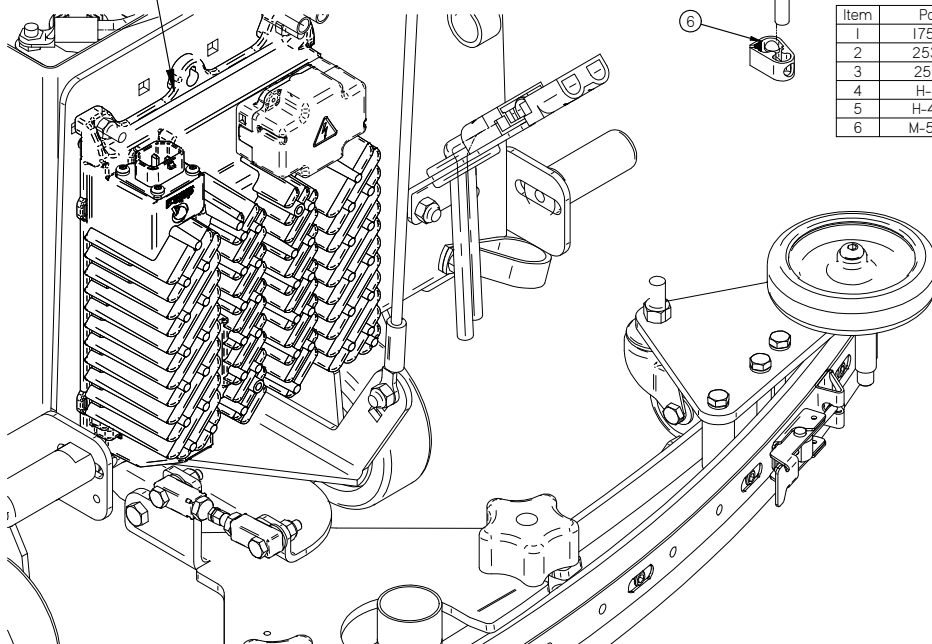

Item	Part No.	Part Description	Qty.
1	175-0000	BATTERY TRAY	1
2	253-1608	BLACK HOSE 3-1/4" LG	1
3	253-1901	WIRE HARNESS, COMPLETE	1
4	H-40031	BATTERY BOOT	8
5	H-400317	TERMINAL COVER	8
6	M-5031K12	CLAMP STYLE PINCH VALVE	1

WHICH BATTERY CHARGER TO USE WITH BATTERY SELECTION

Battery Part Number & Description	Console Charger / North America	Onboard Charger / North America / International
175-2110 (6V / 210AH - WET)	253-2540	175-2460
250-2113 (6V / 240AH - WET)	253-2540	175-2460
250-2120 (6V / 250AH - AGM)	N/A	175-2460

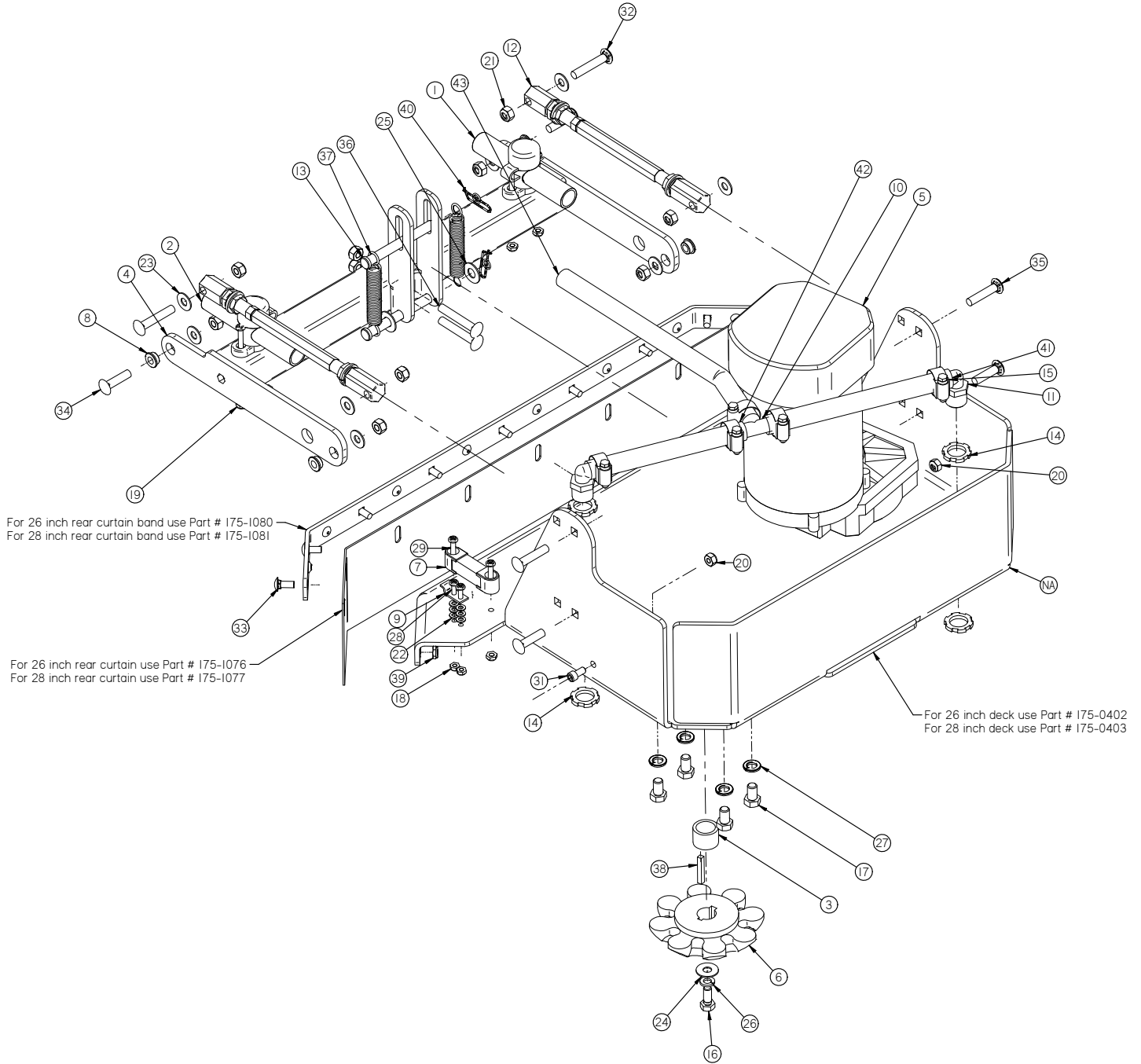

Item	Part No.	Part Description	Qty.	Item	Part No.	Part Description	Qty.
1	175-1012	POS INSULATOR POST (RED)	1	23	H-71015	FW 5/16 ID X 3/4 OD SS	8
2	175-1013	NEG INSULATOR POST (BLACK)	1	24	H-71016	FW 5/16 ID X 7/8 OD SS	2
3	175-5005	DRIVER SPACER	2	25	H-71017	FW 3/8 ID X 7/8 OD SS	2
4	175-9586	SCRUBDECK LIFT ARM, DISK/EDGE	1	26	H-71065	LW 5/16" SS	2
5	253-211	MOTOR, 24V, 3/4 HP, 350 RPM	2	27	H-71067	LW 3/8" SS	8
6	264-5003	BRUSH DRIVER ROUNDED TOOTH	2	28	H-72399	PPH #8-32 X 5/8" S/S	4
7	300-4030	LEVEL	2	29	H-72534	PPH #10-32 X 3/4" S/S	4
8	370-1247	BUSHING 5/16 X 1/2 X 3/16	4	30	H-72556	PPH #10-32 X 2" SS	4
9	4-124	CLIP, LATCH	2	31	H-73459	SHCS 1/4-20 X 1/2 SS	2
10	5-446	1/2" PLASTIC BARB TEE	1	32	H-74401	CB 5/16" - 18 X 1-3/4" SS	2
11	5-447	1/2 NPT X 1/2" BARB ELBOW	2	33	H-74418	CB 1/4" - 20 X 5/8" S/S	9
12	9-25	9.25" ADJUSTABLE LATERAL ARM	2	34	H-74431	CB 5/16" - 18 X 1-1/4" SS	4
13	H-0156758	3/8" X 3-1/2" CLEVIS PIN	2	35	H-74432	CB 5/16" - 18 X 1-1/2" SS	2
14	H-07005	1/2" NPT LOCKNUT	4	36	H-74433	CB 5/16" - 18 X 2" SS	2
15	H-081	CLAMP 1.0" - 1-1/8" SS	5	37	H-96544	SPRING, 4-1/8" LG X 9/16" OD (42E)	2
16	H-70053	HCS 5/16" - 18 X 3/4" SS	2	38	H-K14320	3/16" X 1 1/4" KEY	2
17	H-70140	HCS 3/8" - 24 X 5/8" SS	8	39	H-NJ04C	JNYL 1/4" - 20 SS	9
18	H-70856	NYLOK #8-32 SS	4	40	H-RUE14	3/8" RUE RING COTTER	2
19	H-70858	NYLOK #10-32 SS	8	41	T-050R0800	1/2" ID X 8" LG SOLUTION HOSE	1
20	H-70860	NYLOK 1/4" - 20 SS	2	42	T-050R0800	1/2" ID X 8" LG SOLUTION HOSE	1
21	H-70861	NYLOK 5/16" - 18 SS	10	43	T-050R1300	1/2" ID X 13" LG SOLUTION HOSE	1
22	H-71007	FW #8 SS	12				

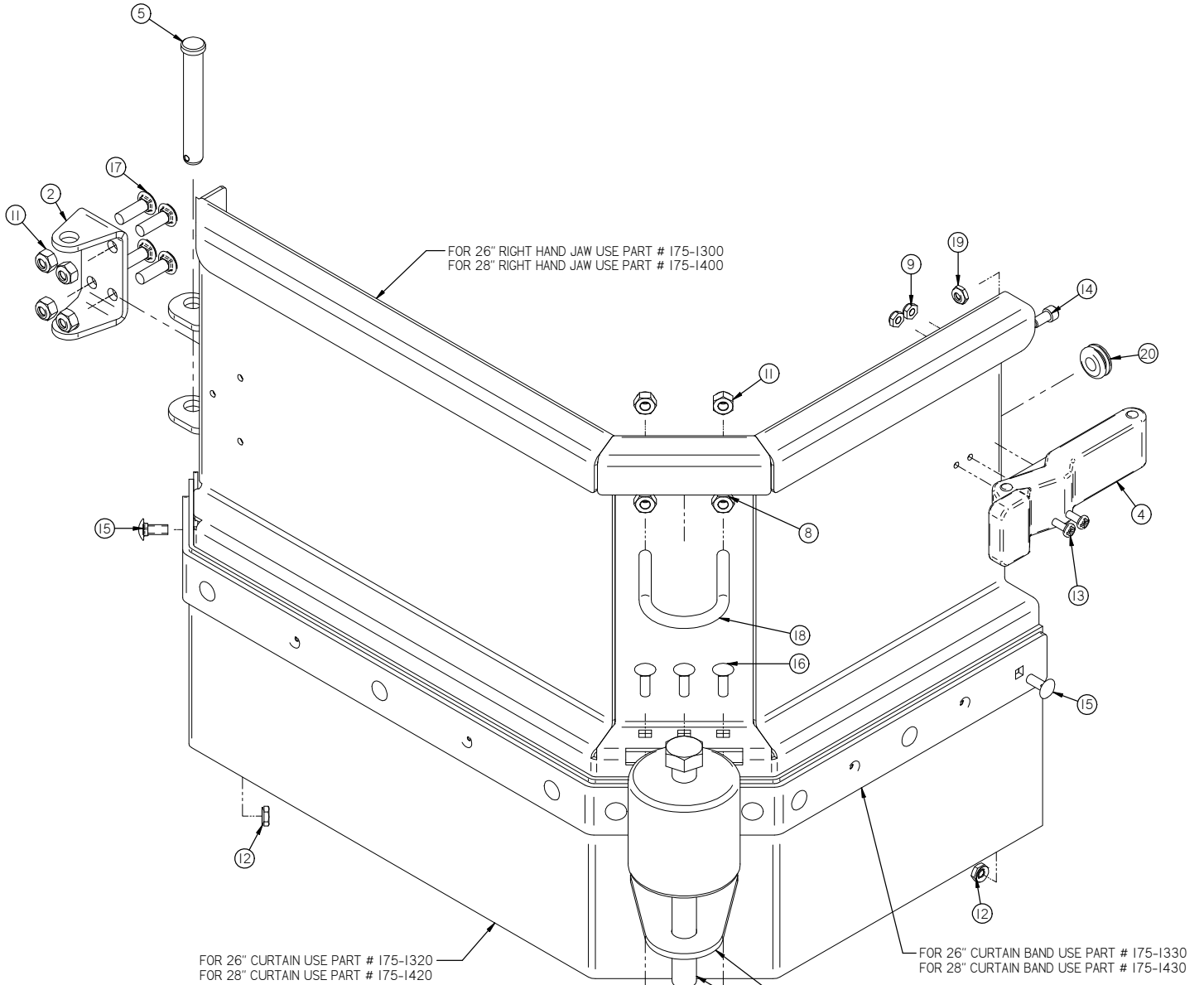

Item	Part No.	Part Description	Qty.
1	175-1128	ROLLER BRACKET	1
2	175-1160	JAW HINGE, INNER	1
3	21-1127	ROLLER	2
4	250-1240	LATCH	1
5	H-0156776	1/2" X 3.5" CLEVIS PIN	1
6	H-13327	HB 5/8" - 11 X 7"	1
7	H-37038	JNYL 5/8" - 11	1
8	H-70711	HN 5/16" - 18 SS	2
9	H-70858	NYLOK #10-32 SS	2
10	H-70860	NYLOK 1/4" - 20 SS	3
11	H-70861	NYLOK 5/16" - 18 SS	6
12	H-70925	KN 1/4-20 S/S	9
13	H-72515	PPH #10-32 X 1/2" S/S	2
14	H-73459	SHCS 1/4-20 X 1/2 SS	1
15	H-74418	CB 1/4" - 20 X 5/8" S/S	9
16	H-74419	CB 1/4" - 20 X .75" SS	3
17	H-74430	CB 5/16" - 18 X 1" SS	4
18	H-74631	5/16-18 X 2 1/4" SS U BOLT	1
19	H-NJ04C	JNYL 1/4" - 20 SS	1
20	M-9307K23	GROMMET .625 DIAMETER HOLE .125 THICK PANEL	1

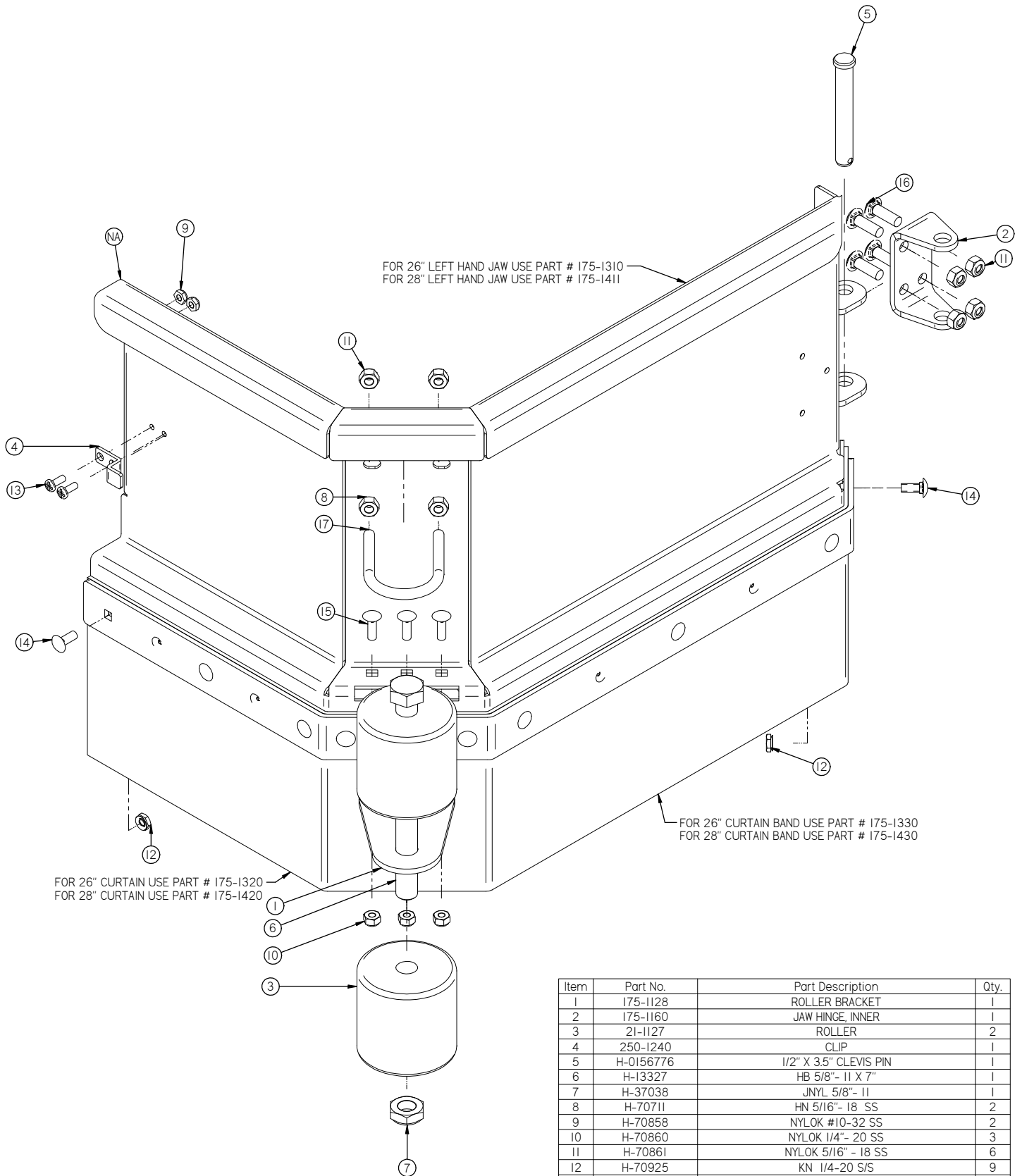

Item	Part No.	Part Description	Qty.
1	175-1128	ROLLER BRACKET	1
2	175-1160	JAW HINGE, INNER	1
3	21-1127	ROLLER	2
4	250-1240	CLIP	1
5	H-0156776	1/2" X 3.5" CLEVIS PIN	1
6	H-13327	HB 5/8" - 11 X 7"	1
7	H-37038	JNYL 5/8" - 11	1
8	H-70711	HN 5/16" - 18 SS	2
9	H-70858	NYLOK #10-32 SS	2
10	H-70860	NYLOK 1/4" - 20 SS	3
11	H-70861	NYLOK 5/16" - 18 SS	6
12	H-70925	KN 1/4-20 S/S	9
13	H-72515	PPH #10-32 X 1/2" S/S	2
14	H-74418	CB 1/4" - 20 X 5/8" S/S	9
15	H-74419	CB 1/4" - 20 X .75" SS	3
16	H-74430	CB 5/16" - 18 X 1" SS	4
17	H-74631	5/16-18 X 2 1/4" SS U BOLT	1

Item	Part No.	Part Description	Qty.
1	150-7601	3" SIDE WHEEL (GREY)	4
2	170-1240	LATCH	2
3	H-70856	NYLOK #8-32 SS	4
4	H-70860	NYLOK 1/4"- 20 SS	12
5	H-70861	NYLOK 5/16" - 18 SS	4
6	H-71015	FW 5/16 ID X 3/4 OD SS	4
7	H-72641	FHP #8-32 X 3/8" SS	4
8	H-74401	CB 5/16"- 18 X 1-3/4" SS	4
9	H-74418	CB 1/4"- 20 X 5/8" S/S	12
10	M-9307K23	GROMMET .625 DIAMETER HOLE .125 THICK PANEL	6

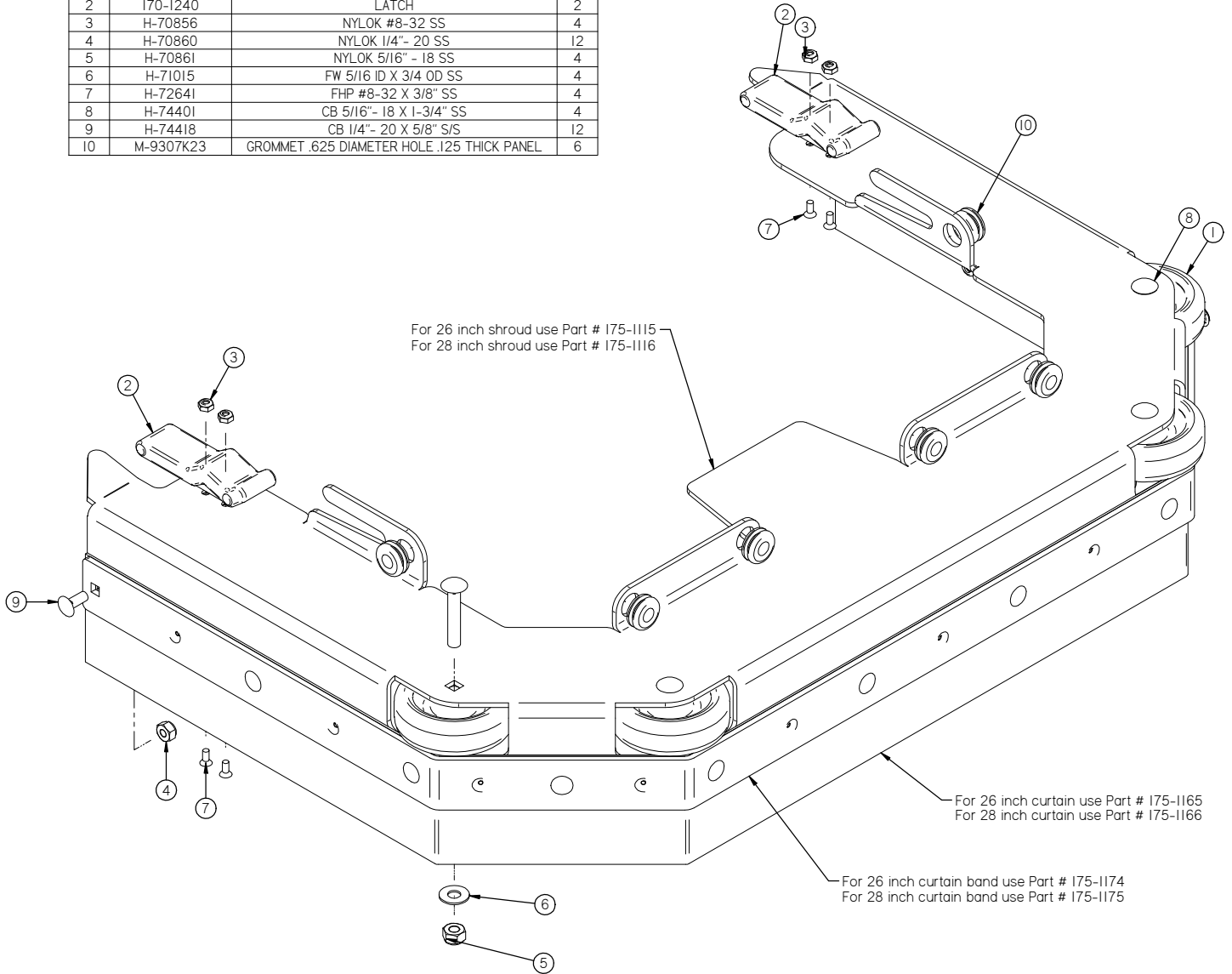

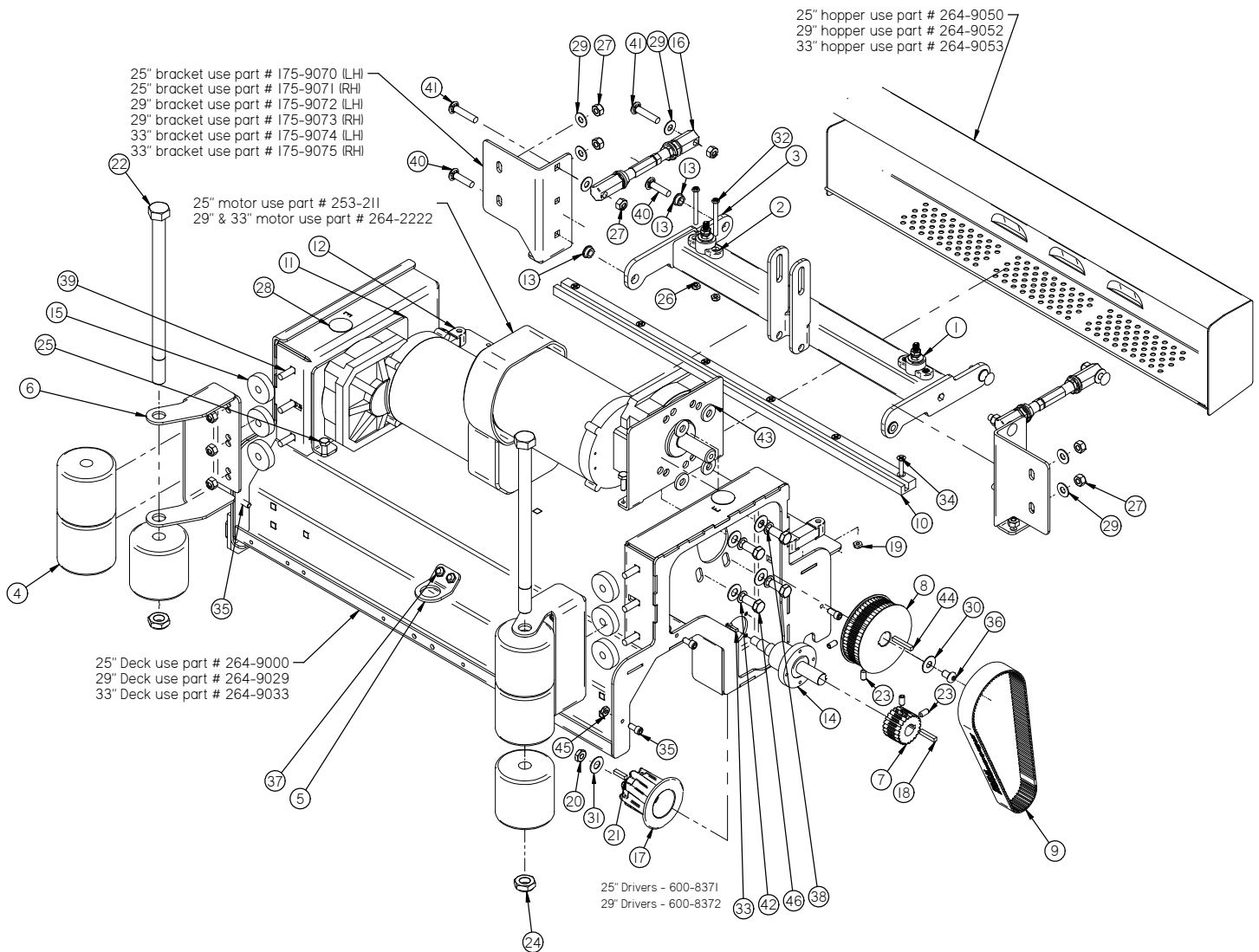

Item	Part No.	Part Description	Qty.	Item	Part No.	Part Description	Qty.
1	175-2700	NEG INSULATOR POST (BLACK)	1	25	H-70003	HCS 1/4"-20 X 3/4" SS	4
2	175-2710	POS INSULATOR POST (RED)	1	26	H-70858	NYLOK #10-32 SS	4
3	175-9590	SCRUBDECK LIFT ARM, CYLINDRICAL	1	27	H-70861	NYLOK 5/16" - 18 SS	22
4	21-1127	ROLLER	6	28	H-70889	HOLE PLUG 7/8"	2
5	253-9003	QUICK DISCONNECT BRACKET	1	29	H-71015	FW 5/16 ID X 3/4 OD SS	12
6	264-1129	ROLLER BRACKET	2	30	H-71016	FW 5/16 ID X 7/8 OD SS	2
7	264-8215	TIMING SPROCKET 26 TOOTH	2	31	H-71017	FW 3/8 ID X 7/8 OD SS	10
8	264-8225	TIMING SPROCKET 56 TOOTH	2	32	H-72556	PPH #10-32 X 2" SS	4
9	264-8230	565-5M-25 HI-PERFORMANCE PD PLUS BELT	2	33	H-72682	FHP #10-32 X 1/2" SS	8
10	264-8325	HOPPER RAIL 25"	1	34	H-72685	FHP 10-32 X 1" SS	6
11	264-9002	MOTOR ADJ BRACKET	2	35	H-73459	SHCS 1/4"-20 X 1/2 SS	6
12	300-4030	LEVEL	2	36	H-73777	BHSCS 5/16-18 X 1/2"	2
13	370-1247	BUSHING 5/16 X 1/2 X 3/16	4	37	H-74417	CB 1/4"- 20 X .5" SS	2
14	370-8240A	BEARING HOUSING/BEARING	2	38	H-74429	CB 5/16"- 18 X 3/4" SS	8
15	4-446	GROMMET-3/8 ID X 1-1/2 OD X .375	6	39	H-74430	CB 5/16"- 18 X 1" SS	6
16	6-25	6.25"ADJUSTABLE LATERAL ARM	2	40	H-74431	CB 5/16"- 18 X 1-1/4" SS	4
17	600-8371	SPIRAL CYLINDRICAL DRIVER	2	41	H-74432	CB 5/16"- 18 X 1-1/2" SS	4
18	H-01125	3/16" X 1" KEY	2	42	H-90895	WASHER, SERRATED BELLEVILLE, 3/8", S/S	8
19	H-0129155	JNYL #10-32, 18-8 S/S	6	43	H-98025	FW 3/8" GRADE 8	8
20	H-0171004	JNYL 3/8- 24 SS	2	44	H-K14320	3/16" X 1 1/4" KEY	2
21	H-0953152	3/16" X 3/4" KEY	2	45	H-NJ04C	JNYL 1/4" - 20 SS	7
22	H-11333	HB 5/8"- 11 X 10"	2	46	M-92865A214	HCS 3/8"-24 X 7/8" SS	8
23	H-25382	SETScrew, KCP, 1/4"-20 X 1/2"	8				
24	H-37038	JNYL 5/8"- 11	2				

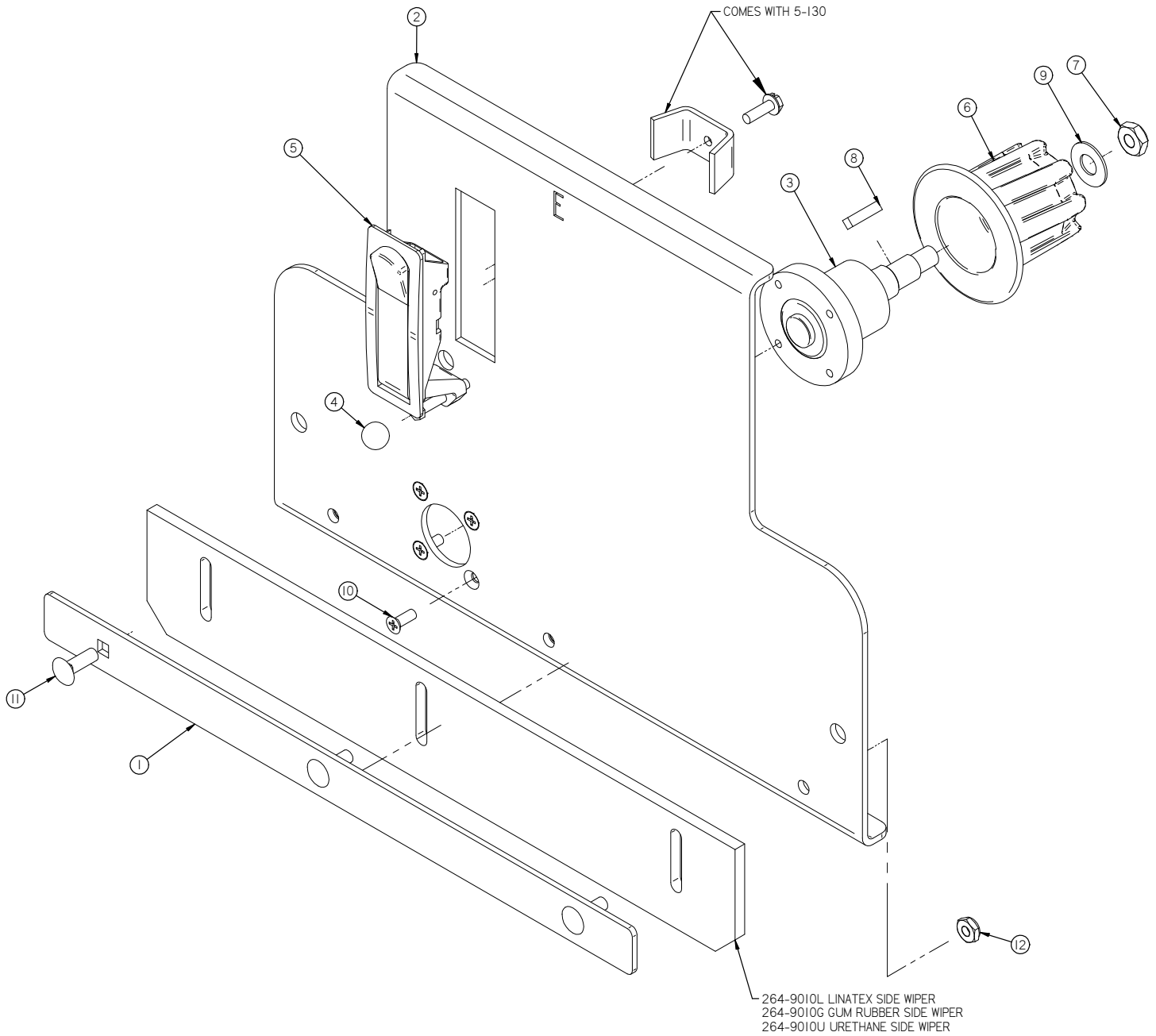

Item	Part No.	Part Description	Qty.
1	264-9015	WIPER BAND	1
2	264-9022	DRIVE COVER	1
3	370-8241A	IDLER DRIVE BEARING	1
4	5-100	GROMMET	1
5	5-130	DOOR LATCH	1
6	600-8371	CYLINDRICAL DRIVER (HARDCOAT)	1
7	H-0171004	JNYL 3/8" - 24 SS	1
8	H-0953152	3/16" X 3/4" KEY	1
9	H-71017	FW 3/8 ID X 7/8 OD SS	1
10	H-72682	FHP #10-32 X 1/2" SS	4
11	H-74419	CB 1/4" - 20 X .75" SS	3
12	H-NJ04C	JNYL 1/4" - 20 SS	3

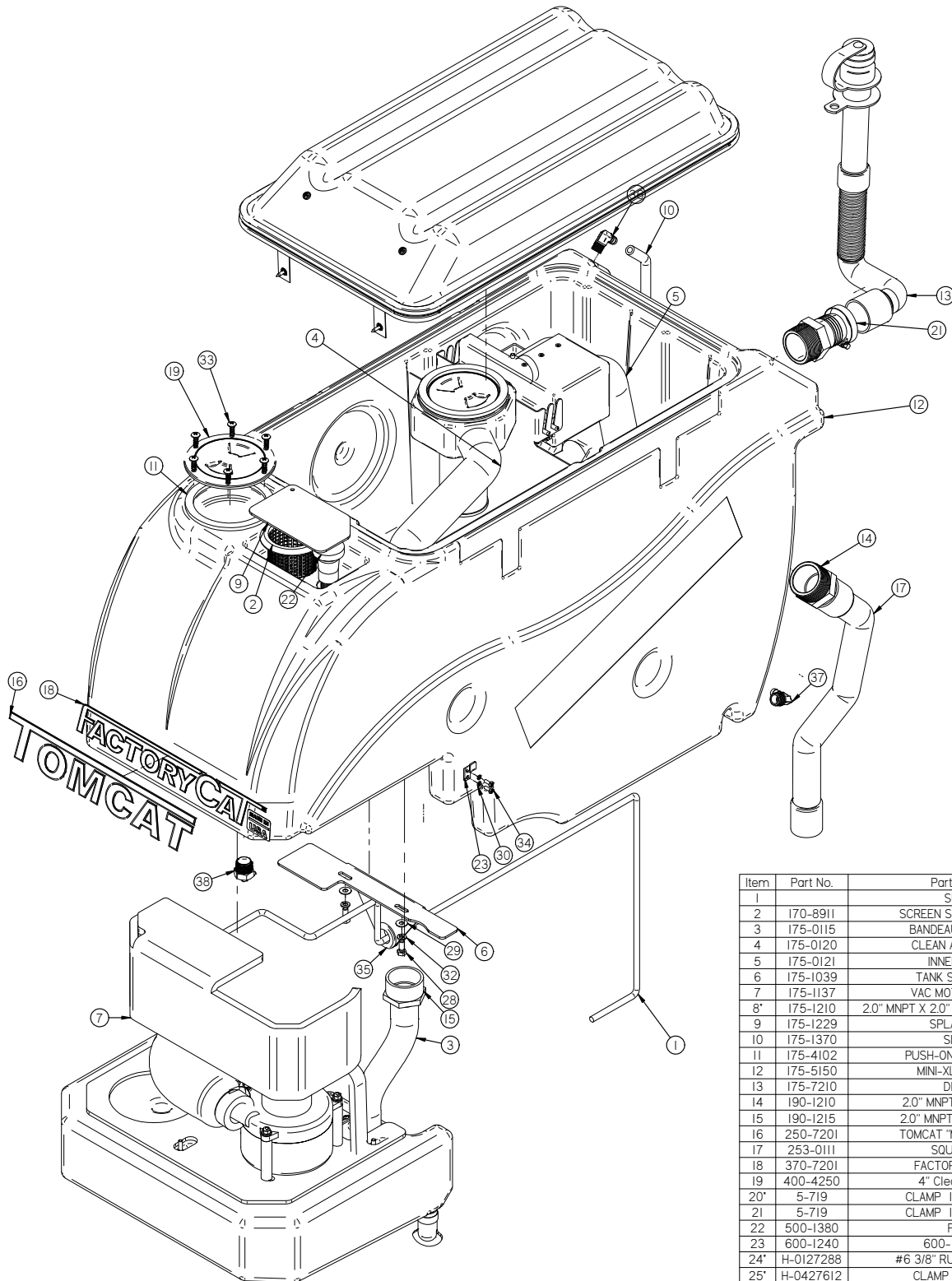

Item	Part No.	Part Description	Qty.
1		SUDS HOSE	1
2	170-8911	SCREEN STRAINER, 4-1/4" LG	1
3	175-0115	BANDEAU TO TANK HOSE	1
4	175-0120	CLEAN AIR INTAKE HOSE	1
5	175-0121	INNER TANK HOSE	1
6	175-1039	TANK STRAP BRACKET	1
7	175-1137	VAC MOTOR INSULATION	1
8	175-1210	2.0" MNPT X 2.0" BARB, PVC CHAMFERED ID	1
9	175-1229	SPLASH CURTAIN	1
10	175-1370	SIGHT TUBE	1
11	175-4102	PUSH-ON RUBBER GASKET	1
12	175-5150	MINI-XLSOL/REC TANK	1
13	175-7210	DRAIN HOSE	1
14	190-1210	2.0" MNPT X 2.0" BARB, PVC	3
15	190-1215	2.0" MNPT X 1.50" BARB, PVC	1
16	250-7201	TOMCAT "MOLD ON" GRAPHIC	1
17	253-0111	SQUEEGEE HOSE	1
18	370-7201	FACTORY CAT STICKER	1
19	400-4250	4" Clear Access Port	1
20	5-719	CLAMP 1 9/16 - 2 1/2" SS	1
21	5-719	CLAMP 1 9/16 - 2 1/2" SS	1
22	500-1380	FILL HOSE	1
23	600-1240	600-1240 clippsm	2
24	H-0127288	#6 3/8" RUBBER LOOP CLAMP	1
25	H-0427612	CLAMP 3/4"- 1-3/4" SS	2
26	H-3225T	RUBBER LOOP CLAMP, 1-1/2"	1
27	H-70001	HCS 1/4"-20 X 1/2" SS"	2
28	H-70053	HCS 5/16"- 18 X 3/4" SS	2
29	H-71015	FW 5/16 ID X 3/4 OD SS	2
30	H-71059	LW #10, SS	4
31	H-71063	LW 1/4" SS	2
32	H-71065	LW 5/16" SS	2
33	H-71894	#14 X 1" SELF TAPPING SCREW	6
34	H-72515	PPH #10-32 X 1/2" S/S	4
35	H-9307K74	GROMMET, 1" ID X 1-3/4" OD BUNA-N	1
36	M-53525K21	ELBOW, 3/8" MNPT X 1/2" BARB, BRASS	1
37	M-53525K58	ELBOW, 1/2" MNPT X 1/2" BARB, BRASS	2
38	M-5463K496	.75 NPT X .25 BARBED X 90 DEG.par	1
39	M-5463K727	WYE, 1/2", NYLON	1

Item	Part No.	Part Description	Qty.
1	175-4102	GASKET, BAFFLE CAP	1
2	175-1029	TANK BACK SPLASH	1
3	175-1133	INNER VAC BOX	1
4	175-1134	MINIMAG BAFFLE	1
5	175-1135	DRAIN SAVER BASKET ROD	2
6	175-4080	STRAINER TOP	1
7	175-4103	BALL FLOAT GASKET	1
8	264-4086	VAC BOX FILTER	1
9	264-8912	DRAIN SAVER BASKET	1
10	264-9111	SCREEN STRAINER	1
11	38-712	OVERFILL SHUTOFF BALL	1
12	38-738	STRAINER GASKET	1
13	400-4250	4" Clear Access Port	1
14	H-70858	NYLOK #10-32 SS	5
15	H-70923	KN #10-32 SS	2
16	H-71010	FW #10 ID X 11/16 OD SS	3
17	H-71894	#14 X 1" SELF TAPPING SCREW	4
18	H-72554	PPH #10-32 X 1-1/2"	2
19	H-72682	FHP #10-32 X 1/2" SS	3
20	H-72684	FHP 10-32 X 3/4" SS	2
21	H-72914	PPH SMS #8 X 1/2"	6
22	M-9452K132	.0625 X 3.50 O43 O-RING	1

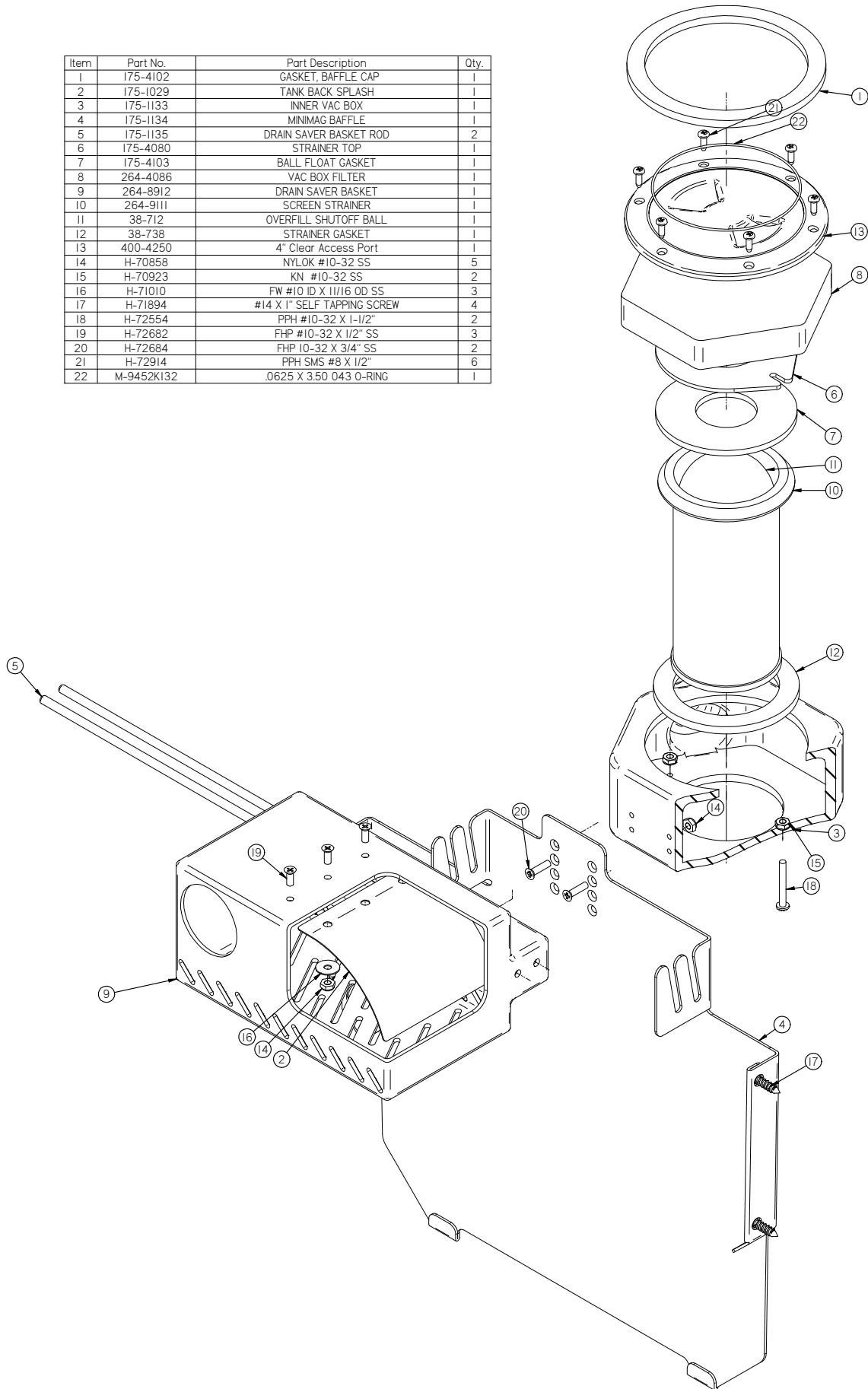

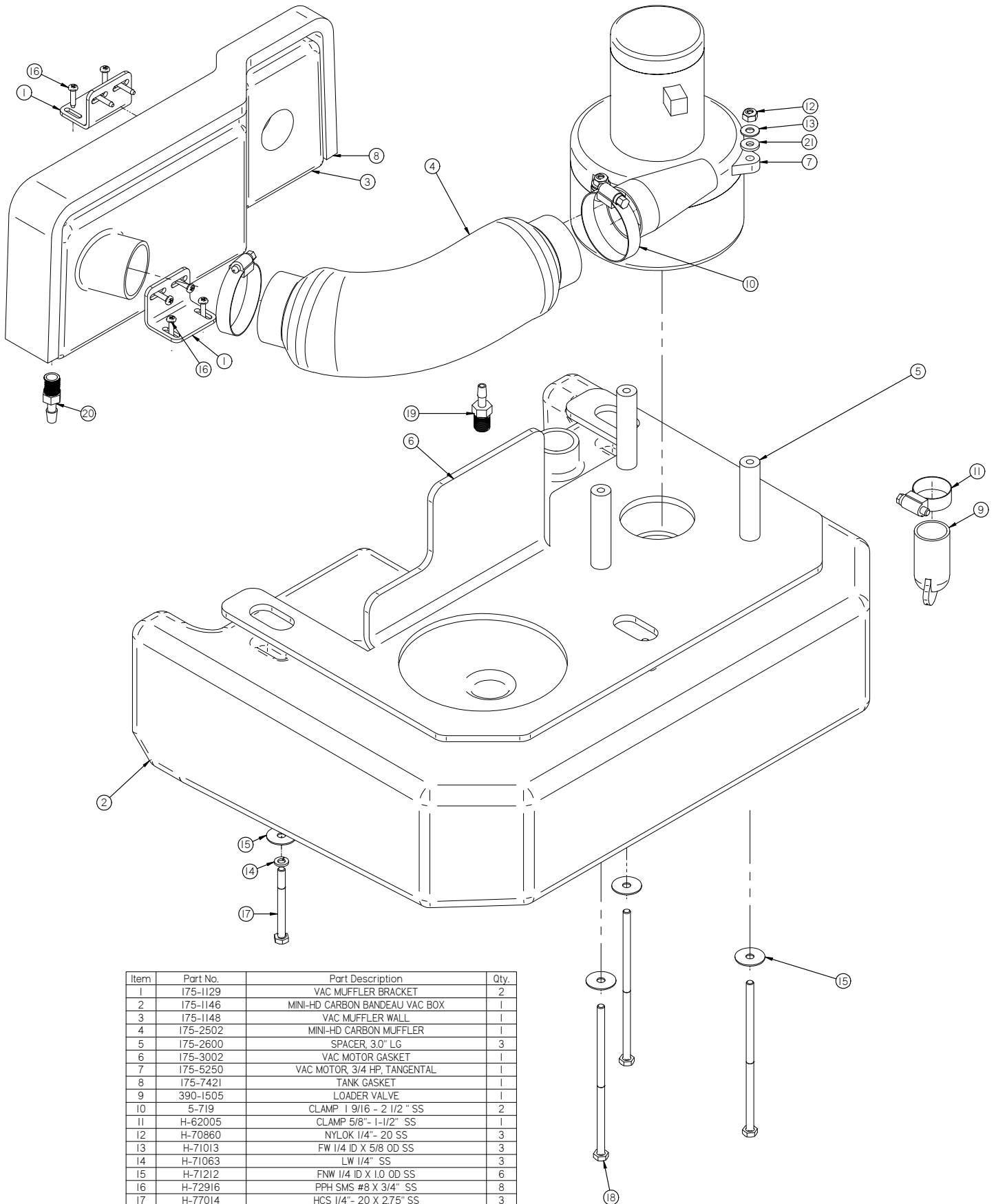

Item	Part No.	Part Description	Qty.
1	175-1129	VAC MUFLER BRACKET	2
2	175-1146	MINI-HD CARBON BANDEAU VAC BOX	1
3	175-1148	VAC MUFLER WALL	1
4	175-2502	MINI-HD CARBON MUFLER	1
5	175-2600	SPACER, 3.0" LG	3
6	175-3002	VAC MOTOR GASKET	1
7	175-5250	VAC MOTOR, 3/4 HP, TANGENTIAL	1
8	175-7421	TANK GASKET	1
9	390-1505	LOADER VALVE	1
10	5-719	CLAMP 1 9/16 - 2 1/2" SS	2
11	H-62005	CLAMP 5/8"- 1-1/2" SS	1
12	H-70860	NYLOK 1/4"- 20 SS	3
13	H-71013	FW 1/4 ID X 5/8 OD SS	3
14	H-71063	LW 1/4" SS	3
15	H-71212	FNW 1/4 ID X 1.0 OD SS	6
16	H-72916	PPH SMS #8 X 3/4" SS	8
17	H-77014	HCS 1/4"- 20 X 2.75" SS	3
18	H-77025	HCS 1/4"- 20 X 6.0" SS	3
19	M-5463K439	.25 NPT X .125 BARB	1
20	M-5463K445	.25 NPT X .25 BARB	1
21	M-90130A029	.25" NEOPRENE WASHER	3

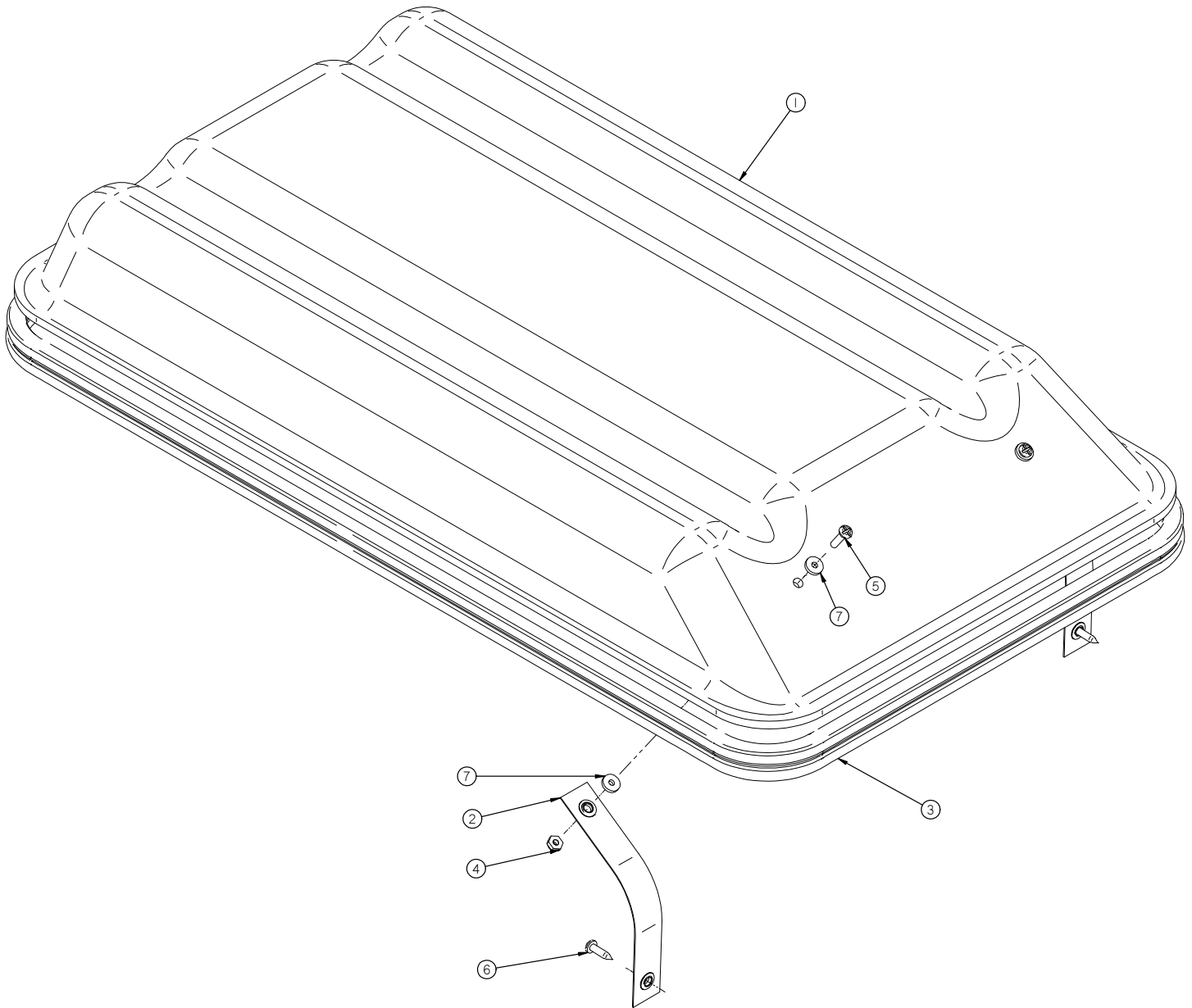

Item	Part No.	Part Description	Qty.
1	175-1409	MINI-HD CARBON CLEAR LID	1
2	175-1412	TANK LID STRAP W/GROMMETS	2
3	175-4101	PUSH-ON RUBBER GASKET	1
4	H-0129155	JNYL #10-32, 18-8 S/S	2
5	H-72534	PPH #10-32 X 3/4" S/S	2
6	H-72916	PPH SMS #8 X 3/4" SS	2
7	H-90133	.170 ID X .50 OD X .093 TH NEOPRENE WASHER	4

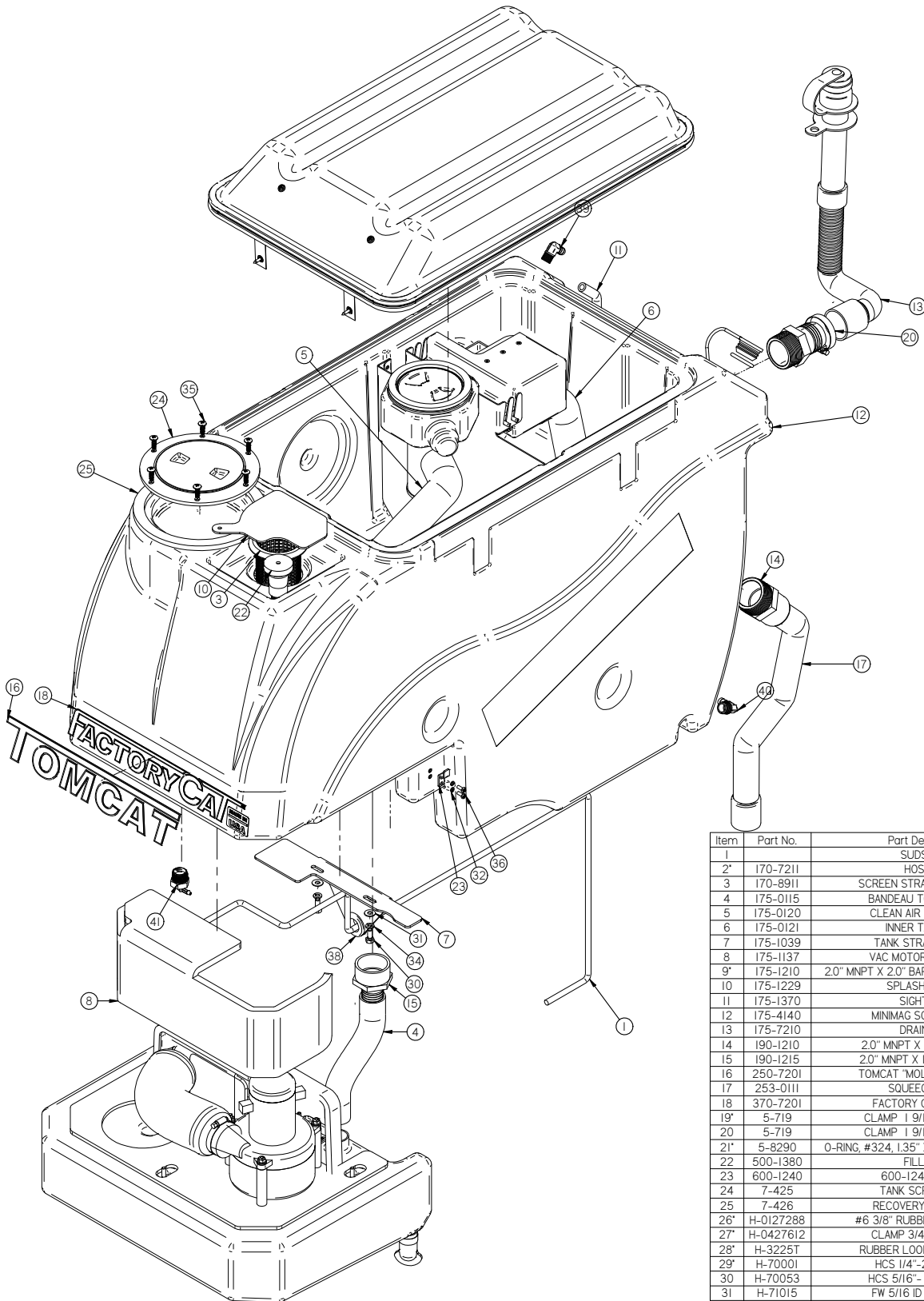

Item	Part No.	Part Description	Qty.
1		SUDS HOSE	1
2	170-7211	HOSE CAP	1
3	170-8911	SCREEN STRAINER, 4-1/4" LG	1
4	175-0115	BANDEAU TO TANK HOSE	1
5	175-0120	CLEAN AIR INTAKE HOSE	1
6	175-0121	INNER TANK HOSE	1
7	175-1039	TANK STRAP BRACKET	1
8	175-1137	VAC MOTOR INSULATION	1
9	175-1210	2.0" MNPT X 2.0" BARB, PVC CHAMFERED ID	1
10	175-1229	SPLASH CURTAIN	1
11	175-1370	SIGHT TUBE	1
12	175-4140	MINIMAG SOL/REC TANK	1
13	175-7210	DRAIN HOSE	1
14	190-1210	2.0" MNPT X 2.0" BARB, PVC	3
15	190-1215	2.0" MNPT X 1.50" BARB, PVC	1
16	250-7201	TOMCAT "MOLD ON" GRAPHIC	1
17	253-0111	SQUEEGEE HOSE	1
18	370-7201	FACTORYCAT STICKER	1
19	5-719	CLAMP 1 9/16 - 2 1/2" SS	1
20	5-719	CLAMP 1 9/16 - 2 1/2" SS	1
21	5-8290	O-RING, #324, 1.35" X 1.77" X .210" BUNA-N	1
22	500-1380	FILL HOSE	1
23	600-1240	600-1240 clippsm	2
24	7-425	TANK SCREW ON LID	1
25	7-426	RECOVERY LID GASKET	1
26	H-0127288	#6 3/8" RUBBER LOOP CLAMP	1
27	H-0427612	CLAMP 3/4" - 1-3/4" SS	2
28	H-3225T	RUBBER LOOP CLAMP, 1-1/2"	1
29	H-70001	HCS 1/4"-20 X 1/2" SS"	2
30	H-70053	HCS 5/16"- 18 X 3/4" SS	2
31	H-71015	FW 5/16 ID X 3/4 OD SS	2
32	H-71059	LW #10, SS	4
33	H-71063	LW 1/4" SS	2
34	H-71065	LW 5/16" SS	2
35	H-71894	#14 X 1" SELF TAPPING SCREW	8
36	H-72615	PPH #10-32 X 1/2" S/S	4
37	H-72916	PPH SMS #8 X 3/4" SS	2
38	H-9307K74	GROMMET, 1" ID X 1-3/4" OD BUNA-N	1
39	M-53525K21	ELBOW, 3/8" MNPT X 1/2" BARB, BRASS	1
40	M-53525K58	ELBOW, 1/2" MNPT X 1/2" BARB, BRASS	2
41	M-5463K496	.75 NPT X .25 BARBED X 90 DEG.par	1
42	M-5463K727	WYE, 1/2", NYLON	1

Item	Part No.	Part Description	Qty.
1	175-4102	GASKET, BAFFLE CAP	1
2	175-1029	TANK BACK SPLASH	1
3	175-1133	INNER VAC BOX	1
4	175-1134	MINIMAG BAFFLE	1
5	175-1135	DRAIN SAVER BASKET ROD	2
6	175-4080	STRAINER TOP	1
7	175-4103	BALL FLOAT GASKET	1
8	264-4086	VAC BOX FILTER	1
9	264-8912	DRAIN SAVER BASKET	1
10	264-9111	SCREEN STRAINER	1
11	38-712	OVERFILL SHUTOFF BALL	1
12	38-738	STRAINER GASKET	1
13	400-4250	4" Clear Access Port	1
14	H-70858	NYLOK #10-32 SS	5
15	H-70923	KN #10-32 SS	2
16	H-71010	FW #10 ID X 11/16 OD SS	3
17	H-71894	#14 X 1" SELF TAPPING SCREW	4
18	H-72554	PPH #10-32 X 1-1/2"	2
19	H-72682	FHP #10-32 X 1/2" SS	3
20	H-72684	FHP 10-32 X 3/4" SS	2
21	H-72914	PPH SMS #8 X 1/2"	6
22	M-9452K132	.0625 X 3.50 O43 O-RING	1

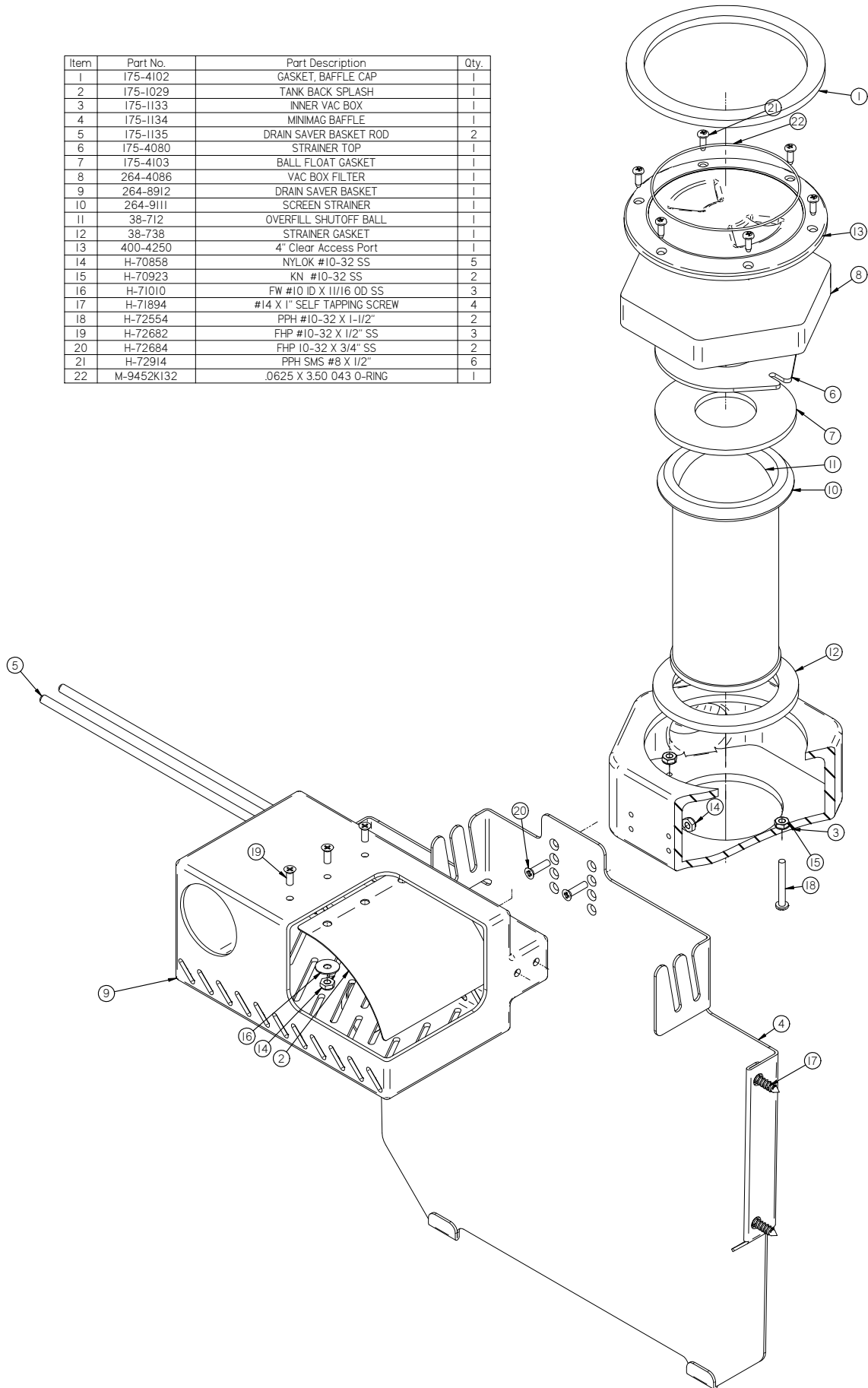

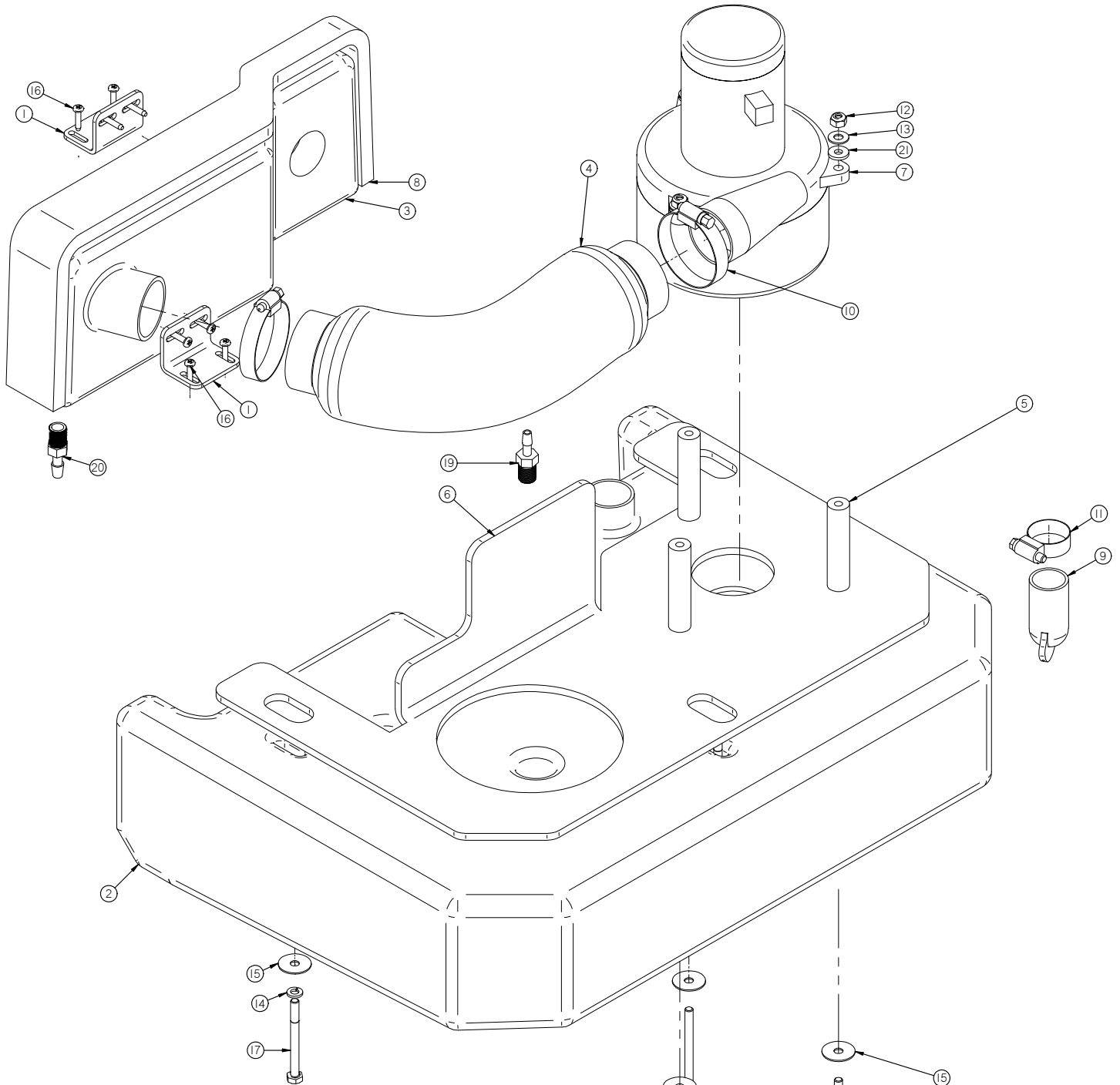

Item	Part No.	Part Description	Qty.
1	175-1129	VAC MUFLER BRACKET	2
2	175-1147	BANDEAU VAC BOX	1
3	175-1148	VAC MUFLER WALL	1
4	175-2502	MINI-XL MUFLER	1
5	175-2600	SPACER, 3.0" LG	3
6	175-3002	VAC MOTOR GASKET	1
7	175-5250	VAC MOTOR, 3/4 HP, TANGENTIAL	1
8	175-7421	TANK GASKET	1
9	390-1505	LOADER VALVE	1
10	5-719	CLAMP 1 9/16 - 2 1/2" SS	2
11	H-62005	CLAMP 5/8"- 1-1/2" SS	1
12	H-70860	NYLOK 1/4"- 20 SS	3
13	H-71013	FW 1/4 ID X 5/8 OD SS	3
14	H-71063	LW 1/4" SS	3
15	H-71212	FNW 1/4 ID X 1.0 OD SS	6
16	H-72916	PPH SMS #8 X 3/4" SS	8
17	H-77014	HCS 1/4"- 20 X 2.75" SS	3
18	H-77025	HCS 1/4"- 20 X 6.0" SS	3
19	M-5463K439	.25 NPT X .125 BARB	1
20	M-5463K445	.25 NPT X .25 BARB	1
21	M-90130A029	.25" NEOPRENE WASHER	3

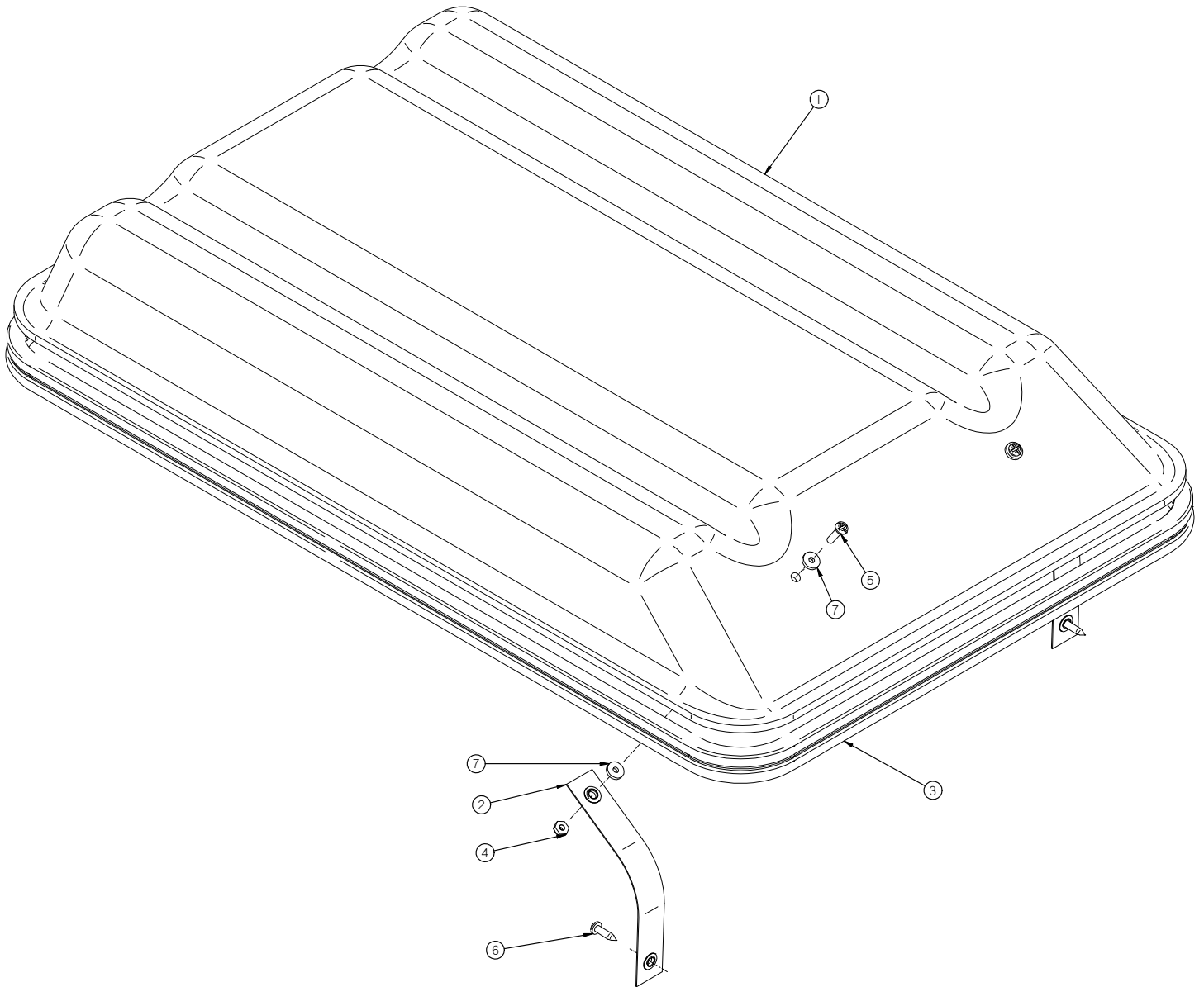

Item	Part No.	Part Description	Qty.
1	I75-1410	VAC FORMED SMOKED COVER	1
2	I75-1412	TANK LID STRAP W/GROMMETS	2
3	I75-4101	PUSH-ON RUBBER GASKET	1
4	H-0129155	JNYL #10-32, 18-8 S/S	2
5	H-72534	PPH #10-32 X 3/4" S/S	2
6	H-72916	PPH SMS #8 X 3/4" SS	2
7	H-90133	.170 ID X .50 OD X .093 TH NEOPRENE WASHER	4

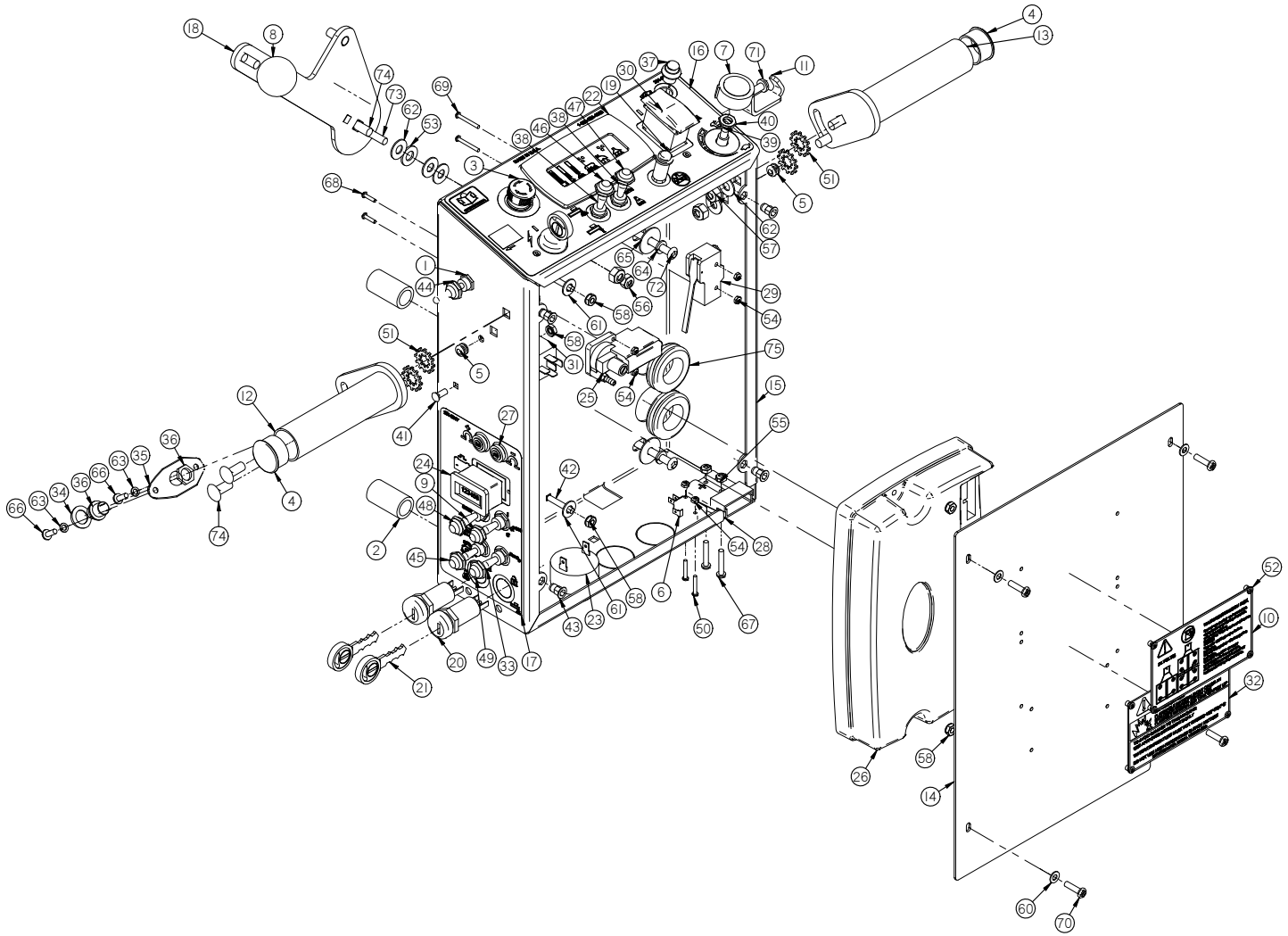

Item	Part No.	Part Description	Qty.	Item	Part No.	Part Description	Qty.
1	150-2830	SWITCH, TOGGLE, MOM/OFF/MOM (DPDT)	1	39	7-292	5K POTENTIOMETER	1
2	170-2700	SPACER, 1-1/2" LG	4	40	H-0147994	3/8-32 X 1/2" PANEL NUT	1
3	175-0300	Emergency stop switch, 51 series, IC/O	1	41	H-0172518	CB #10-32 X 1/2" SS	1
4	190-1390	END CAP	2	42	H-0172522	CB #10-32 X 1-1/4" SS	2
5	21-2203	GROMMET, RUBBER 3/16 ID X 13/32 OD X 3/32 TH.	2	43	H-1032HCN	HCN #10-32	4
6	21-2230	MICRO SWITCH	1	44	H-11196	PROTECTIVE BOOT, TOGGLE SWITCH, (RED)	1
7	21-4520	SPEED CONTROL KNOB, RED	1	45	H-11198	PROTECTIVE BOOT, TOGGLE SWITCH, (GREEN)	1
8	21-7101	LIFT KNOB	1	46	H-11199	PROTECTIVE BOOT, TOGGLE SWITCH, (BLUE)	2
9	253-283	SWITCH, TOGGLE, ON/OFF/ON (DPDT)	1	47	H-11200	PROTECTIVE BOOT, TOGGLE SWITCH, (BLACK)	1
10	253-7280	EXPLOSION WARNING PLATE	1	48	H-11201	PROTECTIVE BOOT, TOGGLE SWITCH, (GRAY)	1
11	253-9491	HOOK	1	49	H-11205	PROTECTIVE BOOT, TOGGLE SWITCH, (LIGHT BLUE)	1
12	264-1290	ADJUSTABLE HANDLE BAR, LEFT	1	50	H-28667	PHP MS 4-40 X 3/4"	2
13	264-1291	ADJUSTABLE HANDLE BAR, RIGHT	1	51	H-33761	5/16" INT/EXT STAR WASHER	4
14	264-2001	CONTROL PANEL COVER	1	52	H-41007	AB4-3A BLIND RIVET	12
15	264-2012	CONTROL PANEL BOX TRACTION	1	53	H-4440024	FW 3/8" X 3/4" NYLON	1
16	264-2016	MINI MAG TD CONTROL PANEL STICKER	1	54	H-70854	NYLOK #4-40 SS	6
17	264-2017	SUDS/SPRAY STICKER	1	55	H-70856	NYLOK #8-32 SS	2
18	264-7100	SQUEEGEE LIFT LEVER	1	56	H-70860	NYLOK 1/4"- 20 SS	1
19	290-2310	FULL RECOVERY (RED)	1	57	H-70861	NYLOK 5/16" - 18 SS	5
20	290-234	KEY SWITCH (WITH KEY)	3	58	H-70923	KN #10-32 SS	5
21	290-234A	KEY SET (REPLACE)	3	59	H-70925	KN 1/4-20 S/S	1
22	290-2891	LCD SCREEN	1	60	H-71009	FW #10 SS	4
23	370-2920	ALARM	1	61	H-71013	FW 1/4 ID X 5/8 OD SS	2
24	370-8261	CHARGER COUNTER	1	62	H-71015	FW 5/16 ID X 3/4 OD SS	7
25	390-2328	SWITCH, VACUUM SHUTOFF	1	63	H-71059	LW #10, SS	8
26	390-2899	CONTROLLER V4	1	64	H-71063	LW 1/4" SS	4
27	390-9615	FUSE, RESETTABLE, 15 AMP, 50V DC MAX	2	65	H-71212	FNW 1/4 ID X 1.0 OD SS	4
28	4-259	CONNECTOR, RED 50, HOUSING ONLY	1	66	H-72398	PPH #8-32 X 1/2" S/S	8
29	5-223	LIMIT SWITCH	1	67	H-72418	PPH #8-32 X 1" S/S	2
30	5-234	SWITCH, ROCKER, DPDT, ON/ON	1	68	H-72486	PPH #4-40 X 1/2" S/S	2
31	5-293	15 AMP RELAY	1	69	H-72494	PPH #4-40 X 1" S/S	2
32	5-728	DETERGENT WARNING PLATE	1	70	H-72534	PPH #10-32 X 3/4" S/S	4
33	5-892	TOGGLE, ON-OFF, SPST	3	71	H-72588	PPH 1/4-20 X 5/8" SS	1
34	7-227	BUTTON COVER	2	72	H-73758	BHSCS 1/4 - 20 X 1-3/4" SS	4
35	7-228	SWITCH MOUNT PLATE	4	73	H-74420	CB 1/4" - 20 X 1.0" SS	1
36	7-229	PUSH BUTTON SWITCH	4	74	H-74429	CB 5/16" - 18 X 3/4" SS	5
37	7-229D	PUSH BUTTON SWITCH	1	75	H-9307K74	GROMMET, 1" ID X 1-3/4" OD BUNA-N	2
38	7-283	SWITCH, TOGGLE, MOM/OFF/MOM (DPDT)	2				

ROUND DISK BRUSHES:

NOTICE

The ## in Disk Column Denotes Desk Pad Size: 13" or 14"

BRUSHES	DISK	LEVEL
Super Grit	##-382SS	Very High
Tough Grit	##-382S	High
Midi Grit	##-382C	Medium
Light Grit	##-382PS	Moderate
Poly	##-382P	Light
Nylon	##-382N	Light
Tampico	##-382T	Light
Pad Driver	##-382D	
Diamond Driver	##-382DD	

ROUND DISK PADS:

NOTICE

The ## in Disk Column Denotes Desk Pad Size: 13" or 14"

DISK PADS	DISK	LEVEL	COLOR
Super Black	##-422BB	Very High	Black
Black	##-422B	High	Black
Brown	##-422BR	High	Brown
Green	##-422G	Medium	Green
Blue	##-422BL	Moderate	Blue
Red	##-422R	Moderate	Red
White	##-422W	Light	White

CYLINDRICAL BRUSHES:

BRUSHES	MODEL 25" CYLINDRICAL	MODEL 29" CYLINDRICAL	LEVEL
Tough Grit	236-697S	276-697S	High
Midi Grit	236-697C	276-697C	Medium
Light Grit	236-697PS	276-697PS	Moderate
Nylon	236-697N	276-697N	Light
Tampico	236-697T	276-697T	Light

SQUEEGEE BLADE KITS & COMPLETE SQUEEGEE ASSEMBLIES:

SQUEEGEE SIZE	26" DISK DECKS	24" EDGE DECKS	28" DISK DECKS	28" EDGE DECKS	25" CYL. DECKS	29" CYL. DECKS
36" Squeegee	Standard	Standard	Standard	Standard	Standard	Optional
42" Squeegee	Optional	Optional	Optional	Optional	Optional	Standard

SQUEEGEE SIZE	LINATEX BLADE KIT	GUM RUBBER BLADE KIT	URETHANE BLADE KIT	COMPLETE SQUEEGEE ASSEMBLIES
36" Squeegee	36-770L	36-770G	36-770U	36-7180
42" Squeegee	42-770L	42-770G	42-770U	42-7180

SQUEEGEE MATERIAL:	USED FOR:
LINATEX	Provides best wear and tear resistance. Not designed for use with harsh chemicals.
URETHANE	Provides best resistance when dealing with harsh chemicals, oils, fuels, etc.
GUM	Provides best drying performance on rough/grouted floor types by sealing over irregularities. Short life.

NOTICE
 Squeegee blade kits include (1) Rear Blade, (1) Front Blade, and (2) Caster Wheels with hardware.

NOTICE
 Squeegee Assemblies (complete) listed above all come with Linatex blades.

NOTICE
 Size is stamped into the top of the painted steel squeegee body on all squeegee's.

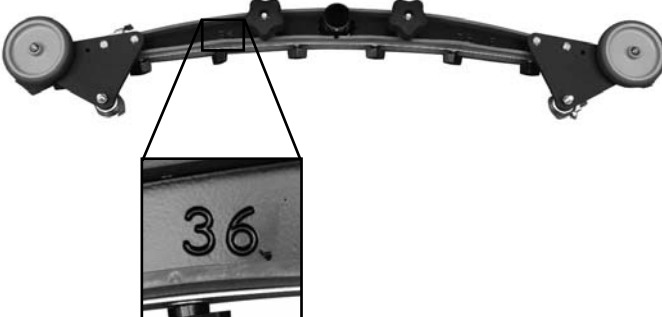

MINI-HD

Side Model Sticker - MINI-HD Part #: 175-1515

FACTORYCAT®

Front FactoryCat Sticker Part #: 370-7201

BLANK

THIS PAGE WAS INTENTIONALLY LEFT BLANK

FACTORYCAT[®]

1711 South Street
Racine, WI 53404
www.factorycat.com
Tel. US: 800-634-4060
Tel. Int: (001) 262-681-3583