

SelectGloss™ 21PH, 21PK

SelectGloss™ 27PK, 27PO, 27PR

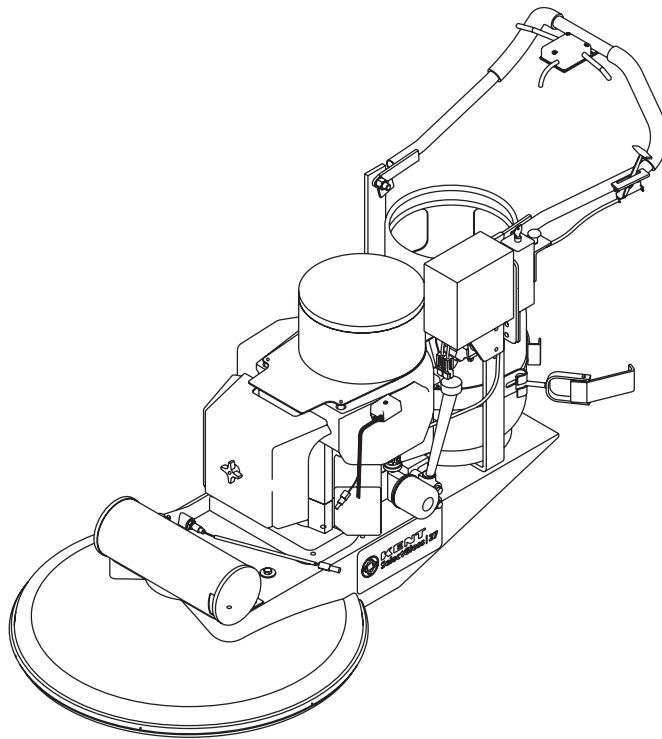

OPERATOR MANUAL AND PARTS LIST
Kent/Euroclean MODELS 56649654(21PH), 56649655(21PK)
56649656(27PK), 56649657(27PO / OBS), 56649930(27PR)

KENT

Simple. Clean.

10/02 revised 10/05 Form Number 56041536

IMPORTANT SAFETY INSTRUCTIONS

This machine is only suitable for commercial use, for example in hotels, schools, hospitals, factories, shops and offices other than normal residential housekeeping purposes.



ATTENTION!

Please read and adhere to all of the following Instructions before operating propane equipment.

- 1 The fuel supply system and cylinder connections of the floor maintenance machine shall be checked for leakage immediately after a cylinder is connected.
- 2 Connection and disconnection of cylinders shall be done in a well ventilated area with no source of ignition with 10 ft. (3m) from the point of connection.
- 3 When the engine of a floor maintenance machine is running the operator shall not leave the unit unattended.
- 4 When a floor maintenance machine is not in use and stored indoors, the cylinder shall be removed and stored outdoors and protected from damage and tampering.
- 5 A sign indicating "NO SMOKING" shall be permanently displayed at the storage area. The sign shall be in accordance with the sign required In Clause 10.12.3 of CAN/CGA-b149.2-M91, Propane Installation Code. (Does not apply in industrial buildings).
- 6 When the cylinder is attached to the floor maintenance machine for use, the operator shall not leave the unit unattended except for short periods of time such as rest stops, washroom or meal stops.
- 7 A floor maintenance machine shall only be used In buildings:
 - a. provided with continuous mechanical ventilation that removes the products of combustion to the outdoors of not less than 300 CFM for each 10,000 Btu input or fraction thereof;
 - b. provided with natural ventilation of not less than 300 CFM for each 10,000Btu input or fraction thereof, based on a maximum of one quarter air change per hour for the net building volume.
- 8 The owner of a floor maintenance machine must ensure that the operator has participated in a course authorized by the manufacturer of the unit on the safe handling of propane and the safe operation of the machine.
- 9 The owner of a floor maintenance machine shall ensure that the unit is maintained in accordance with the manufacturer's recommended maintenance procedures in a safe operating condition and the owner shall maintain a record of the maintenance for a period of two years.
- 10 Before transporting a floor machine, the cylinder shall be securely fastened, with the system valve closed and the cylinder shall be located in a well ventilated space.

SAVE THESE INSTRUCTIONS

SAFETY PRECAUTIONS

This LPG (Liquefied Petroleum Gas) machine is intended for commercial use; It is designed to clean floors. Do not use the machine other than described in this Operator Manual.

All operators must read, understand and practice the following safety precautions:

The following safety alert symbol is used throughout this manual as indicated in their descriptions.

WARNING!

To warn of hazards or unsafe practices that could result in severe personal injury or death.

CAUTION!

To identify actions that must be followed for safety operation of equipment.

The following information signals potentially dangerous conditions to the operator of equipment.

1. DO NOT OPERATE:

- * Unless trained and authorized.
- * Unless operator manual is read and understood.
- * If it is not in proper operating condition.

2. BEFORE OPERATING MACHINE:

- * Check for fuel oil and liquid leaks. If leakage is detected, shut off fuel supply at tank immediately.
- * Keep sparks and open flame away from refueling area.
- * Make sure area is well ventilated.
- * Remove any loose objects on floor.

3. WHEN OPERATING MACHINE:

- * Always wear eye protection.
- * Always use extreme caution when maneuvering.
- * If you smell gas: shut off LPG valve immediately, open windows, do not touch any electrical switches, extinguish any open flame and immediately call your gas supplier.
- * Do not smoke or allow smoking in the vicinity.
- * Go slow on inclines and slippery surfaces.
- * Do not place flammable objects such as fuel, matches, etc., close to the engine.
- * Report machine damage or faulty operation immediately.
- * Do not run continually over one minute in the park or tilted back position, longer periods will affect oil flow and cause damage to the engine.
- * Be careful not to touch the muffler.
- * Do not leave machine unattended while engine is running.
- * Keep hands, feet, hair, and loose clothing, etc. away from revolving pad and pulleys.
- * Do not attempt to change pad while engine is running.

4. BEFORE LEAVING MACHINE:

- * Stop on level surface.
- * Remove key (if applicable).
- * Turn off LPG valve on tank.

5. WHEN SERVICING MACHINE:

- * Keep hair, hands, feet, clothing, etc., away from moving parts.
- * Wear eye and ear protection when using pressurized air or water.
- * Keep flames and sparks away from fuel system service area. Keep area well ventilated.
- * Do not smoke or allow smoking in the vicinity.
- * Never use non-U.L. listed fuel tank or component as a substitute.
- * Use manufacturer supplied or approved replacement parts.

WARNING!

Engine emits toxic gases. Severe respiratory damage or asphyxiation can result. Provide adequate ventilation. Consult with your regulatory authorities for exposure limits. Keep engine properly tuned.

WARNING!

LP gas is extremely flammable and is explosive under certain conditions.

WARNING!

Machine moves when motor is running. Stop motor before leaving machine.

WARNING!

Do not store machine outdoors and avoid getting wet.

WARNING!

The use of supplies other than those recommended by manufacturer may cause damage.

TABLE OF CONTENTS

IMPORTANT SAFETY INSTRUCTIONS	2
SAFETY PRECAUTIONS	3
INTRODUCTION	4
MACHINE SETUP	5
CHECKING OIL LEVEL AND FILTERS	5
ADJUSTING HANDLE HEIGHT	5
INSTALLING OR CHANGING LPG FUEL TANK	5
INSTALLING OR REMOVING PAD DRIVER AND PADS	5
MACHINE OPERATION	6
STARTING MACHINE	6
OPERATING ELECTRIC CLUTCH (OPTIONAL)	6
STOPPING MACHINE	6
EMERGENCY STOPPING	6
WHILE OPERATING MACHINE	6
MAINTENANCE	7
DAILY MAINTENANCE	7
WEEKLY MAINTENANCE	7
MONTHLY MAINTENANCE	7
QUARTERLY MAINTENANCE	7
LIFE OF MACHINE	7
FUEL SYSTEM	7
CHANGING THE OIL	7
ADJUSTING BELT TENSION	8
REFUELING AND STORING TANKS	8
REFUELING LP GAS TANKS	9
STORING LP GAS TANKS	9
STORING MACHINE	10
TRANSPORTING MACHINE	10
TROUBLE SHOOTING GUIDE	11
STANDARD PARTS	
21PH HONDA	12
21PK KAWASAKI	12
27PO ONAN P248 (20HP)	14
27PK KAWASAKI	14
27PR ROBIN	16
ROBIN ZXV 653 ENGINE	18
ROBIN ZXV 653 CARBURETION SYSTEM	20
KAWASAKI AUTOMATIC SHUT DOWN SYSTEM	22
HONDA FUEL SYSTEM	24
KAWASAKI FUEL SYSTEM	25
ROBIN FUEL SYSTEM	26
ELECTRIC CLUTCH ASSY	27
KILL SWITCH ASSY	28
KAWASAKI FUEL LOAD BLOCK	29
KAWASAKI SCHEMATIC & HARNESS	30

INTRODUCTION

This manual will help you get the most from your **Kent / Euroclean™ SelectGloss™**. Read it thoroughly before operating the machine.

This product is intended for commercial use only.

PARTS AND SERVICE

Repairs, when required, should be performed by Kent / Euroclean service personnel using Kent / Euroclean original replacement parts and accessories.

Call Kent / Euroclean for repair parts or service. Please specify the Model and Serial Number when discussing your machine.

NAME PLATE

The Model and Serial Number of your machine are shown on the Nameplate on the machine. This information is needed when ordering repair parts for the machine. Use the space below to note the Model and Serial Number of your machine for future reference.

MODEL NUMBER _____

SERIAL NUMBER _____

UNCRATING

When the machine is delivered, carefully inspect the shipping carton and the machine for damage. If damage is evident, save the shipping carton so that it can be inspected. Contact the Kent / Euroclean Customer Service Department immediately to file a freight damage claim.

MACHINE SET UP

CHECKING OIL LEVEL AND FILTERS

- 1 Check oil level prior to starting machine. Use proper amount and specified oil, in order to prevent engine damage. When filling or changing oil, add more than one quart (946.3ml) -then check dip stick in cap. Add additional oil if necessary but do not overfill

The manufacturer recommends the use of 10W30 oil. ALWAYS CHECK OIL DAILY BEFORE USING MACHINE.

ATTENTION!

When checking oil, machine should be turned OFF and on level surface. Remove dipstick and wipe clean, then replace dipstick. For Honda, Kawasaki and Robin the cap should not be screwed in. To check Onan engine, the cap must be screwed in all the way. ALWAYS REFER TO YOUR ENGINE MANUAL.

- 2 Be sure air filter is free of dust/debris and other obstructions.
- 3 Check and clean recoil and carburetor filters if necessary. (See Engine Owners Manual)

ADJUSTING HANDLE HEIGHT

Machine is equipped with an adjustable handle for comfort and use of operators of different heights. With a 9/16" wrench, simply adjust handle at pivot points until desired operating position is reached and then retighten bolts.

INSTALLING OR CHANGING LPG FUEL TANK

NOTE: For refueling tank, see "REFUELING AND STORING TANKS".

- 1 Push machine in a designated safe area.

NOTE: Move to Step 6 for tank installation.

- 2 Close LPG tank valve on installed tank.
- 3 Operate engine until it stops from lack of fuel. (See Machine Owners Operation)

FOR SAFETY: Never release or bleed tank inside building or enclosed areas.

FOR SAFETY: When servicing machine, keep flames and sparks away from fuel system service area. Keep area well ventilated.

- 4 Put on gloves and remove service coupling by turning counter-clockwise.

- 5 Unlatch and remove empty LPG fuel tank from machine and store tank in a designated, safe area.
- 6 Carefully put full LPG tank on machine and position valve nozzle towards engine.

NOTE: Make sure LPG fuel tank matches fuel system (Vapor System Only).

CAUTION!

Never use a fuel tank not intended for machine.

- 7 Fasten tank hold-down clamp to securely lock tank in position. Adjustment to hold-down clamp can be made by threading latch in or out.
- 8 Connect LPG fuel hose to valve nozzle by turning service coupling clockwise (Tighten according to tank supplier recommendations). Make sure service coupling is clean and free of damage. Also, make sure it matches machine service coupling.

ATTENTION!

When installing tank, be careful not to cross thread service coupling.

- 9 Open tank service valve slowly and check for leaks. Close service valve immediately if a LPG leak is detected.

INSTALLING OR REMOVING PAD DRIVER AND PADS

Consult an authorized distributor to assist you in choosing the correct pad for your specific cleaning need.

Pad Driver Installation:

- 1 Lean machine on left side (Dip stick tube down).
- 2 Place pad driver on drive shaft and spin pad driver clockwise to install.

Pad Installation:

- 1 Tilt machine back on the rear caster (Park Position).
- 2 Remove plastic centerlock ring from pad driver. Center pad on pad driver and secure with centerlock ring.

Pad Driver Removal :

- 1 With knee, apply downward pressure on bell of machine deck.
- 2 Place 3/4" (19 mm). Open end wrench onto top of drive shaft.
- 3 With rubber mallet, strike wrench to break loose shaft from pad driver (counter-clockwise).
- 4 Lean machine on left side (Dip stick tube down).
- 5 Remove pad driver by spinning off counter-clockwise.

MACHINE OPERATION

FOR SAFETY: Do Not operate machine unless Operation Manual is read and understood.

STARTING MACHINE

- 1 With machine on level surface. check oil level prior to starting machine.
- 2 Tilt machine back onto rear caster (Park Position).
- 3 Remove any packing materials and obstructions from drive system.
- 4 Turn LPG fuel knob ON tank. Check LPG gas level meter.

NOTE: Opening service valve too quickly may cause service check valve to stop flow of LPG fuel. If check valve stops fuel flow, close service valve, wait a few seconds and open valve slowly again.

- 5 Push throttle lever to choke position for Honda engine only. All other engines start in IDLE position.
- 6 Press start button OR turn key (if required) to engage starter. Do not engage starter button for more than 20 seconds at a time. If starter overheats it trips an internal overload switch and will not crank over. Wait at least 20 to 30 seconds between tries. When engine starts, ease throttle back to running position. Do not hold starter button in a continuous ON position, starter will burn out.

NOTE: For Electric Clutch model, see "OPERATING ELECTRIC CLUTCH".

CAUTION!

Be careful not to allow the machine to come in contact with loose tiles or other loose materials, remember the pad driver is moving at very high speed, and Injury can occur to the operator or passers by If pad driver flings the loose material.

OPERATING ELECTRIC CLUTCH (OPTIONAL)

- 1 Once engine starts, move throttle control to SLOW rpm.
- 2 With throttle in SLOW, engage clutch by squeezing trigger switch.
- 3 After clutch is engaged, move throttle to 3/4 throttle position and then lower pad driver to floor.

CAUTION!

Never engage clutch in fast run position or with pad driver on floor, this will cause damage to clutch.

STOPPING MACHINE

- 1 Turn LPG valve OFF at tank while running. This serves to purge or bleed fuel hoses and carburetor system of fuel, so that there is no danger of gas escaping from lines when tank is removed for outside storage.
- 2 Tilt machine back on rear caster .
- 3 Engine will stop running when fuel lines bleed clear.
- 4 Pull throttle lever to STOP position after engine has stopped.
- 5 Turn key off if equipped.

EMERGENCY STOPPING

- 1 Pull throttle back to STOP OR turn off key if equipped.
- 2 Turn LPG valve OFF at tank.

NOTE: Engine may back fire when stopped in this manner.

If machine is equipped with Kill Switch Option, activate switch.

WHILE OPERATING MACHINE

WARNING!

Exhaust contains poisonous carbon monoxide gas. Avoid Inhalation of exhaust gases. Never operate machine in a confined area without proper ventilation.

- 1 Refer to (SAFETY PRECAUTION: WHEN OPERATING MACHINE) on page 4.
- 2 Do not run machine for more than 15 seconds in one spot or damage will occur to the floor.
- 3 Do not leave unattended in idle position or with engine running period. If machine needs to be idled for short periods, tilt machine back and move throttle to idle. Machine should now idle safely.

ATTENTION!

Do not Idle more than 5 minutes, longer periods will affect oil flow and will cause damage to the engine.

- 4 For easier maneuverability, always start on right side of aisle.

MAINTENANCE



WARNING!

Before attempting any maintenance procedures on machine, stop on level surface, shut off machine and turn off LPG valve at tank.



ATTENTION!

Repairs and adjustments must be performed by authorized and trained personnel.

To keep machine in good working condition, simply follow the daily, weekly, and monthly maintenance procedures.

NOTE: Always record maintenance and service.



ATTENTION!

Always keep machine free from dust and lint; the engine is air cooled and for proper air flow to cool the engine, the recoil filter must remain clean.

DAILY MAINTENANCE (Every 4 Hours of Operation)

- 1 Check oil level (Use 10W30 oil only).
- 2 Clean recoil filter .
- 3 Check belt tension by pinching belt together. Belt should only depress 1/2" (13mm).
- 4 Clean all air filters by blowing out dust and dirt and/or washing the foam filters (recoil and carburetor pre- filter) with warm, sudsy water and rinsing clean. *(Be careful not to wet the paper carburetor filters.)* Be sure filters are clean and dry before use. Do not oil foam or filter .
- 5 Make sure all components are secure and tight.
- 6 Check pad daily (clean or replace).
- 7 Clean machine.
- 8 For Dust Control models, clean dust collection bag.

WEEKLY MAINTENANCE (Every 20 Hours of Operation)

- 1 Check oil level. Change oil and filters at 50 hours of operation. Use 10W30 Motor Oil or other no ash motor oils designed for use in propane engines. Use of non-recommended oil may void the engine warranty.

See Engine Owners Manual for complete servicing details

- 2 Inspect carburetor air filter by removing wing nut and over on top of carburetor. Replace if dry or deposits are present.
- 3 Check belt for tension. Tighten if loose. If worn, replace with proper belt. *(See "ADJUSTING BELT TENSION")*. Refer to parts schematic for size of belt required.
- 4 Inspect and tighten nuts and bolts on engine and frame.
- 5 Examine all propane hoses and connections for leaks or wear. Replace if necessary.
- 6 Grease wheels. Use white lithium grease only and use no more than 1 pump of grease. More grease than recommended will push seal and dust cover out, allowing dust and other foreign materials into the bearings, shortening the life of the wheel significantly.

MONTHLY MAINTENANCE (Every 80 hours of Operation)

- 1 Perform all daily and weekly services.
- 2 Torque the head bolts when engine is cold in a crisscross pattern as per engine manufacturers specifications *(See Engine Owners Manual)*.
- 3 Check valve clearance with cold engine as per engine manufacturers specifications *(See Engine Owners Manual)*.
- 4 Torque valve cover as per engine manufacturers specifications *(See Engine Owners Manual)*.
- 5 Inspect spark plug. Replace if necessary.
- 6 Change oil and oil filter.
- 7 Inspect fuel hoses for leak (repair as needed).
- 8 Wash undercarriage of machine to remove all dust and debris.
- 9 To ensure proper ventilation, remove engine cover and clean engine.
- 10 Replace air filter element and foam filter.

QUARTERLY MAINTENANCE (Every 250 Hours of Operation)

- 1 Perform all of the above maintenance procedures and have engine checked by an Authorized Service Center.
- 2 Check air gap in electronic ignition coil.
- 3 Check valves with engine cold.

NOTE: Consult Engine Manual for complete servicing and adjustments information.

LIFE OF MACHINE

- 1 Change oil regularly.
- 2 Clean recoil filter regularly.
- 3 Clean carburetor filter regularly.
- 4 Keep machine clean from dust and debris.

FUELSYSTEM

Adjustments for the air/fuel mixture must be made only by an Authorized Service Center. Improper adjustments can cause high levels of carbon monoxide emissions which may cause carbon monoxide poisoning or it can lead to engine damage.

- Idle speed is adjusting by turning adjustment screw on regulator.
- Fuel flow is adjusted by adjustment screw on carburetor spud-in.

CHANGING THE OIL

The manufacturer recommendations 10W30 oil.

- 1 Run engine for five minutes to warm oil.
- 2 Make sure machine is on level surface. Locate oil drain plug on rear of engine beside oil cap and remove by turning counter-clockwise with wrench.
- 3 Allow oil to run into pan under machine. Allow to completely drain.
- 4 Install drain plug and tighten drain plug by turning clockwise with wrench.
- 5 Slowly add one quart (946.3 ml) of 10W30 Motor Oil. Then check oil level with dip stick in oil fill cap. Add additional oil if necessary.
- 6 Replace oil-fill cap assembly. Hand tighten only.



ATTENTION!

Do not overfill and never run engine low on oil.



ATTENTION!

When checking oil, be sure cap is fully screwed out and free. Do not check oil by screwing cap in and then out again, this will give you a false reading.

ADJUSTING BELT TENSION

Tools required:

- 3/4" (19mm) open end wrench
 - 15/16" (24mm) deep-well socket.
- 1 Loosen Mounting Bolt on top side of machine while applying counter-pressure to Adjusting Nut on underside of deck.

NOTE: The mounting bolt must be loosened first.

- 2 Rotate Adjusting Nut counterclockwise with socket to apply tension to belt.
- 3 While holding the tension on the Adjusting Nut. Tighten Mounting Bolt.
- 4 Check belt tension by pinching belt together. Belt should only depress 1/2" (12mm).

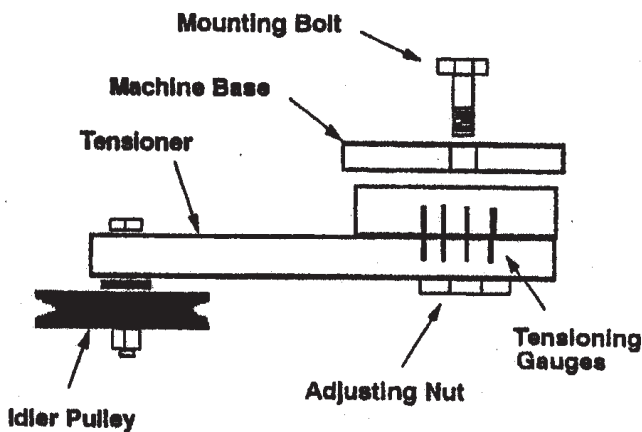

REFUELING AND STORING TANKS

The following information refers to United States regulations on propane. For outside the United States, owner, must assure that required regulations are met.

The manufacturer would like to acknowledge NFPA 58, Standard for Storage and Handling of Liquefied Petroleum Gases, 1993 Edition. This publication is available through the National Fire Protection Association (NFPA) in Quincy, Massachusetts (1-800-344-3555). The NFPA was established to set guidelines for, among other things, the use of propane.

Propane is a flammable gas whose vapors are heavier than air. It can explode under certain conditions. It is not different than other items commonly used today which must be operated in a safe way such as automobiles, gas stoves, airplanes, etc. Propane is odorized with an agent with a distinct odor that is recognizable at very low concentrations. This helps in identifying leaks even when they are small.

Awareness and basic safety precautions are required. As long as these precautions are followed, risk is negligible. Ignorance, however, could pose needless risk. Therein lies the reason behind NFPA 58 and the Safety Publication.

NFPA 58 categorizes propane-powered buffers with fork lift trucks, (see section 3-6.4.4). In essence, the only difference between the two lies in the ability of the buffer with its 20-pound tank to be stored in concealed areas (like janitor closets, etc.).

If a machine and its tank of propane were stored in a closet and a fire occurred, the propane in the tank could be a threat to fire fighters due to the potential for a B.L.E.V.E. (Boiling Liquid Expanding Vapor Explosion). Exposure of the tank to heat can also cause the relief valve to open thereby releasing flammable vapors that can cause the fire to intensify when ignited.

The NFPA Technical Committee prohibits the storage of such containers in buildings.

REFUELING LP GAS TANKS

NOTE: See "INSTALLING OR CHANGING LPG FUEL TANK" for Tank Removal.

The LP gas tank supplied with machine has a 20lb. (9.3kg), 5-gallon (18.9L) capacity. **DO NOT OVERFILL.** Overfilling will cause the regulator to freeze up. Use only D.O.T. and U.L. Listed propane tank and only fill tank at a reputable propane dealer .

DO NOT attempt to repair the propane tank yourself. Return tank to dealer for repair.

NOTE: Never use a tank not intended for the propane machine. Do not substitute tanks from barbecue grills, etc.

The manufacturer exclusively uses aluminum and steel cylinders that meet the Department of Transportation guidelines contained in the D.O.T. # 4ET240 and are additionally U.L. listed.

NFPA 58 discusses the major concerns for filling tanks properly in Chapter 4. In summary, the tank should never be completely filled with liquid. A tank that is completely full could create a hazard. The hazard is known as a hydrostatic pressure situation.

To illustrate this situation, suppose the temperature outside is very cold (perhaps well below freezing). You fill your tank outside and then bring it inside where the temperature is maybe 60 degrees Fahrenheit or warmer. An increase in air temperature will drive up the cylinder pressure placing stress on the tank. Before reaching a critical pressure point, the relief valve should open, relieving the pressure by venting vapor at the top of the tank. However, if there is no vapor at the top of the tank, this safety measure is compromised. Overfilled tanks do not allow this built-in safety feature to function properly.

ATTENTION!

Overfilling a tank usually results in liquid flowing through the hose and down into the regulator. This can result in damage to the machine.

If you observe frost on the regulator, someone has overfilled the tank. Take the tank to a safe outside location and vent the excess propane. Venting is accomplished by:

- 1 Removing the tank from machine.
- 2 Taking tank outside of building to safe area.
- 3 Opening the small relief valve located on top of machine.
- 4 Keep tank upright.
- 5 Allow to vent until fuel vapor is not visible.

Whether the tank is filled by weight (most accurate) or by volume, using a gage, make sure the person doing the filling is qualified.

CAUTION!

Avoid overfilling tanks. Only fill to 80% of capacity. The manufacturer recommends that refueling be accomplished by qualified personnel away from public buildings outside. We further recommend that additional tanks be used so that rather than refueling at the job site, a simple exchange of tanks occurs.

STORING LP GAS TANKS

ATTENTION!

Tanks (20lb.) should not be stored in buildings used by the public or frequented by anyone passing through or working in the building. Inside storage in buildings designated as shop or machinery facilities are acceptable.

Section 5-2.1.1 of the NFPA 58 says: "Containers in storage shall be so located as to minimize exposure to excessive temperature rise, physical damage or tampering."

Provision must be made for venting the actual storage area with both floor level and high level openings. This venting assures that the heavier than air propane gas will not settle in pockets, but disperse.

If storage is in a shop or machine storage area that is connected or a part of an office complex, it should be separated by a fire wall along with proper venting to the outside.

Since these requirements can seldom be found, outside open air storage is the most practical alternative.

When this option is used, the storage container may be located with "zero" clearance from the building and with at least 5' of space between the cage and the nearest building opening.

The tank must be in a secure, tamper-proof security storage enclosure that provides safety from accident or vandalism.

CAUTION!

Tanks must always be stored in the upright position. The upright position assures that the discharge is largely vapor rather than liquid. This is important from the standpoint of both the quantity of the potential flammable vapor/air mixture and the relieving capacity for the pressure relief device. (The escape of vapor presents much less hazard than the escape of liquid).

The manufacturer recommends that tanks be removed from the machine after use and stored accordingly. The machine can then be placed in a secure area inside, away from the tank.

NOTE: Local jurisdiction always prevails there may. Be varying requirements. Always check with the local authorities.

STORING MACHINE

- 1 Remove LPG tank from machine when not in use.

FOR SAFETY: Never release or bleed tank inside building or in enclosed areas.

NOTE: See "INSTALLING OR CHANGING LPG FUEL TANK" for Tank Removal.

- 2 Perform all Daily Maintenance procedures.
- 3 Change engine oil.
- 4 Store machine in cool, dry area, away from fuel tanks. Tilt machine back onto rear caster (Park Position).
- 5 Store tanks in an approved area.

NOTE: See "STORING LP GAS TANKS".

TRANSPORTING MACHINE

For ease of transportation, the machines handle can be folded over the engine. The tank can be transported on machine provided that tank hold-down clamp is securely fastened around tank and tank valve is turned completely OFF.



ATTENTION!

Never transport a machine in an enclosed area that has not had sufficient time to cool down.

TROUBLE SHOOTING GUIDE

PROBLEM	CAUSE	SOLUTION
Will not start.	No fuel or dirt in fuel line. Blown head gasket. Engine overload. Dirty air cleaner. Faulty spark plug. Fuel system out of adjustment. Defective ignition coil.	See Engine Owners Manual for servicing.
Hard to start.	Improper fuel, no fuel or dirt in fuel line. Engine overload. Dirty air cleaner . Faulty spark plug. Spark plug or head bolts loose. Blown head gasket. Timing, coil, or valve needs adjusting. Carburetor needs adjusting. Regulator needs adjusting. Insufficient vacuum.	See Engine Owners Manual for servicing.
Lacks power .	Improper valve clearance. Improper fuel or dirt in line. Faulty spark plug. Improper oil level. Valve seats need adjusting. Leaking head gasket. Governor needs adjusting. Worn rings.	See Engine Owners Manual for servicing.
Smell of burned rubber.	Belt out of adjustment.	See "ADJUSTING BELT TENSION".
Engine overheats.	Dirt in fuel line. Incorrect oil level. Engine overload.	
High fuel consumption.	Dirty air filters. Dirty air cleaners.	See Engine Owners Manual for servicing.
Machine stops suddenly.	Faulty spark plug. Pad not centered on pad driver . Incorrect pad size for pad driver. Oil shut down sensor activated.	See Engine Owners Manual for servicing. Add recommended oil.
Excess vibration.	Bolts loose on engine or deck of unit. No fuel or dirt in fuel line. Incorrect oil level. Engine overload. Dirty air filters. Faulty spark plug.	See Engine Owners Manual for servicing.

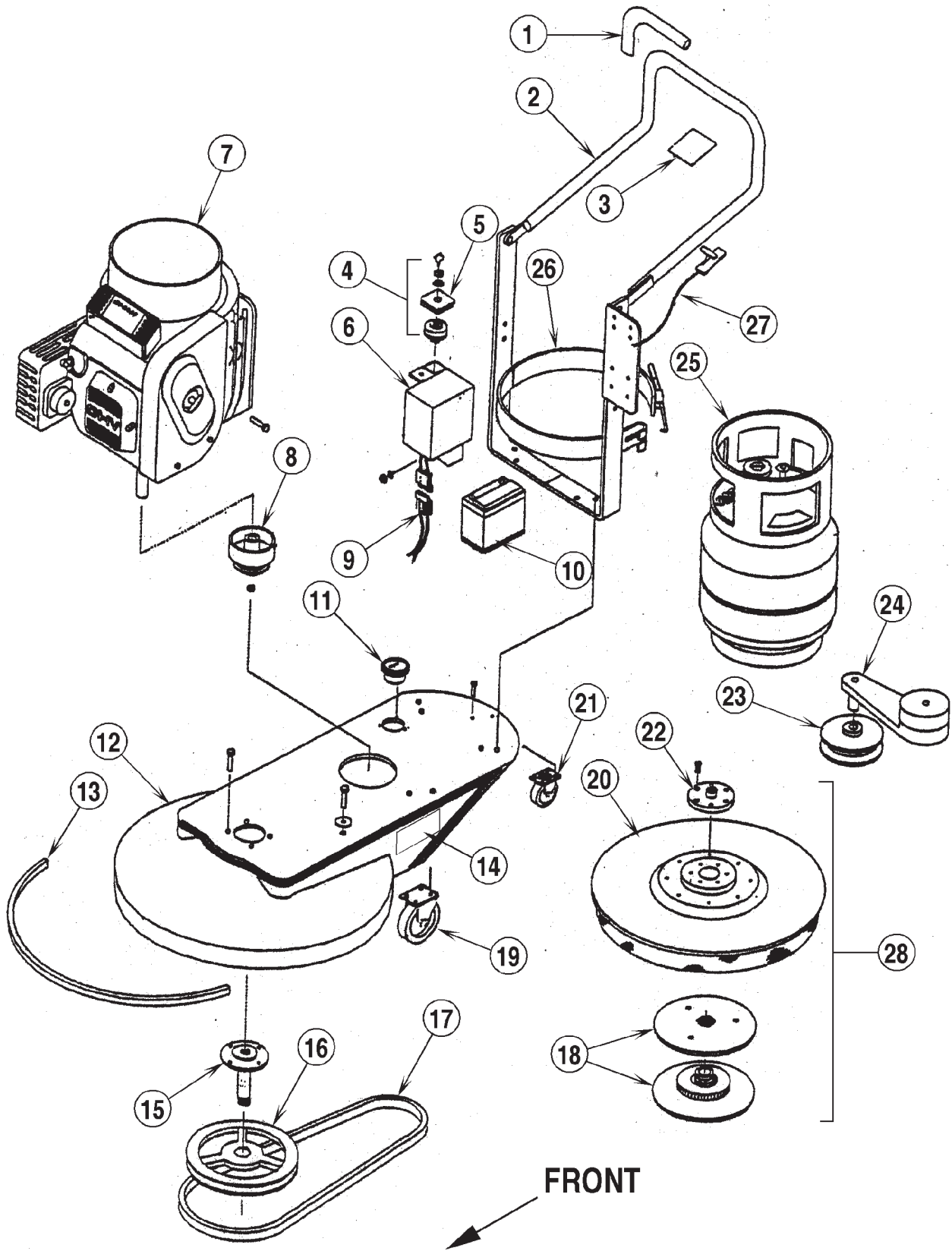

02-10	SELECTGLOSS™ 21PH / 21PK		
05-10	SelectGloss™		13

Item	Ref. No.	Qty	Description
1	56649812	2	Foam Hand Grip
2	56649816	1	FM Handle
3	56649726	1	Clutch Switch Mounting Plate
4	56102526	1	Key Switch
*	56102583	1	Replacement Key
5	56102527	1	Key Switch Holder
6	56649817	1	Battery Box
*	56649818	1	Key Switch Bracket
*	56649819	1	Choke Bracket (Kawasaki)
7	56102507	1	Kawasaki 17HP
	56102532	1	Honda 390 13HP
8	56102508	1	Pulley, 3.5 x 1
9	56102523	1	Battery Connector Complete (Kawasaki)
10	56102522	1	Battery, 12V
11	56102521	1	Hour Meter
12	56649820	1	Deck, 21" Aluminum
13	56649821	1	Bumper Molding
14	56015268	2	Decal, Kent SelectGloss 21
15	56102509	1	Front Bearing Assy
16	56102533	1	Pulley, 6.2
17	56649822	1	Belt, B x 40
18	56420120	1	Centerlock
19	56649823	2	Wheel W/Bracket, 6 x 5
	56649824	2	Wheel, 6 x 1.5
20	56102535	1	21" Flex Pad Driver
21	56102518	1	Caster, 3"
22	56102517	1	Flange
23	56102519	1	Idler Pulley
24	56102520	1	Tensioner Arm
25	56102524	1	Steel LP Tank
26	56649825	2	Velcro Tape
27	56102529	1	Throttle Cable
28	56102598	1	21" Flex Pad Driver Complete
**	56102618	1	21" Pad Driver Complete
*	56102538	1	Choke Cable (Kawasaki)
*	56102539	1	Honda Starter
**	56388355	1	21" Beige Pads (case of 5)
**	56102615	1	Honda GXV390 Engine Service Kit
**	56102617	1	Kawasaki 17hp Engine Service Kit
**	56102658	A/R	Two Tank Cage

* = Not Shown

** = Optional

NOTE: For engine information not listed in the Standard Parts List, refer to the appropriate Engine Parts Manual.

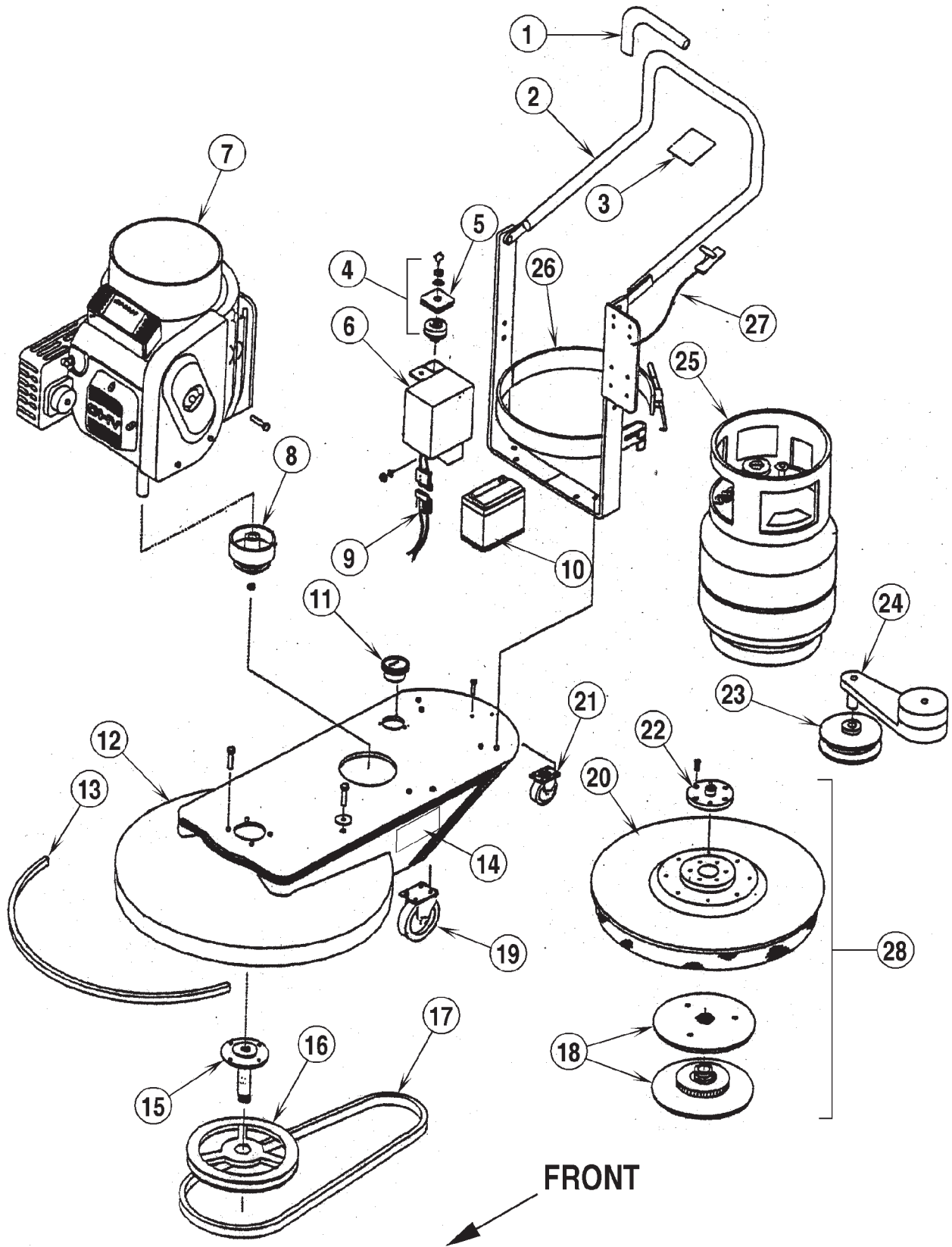

02-10	SELECTGLOSS™ 27PK / 27PO		
05-10	SelectGloss™		15

Item	Ref. No.	Qty	Description
1	56649812	2	Foam Hand Grip
2	56649816	1	FM Handle
3	56649726		Clutch Switch Mounting Plate
4	56102526	1	Key Switch
*	56102583	1	Replacement Key
5	56102527	1	Key Switch Holder
6	56649817	1	Battery Box
*	56649818	1	Key Switch Bracket
*	56649819	1	Choke Bracket (Kawasaki)
7	56102507	1	Kawasaki 17HP
	56102541	1	Onan 20HP
8	56102508	1	Pulley, 3.5 x 1
9	56102523	1	Battery Connector Complete (Kawasaki)
	56102542	1	Battery Connector (Onan)
10	56102522	1	Battery, 12V
11	56102521	1	Hour Meter
12	56649826	1	Deck, 27" Aluminum
13	56649821	1	Bumper Molding
14	56015207	2	Decal, Kent SelectGloss 27
15	56102509	1	Front Bearing Assy
16	56102510	1	Pulley, 8.5 x 1
17	56102512	1	Belt, B x 50
18	56420120	1	Centerlock
19	56649823	2	Wheel W/Bracket, 6 x 5
	56649824	2	Wheel, 6 x 1.5
20	56102514	1	27" Flex Pad Driver
21	56649827	1	Caster
22	56102517	1	Flange
23	56102519	1	Idler Pulley
24	56102520	1	Tensioner Arm
25	56102524	1	Steel LP Tank
26	56649825	2	Velcro Tape
27	56102529	1	Throttle Cable
28	56102516	1	27" Flex Pad Driver Complete
**	56102619	1	27" Pad Driver Complete
*	56102538	1	Choke Cable (Kawasaki)
*	56102543	1	Regulator Bracket (Onan)
**	56420163	1	27" Beige Pads (case of 5)
**	56102616	1	Onan 20 P248 Engine Service Kit
**	56102617	1	Kawasaki 17hp Engine Service Kit
**	56102658	A/R	Two Tank Cage

* = Not Shown

** = Optional

NOTE: For engine information not listed in the Standard Parts List, refer to the appropriate Engine Parts Manual.

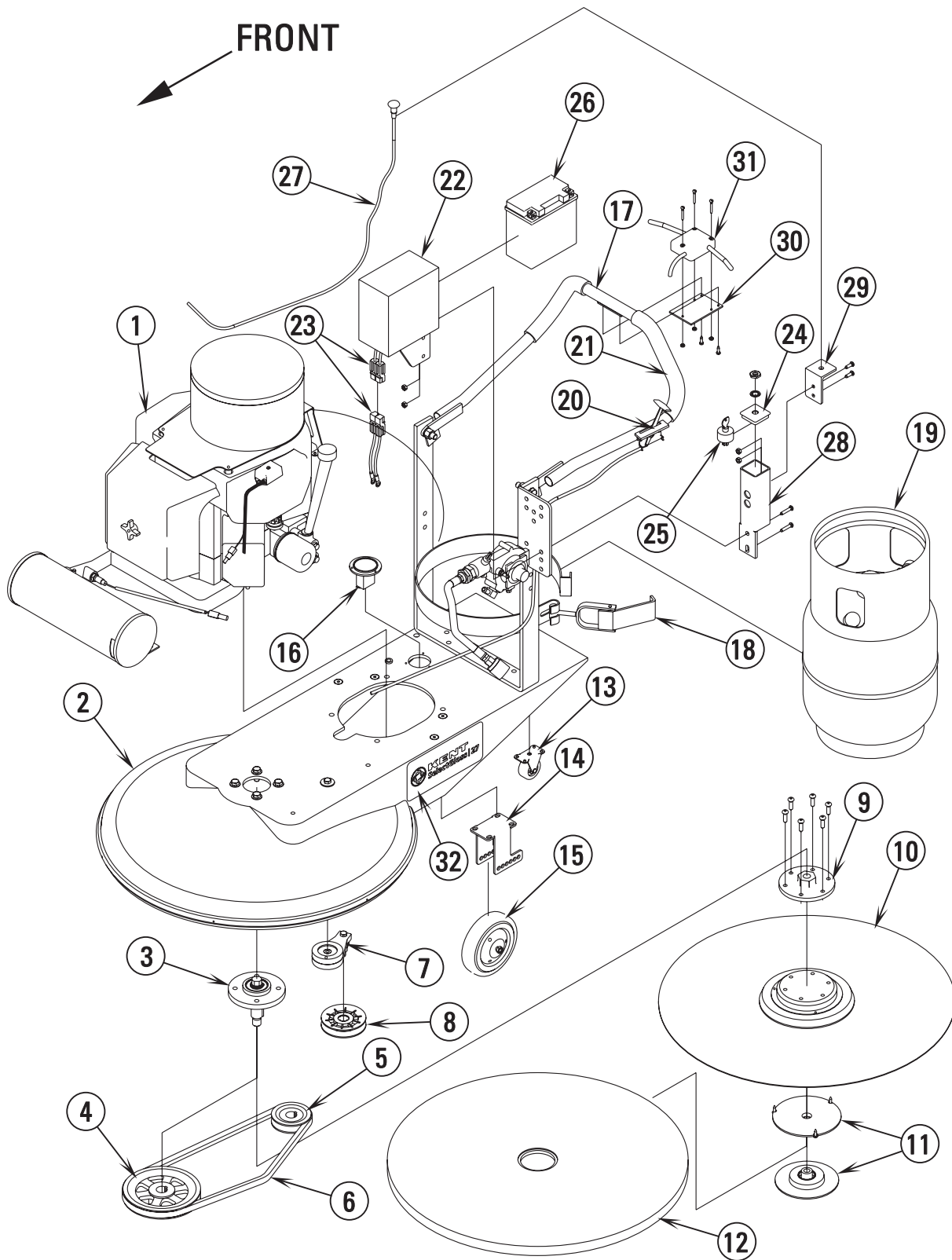

02-10	SELECTGLOSS™ 27PR		
05-10	SelectGloss™		17

Item	Ref. No.	Qty	Description
1	56102645	1	Robin ZXV 653 Engine
2	56649826	1	Deck 27" Aluminum
3	56102509	1	Front Bearing Assy Complete
4	56102648	1	Pulley, 7.0 x 1.0
5	56102508	1	Pulley, 3.5 x 1.0
6	56102649	1	Belt, B x 48
7	56102520	1	Belt Tensioner
8	56102519	1	Idler pulley
9	56102517	1	Flange
10	56102514	1	27" Flex Pad Driver
11	56420120	1	Center lock
12	56420163	A/R	27" Beige Pads (case of 5)
13	56649827	2	2" Caster W/Gray Wheel
14	56102651	2	Bracket Wheel 5"
15	56649824	2	Wheel, 6" x 1.5" W/Axle
*	56649823	2	Wheel W/Bracket (14 & 15)
16	56102521	1	Hour Meter
17	56649816	1	FM Handle
18	56102528	1	Toggle
19	56102524	1	Tank, LP Steel W/OPD
20	56102529	1	Throttle Cable
21	56649812	2	Hand Grip
22	56649817	1	Battery Box
23	56102650	1	Battery Connector Complete
24	56102527	1	Key Switch Housing
25	56102526	1	Key Switch
*	56102583	1	Replacement Key
26	56102522	1	Battery, 12V
27	56102538	1	Choke Cable
28	56649818	1	Key Switch Bracket
29	56649819	1	Choke Bracket
30	56649726	1	Clutch Switch Mounting Plate
31	56102575	1	Clutch Switch Assy Complete
32	56015207	2	Decal, Kent SelectGloss 27
**	56102646	1	Robin 22hp Engine Service Kit
**	56102658	A/R	Two Tank Cage

* = Not Shown

** = Optional

NOTE: For engine information not listed in the Standard Parts List, refer to the appropriate Engine Parts Manual.

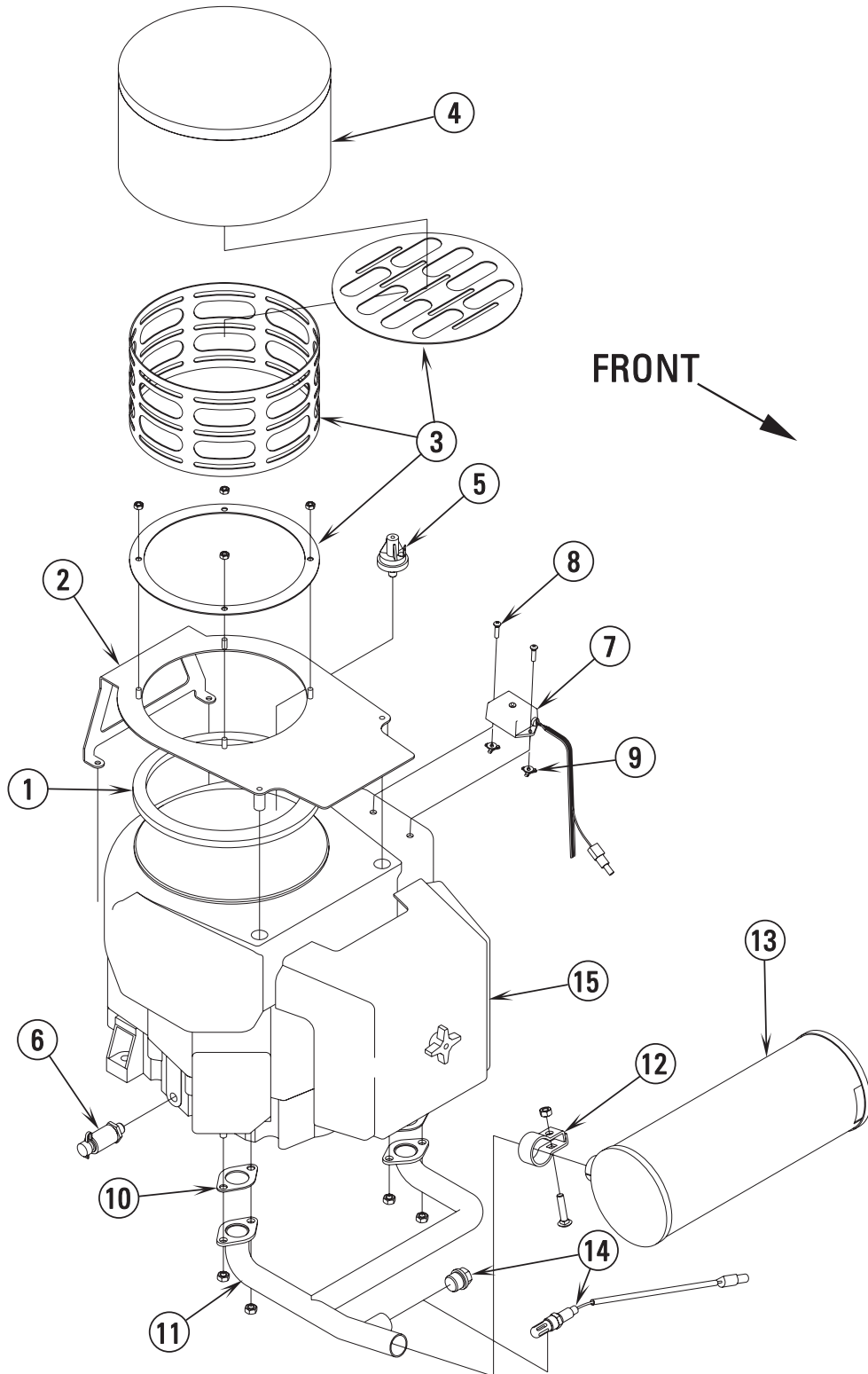

02-10	ROBIN ZXV 653 ENGINE		
03-7	SelectGloss™		19

Item	Ref. No.	Qty	Description
1	56102565	1	Recoil Filter Support gasket
2	56102632	1	Engine Cover
3	56102633	1	Filter Support Screen
4	56102634	1	Recoil Filter
5	56102563	1	Oil Pressure Switch
6	56102635	1	Oil Drain Valve
7	56102506	1	Automatic Shut Down system
8	56102637	2	Scr, Pan Phil 6-32 x .62
9	56102638	2	Nut, Jack 6-32
10	56102639	2	Exhaust Manifold Gasket
11	56102640	1	Exhaust Manifold
12	56102641	1	Muffler Clamp
13	56102642	1	Muffler, Catalytic
14	56102643	1	Oxygen Sensor
15	56102645	1	Robin ZXV 653 Engine
**	56102646	1	Robin 22hp Engine Service Kit

** = Optional

NOTE: For engine information not listed in the Standard Parts List, refer to the appropriate Engine Parts Manual.

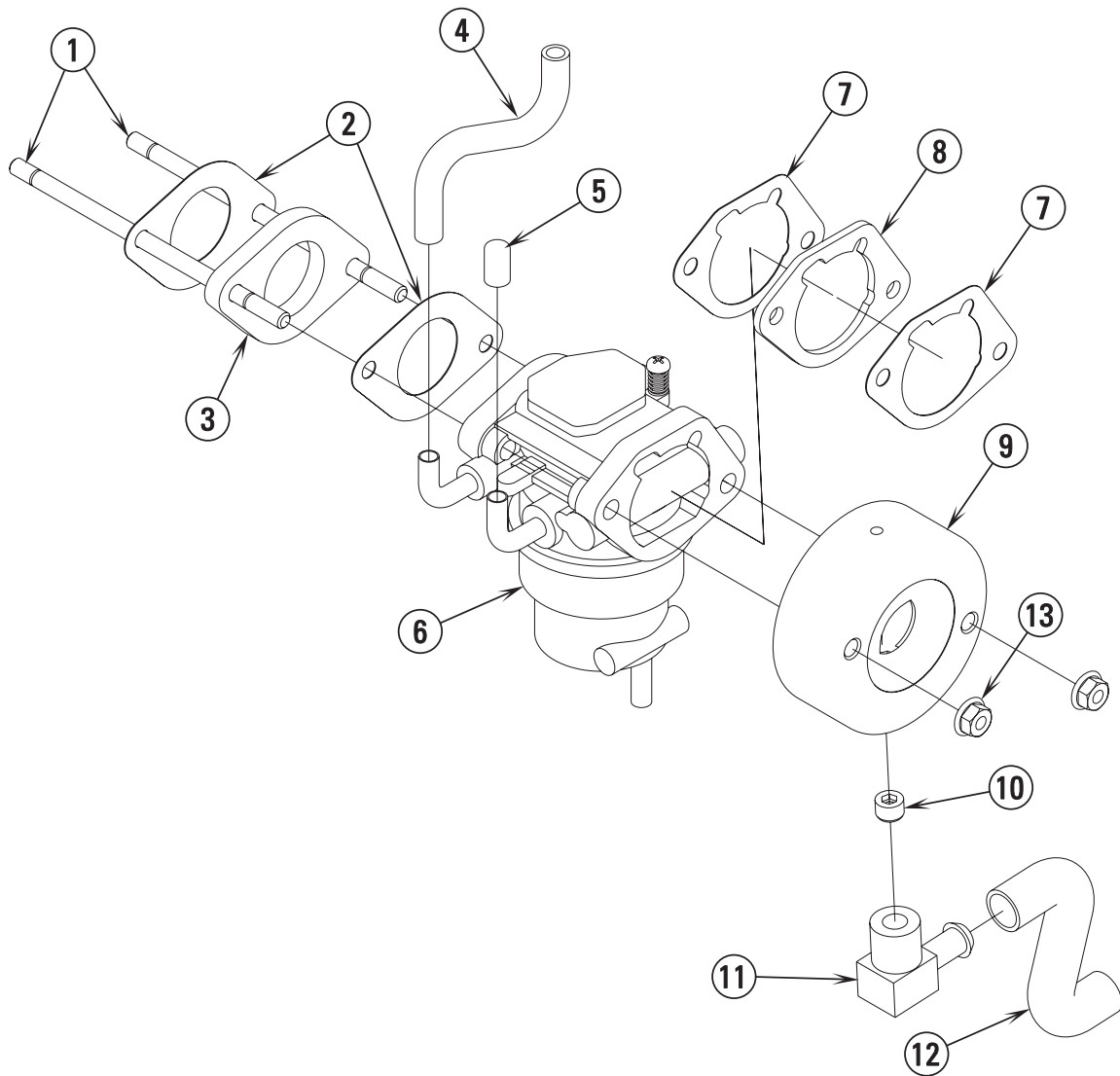

02-10	ROBIN ZXV 653 CARBURETION SYSTEM		
03-7	SelectGloss™		21

Item	Ref. No.	Qty	Description
1	56102590	2	Stud, M6 x 130
2	56102622	2	Gasket, Insulator
3	56102623	1	Insulator
4	56102549	1	Vacuum Hose
5	56102586	1	Rubber Cap ¼
6	56102624	1	Carburetor Assy
7	56102625	2	Gasket, Cleaner
8	56102626	1	Spacer, Air Cleaner
9	56102627	1	Fuel Load Block
10	56102629	1	Orifice #26
11	56102630	1	90 Elbow 3/8NPT x 5/16 Hose Barb
12	56102550	1	Fuel Hose
13	56102631	2	Flange Nut

NOTE: For engine information not listed in the Standard Parts List, refer to the appropriate Engine Parts Manual.

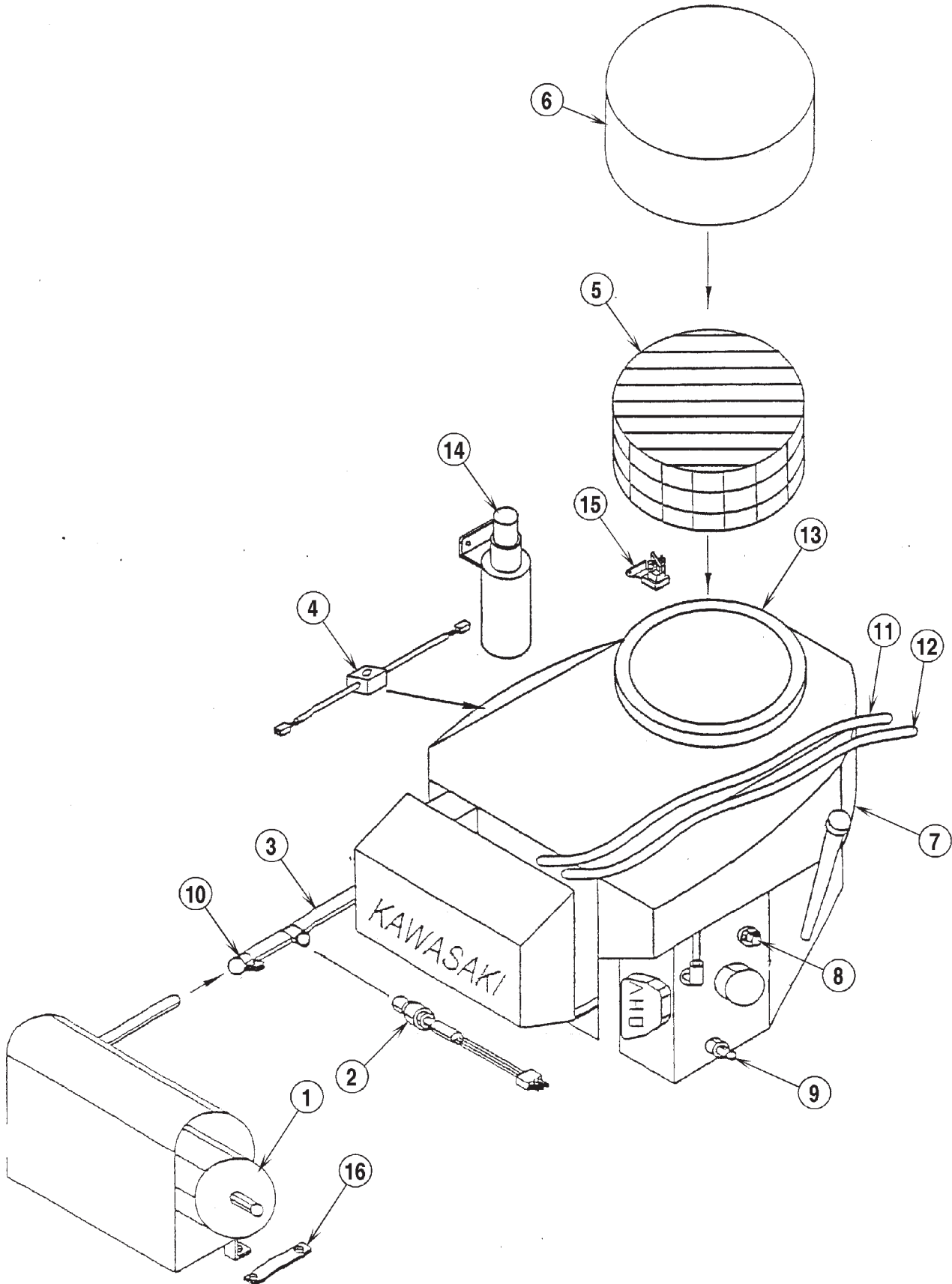

Item	Ref. No.	Qty	Description
1	56102560	1	Muffler (cat)
2	56102570	1	Oxygen Sensor
3	56102568	1	Manifold
4	56102571	1	Auto Shutdown
5	56102561	1	Support
6	56102562	1	Air Filter (recoil)
7	56102507	1	Kawasaki 17HP
8	56102563	1	Oil Pressure Switch
9	56102572	1	Oil Drain Valve
10	56102564	1	Muffler Clamp
11	56102550	1	Fuel Hose
12	56102549	1	Vacuum Hose
13	56102565	1	Recoil Filter Support Gasket
14	56102569	1	Starter
15	56102566	1	Starter Solenoid
16	56102567	1	Muffler Bracket (21" Only)

NOTE: For engine information not listed in the Standard Parts List, refer to the appropriate Engine Parts Manual.

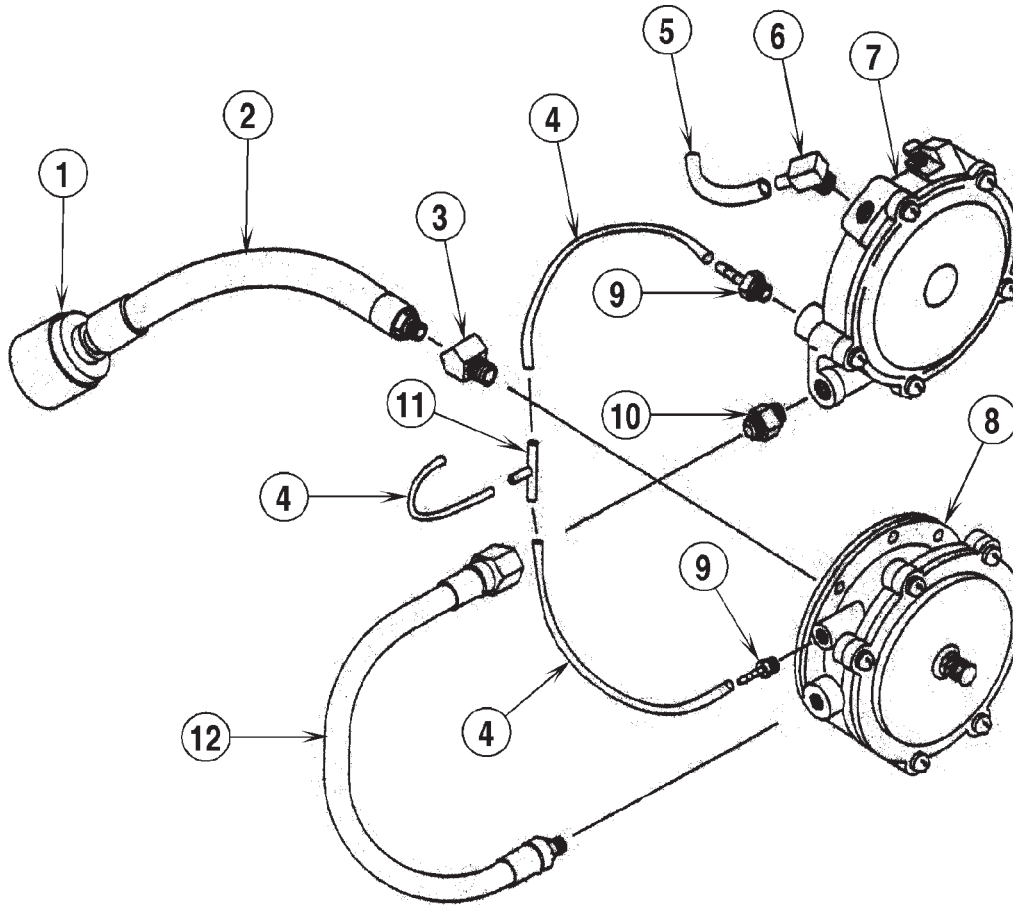

Item	Ref. No.	Qty	Description
1	56102547	1	Quick Coupler
2	56102546	1	LP Hose
3	56102548	1	Fitting, 1/4 x 90 Street Elbow
4	56102549	3	Hose, Vacuum
5	56102550	1	Hose, Fuel
6	56102551	1	Fitting, 3/8 Barb x 3/8 MP
7	56102555	1	Regulator
8	56102556	1	Lockoff
9	56102554	2	Fitting, 1/4 Barb x 1/4 MP
10	56102557	1	Fitting, 3/8 Flare x 1/4 MP
11	56102558	1	Vac Tee
12	56102559	1	LP Hose

NOTE: For engine information not listed in the Standard Parts List, refer to the appropriate Engine Parts Manual.

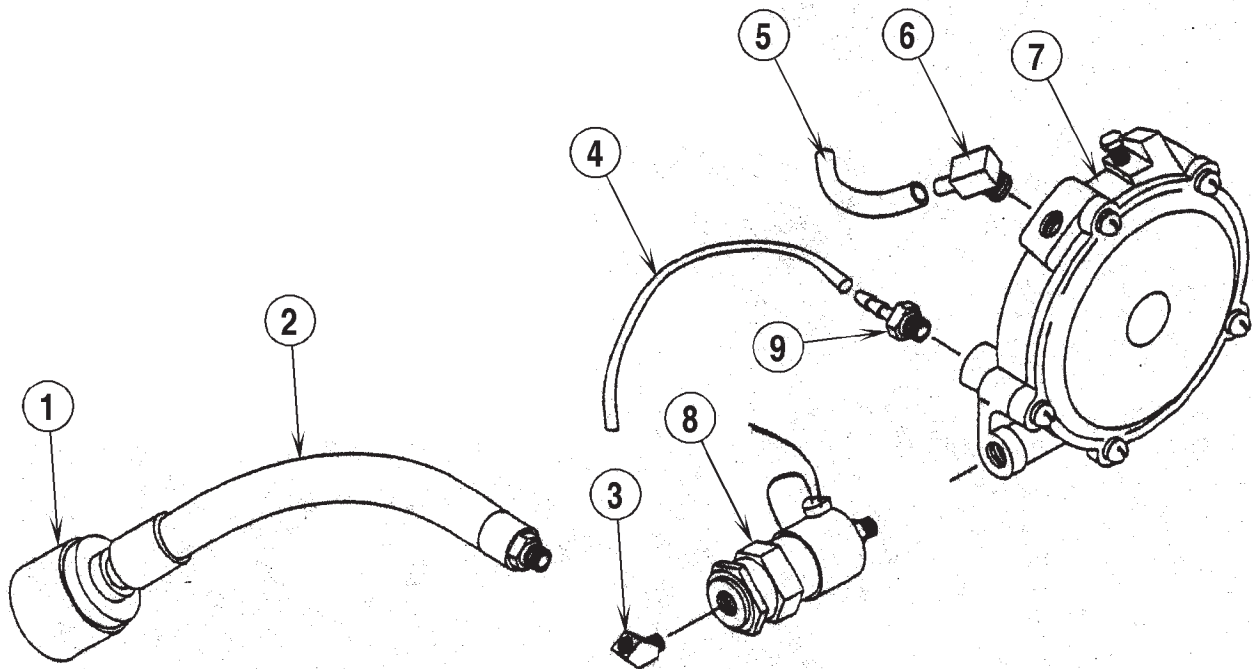

Item	Ref. No.	Qty	Description
1	56102547	1	Quick Coupler
2	56102546	1	LP Hose
3	56102548	1	Fitting, 1/4 x 90 Street Elbow
4	56102549	1	Hose, Vacuum
5	56102550	1	Hose, Fuel
6	56102551	1	Fitting, 3/8 Barb x 3/8 MP
7	56102552	1	Regulator
8	56102553	1	Fuel Lock W/Filter 12V
9	56102554	1	Fitting, 1/4 Barb x 1/4 MP

NOTE: For engine information not listed in the Standard Parts List, refer to the appropriate Engine Parts Manual.

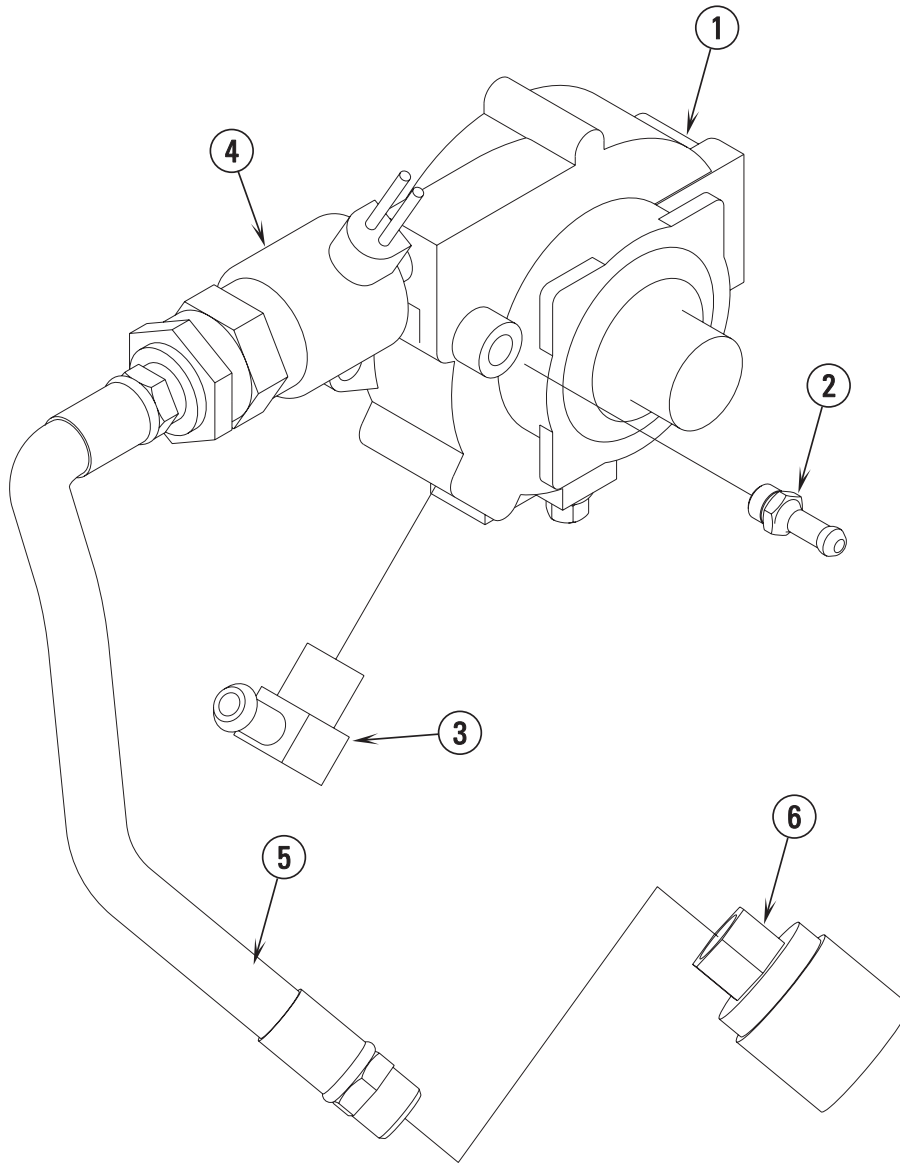

Item	Ref. No.	Qty	Description
1	56102552	1	Regulator
2	56102554	1	Fitting, 1/4 Barb x 1/4MP
3	56102551	1	Fitting, 3/8 Barb x 3/8MP
4	56102553	1	Fuel Lock W/Filter 12V
5	56102621	1	LP Hose 28", 1/4 x 1/4NPT
6	56102547	1	Quick Coupling

NOTE: For engine information not listed in the Standard Parts List, refer to the appropriate Engine Parts Manual.

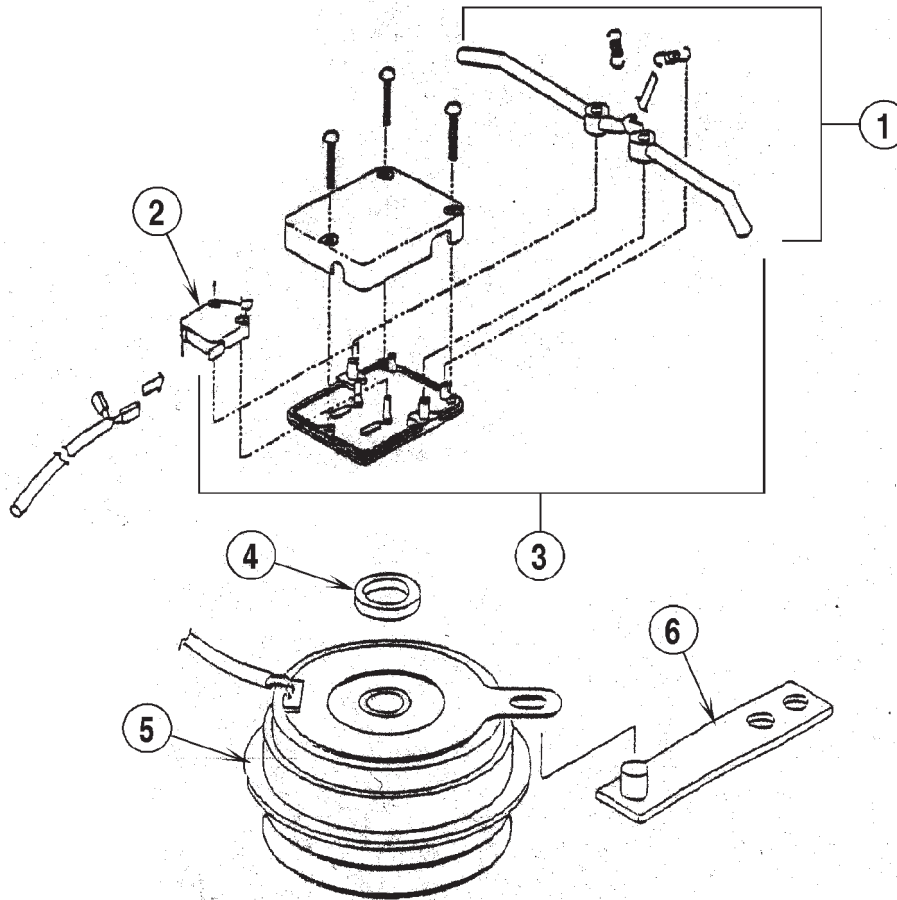

Item	Ref. No.	Qty	Description
1	56102573	1	Arm & Springs (2 each)
2	56102574	1	Switch (clutch)
3	56102575	1	Clutch Switch Assy Complete
4	56102576	1	Spacer
5	56102577	1	Electric Clutch
6	56102578	1	Clutch Arm

NOTE: For engine information not listed in the Standard Parts List, refer to the appropriate Engine Parts Manual.

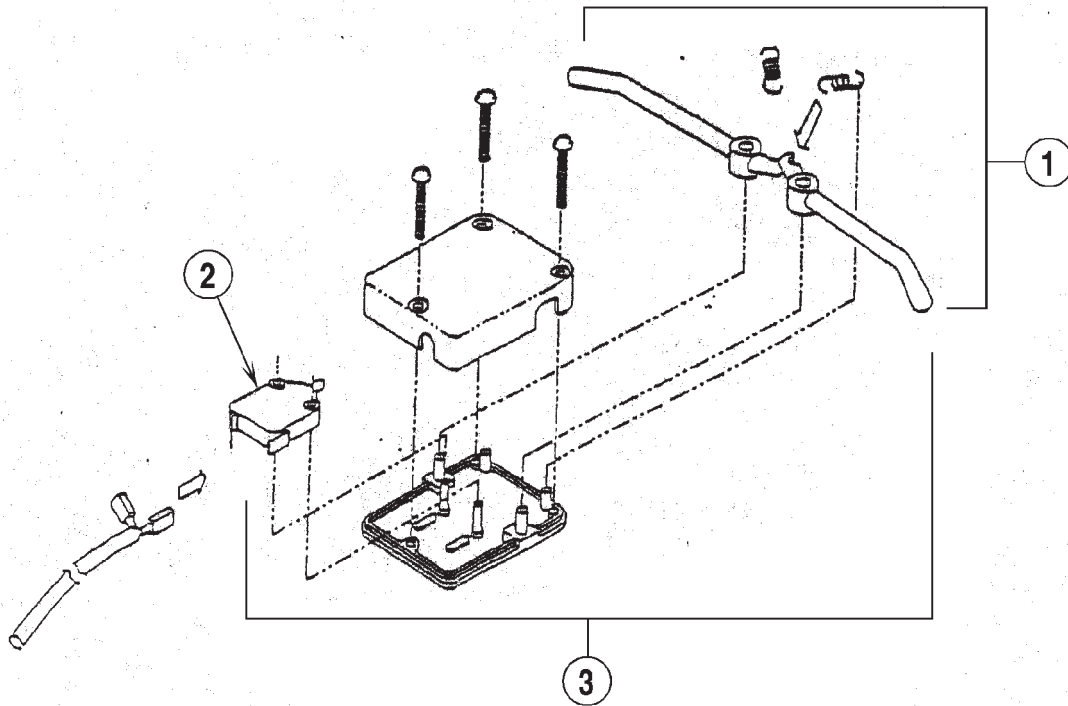

Item	Ref. No.	Qty	Description
1	56102573	1	Arm & Springs (2 each)
2	56102579	1	Switch (kill)
3	56102580	1	Kill Switch Assy Complete

NOTE: For engine information not listed in the Standard Parts List, refer to the appropriate Engine Parts Manual.

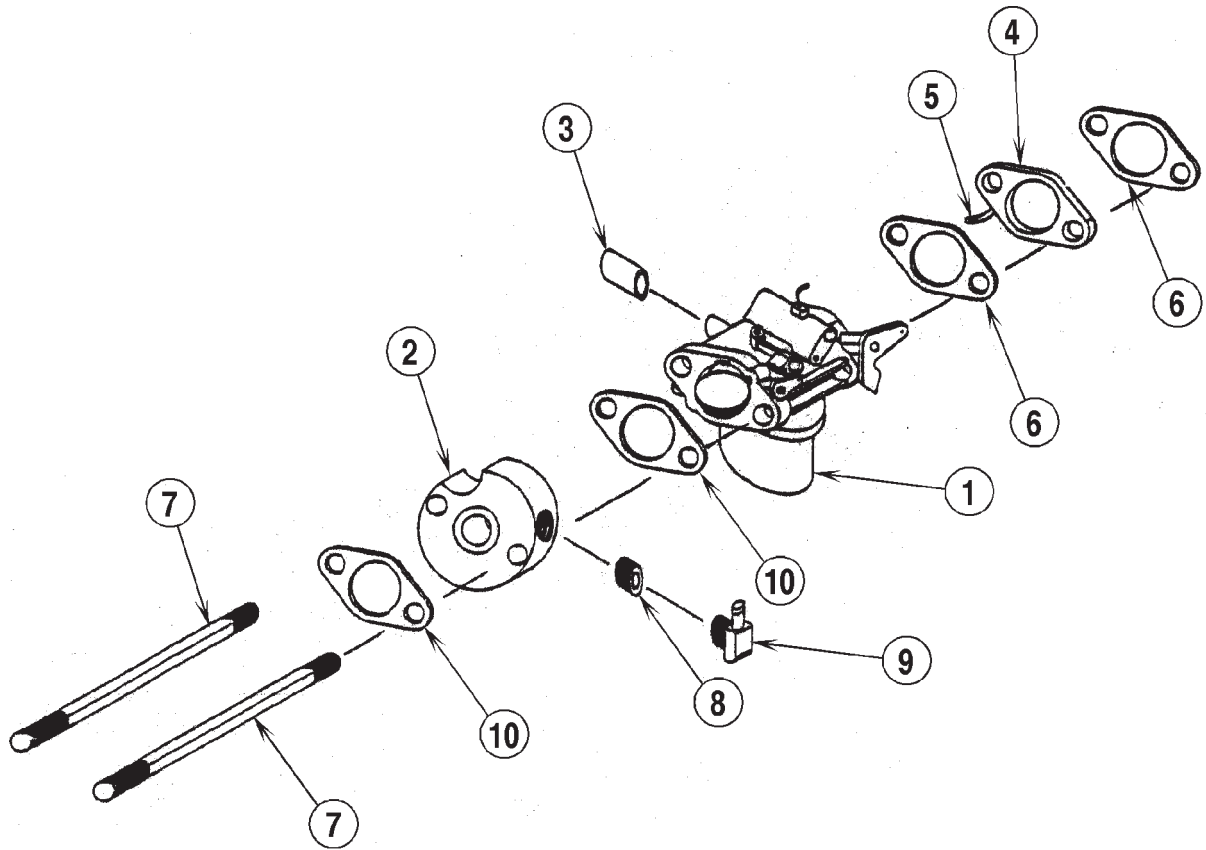

Item	Ref. No.	Qty	Description
1	56102584	1	Carburetor Assy
2	56102585	1	Fuel Load Block
3	56102586	1	Rubber Cap 1/4
4	56102587	1	Insulator
5	56102588	1	Vacuum Tube
6	56102589	2	Gasket Air Filter
7	56102590	2	Stud, M6 x 130
8	56102591	1	Brass Plug
9	56102592	1	Elbow, 3/8 x 1/4 MP
10	56102593	2	Gasket Air Filter

NOTE: For engine information not listed in the Standard Parts List, refer to the appropriate Engine Parts Manual.

FUEL LOAD BLOCK

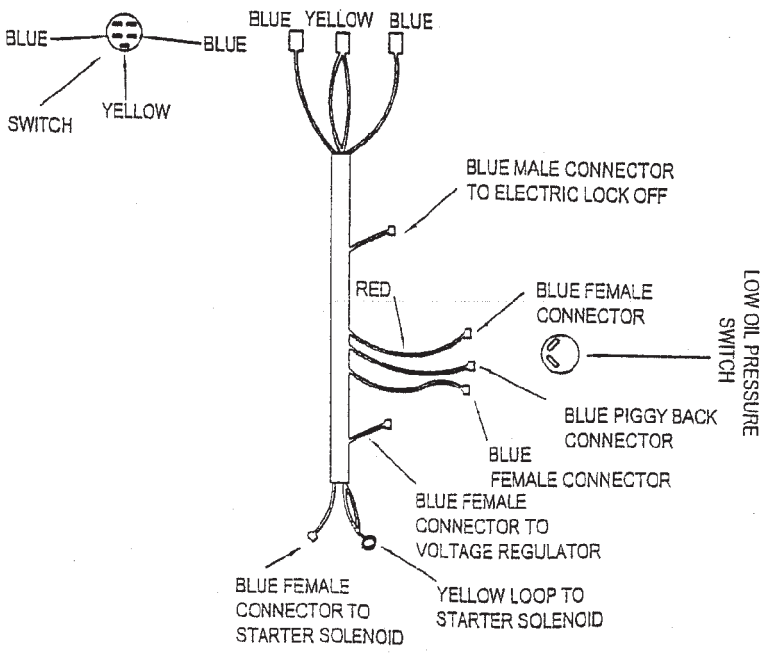
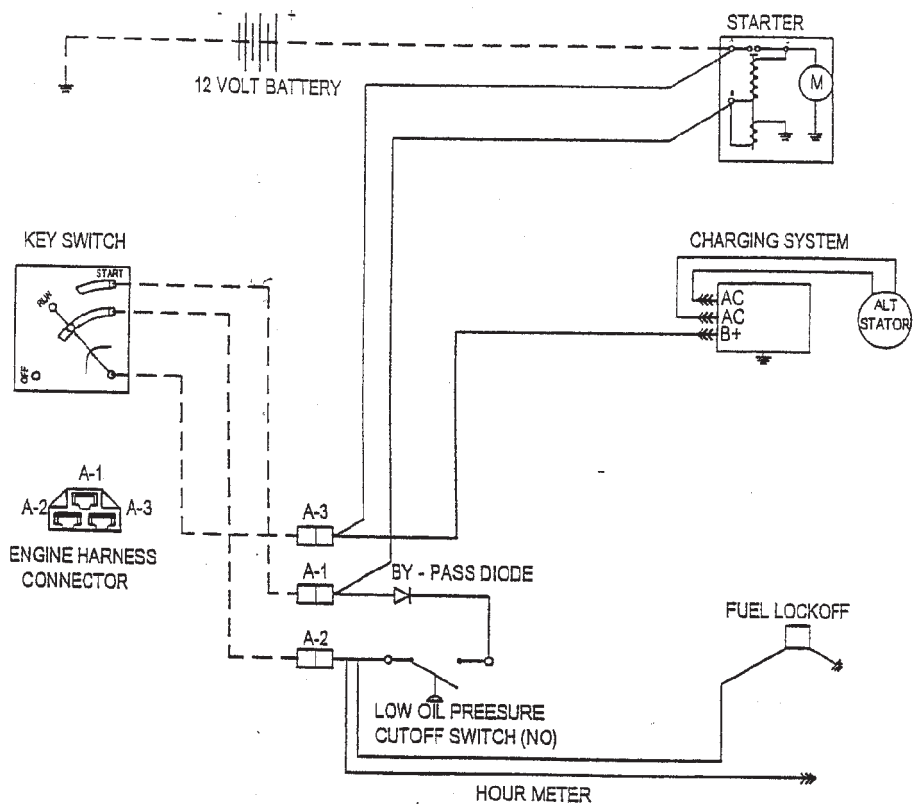

KENT
Simple. Clean.
14600 21st Avenue North
Plymouth, MN, 55447-3408
www.kenturoclean.com
Phone: 800-334-1083
Fax: 866-261-4779
©2005 Kent