

# SelectScrub™ 39

---

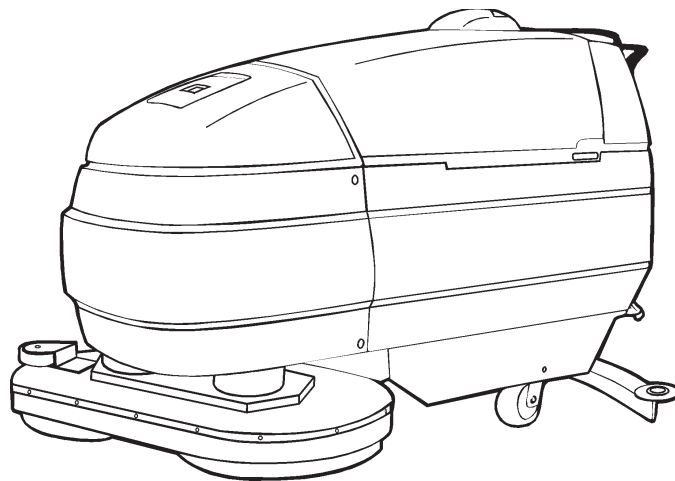

---

## PARTS LIST

### Kent MODEL 56637005



**KENT**  
**Euroclean**

*Working For A Cleaner World*

4/99 revised 10/03 FORM NO. 56042368 (083427P-1)

**RECOMMENDED SPARE PARTS**

99-4

**SelectScrub™ 39**

01-11

<b>Ref. No.</b>	<b>Qty</b>	<b>Description</b>
56035302	1	Hose, Squeegee Blk
56035129	1	Hose, Tank Blk
56035179	1	Hose, Dump Blk
56039135	2	Carbon Brush
56377001	2	Carbon Brush set for vac motor
56047484	1	Knob
56056632	1	Rubber, Squeegee Front
56056633	1	Rubber, Squeegee Rear
56056634	1	Rubber, Squeegee Backup
56056466	1	Gasket, Squeegee
56056793	1	Filter, Screen

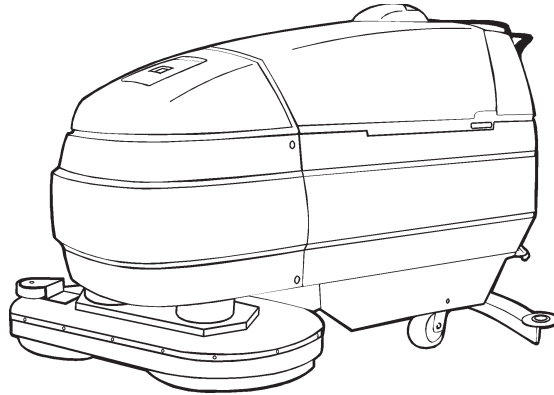

<b>DESCRIPTION</b>	<b>PAGE</b>
<b>SOLUTION TANK ASSEMBLY</b> .....	<b>2-3</b>
<b>RECOVERY TANK ASSEMBLY</b> .....	<b>4-5</b>
<b>BACK PANEL ASSEMBLY</b> .....	<b>6-7</b>
<b>SQUEEGEE ASSEMBLY</b> .....	<b>8-9</b>
<b>BRUSH HEAD ASSEMBLY</b> .....	<b>10-11</b>
<b>REAR COVER ASSEMBLY</b> .....	<b>12-13</b>
<b>BRUSH COVER ASSEMBLY</b> .....	<b>14-15</b>
<b>FRAME ASSEMBLY</b> .....	<b>16-17</b>
<b>CHASSIS ASSEMBLY</b> .....	<b>18-19</b>
<b>WIRING DIAGRAM</b> .....	<b>20</b>

**WHEN ORDERING PARTS**

- \* Use the 8 digit numbers from the "Ref. No." columns in this parts list.
- \* Specify the model and serial number of the machine.
- \* Use the space below to record the model and serial number for future reference.

Model \_\_\_\_\_ Serial No. \_\_\_\_\_

**SOLUTION TANK ASSEMBLY**

99-4

2

**SelectScrub™ 39**

00-2

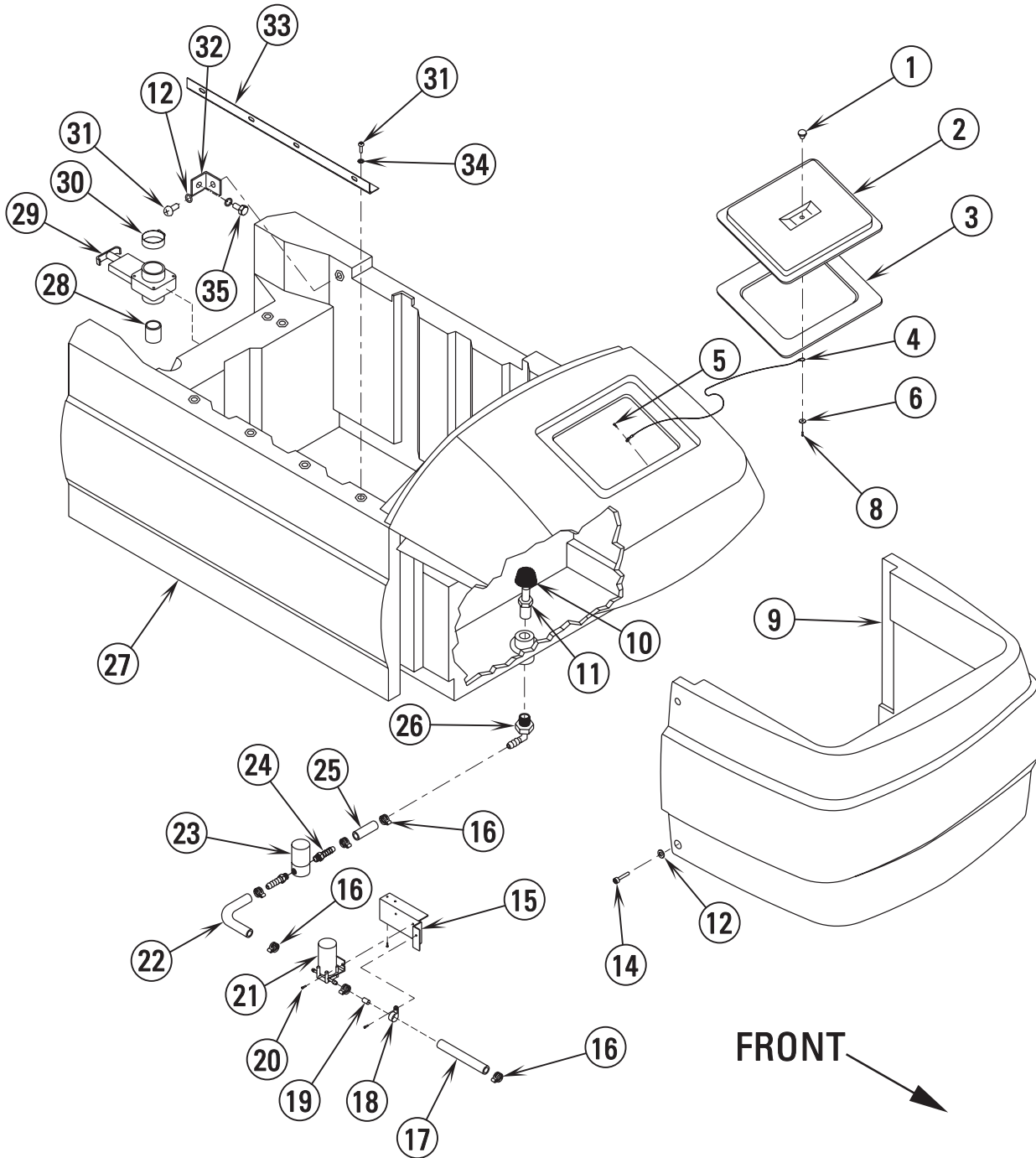

**FRONT** →

99-4	<b>SOLUTION TANK ASSEMBLY</b>		
03-10	<b>SelectScrub™ 39</b>		<b>3</b>

Item	Ref. No.	Qty	Description
	56035615	1	Assy, Solution Tank, Includes Items (1-8, 10-11, 26-30)
1	56048022	1	Knob, Thumb—Scr 10-24,Int.
2	56056250	1	Lid, Tank —DURASCRUB
3	56056379	1	Gasket, Foam —EXTR.RECOVERY
4	56053793	1	Wire Rope—.062 Dia x 10.50L
5	56009191	1	Scr Pan Phil Plastite 10-14 x .50
6	56009267	1	Wsh Flt .203ID.562OD.045T STL
7			<b>Intentionally Omitted</b>
8	56001993	1	Scr, Pan Phil 10-24 x .50
9	56056204	1	Cover, Front—Molded Autos Gray
10	56057209	1	Line Strainer—80 Micron,S.S.
11	56051207	1	Adptr, PP-HS—1/2MPT x 3/8HS, PLS
12	56003539	4	Wsh Flt .281ID.500OD.036T Stl
13			<b>Intentionally Omitted</b>
14	56001961	4	Scr Cap Soc HD—1/4-20 x 1.25 L
15	56056659	1	Bracket, Water Pump
16	56219932	6	Clamp, Hose—.625 MAX Dia, Worm
17	56052887	1	Tube, Vinyl—.375 x .625,18.00L,R
18	56051474	1	Clamp, Loop—.625 Closed ID, Nyl
19	56057688	1	Spacer, SS—.106 x .400, .50
20	56009030	5	Scr Pan Phil Thd Form 10-24 x .375L
21	56639470	1	Assy, Pump—12V,1GPM
22	56054293	1	Tube, Vinyl—.375 x .625,6.5L
23	56027145	1	Valve, Solenoid—24V
24	56054691	2	Adptr, PP-HS—3/8MPT x 3/8HS,BRS
25	56392277	1	Tube, Vinyl—.375 x .630, 5.0 L,R
26	56900033	1	Elbow, Barb
27	56645074	1	Tank, Solution
28	56056593	1	Tube, Plastic—1.58-1.50 Reducer
29	56055070	1	Valve, Slide—Shutoff,1.5Pipe,T
30	56440213	1	Clamp, Hose SAE #32
31	56001836	6	Scr Hex 1/4-20 x .62
32	56056857	2	Bracket, Angle—11GA, 1.50 Wide
33	56056514	1	Hinge, Butt—RS 056291, Black
34	56002098	4	Wsh, Flt SAE 1/4
35	56009019	2	Scr, Hex Thd Form 1/4-20 x .38



99-4	<b>RECOVERY TANK ASSEMBLY</b>			
03-10	<b>SelectScrub™ 39</b>			<b>5</b>

Item	Ref. No.	Qty	Description
	56035431	1	Assy, Recovery Tank, Includes Items (1-31, 35-46)
1	56009191	2	Scr Pan Phil Plastite 10-14 x .50
2	56056793	1	Filter, Screen—1.85ID,SS
3	56055494	1	Pipe, PVC—1.50 SCH40 x 6.00L
4	56329145	3	Clamp, Hose—2.25 Max Dia, Worm
5	56002917	3	Scr, Flt Phil SS 10-24 x 1
6	56002836	4	Nut, Hex Nyl Loc SS 10-24
7	56057076	1	Gasket, Support
8	56057075	1	Plate, SS—Vac Tank Support
9	56035326	1	Weldment, Support
10	56003015	2	Nut, Hex Jam SS 3/8-16
11	56035327	1	Weldment, Support—Rec Tank
12	56002959	4	Pin, Cot Hair SS .125 x Dia .50/.75
13	56035365	1	Weldment, Vac Tank—Support
14	56057026	1	Pin, Stl—3/8"OD,SS
15	56057187	1	Handle, Slide Valve—Service
16	56009316	6	Wsh, Flt .293 x .750 x .120
18	56009267	2	Wsh Flt .203ID.562OD.045T STL
19	56009011	2	Wsh, Int Shprf #10
20	56002147	2	Scr Pan Phil 10-32 x .50
21	56003537	3	Scr, Soc Shd .250 x .38 x 10-24
22	56057508	1	Bar, Stl—11GA,W/Slot, Plated
23	56057505	1	Bar, Stl—11GA, Plated
24	56035240	1	Assy, Vacuum Motor—36V, 3-Stage
25	56056764	3	Spacer, Phen—.265 x .500 x 3.156L
26			<b>Intentionally Omitted</b>
27	56377001	2	Carbon Brush Set for Vac Motor
28	56002740	3	Scr, Hex 1/4-20 x 4.00L
29	56035564	1	Assy, Hose—Blk, Cuffs & Elbow
30	56056676	1	Elbow, Pipe—RS 98402, Cut Off
31	56630382	1	Ring-Motor Mounting
32	56131601	4	Clamp, Hose—1.75 MAX Dia, Worm
33	56035129	1	Assy, Hose—Tank, 1.50 Dia, Blk
34	56035179	1	Assy, Hose—Dump, Blk, 1.50 Dia
35	56057671	1	Bracket, Steel—16GA.Taml Valve
36	56035160	1	Weldment, Drain—Recovery Tank
37	56054762	1	Gasket, Foam—.187 x 2.87 x 2.87
38	56057337	1	Valve, Slide
39	56053894	1	Fitting—Reducer,1.66-1.50,Pls
40	56057106	1	Tube, PVC—RS098403,4.500L
41	56057297	1	Tank, Recovery—Mach'd
42	56056758	1	Assy, Pipe Recovery
43	56057002	1	Switch, Float W/Wire
44	56056617	1	Wire Rope—.062Dia x 6.00L
45	56057890	1	Gasket—.375 x .375 x 36.00L
46	56057579	1	Lid, Domed—Durascrub, Clear

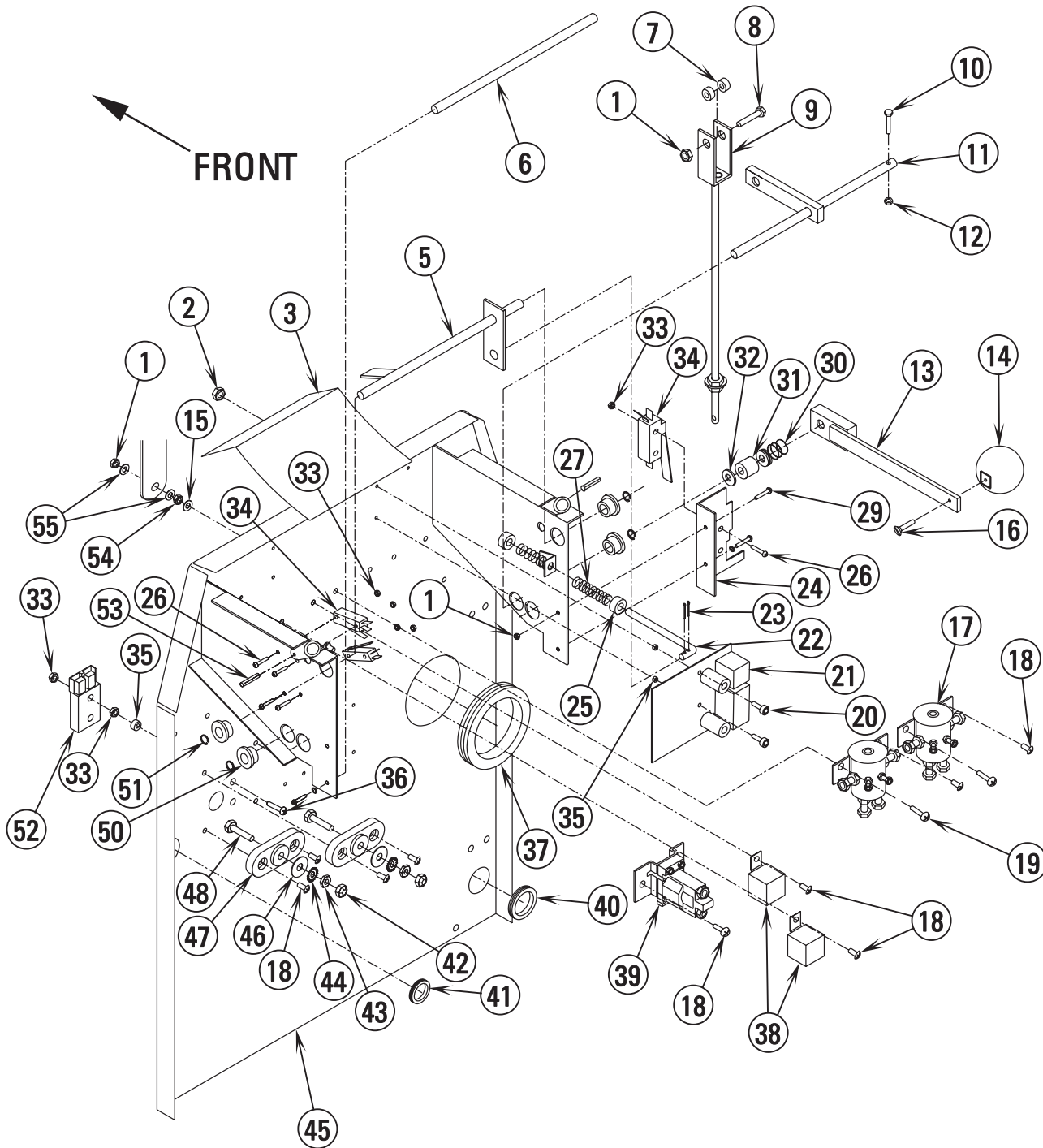

99-4	<b>BACK PANEL ASSEMBLY</b>			
03-10	<b>SelectScrub™ 39</b>			<b>7</b>

Item	Ref. No.	Qty	Description
1	56002708	4	Nut, Hex Nyl Loc 1/4-20,ZN PLT
2	56002808	2	Nut, Hex Nyl Loc 8-32,ZN
3	56026164	1	Insulator, Elec—Mylar,11.5 x 7
5	56035384	1	Weldment, Shaft Actuator
6	56057366	1	Rod, Stl—Support, Handle, KA-33SS
7	56050872	2	Spacer, Phen—.250 x .500, .375L
8	56001967	1	Scr Cap Hex Hd 1/4-20 x 1.75L
9	56035459	1	Assy, Squeegee Lift
10	56002495	1	Scr Flt Phil 10-24 x 1.50
11	56639618	1	Weldment, Squeegee 27SS, Plated
12	56002768	1	Nut Hex Nyl Loc 10-24
13	56639643	1	Weldment, Handle—Squeegee, Painted
14	56057391	1	Handle, Ball—Alum, 2.125 Dia
15			<b>Intentionally Omitted</b>
16	56002066	1	Scr Pan Phil 1/4-20 x .625
17	56026713	2	Solenoid, DPDT—Switch, 36V
18	56003603	12	Scr, Pan Phil Thd Form 1/4-20 x .375
19	56002825	1	Scr Pan Phil 1/4-20 x 1.25L
20	56001868	2	Scr, Pan Phil 8-32 x 1.00
21	56212261	1	Control—DC, Autos, Crts, 36V
22	56053296	1	Rod, Stl—.312 Dia., 6.00 Long
23	56002166	2	Pin, Cotter—.094 x .750 Long
24	56644683	1	Bracket—Arm Stop
25	56048987	2	Collar-Centering Spring
26	56002858	6	Scr Pan Phil 6-32 x 1.00L
27	56056597	2	Spring, Comp .480D 2.75L .045WD
28			<b>Intentionally Omitted</b>
29	56002066	3	Scr Pan Phil 1/4-20 x .625
30	56057388	1	Spring, Comp .975D .88 L .112WD
31	56057517	1	Spacer, Nylon—.50ID,.710D,.39T
32	56001879	3	Wsh, Flt SAE 1/2
33	56002830	8	Nut, Hex Nyl Loc 6-32
34	56026603	3	Switch, Lvr—SPDT, 20A, 125-250V
35	56057428	4	Spacer, Alum .187 x .375, .375L
36	56002670	2	Scr Pan Phil 6-32 x 1.50L
37	56054845	1	Grommet—3.00ID, 3.50MHD,.12PA
38	56026180	2	Relay, Power—24VDC,40/30A,SPDT
39	56026504	1	Solenoid—Switch, SPNO, 36VDC
40	56056672	1	Grommet—2"ID x 2.44MHD x .12PA
41	56055434	1	Grommet 1.0ID, 1.25MHD,.125PA
42	56003472	2	Nut, Hex Nyl Loc—5/16-18
43	56009086	2	Nut, Hex Jam 5/16-18,Zn Plt
44	56009052	2	Wsh, Int Shprf 5/16
45	56035463	1	Weldment, Back Panel
46	56004221	2	Wsh Flt .344ID1.00OD.036T Stl
47	56057872	2	Insulator Main Terminal
48	56001834	2	Scr Cap Hex Hd 5/16-18 x 1.25L
50	56027131	4	Bearing, Flange .500ID.750OD.500W
51	56003264	4	Ring, Ret Ext Type E
52	56027152	1	Assy, Charger Plug—2 CNDCT
53	56002734	2	Pin, Roll—.312 DIA,1.000L
54	56003145	1	Nut, Hex—1/4-20,SS
55	56009316	2	Wsh Flt .293 x .750 x .120

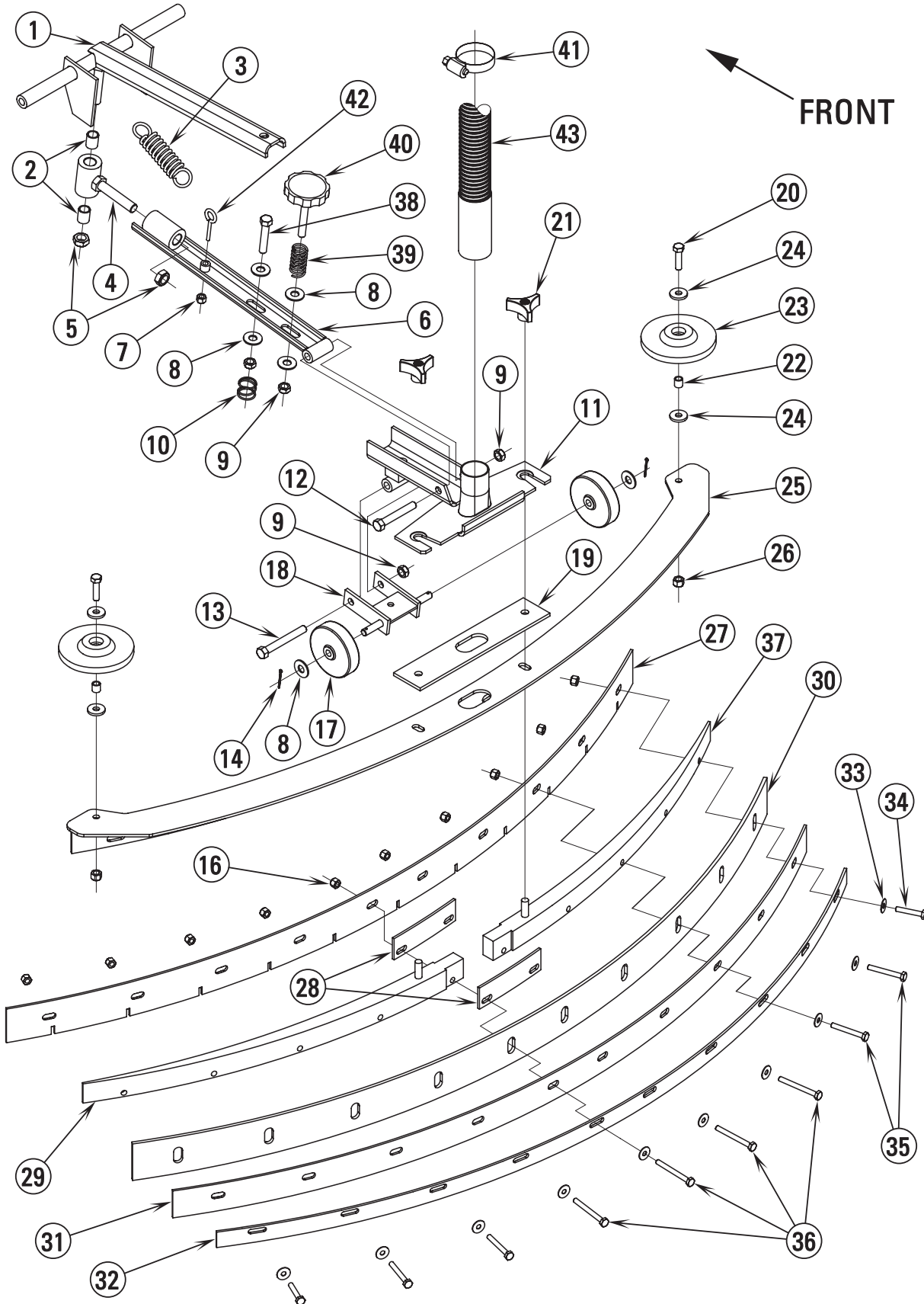

99-4	<b>SQUEEGEE ASSEMBLY</b>		
03-10	<b>SelectScrub™ 39</b>		<b>9</b>

Item	Ref. No.	Qty	Description
	56035099	1	Assy, Squeegee, Includes Items (16, 19-37)
	56035140	1	Assy, Squeegee Linkage, Includes Items (1-18, 38-42)
	56039567	1	Set, Squeegee Blade, Includes Items (27, 30-31)
1	56035139	1	Weldment, Squeegee Lift
2	56027171	2	Bearing, Sleeve .500ID, .625OD, .750W
3	56051136	1	Spring, Ext .750D 2.92L .104WD
4	56035150	1	Weldment, Pivot—Squeegee
5	56002843	2	Nut, Hex Nyl Loc Thin 1/2-13
6	56035137	1	Weldment, Squeegee Bar
7	56002708	1	Nut, Hex Nyl Loc 1/4-20
8	56002055	6	Wsh, Flt Std 3/8
9	56002841	4	Nut, Hex Nyl Loc-Thin 3/8-16
10	56056808	1	Spring, Comp .970D .750L .072WD
11	56035138	1	Weldment, Squeegee Bracket
12	56001873	1	Scr Cap Hex Hd 3/8-16-2.50L
13	56002204	1	Scr Cap Hex Hd 3/8-16X3.00L
14	56002038	2	Pin, Cotter—.094 x 1.00 Long
15			<b>Intentionally Omitted</b>
16	56002491	10	Nut, Hex Nyl Loc SS 1/4-20
17	56057193	2	Wheel, Plastic—3"OD, 3/8" Bore
18	56034172	1	Weldment, Bracket—Squeegee Wheel
19	56056466	1	Gasket, Squeegee—.187 x 2, 9.75L
20	56001834	2	Scr Cap Hex Hd 5/16-18 x 1.25L
21	56057935	2	Knob, 3-Lobe
22	56053699	2	Spacer, Stl—.312 x .437, .43L
23	56053720	2	Wheel—4.00DIA, .438Bore, .688HB
24	56009122	4	Wsh, Flt .344 x .938 x .125
25	56035101	1	Weldment, Squeegee
26	56002701	2	Nut, Hex Nyl Loc 5/16-18, Zn Plt
27	56056632	1	Rubber, Squeegee—Front
28	56056461	2	Clamp, Squeegee—11GA, 5.00L
29	56056432	1	Spacer, Squeegee—Left
30	56056633	1	Rubber, Squeegee—Rear
31	56056634	1	Rubber, Squeegee—Backup
32	56056635	1	Strap, Squeegee
33	56009025	10	Wsh Flt .266 x .750 x .036
34	56001833	2	Scr Hex 1/4-20 x 1.50
35	56001874	4	Scr Hex 1/4-20 x 2.00
36	56001855	4	Scr Hex 1/4-20 x 2.50
37	56056431	1	Spacer, Squeegee—Right
38	56002470	1	Scr Hex Thd to Hd 3/8-16 x 2.00
39	56056585	1	Spring, Comp .845D 1.75L .085WD
40	56635868	1	Assy, Knob—Adjustment, 3/8-16
41	56131601	1	Clamp, Hose—1.75 Max Dia, Worm
42	56009220	1	Bolt, Eye 1/4-20 x 1.00
43	56035302	1	Assy, Hose—Squeegee, 1.5 Dia, Blk

BRUSH HEAD ASSEMBLY

99-4

10

SelectScrub™ 39

03-10

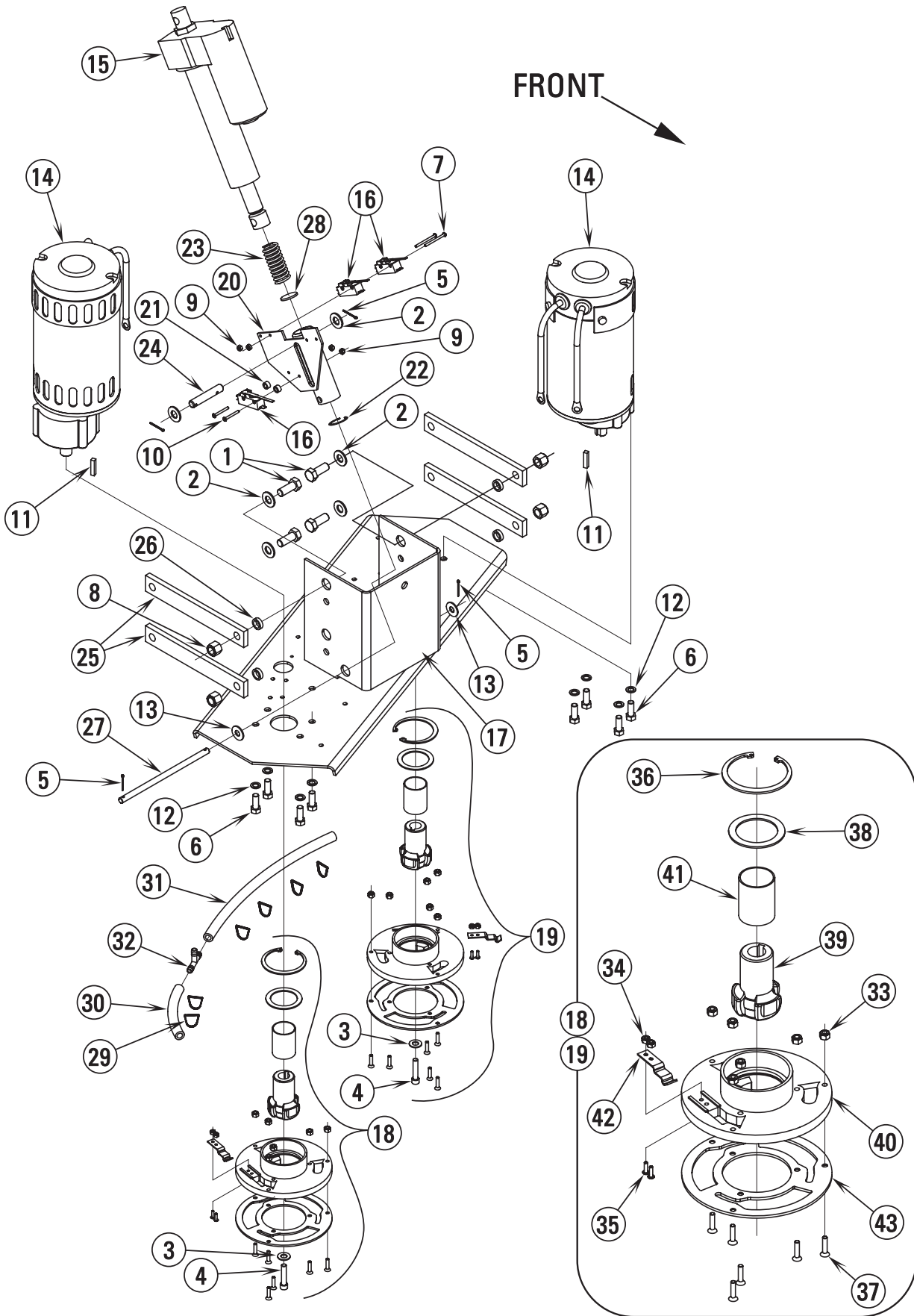

99-4	<b>BRUSH HEAD ASSEMBLY</b>			
03-10	<b>SelectScrub™ 39</b>			<b>11</b>

Item	Ref. No.	Qty	Description
	56035493	1	Assy, Brush Head, Includes Items (1-32)
1	56001831	4	Scr, Hex Hd 1/2-13 x 1.25
2	56001879	6	Wsh, Fit SAE 1/2
3	56002063	2	Wsh, Fit SAE 3/8
4	56002201	2	Scr, Soc Hd 5/16-18 x 1.50
5	56002529	4	Pin, Cotter 1/8 x 1
6	56002663	8	Scr, Hex Hd 3/8-16 x 1.00
7	56002692	2	Scr, Pan Phil 6-32 x 1.75
8	56002770	4	Nut, Hex Nyl Loc 1/2-13
9	56002830	4	Nut, Hex Nyl Loc 6-32
10	56003049	2	Scr, Pan Phil 6-32 x 1.25
11	56003245	2	Key, Sq .25 x 1.19
12	56009047	8	Wsh, Fit .391 x .625 x .060
13	56005219	2	Washer, Flat
14	56024360	2	Assembly, Motor and Gearbox
15	56024368	1	Actuator, DC
16	56026603	3	Switch, Lever – SPDT, 20A
17	56035130	1	Weldment, Brush Head 39
18	56035131	1	Assembly, Drive Hub, Right (includes items 33-43)
19	56035132	1	Assembly, Drive Hub, Left (includes items 33-43)
20	56035547	1	Weldment, Actuator Tube
21	56046425	2	Spacer, Phenolic
22	56046762	1	Ring, Retaining, Int.
23	56054427	1	Compression Spring
24	56056155	1	Pin, Actuator
25	56056254	4	Bar, Steel 20/26 Auto
26	56056473	4	Spacer, .75 OD .531 ID
27	56056474	1	Shaft, Steel
28	56056639	1	Plate, Steel
29	56478246	6	Cable, Tie
30	56644845	1	Tube, Vinyl
31	56755327	1	Tube, Vinyl
32	56046944	1	Tee, Hose – 3/8 x 3/8 x 3/8, Plastic
33	56002836	6	Nut, Hex Nyl Loc SS 10-24
34	56002907	2	Nut, Hex Nyl Loc SS 6-32
35	56003026	2	Scr, Pan Phil SS 6-32 x .50
36	56003525	1	Ring, Ret, Int. Type HO SS
37	56003630	6	Scr, Fit Phil SS 10-24 x 0.88
38	56009283	1	Washer, Flat SS
39	56056445	1	Shaft, Drive, Brush
40	56056447	1	Hub, Drive, Right
	56056446	1	Hub, Drive, Left
41	56056464	1	Tube, Stainless
42	56056468	1	Clip, Retaining, Brush Lug
43	56057159	1	Plate, Brush Retainer, Right
	56057160	1	Plate, Brush Retainer, Left
**	56027135	2	Polypropylene Brush
**	56020398	2	Grit Brush
**	56020439	2	Pad Holder

\*\* = Optional

REAR COVER ASSEMBLY

99-4

12

SelectScrub™ 39

00-2

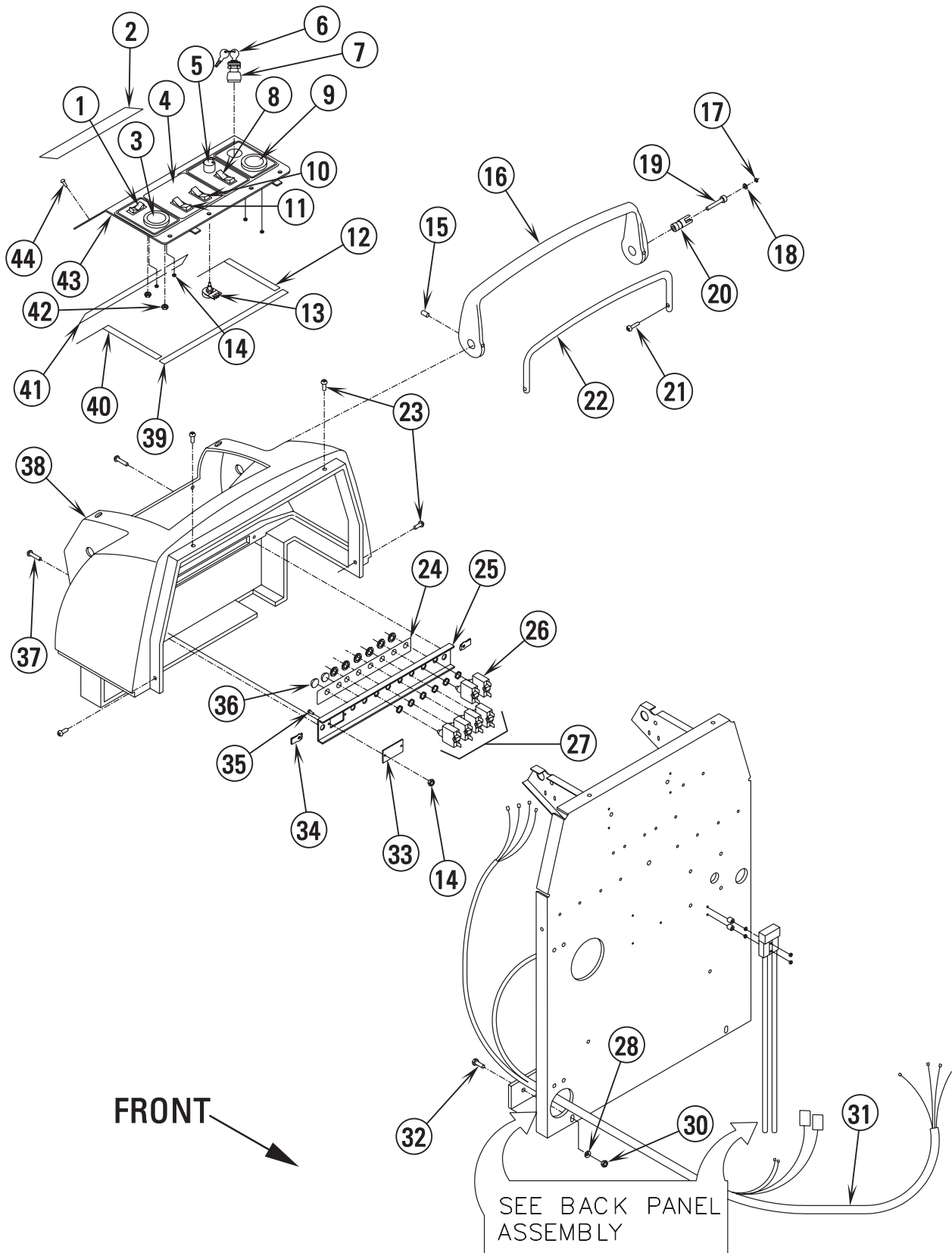

99-4	<b>REAR COVER ASSEMBLY</b>			
01-2	<b>SelectScrub™ 39</b>			<b>13</b>

Item	Ref. No.	Qty	Description
1	56026046	1	Switch, Rocker—DPDT
2	56057836	1	Label—Warning, Automatics
3	56026131	1	Ammeter, DC—0-75A, Round, 2.0 Dia
4	56057614	1	Label—Instr Panel
5	56056596	1	Knob, Plastic—Black,.92Dia x .95
6	56057243	1	Key, Automatics—for P/N 56441538
7	56441538	1	Starter-Switch-Locking
8	56026130	1	Switch, Rocker—DPDT, On/Off/On
9	56027161	1	Voltmeter—27-45 VDC, Round
10	56026129	1	Switch, Rocker—DPST, Off/On/(On)
11	56027241	1	Switch, Rocker—SPDT, On/Off Momt
12	56057308	1	Gasket—.125 x .500, 8.656L, Left
13	56026243	1	Potentiometer Assembly
14	56002830	6	Nut, Hex Nyl Loc 6-32
15	56001826	2	Scr, Soc Set Loc 5/16-18 x .500
16	56056594	1	Handle, Painted Actuator
17	56056761	2	Ring, Retaining—Int, .500Bore, N5000
18	56003539	2	Wsh, Flt .281ID.500OD.036T Stl
19	56002242	2	Scr Soc Hd 1/4-20 x 1.50
20	56056359	2	Shaft, Stl—.750Dia, 1.75L
21	56002145	2	Scr Pan Phil 1/4-20 x .50L
22	56056595	1	Handle, Stl—.625Dia, Painted
23	56009043	4	Scr Pan Phil Thd Form 10-24 x .750L
24	56057430	1	Label—Circuit Breaker, SS
25	56056499	1	Panel, Circuit Breaker
26	56387316	2	Circuit Breaker—10Amp
27	56454423	4	Circuit Breaker—30AMP, Scr Trm
28	56001939	2	Wsh Flt SAE 5/16
29			<b>Intentionally Omitted</b>
30	56002025	2	Nut, Hex—5/16-18
31	56027172	1	Harness, Wire—SS/Brush Pause
32	56002667	2	Scr Hex 5/16-18 x .750
33	56644681	1	Plate, Stl—Breaker Panel, Paint
34	56009289	2	Nut, U Multi-Thread 1/4-20
35	56223188	2	Scr Mach Pan Hd 6-32 x .50
36	56323560	2	Plug, Dome—.500Dia, Blk Plastic
37	56002507	2	Scr Pan Phil 1/4-20 x .75
38	56057362	1	Cover, Rear—Mach, Auto
39	56057306	1	Gasket—.125 x .500, 13.75L, Top
40	56057309	1	Gasket—.125 x .500, 8.656R
41	56057310	1	Gasket—.125 x .500, 12.75L
42	56002491	1	Nut, Hex Nyl Loc SS 1/4-20
43	56057343	1	Panel, Instr
44	56009191	6	Scr Pan Phil Plastite 10-14 x .50

**BRUSH COVER ASSEMBLY**

99-4

14

**SelectScrub™ 39**

03-10

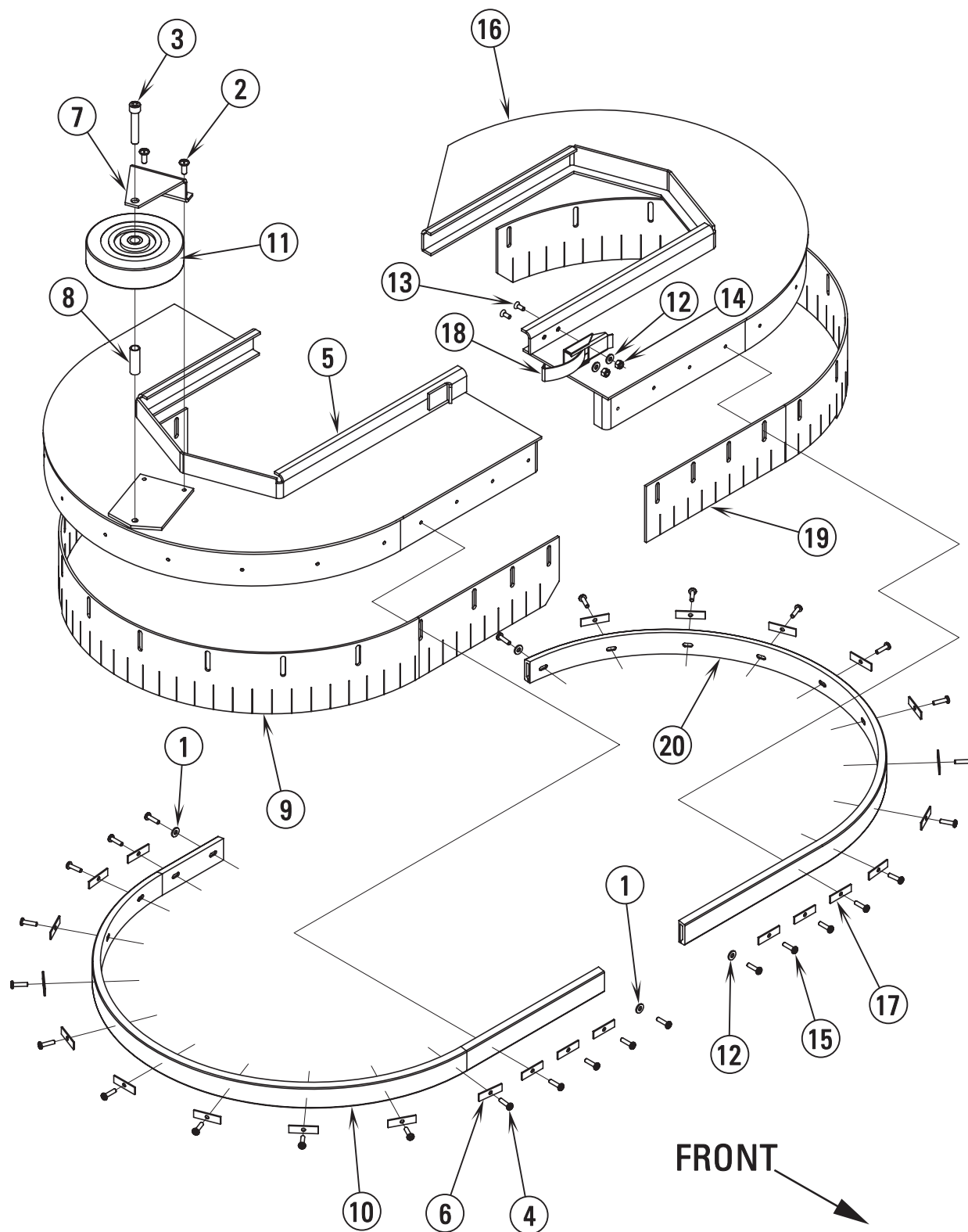

99-4	<b>BRUSH COVER ASSEMBLY</b>		
03-10	<b>SelectScrub™ 39</b>		<b>15</b>

Item	Ref. No.	Qty	Description
	56035214	1	Assy, Brush Cover, Right, Includes Items (1-11)
1	56001954	2	Wsh, Flt SAE #10
2	56002066	2	Scr, Pan Phil 1/4-20 x .62
3	56002133	1	Scr Soc Hd 3/8 -16 x 2.00
4	56009209	15	Scr, Pan Phil Thd Form 10-24 x 1.00
5	56035112	1	Weldment, Brush cover R.H. 39
6	56052006	13	Strap, .063 x .437 x 1.50
7	56056120	1	Bracket, Brush Head Guide
8	56056684	1	Spacer, Steel
9	56056730	1	Guard, Splash R.H. 39
10	56056731	1	Channel, Rubber R.H. 39
11	56161691	1	Wheel
	56035213	1	Assy, Brush Cover, Left, Includes Items (12-20)
12	56001954	4	Wsh, Flt SAE #10
13	56002178	2	Scr, Flt Phil 10-24 x .50
14	56002768	2	Nut, Hex Nyl Loc 10-24
15	56009209	13	Scr, Pan Phil Thd Form 10-24 x 1.00
16	56035113	1	Weldment, Brush Cover L.H. 39
17	56052006	11	Strap, .063 x .437 x 1.50
18	56054306	1	Clamp, Toggle Latch
19	56056668	1	Guard, Splash L.H. 39
20	56056729	1	Channel, Rubber, L.H. 39

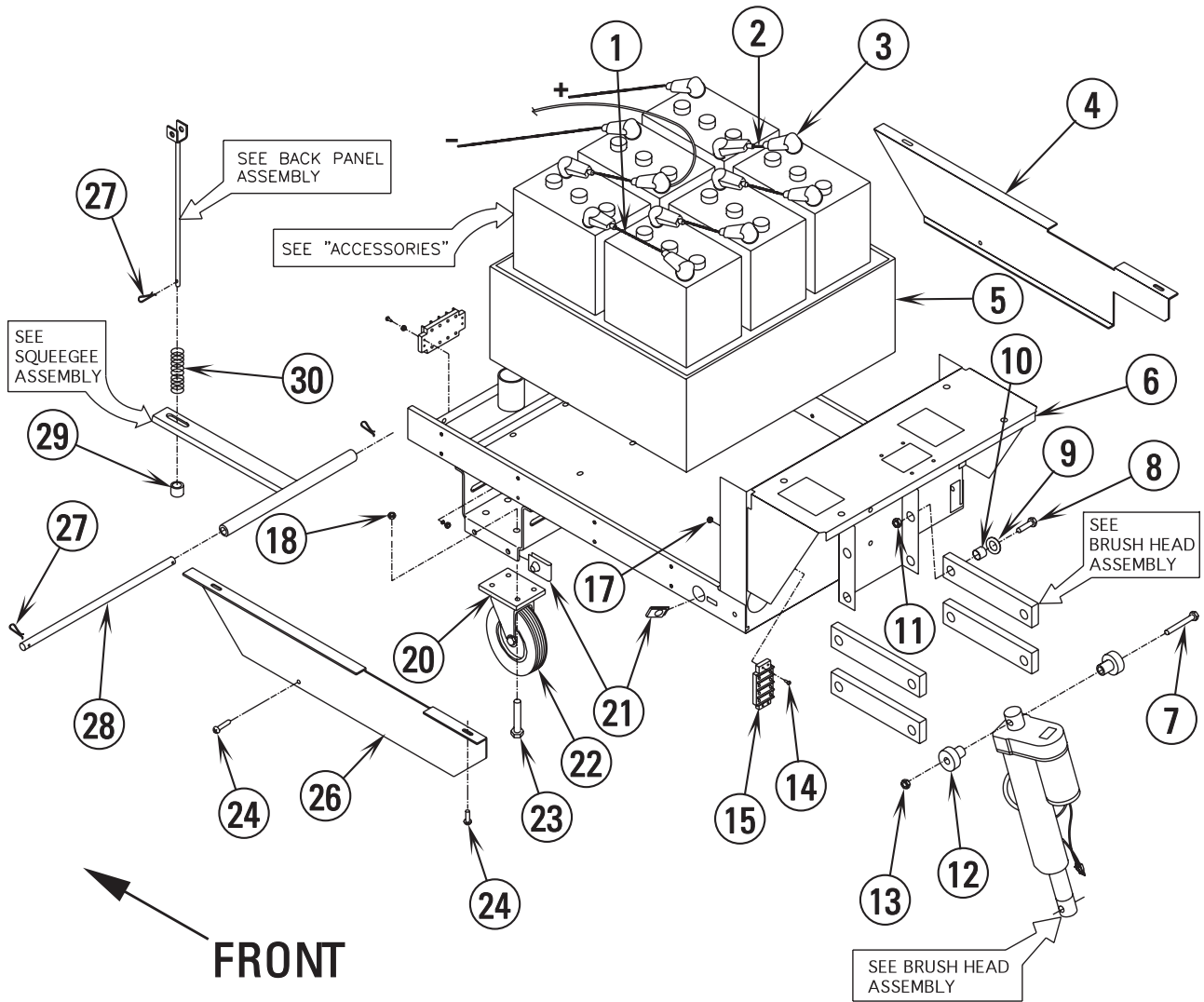

99-4	<b>FRAME ASSEMBLY</b>		
02-1	<b>SelectScrub™ 39</b>		<b>17</b>

Item	Ref. No.	Qty	Description
1	56025274	1	Assy, Wire— 6GA, Blk, 14.0L, Rings
2	56637492	4	Assy, Wire— 6GA, Blk, 10.2L, Rings
3	56372673	12	Boot, Battery Post
*	56478246	12	Cable Tie
4	56056357	1	Skirt, Lower Left
5	56053534	1	Box, Battery
6	56035089	1	Weldment—Upper Chassis
7	56001892	1	Scr Hex 3/8-16 x 2.75L
8	56001831	4	Scr Hex 1/2-13 x 1.25L
9	56001879	4	Wsh, Flt SAE 1/2
10	56056473	4	Spacer, Stl—.531 x .750, .218L
11	56002770	4	Nut, Hex Nyl Loc 1/2-13,Zn Plt
12	56054502	2	Bushing, Sleeve—.377ID.498OB1.00FLNG
13	56002769	1	Nut, Hex Nyl Loc 3/8-16
14	56002674	8	Scr Pan Phil 10-24 x 1.00
15	56026111	2	Terminal Block—4 Term, 50 Amp
16	56009011	8	Wsh, Int Shprf #10
17	56002768	8	Nut, Hex Nyl Loc 10-24,Zn Plt
18	56002769	8	Nut, Hex Nyl Loc 3/8-16
19			<b>Intentionally Omitted</b>
20	56039563	2	Kit, Wheel & Axle—for 56440450
21	56009289	4	Nut, U Multi-Thread 1/4-20
22	56440450	2	Caster, Swivel—5.0 Dia, 700 lb
23	56002947	8	Scr Hex Loc 3/8-16 x 1.00
24	56002066	6	Scr Pan Phil 1/4-20 x .625
25			<b>Intentionally Omitted</b>
26	56056358	1	Skirt, Lower—Right
27	56002959	3	Pin, Lock—.125 Dia Wire
28	56056371	1	Shaft, Stl—.375 Dia, 14.62L
29	56056683	1	Spacer, Stl—.391 x .625, .500L
30	56056618	1	Spring, Comp .845D 3.50L .100WD

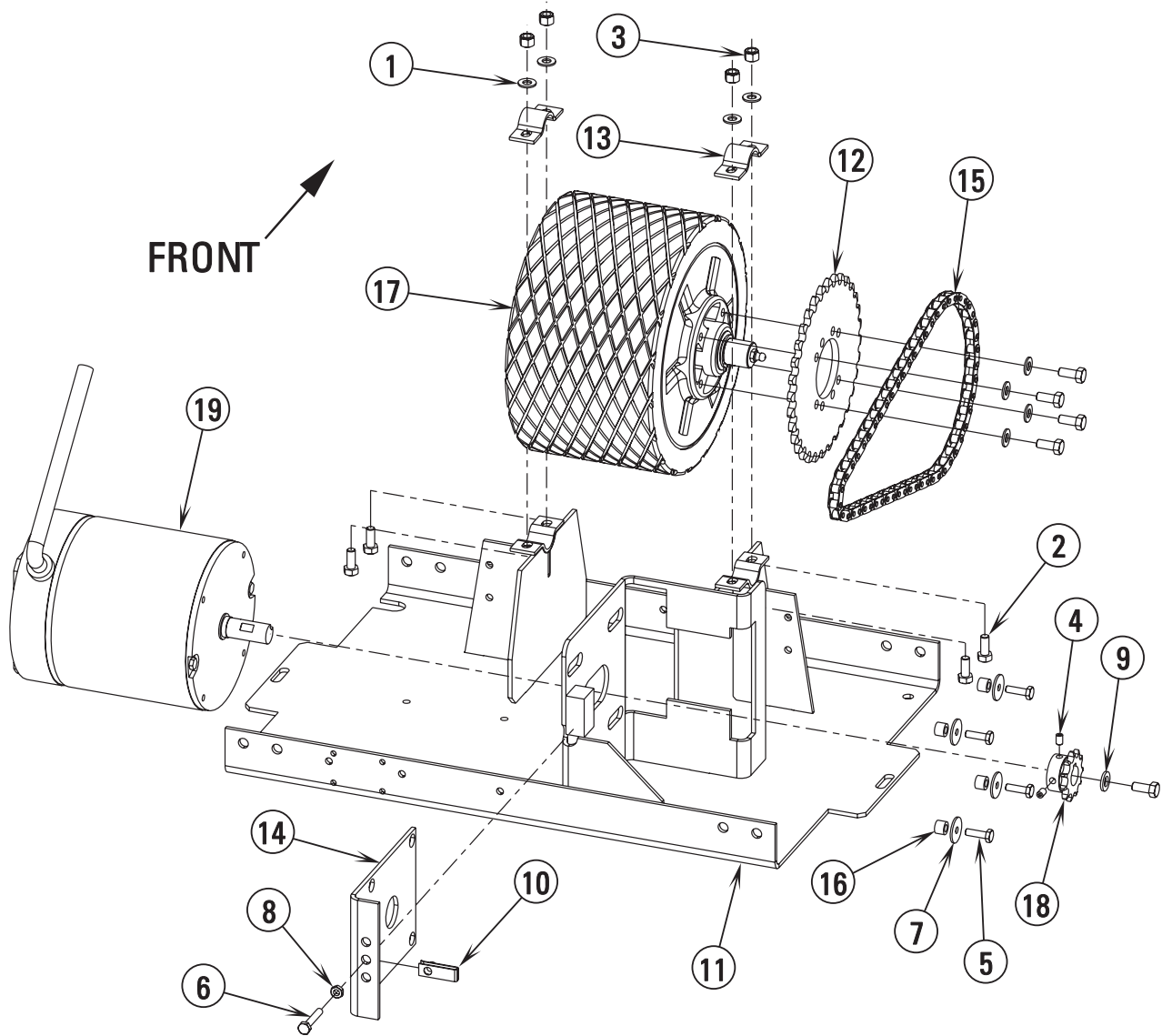

99-4	<b>CHASSIS ASSEMBLY</b>		
02-4	<b>SelectScrub™ 39</b>		<b>19</b>

Item	Ref. No.	Qty	Description
	56639722	1	Assy, Lower Chassis, Includes Items (1-19)
1	56001939	8	Wsh, Flt SAE 5/16
2	56002667	9	Scr, Hex Hd 5/16-18 x .75
3	56002701	4	Nut, Hex Nyl Loc 5/16-18
4	56002930	2	Scr Soc Set Loc 1/4-20 x .38
5	56002960	4	Scr, Hex Loc 1/4-20 x .88
6	56003125	1	Scr, Hex Thd/Hd SS 1/4-20 x 1.50
7	56009060	4	Wsh, Flt SS .260 x 1.00 x .074
8	56009087	1	Nut, Hex Jam 1/4-20
9	56009214	1	Wsh, Flt .406 x .750 x .090
10	56009289	1	Nut, U Multi-Thread 1/4-20
11	56035608	1	Weldment, Base - 36V Motor
12	56051376	1	Sprocket
13	56056327	2	Clamp, Axle
14	56057833	1	Bracket, Tension - Traction Drive
15	56057899	1	Chain, #40 - 32
16	56100856	4	Spacer
17	56648312	1	Wheel & Axle Assembly
18	56741122	1	Sprocket
19	56741124	1	Motor, 36V Drive

AUTOMOTIVE STYLE RELAY CONNECTION DETAIL

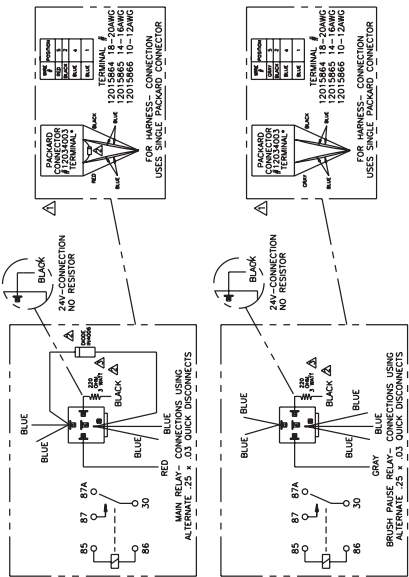

- △ MAIN RELAY CONNECTIONS CAN BE MADE WITH INDIVIDUAL QUICK DISCONNECTS AS SHOWN.
- △ INSULATE COMPONENTS WITH HEAT SHRINKABLE TUBING OR EQUIVALENT INSULATION.
- △ ONLY 36V SYSTEMS REQUIRE THE RESISTOR ASSEMBLY: (P/N 026203-1)

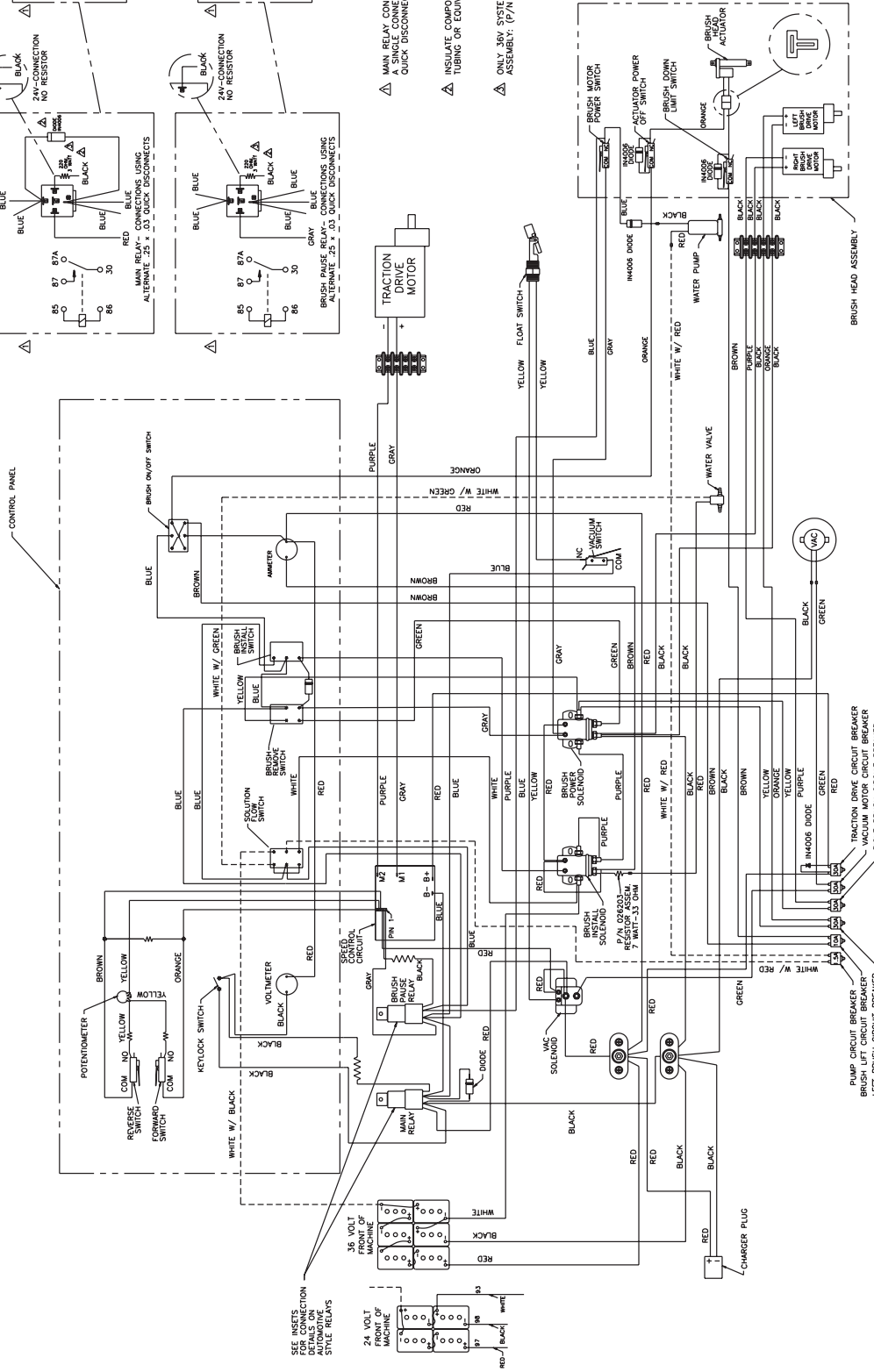

SEE INSERTS FOR CONNECTIONS FOR AUTOMOTIVE STYLE RELAYS

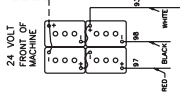



**KENT**  
**Euroclean**

*Working For A Cleaner World*

Kent/Euroclean  
14600 21st Avenue North  
Plymouth, MN, 55447-3408  
[www.kenteuroclean.com](http://www.kenteuroclean.com)  
Phone: 800-334-1083  
Fax: 866-261-4779  
©2003 Printed in the U.S.A.