

# Sprite Plus™ 12, 16 / WD 200 SERIES

## MicroVac™ 6, 12, 16

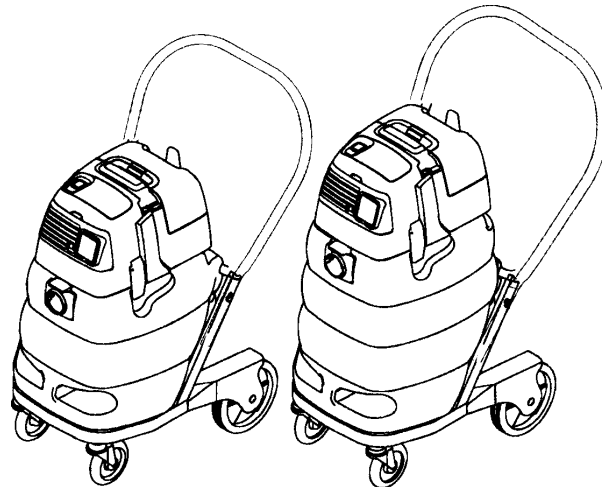
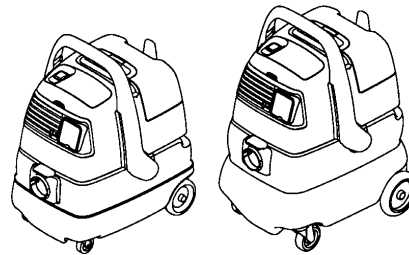

### **PARTS LIST**

Advance MODELS 9054316010, 9054416010

Kent MODELS 9053104010, 9054304010, 9054404010, 9053122010, 9054323010, 9054424010

Euroclean MODELS 9053007010, 9054407010



**Nilfisk  
Advance**

*setting standards*

822 9370 000 ED.5 12/2000  
**56042397**

LINE DRAWING

2

MOTOR TOP

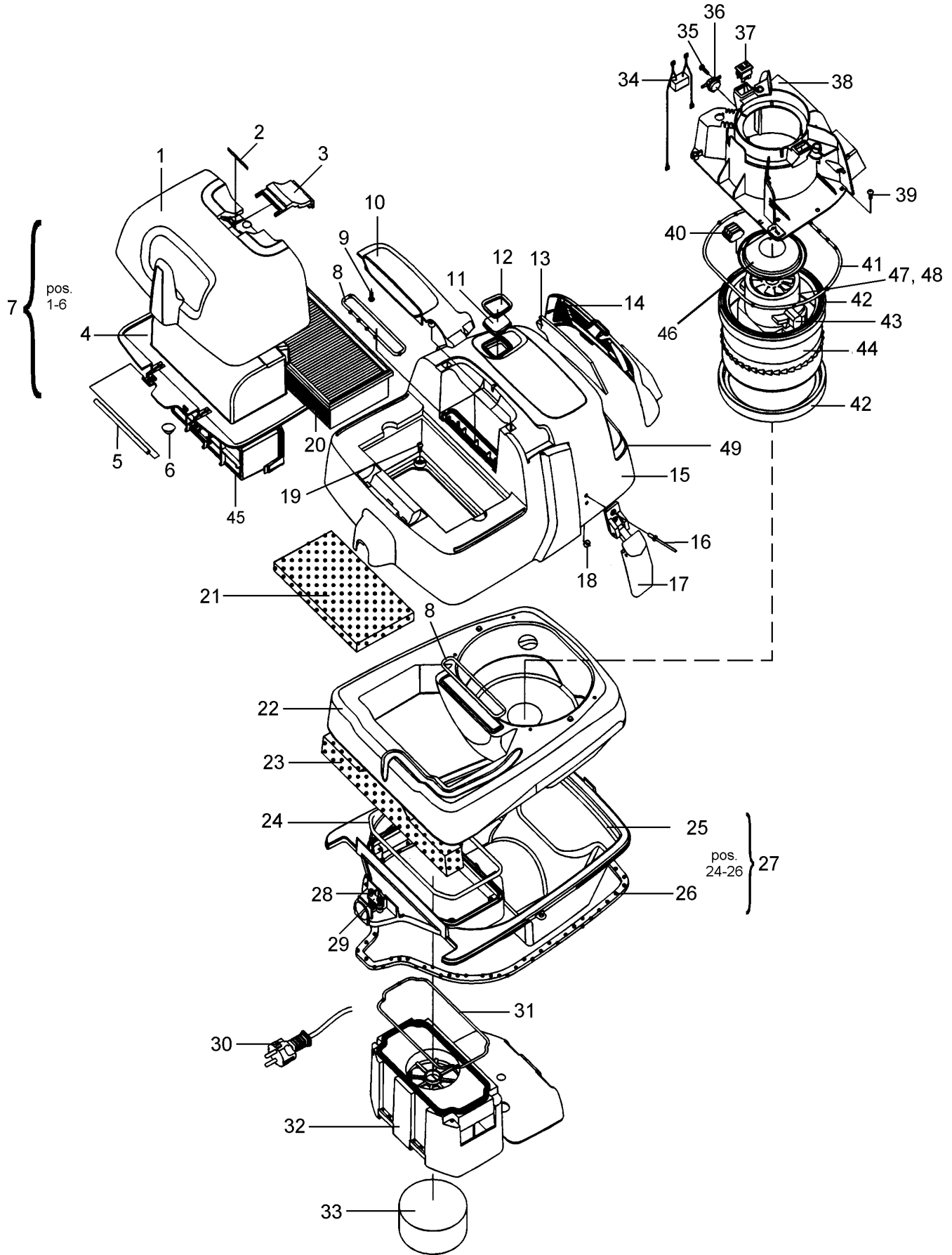

**PART NUMBER**

**MOTOR TOP**

**3**

No.	Qty.	Part No.	Description
1	1	140 7236 000	Filter lid, blue
	1	140 7236 030	Filter lid, grey
2	1	140 7250 000	Spring
3	1	140 7234 000	Lock arm, blue
	1	140 7234 030	Lock arm, grey
4	1	140 7235 000	Filter holder, blue
	1	140 7235 030	Filter holder, grey
5	1	140 6936 000	Shaft
6	1	140 7372 000	Rubber foot
7	1	140 7219 000	Blue filter lid cpl. pos.1-6
	1	140 7219 030	Grey filter lid cpl. pos 1-6
8	2	140 7249 000	Sealing ring
9	2	140 9214 070	Screw
10	1	140 7221 000	Handle, blue
	1	140 7221 030	Handle, grey
11	1	140 7222 040	Protection hood
12	1	140 7223 000	Locking ring
13	1	140 7231 000	Exhaust filter
14	1	140 7232 000	Filter holder, blue
	1	140 7232 010	Filter holder, blue UL approved
	1	140 7232 050	Filter holder, grey UL approved
15	1	140 7214 060	Cover, blue, WD 245, 260, Euroclean logo screen printed
	1	140 7214 090	Cover, blue, WD 215,225, Eurocelan logo screen printed
	1	140 7214 070	Cover, blue UL -material, KENT 245/260 logo screen printed
	1	140 7214 030	Cover, blue UL-material, KENT 215/225 logo screen printed
	1	140 7214 080	Cover, blue UL-material, WD 260 Euroclean logo screen printed
	1	140 7214 110	Cover, blue UL-material, WD 215 Euroclean logo screen printed
	1	140 7214 140	Cover, grey Nilfisk 215, 225
	1	140 7214 150	Cover, grey Nilfisk 245/260
	1	140 7214 160	Cover, grey UL material, Sprite 12,16
	>>	140 7994 000	Cover with latches, blue Euroclean
	>>	140 7994 010	Cover with latches, blue UL Kent
	>>	140 7994 020	Cover with latches, blue UL Euroclean
	>>	140 7994 030	Cover with latches, grey no logo
	>>	140 7994 040	Cover with latches, grey UL no logo
16	4	140 5694 050	Rivet, only for WD 245/60, Sprite 12,16, KENT 12,16
17	2	140 7608 000	Latch, only for WD 245/60, Sprite 12,16, KENT 12,16
18	4	734 4852 010	Washer
19	4	140 9214 150	Screw
20	1	140 7215 000	Filter
21	1	140 7258 000	Pre-filter
22	1	140 7212 000	Motor box
23	1	140 7253 000	Diffusor
24	1	140 7302 010	Sealing ring
25	1	140 7211 000	Middle part
26	1	140 0061 030	Gasket
27	1	140 7248 000	Middle part cpl. pos.24-26
28	2	140 9214 040	Screw
29	1	056 1014 060	Anti strain clip
	>>	140 6560 000	Anti strain clip, UL-approved
30	1		Chord , see table
31	1	140 7249 010	Sealing ring
32	1	140 7611 000	Float basket
33	1	140 8231 000	Float body
34	1	140 7620 000	Suppressor
35	1	140 6843 000	Screw Torx RTS ST
36	1	140 7058 000	Thermal protection
37	1	140 7217 000	Switch
38	1	140 7213 000	Cover
39	4	140 9214 070	Screw
40	1	140 7244 000	Connector
41	1	140 7225 000	O-ring
42	2	140 6909 000	Sealing ring
43	2		Carbon brush. See table
44	1		Fan unit. See table
45	1	140 7271 020	Hepa-filter (Accessorie)
46	1	140 7209 000	Extract damping
47	1	735 2136 800	Toothed plate connector (Grounded US-versions only)
48	1	140 7300 030	Screw (Grounded US-versions only)
49	1	140 7771 000	Decal, Nilfisk WD-series
	1	140 7828 000	Decal, Advance Sprite

**WHEN ORDERING PARTS ALWAYS STATE:**

- \* The 10 digit part numbers
- \* Quantity,
- \* Specify the model and serial numbers of the machine.

**For Electrical details also:**

- \* Voltage
- \* Wattage

**Sticker/Decal (only for grey covers)**

- Nilfisk WD-series
- 140 7771 000
- Advance Sprite
- 140 7828 000

LINE DRAWING

4

MOTOR TOP, LARGER FLOAT SYSTEM

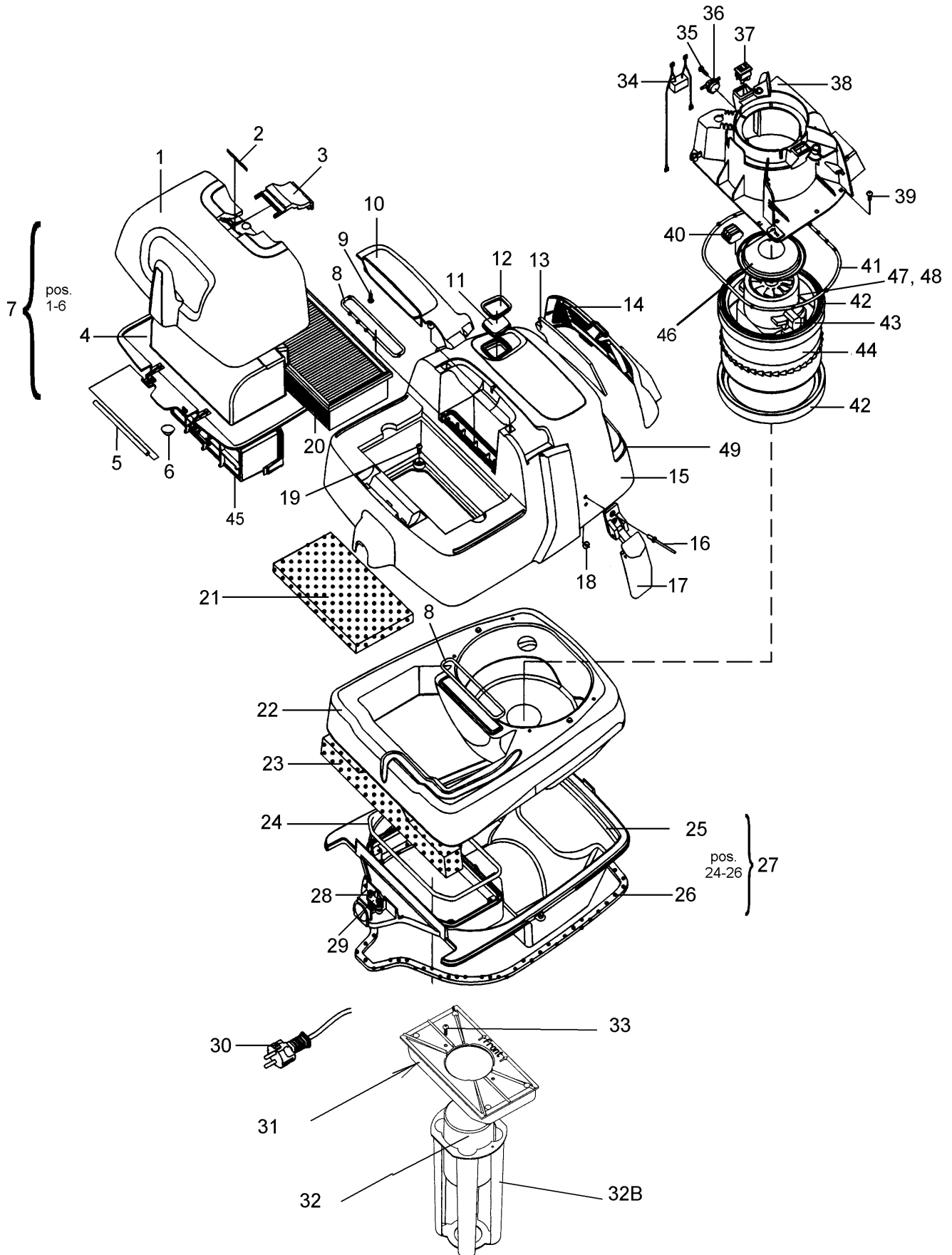

**PART NUMBER****MOTOR TOP, LARGER FLOAT SYSTEM****5**

No.	Qty.	Part No.	Description
1	1	140 7236 000	Filter lid, blue
	1	140 7236 030	Filter lid, grey
2	1	140 7250 000	Spring
3	1	140 7234 000	Lock arm, blue
	1	140 7234 030	Lock arm, grey
4	1	140 7235 000	Filter holder, blue
	1	140 7235 030	Filter holder, grey
5	1	140 6936 000	Shaft
6	1	140 7372 000	Rubber foot
7	1	140 7219 000	Blue filter lid cpl. pos.1-6
	1	140 7219 030	Grey filter lid cpl. pos 1-6
8	2	140 7249 000	Sealing ring
9	2	140 9214 070	Screw
10	1	140 7221 000	Handle, blue
	1	140 7221 030	Handle, grey
11	1	140 7222 040	Protection hood
12	1	140 7223 000	Locking ring
13	1	140 7231 000	Exhaust filter
14	1	140 7232 000	Filter holder, blue
	1	140 7232 010	Filter holder, blue UL approved
	1	140 7232 050	Filter holder, grey UL approved
15	1	140 7214 060	Cover, blue, WD 245, 260, Euroclean logo screen printed
	1	140 7214 090	Cover, blue, WD 215,225, Eurocelan logo screen printed
	1	140 7214 070	Cover, blue UL -material, KENT 12,16 , logo screen printed
	1	140 7214 030	Cover, blue UL-material, KENT 6, logo screen printed
	1	140 7214 080	Cover, blue UL-material, WD 260 Euroclean logo screen printed
	1	140 7214 110	Cover, blue UL-material, WD 215 Euroclean logo screen printed
	1	140 7214 140	Cover, grey Nilfisk 215, 225
	1	140 7214 150	Cover, grey Nilfisk 245/260
	1	140 7214 160	Cover, grey UL material, Sprite 12,16
	>>	140 7994 000	Cover with latches, blue Euroclean
	>>	140 7994 010	Cover with latches, blue UL Kent
	>>	140 7994 020	Cover with latches, blue UL Euroclean
	>>	140 7994 030	Cover with latches, grey no logo
	>>	140 7994 040	Cover with latches, grey UL no logo
16	4	140 5694 050	Rivet, only for WD 245/60, Sprite 12,16, KENT 12,16
17	2	140 7608 000	Latch, only for WD 245/60, Sprite 12,16, KENT 12,16
18	4	734 4852 010	Washer
19	4	140 9214 010	Screw, Torx T20
20	1	140 7215 000	Filter
21	1	140 7258 010	Pre-filter
22	1	140 7212 000	Motor box
23	1	140 7253 000	Diffusor
24	1	140 7302 010	Sealing ring
25	1	140 7211 000	Middle part
26	1	140 0061 030	Gasket
27	1	140 7248 000	Middle part cpl. pos.24-26
28	2	140 9214 040	Screw
29	1	056 1014 060	Anti strain clip
	>>	140 6560 000	Anti strain clip, UL-approved
30	1		Chord , see table
31	1	140 7631 000	Basket carrier
32	1	140 7948 000	Float body
32B	1	140 7944 000	Float basket
33	2	140 9214 000	Screw Torx 40x14 stainless
34	1	140 7620 000	Suppressor
35	1	140 6843 000	Screw Torx RTS ST
36	1	140 7058 000	Thermal protection
37	1	140 7217 000	Switch
38	1	140 7213 000	Cover
39	4	140 9214 070	Screw
40	1	140 7244 000	Connector
41	1	140 7225 000	O-ring
42	2	140 6909 000	Sealing ring
43	2		Carbon brush. See table
44	1		Fan unit. See table
45	1	140 7271 020	Hepa-filter (Accessorie)
46	1	140 7209 000	Extract damping
47	1	735 2136 800	Toothed plate connector (Grounded US-versions only)
48	1	140 7300 030	Screw (Grounded US-versions only)
49	1	140 7771 000	Decal, Nilfisk WD-series
	1	140 7828 000	Decal, Advance Sprite
		140 7529 010	<b>Float system kit cpl.</b>

**WHEN ORDERING PARTS ALWAYS STATE:**

- \* The 10 digit part numbers
- \* Quantity,
- \* Specify the model and serial numbers of the machine.

**For Electrical details also:**

- \* Voltage
- \* Wattage

**PARTS LIST****6****CORD, FAN UNIT FOR WD, MICROVAC & SPRITE**

<b>PROD NR</b>	<b>VOLT</b>	<b>CORD</b>	<b>CARBON BRUSH</b>	<b>FAN UNIT</b>
<b>WD 215</b>				
905 3001	220-240V	093 1054 020	140 7169 000	140 7154 000
905 3002	220-240V	011 2504 220	140 7169 000	140 7154 000
905 3003	220-240V	140 6643 020	140 7169 000	140 7154 000
905 3004 Kent	110-120V	140 3859 050	140 7169 010	140 7605 000
905 3005	220-240V	140 6668 020	140 7169 000	140 7154 000
905 3006	100V	140 6702 000	140 7169 010	140 7154 010
905 3007	110-120V	140 3859 050	140 7169 010	140 7605 000
905 3008	110-120V	140 3608 010	140 7169 010	140 7605 000
905 3018	220-240V	093 1054 020	140 7169 000	140 7154 000
905 3019	220-240V	011 2504 220	140 7169 000	140 7154 000
905 3020	220-240V	140 6643 020	140 7169 000	140 7154 000
905 3021	220-240V	140 6668 020	140 7169 000	140 7154 000
905 3022	100V	140 6702 000	140 7169 010	140 7154 010
905 3023	110-120V	140 3608 010	140 7169 010	140 7605 000

**WD 225, KENT Microvac 6**

905 3101	220-240V	093 1054 020	140 7169 000	140 7154 000
905 3102	220-240V	011 2504 220	140 7169 000	140 7154 000
905 3103	220-240V	140 6643 020	140 7169 000	140 7154 000
905 3104 Kent	110-120V	140 3859 080	140 7169 010	140 7605 000
905 3105	220-240V	140 6668 020	140 7169 000	140 7154 000
905 3106	100V	140 6702 000	140 7169 010	140 7154 010
905 3108	110-120V	140 3608 010	140 7169 010	140 7605 000
905 3109	220-240V	093 1054 020	140 7169 000	140 7154 000
905 3110	220-240V	011 2504 220	140 7169 000	140 7154 000
905 3111	220-240V	140 6643 020	140 7169 000	140 7154 000
905 3112	220-240V	140 6668 020	140 7169 010	140 7154 000
905 3113	100V	140 6702 000	140 7169 010	140 7154 010
905 3114	110-120V	140 3608 010	140 7169 010	140 7605 000

**PARTS LIST****CORD, FAN UNIT FOR WD, MICROVAC & SPRITE****7**

PROD NR	VOLT	CORD	CARBON BRUSH	FAN UNIT
<b>WD 245, KENT Microvac 12, Advance Sprite 12</b>				
905 4301	220-240V	093 1054 020	140 7169 000	140 7154 000
905 4302	220-240V	011 2504 220	140 7169 000	140 7154 000
905 4303	220-240V	140 6643 020	140 7169 000	140 7154 000
905 4304 Kent	110-120V	140 3859 080	140 7169 010	140 7605 000
905 4305	220-240V	140 6668 020	140 7169 000	140 7154 000
905 4306	100V	140 6702 000	140 7169 010	140 7154 010
905 4307	110-120V	140 3859 080	140 7169 010	140 7605 000
905 4308	110-120V	140 3608 010	140 7169 010	140 7605 000
905 4309	220-240V	093 1054 020	140 7169 000	140 7154 000
905 4310	220-240V	093 1054 020	140 7169 000	140 7154 000
905 4311	220-240V	011 2504 220	140 7169 000	140 7154 000
905 4312	220-240V	140 6643 020	140 7169 000	140 7154 000
905 4313	220-240V	140 6668 020	140 7169 000	140 7154 000
905 4314	100V	140 6702 000	140 7169 010	140 7154 010
905 4315	110-120V	140 3608 010	140 7169 010	140 7605 000
905 4316 Sprite	110-120	140 3859 080	140 7169 010	140 7605 000
905 4317	220-240V	093 1054 020	140 7169 000	140 7154 000

**WD 260, KENT Microvac 16, Advance Sprite 16**

905 4401	220-240V	093 1054 020	140 7169 000	140 7154 000
905 4402	220-240V	011 2504 220	140 7169 000	140 7154 000
905 4403	220-240V	140 6643 020	140 7169 000	140 7154 000
905 4404 Kent	110-120V	140 3859 010	140 7169 010	140 7605 000
905 4405	220-240V	140 6668 020	140 7169 000	140 7154 000
905 4406	100V	140 6702 000	140 7069 010	140 7154 010
905 4407	110-120V	140 3859 080	140 7169 010	140 7605 000
905 4408	110-120V	140 3608 010	140 7169 010	140 7605 000
905 4409	220-240V	093 1054 020	140 7169 000	140 7154 000
905 4410	220-240V	093 1054 020	140 7169 000	140 7154 000
905 4411	220-240V	011 2504 220	140 7169 000	140 7154 000
905 4412	220-240V	140 6643 020	140 7169 000	140 7154 000
905 4413	220-240V	140 6668 020	140 7169 000	140 7154 000
905 4414	100V	140 6702 000	140 7069 010	140 7154 010
905 4415	110-120V	140 3608 010	140 7169 010	140 7605 000
905 4416 Sprite	110-120V	140 3859 080	140 7169 010	140 7605 000
905 4417	220-240V	093 1054 020	140 7169 000	140 7154 000

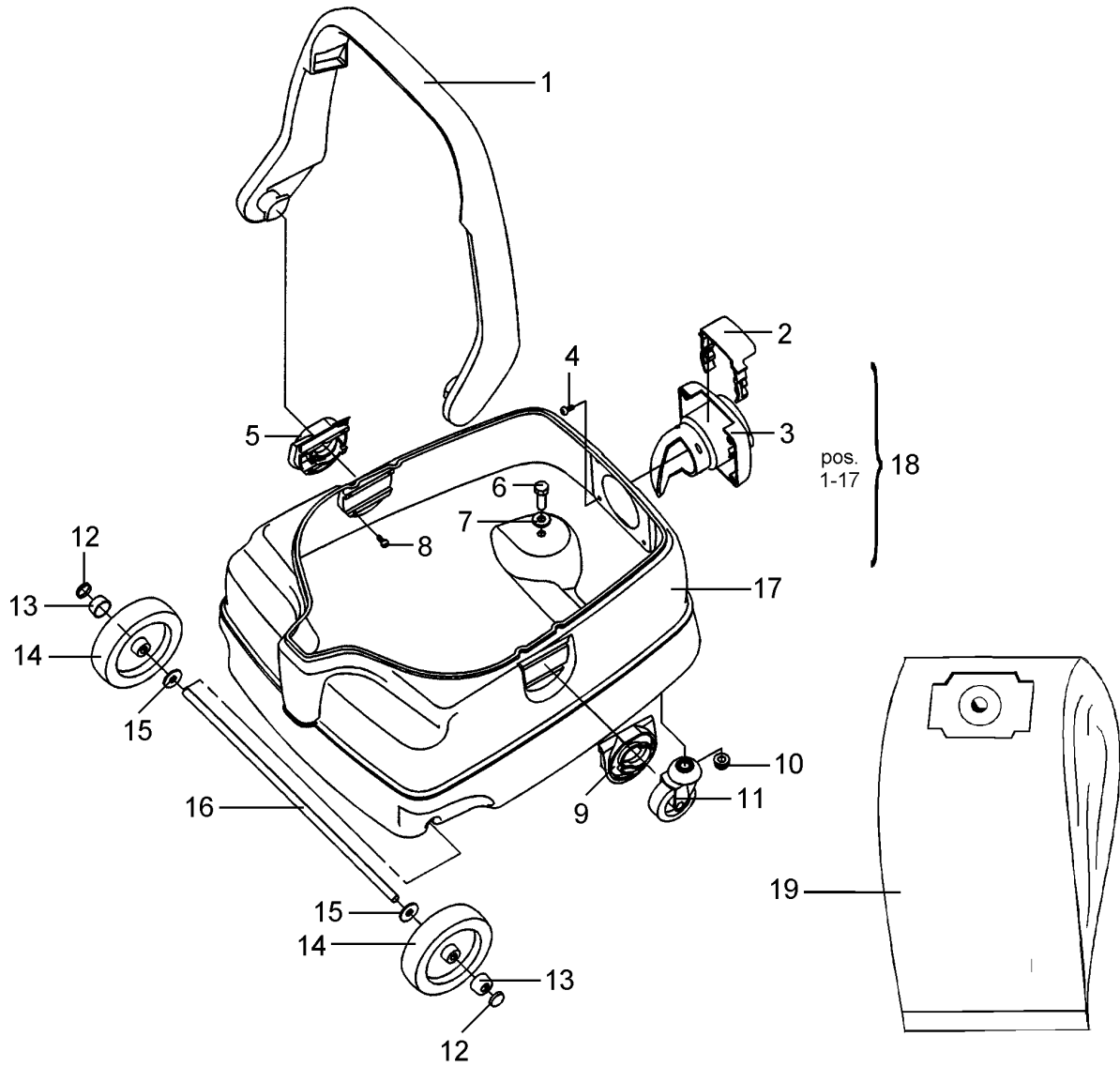

	<b>PART NUMBER</b>		
	<b>TANK, WD 215</b>		<b>9</b>

No.	Qty.	Part No.	Description
1	1	140 7206 000	Handle
2	1	140 7205 010	Trigger
3	1	140 7204 010	Inlet
4	4	140 9214 010	Screw
5	1	140 7207 010	Bracket, left
6	2	725 2370 400	Screw
7	2	140 7646 010	Washer
8	6	140 9214 000	Screw
9	1	140 7207 000	Bracket, right
10	2	140 7594 010	Nut
11	2	140 3916 000	Link wheel
12	2	140 5058 000	Lock washer
13	2	140 5057 000	Protection washer
14	2	140 5055 010	Wheel
15	2	734 1822 510	Washer
16	1	140 5059 010	Shaft
17	1	140 7201 000	Tank 15L
18		140 7200 000	Tank cpl. pos.1-17
19		140 7208 010	Dust bag 3 pcs
		140 7687 010	Dust bag 3 pcs, for larger float basket

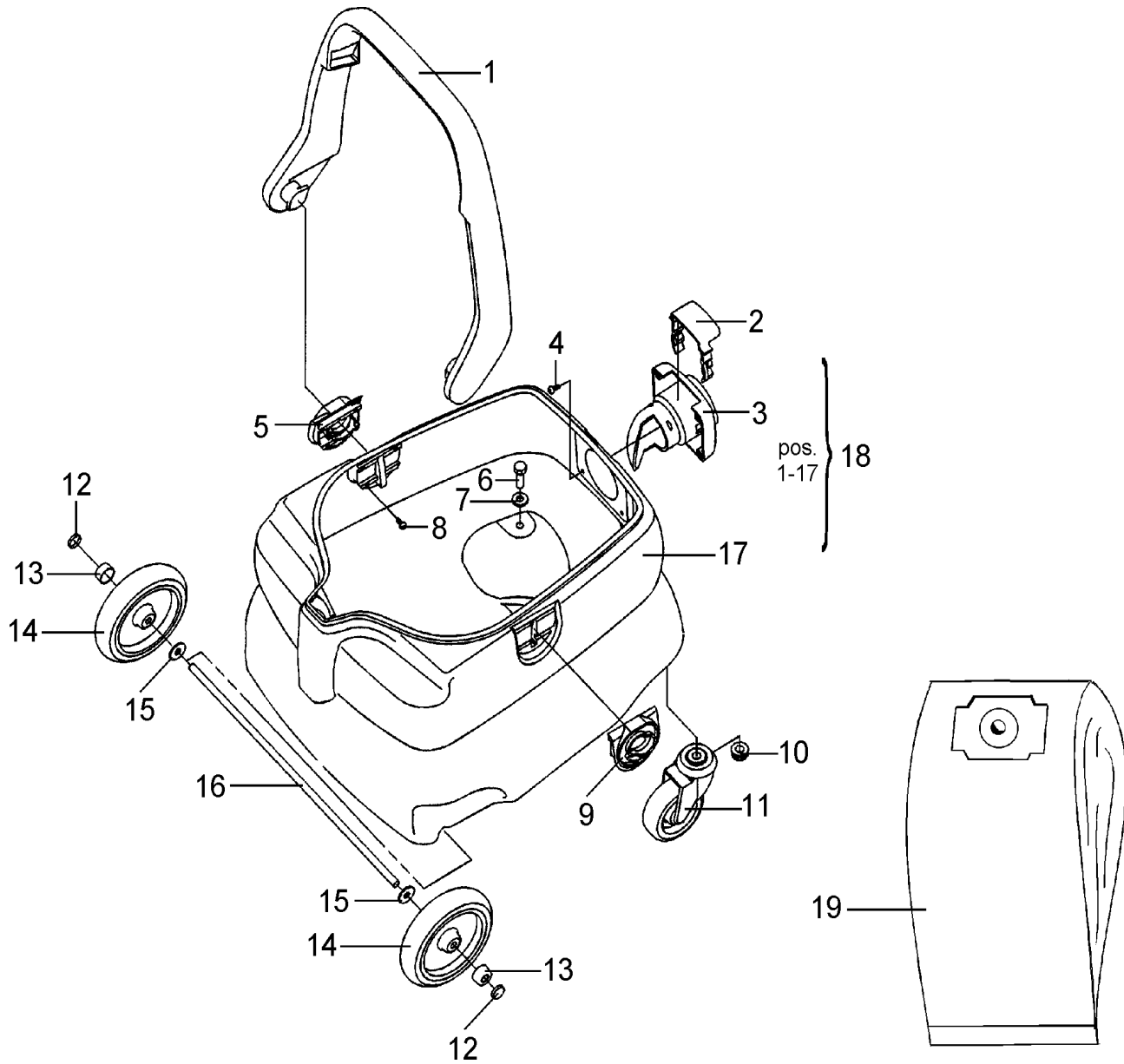

**PART NUMBER****TANK, WD 225 & KENT MICROVAC 6****11**

<b>No.</b>	<b>Qty.</b>	<b>Part No.</b>	<b>Description</b>
1	1	140 7206 000	Handle
2	1	140 7205 010	Trigger
3	1	140 7204 000	Inlet
4	4	140 9214 010	Screw
5	1	140 7207 010	Bracket, left
6	2	725 2453 400	Screw
7	2	140 7646 000	Washer
8	6	140 9214 000	Screw
9	1	140 7207 000	Bracket, right
10	2	140 7594 000	Nut
11	2	140 5476 020	Link wheel
12	2	140 5058 000	Lock washer
13	2	140 5057 000	Protection washer
14	2	140 7592 000	Wheel
15	2	734 1822 510	Washer
16	1	140 5059 020	Shaft
17	1	140 7203 000	Tank 25L
18		140 7202 000	Tank cpl. pos.1-17
19		140 7208 010	Dust bag 3 pc.
		140 7687 010	Dust bag 3 pcs, for larger float basket

LINE DRAWING

12

OLD HANDLE, TANK WD 245,260

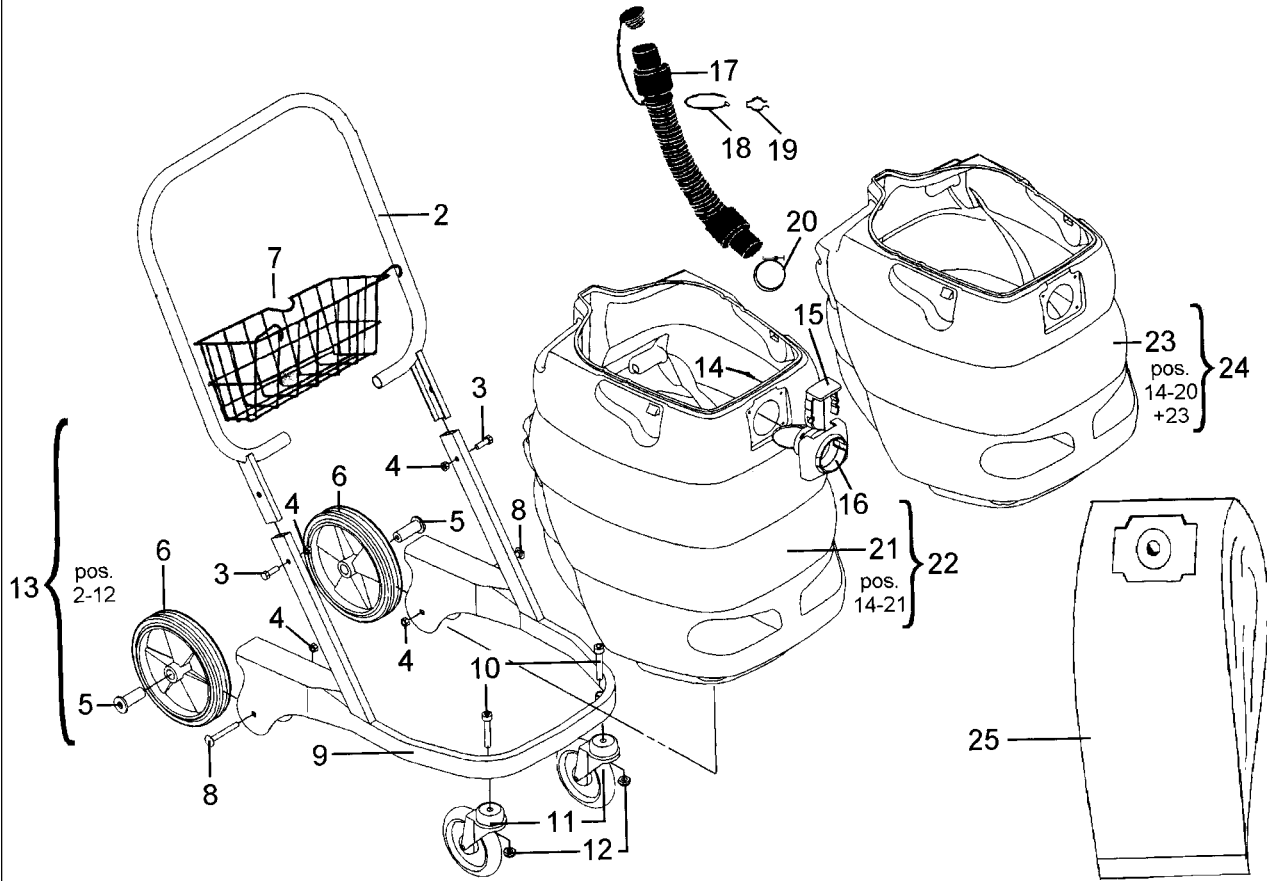

	<b>PART NUMBER</b>			
	<b>OLD HANDLE, TANK WD 245,260</b>			<b>13</b>

	No.	Qty.	Part No.	Description
(P)>>	2	1	140 7619 000	Handle
	3	2	725 2448 510	Screw
	4	4	732 2118 010	Locking nut
	5	2	140 7622 000	Spacer
	6	2	140 8156 000	Wheel
	7	1	140 4807 010	Basket
(P)>>	8	2	727 6464 010	Bolt
	9	1	140 7609 000	Bracket
	10	2	725 5502 010	Screw
	11	2	140 4664 000	Link wheel
	12	2	732 2120 010	Locking nut
	13		140 7610 000	Trolley cpl. pos.2-12
	14	4	140 9214 010	Screw
	15	1	140 7205 010	Trigger
	16	1	140 7204 010	Inlet
	17	1	140 7604 000	Drain hose
	18	1	465 0225 040	Plastic strip
	19	1	140 7623 000	Hose holder
	20	1	140 7636 000	Hose clamp
	21	1	140 7603 000	Tank 60L
	22		140 7602 000	Tank 60L cpl. pos.14-21
	23	1	140 7601 000	Tank 45L
	24		140 7600 000	Tank 45L cpl. pos.14-20+23
	25		140 7633 010	Dust bag 3 pcs. WD 245/60
			140 7695 000	Wet resistant dust bag 1 pcs. WD 245/260

**NOTE**

P means: Depleted when no longer on stock

**LINE DRAWING**

**14**

**NEW HANDLE TANK 245/260 MICROVAC 12,16, SPRITE 12,16**

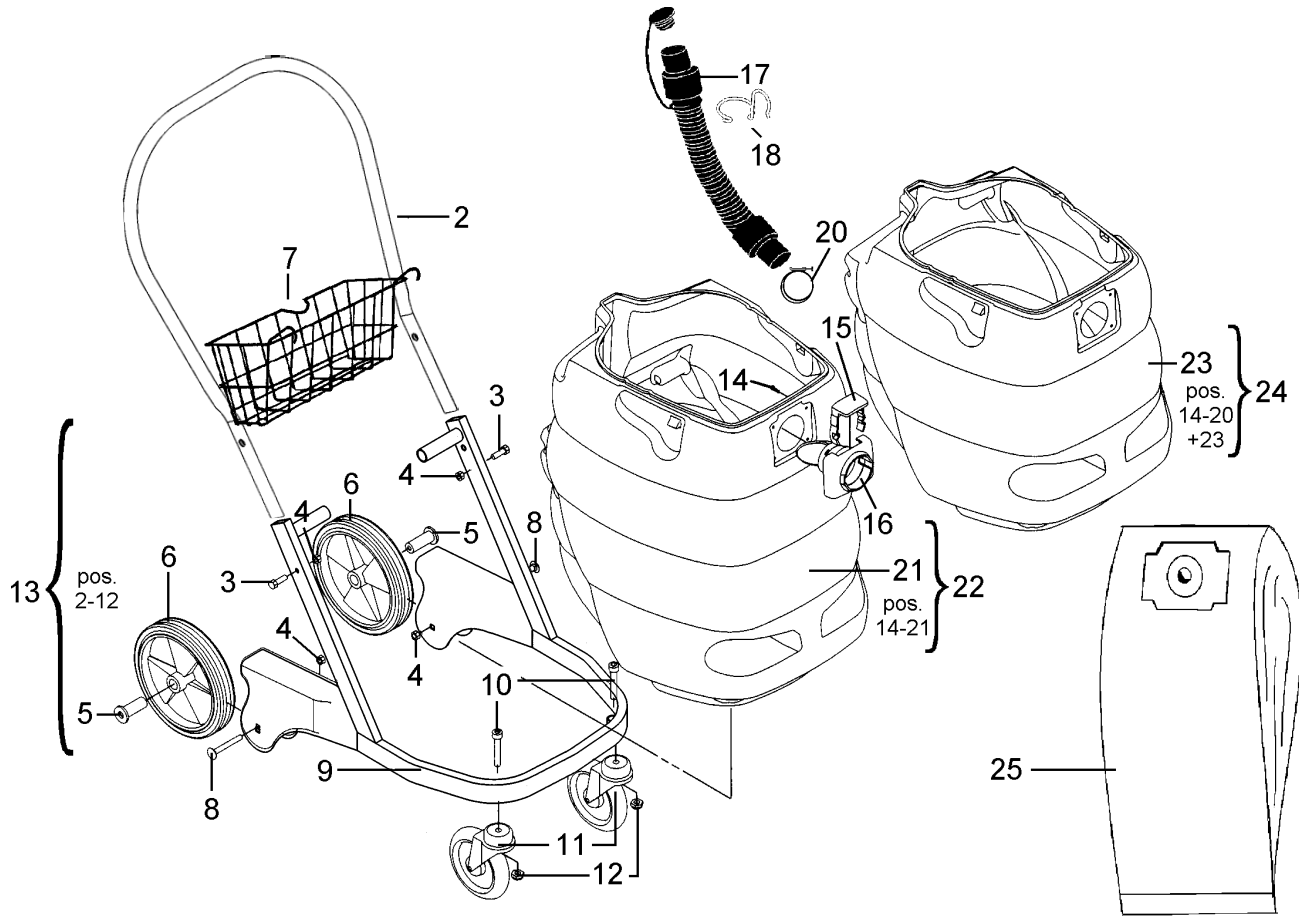

**PART NUMBER****NEW HANDLE, TANK 245/260, MICROVAC 12,16, SPRITE 12,16****15**

<b>No.</b>	<b>Qty.</b>	<b>Part No.</b>	<b>Description</b>
2	1	140 7648 000	Handle cpl.*
3	2	725 5447 010	Screw
4	4	732 2118 010	Locking nut
5	2	140 7622 000	Spacer
6	2	140 8156 000	Wheel
7	1	140 4807 010	Basket
8	2	727 6464 010	Bolt
9	1	140 7649 000	Carriage stand cpl.*
10	2	725 5503 010	Screw
11	2	140 4664 000	Link wheel
12	2	732 2120 010	Locking nut
13		140 7610 000	Trolley cpl *. pos.2-12
14	4	140 9214 010	Screw
15	1	140 7205 010	Trigger
16	1	140 7204 010	Inlet
17	1	140 7604 000	Drain hose
18	1	140 7618 000	Hook*
20	1	140 7636 000	Hose clamp
21	1	140 7603 000	Tank 60L
22		140 7602 000	Tank 60L cpl. pos.14-21
23	1	140 7601 000	Tank 45L
24		140 7600 000	Tank 45L cpl. pos.14-20+23
25		140 7633 010	Dust bag 3 pc. WD 245/60
		140 7695 000	Wet resistant dust bag 1 pcs. WD 245/260

**\***

The new handle 140 7648 000,  
and base part of the trolley 140 7649 000  
is delivered as standard from  
serial number 99350000.

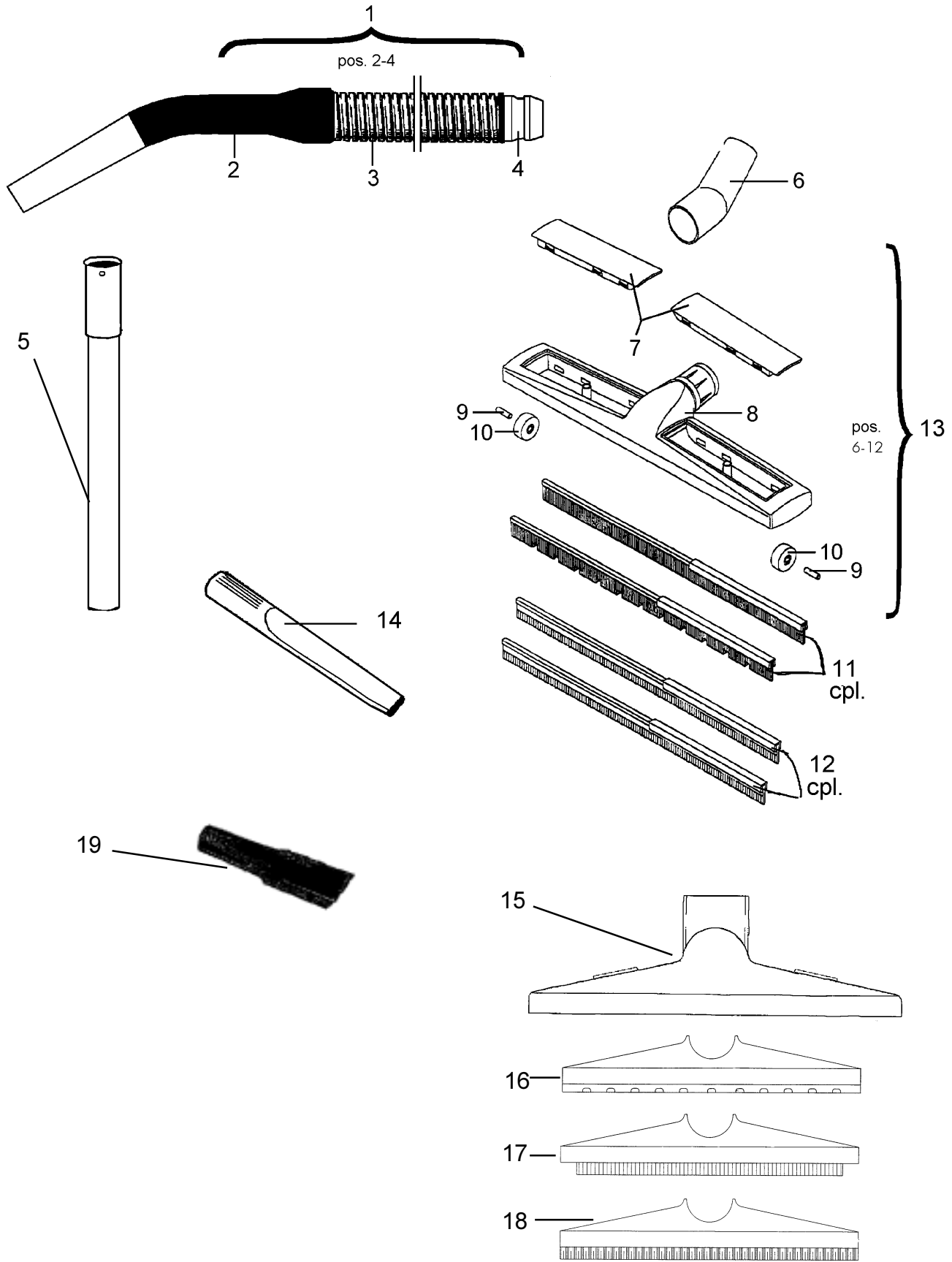

**PART NUMBER****HOSE, NOZZLE & TUBES****17**

<b>No.</b>	<b>Qty.</b>	<b>Part No.</b>	<b>Description</b>
1	1	140 4001 010	Hose, complete WD 200-series
	1	140 6588 030	Hose, 2,5 m complete with cuff, Sprite
2	1	140 5132 000	Hose handle complete
3	1	140 2148 060	Hose only 2,5m
4	1	140 3304 030	Inlet
5	2	011 6451 010	Extension tube
6	1	145 0772 000	Swivel elbow
7	2	145 0773 000	Cover
8	1	145 0774 000	Base unit
9	2	140 8744 000	Shaft
10	2	140 8743 000	Roll, wheel
11	1	145 1011 000	Brush strip, kit rear and back
12	1	145 1012 000	Rubber strip, kit rear and back
13		140 7629 000	Wet nozzle cpl. pos.6-12
		140 7629 010	Brush nozzle cpl.pos.6-11
14		140 3710 000	Crevice nozzle, aluminium
		010 8738 020	Crevice nozzle, plastic
15		140 8248 040	Universal nozzle, complete with inserts
16		140 8248 010	Carpet insert
17		140 8248 020	Rubber insert
18		140 8248 030	Brush insert
19		140 8258 000	Crevice nozzle, plastic

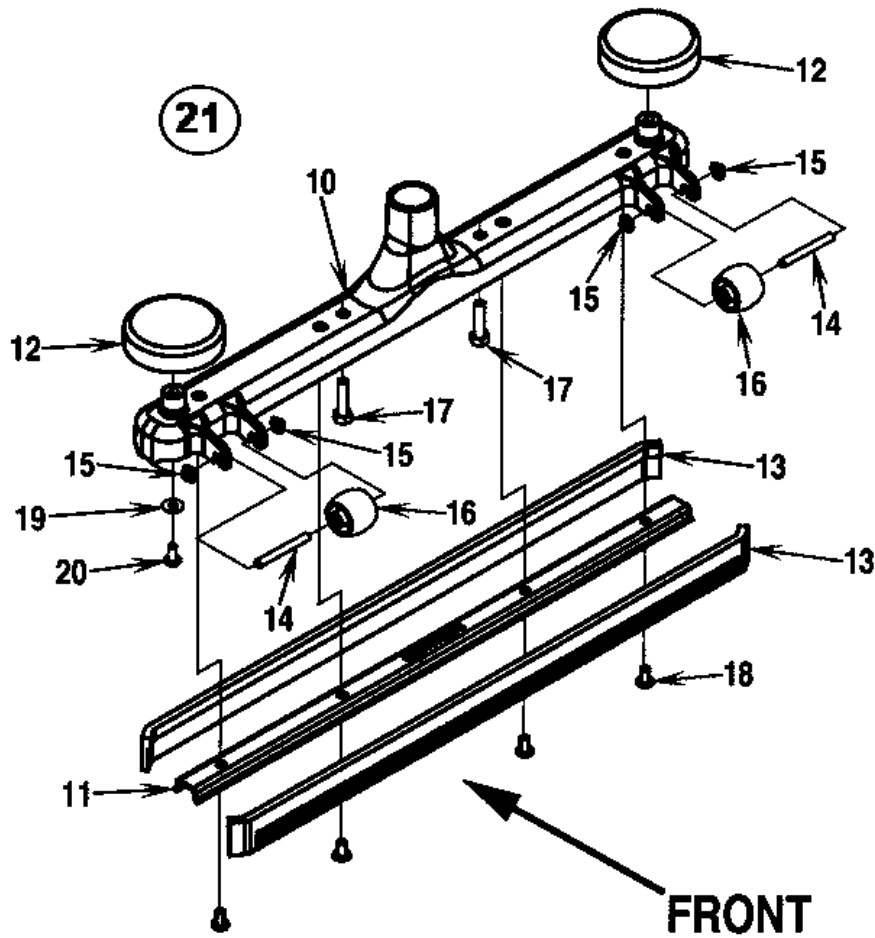
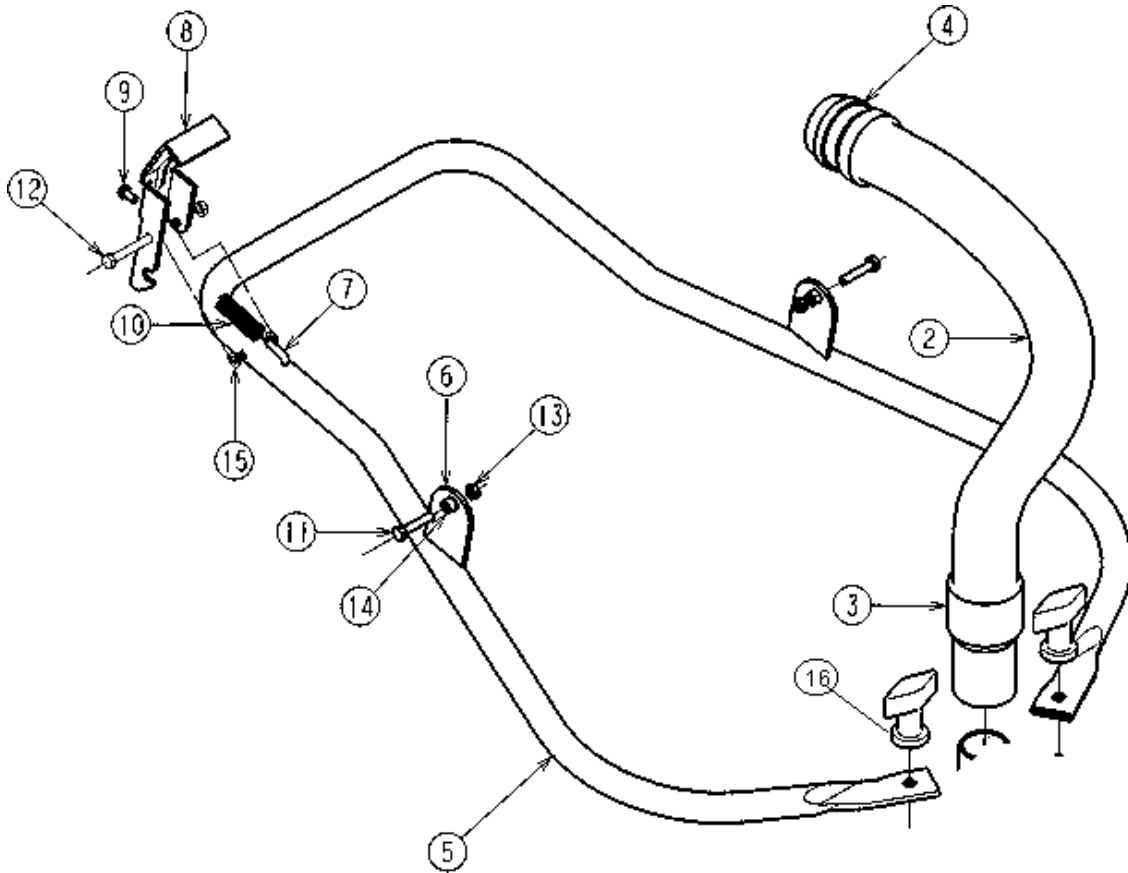

**PART NUMBER****FRONT NOZZLE - SQUEEGEE****19****BRACKET**

No.	Qty.	Part No.	Description
2	1	140 2148 070	Hose 1 1/2" 700 mm, 27,5 in for WD 260/Sprite 16
	1	140 2148 080	Hose 1 1/2" 500 mm, 19,6 in for WD 245/sprite 12
3	1	140 2291 000	Hose frame
4	1	140 3304 030	Hose sleeve
5	1	140 7857 000	Frame
6	2	140 7876 000	Bracket
7	1	140 7869 000	Spring mounting
8	1	140 7892 000	Pedal
9	1	140 7893 000	Rivet
10	1	140 7854 000	Spring 1.5x10x60 RF
11	2	725 2376 510	Screw 1.4 in M6x35 FZ
12	1	725 2379 510	Screw 1.7 in M6x45 FZ
13	3	140 7594 010	Collarnut M6
14	2	140 7894 000	Distance tube
15	2	734 1153 010	Washer 6.4x12 FZ
16	2	140 7947 000	Nut, thumb
		<b>140 5352 020</b>	<b>Hose cpl. 1 1/2" 700 mm/27,5 in for Sprite 16 /WD 260</b>
		<b>140 5352 030</b>	<b>Hose cpl. 1 1/2" 500 mm, 19,6 in for Sprite 12/WD 245</b>
		<b>140 7852 000</b>	<b>Frame cpl.</b>
		<b>140 7858 000</b>	<b>Pedal cpl.</b>

**FRONT NOZZLE**

No.	Qty.	Prod.nr.	Description
10	1	56209155	Housing 24" 60 cm
11	1	56209130	Retainer 24" 60 cm
12	2	56209157	Bumper, side roller
13	2	56105533	Blade 24" 60 cm
14	2	56209150	Axle
15	4	56009132	NutPush cap 1/4
16	2	56329554	Roller
17	2	56002884	Screw, Hex Hd SS 5/16" (8 mm) -18x1.25
18	4	56003119	Screw, Pan Phil SS 1/4"- (6 mm) 20x38
19	2	56009205	Washer Flt SS # 10
20	2	56009226	Screw, Pan Phil Type 25 SS 10-16x38
21		56209088	Squeegee cpl. item 10-20

**140 7850 010 Front nozzle kit complete**

Nozzle and Bracket complete delivered in a package.

**DOUBLE INSULATED**

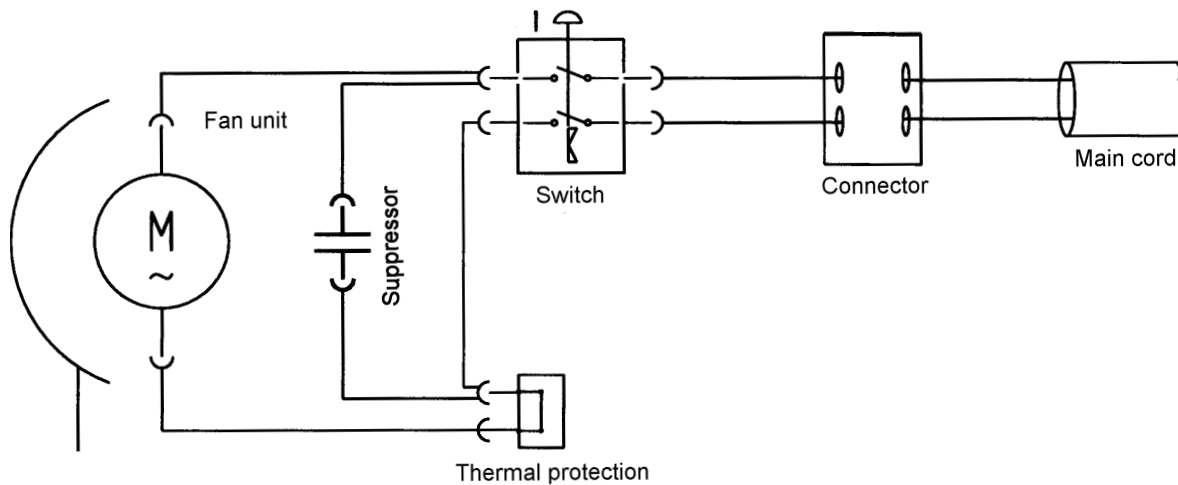

**US/CAN GROUNDED**

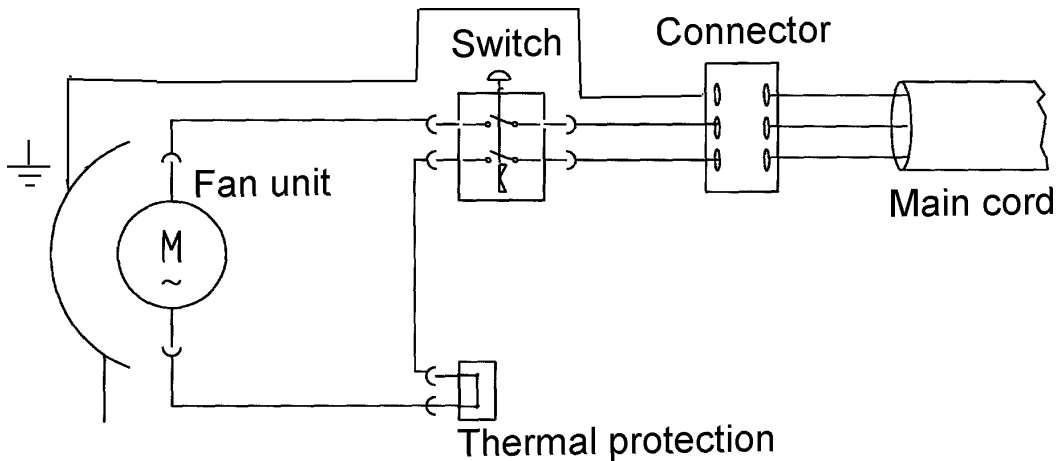

**US/CAN DOUBLE INSULATED**

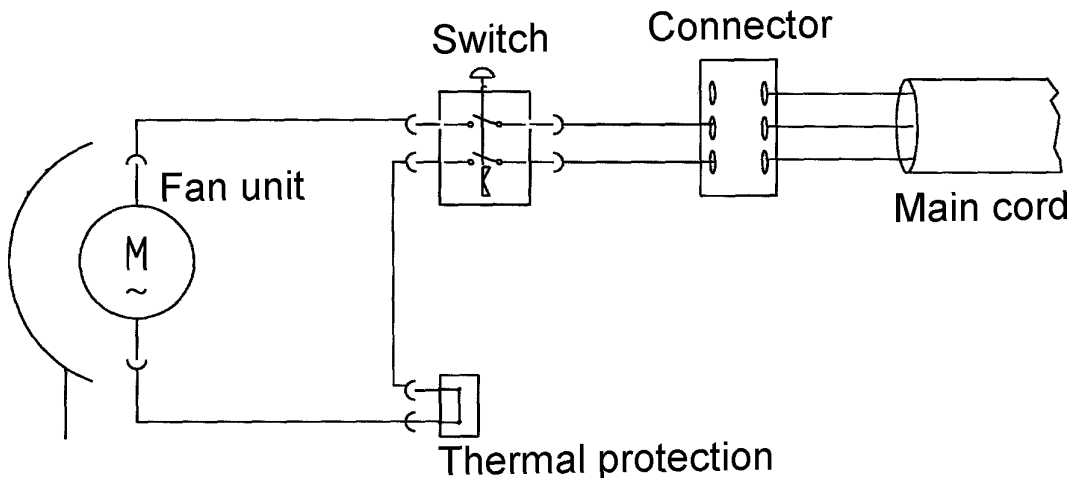

**DANMARK**

Nilfisk-Advance Nordic A/S  
 Myntevej 3, 8900 Randers  
 ☎ 86 42 84 33 – Fax 86 41 19 55

**NORGE**

Nilfisk-Advance AS  
 Enebakkvn, 119, 0680 Oslo, Postboks 196, Manglerud,  
 0612 Oslo  
 ☎ 22 08 63 50 – Fax 22 08 63 63  
 Distriktsrepresentanter over hele landet

**SVERIGE**

Nilfisk-Advance AB  
 Sjöbjörnsvägen 5, 117 67 Stockholm  
 ☎ 085 55 944 00 – Fax 085 55 944 30

**FINLAND/ SUOMI**

Oy Tecalemit AB  
 Hankasuontie 13, 00390 Helsinki  
 ☎ (89) 547 701 – Fax (89) 547 1779

**AUSTRALIA**

Nilfisk-Advance Pty. Ltd.  
 ACN 003 762 623  
 Head office: 17 Leeds Street, Rhodes, N. S. W. 2138  
 ☎ (02) 9736 1244 – Fax (02) 9736 3910  
 Customer Responce Centre:  
 ☎ 1 800 011 013

**BELGIQUE / BELGIË/ LUXEMBOURG**

Nilfisk-Advance s.a./n.v.  
 Doornveld/ Sphere Business Park  
 Industrie Asse 3, nr 11 – bus 41  
 1731 Zellik-Asse  
 ☎ (02) 467.60.50 Fax (02) 463.44.16

**CANADA**

Nilfisk-Advance Ltd.  
 396 Watline Avenue  
 Mississauga, Ontario L4Z 1X  
 ☎ (905) 712-3260 – Fax (905) 712-3255

**DEUTSCHLAND**

Nilfisk-Advance AG  
 Siemensstraße 25-27  
 25462 Rellingen  
 ☎ (041 01) 3990 – Fax (04101) 399191  
 Zentraler Kundenservice  
 ☎ für die Industrie: 0180 535 67 97  
 ☎ Institutionen und Gebäudereiniger: 0180 500 11 70

**FRANCE**

Nilfisk-Advance S.A.  
 BP 246  
 91944 Courtaboeuf Cedex  
 ☎ (01) 69.59.87.00 Télécopie (01) 69.59.87.01

**HONG KONG**

Nilfisk-Advance Ltd.  
 2001, 20/F HK Worsted Mills  
 Industrial Building  
 31-39 Wo Tong Tsui Street  
 Kwai Chung, N.T.  
 ☎ 2427 59 51 – Fax 2487 5828

**IRELAND**

Nilfisk-Advance Ltd.  
 28 Sandyford Office Park  
 Dublin 18  
 ☎ +353 1 2943838 – Fax +353 1 2943845

**JAPAN**

Nilfisk-Advance Inc.  
 3-4-9 Chigasaki Minami  
 Tsuzuki-Ku Yokohama 224  
 ☎ 045-942-7741 – Fax 045-942-6545

**MALAYSIA**

Nilfisk-Advance Sdn Bhd  
 Lot 2, 1<sup>st</sup>. Floor  
 Lorong 19/1A  
 46300 Petaling Jaya  
 Selangor Darul Ehsan  
 ☎ 03-7568188/03-7568189/03-7568388 – Fax 03-7566828

**NEDERLAND**

Nilfisk-Advance B.V.  
 Flevolaan 7, Postbus 341  
 1380 AH Weesp  
 ☎ 0294-462121 – Fax 0294-430053

**NEW ZEALAND**

Nilfisk-Advance Limited  
 477 Great South Road, Penrose  
 Auckland  
 ☎ (09) 525 0092 – Fax (09) 525 6440

**SCHWEIZ / SUISSE**

Nilfisk-Advance AG  
 Ringstrasse 19, 9533 Kirchberg/Wil  
 ☎ 719 23 52 83 – Fax 719 23 84 44

**SINGAPORE**

Nilisk-Advance Pte. Ltd.  
 10, Woodlands Loop  
 Singapore 738388  
 ☎ (65) 759 9100 – Fax (65) 759 9133

**TAIWAN**

Nilfisk-Advance Ltd.  
 1 F, No.23, Lane 132, Sec. 2  
 Ta An Road, Taipei  
 ☎ 700 22 68 – Fax 784 08 43

**UNITED KINGDOM**

Nilfisk-Advance Limited  
 Newmarket Road  
 Bury St. Edmunds  
 Suffolk IP 33 3SR  
 ☎ (01284) 763163 – Fax (01284) 750562

**USA**

Nilfisk-Advance Inc.  
 14600 21<sup>st</sup> Avenue North  
 Plymouth, MN 55447-3408  
 ☎ +1 763 745 3500 – Fax 1 763 745 3895

Nilfisk-Advance of America, Inc.

300 Technology Drive  
 Malvern, PA 19355  
 ☎ (610) 647 647-6427

**ÖSTERREICH**

Nilfisk-Advance GmbH  
 Vorarlberg Allee 46  
 1230 Wien  
 ☎ 1 616 58 30 – Fax 1 616 58 30 40

**ESPAÑA**

Nilfisk-Advance, S.A.  
 Torre D'Ara  
 Passeig del Rengle, 5 Pl.9-10  
 E-08302 – Mataró (Barcelona)  
 ☎ Tel. 93 741 24 00 – Fax: 93 757 80 20  
 Central atención al cliente: 902 200 201  
[nilfisk@nilfisk-advance.es](mailto:nilfisk@nilfisk-advance.es) – [www.nilfisk-advance.com](http://www.nilfisk-advance.com)  
 Distribuidores y Servicio Técnico en toda España y Andorra

**ITALIA**

Nilfisk-Advance Italia Spa  
 Località Novella Terza  
 26862 Guardamiglio (LO)  
 Italy  
 ☎ +39 0377 414021 – Fax +39 0377 414097  
[www.nilfisk-advance.com](http://www.nilfisk-advance.com)

**PORTUGAL**

Nilfisk-Advance Lda.  
 Rua Cândido de Figueiredo, 91-i, 1500-133 LISBOA  
 ☎ 01/7784142 – Fax 01/7785613  
 Porto 02/526766 – Fax 02/520739  
 Açores 096/628092/3 – Fax 096/628129  
 Madeira 091/228965 – Fax 091/228796

**GREECE**

Embiom S.A.  
 Λεωφ. Βουλιαγμένης 60  
 Αργυρούπολη  
 164 52 Αθήνα  
 ☎ 9950613 - Fax 9951680

