

# Castex®

## BR-2000

Battery Burnisher

Model No.:  
607418

Operator and Parts Manual

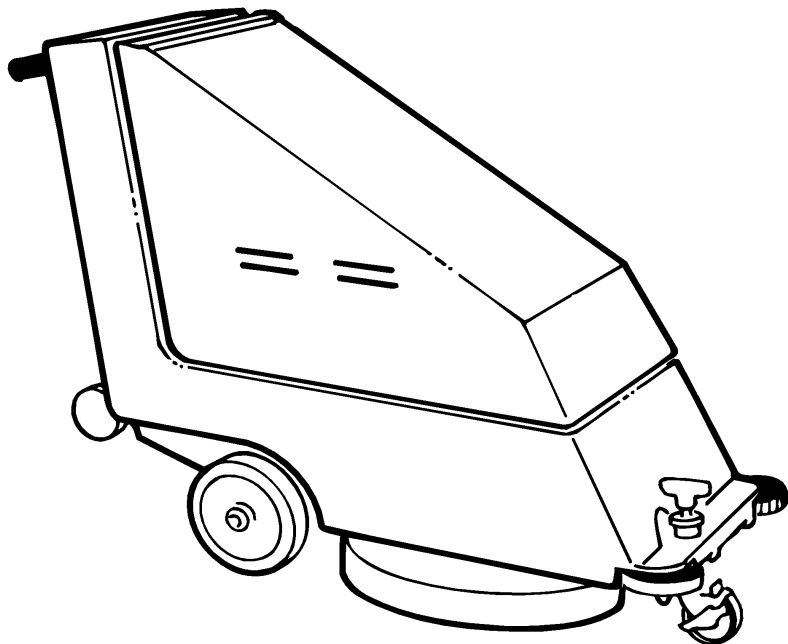

**CASTEX INCORPORATED**  
12875 RANSOM STREET  
HOLLAND MI 49424 U.S.A.

A TENNANT COMPANY

1-800-522-7839  
616-786-2330  
FAX: 1-800-678-4240  
CUSTOMER SERVICE: 1-800-964-9644

608265  
Rev. 00 (07-99)

# OPERATION

---

This manual is furnished with each new model. It provides necessary operation, machine maintenance instructions and an illustrated parts list.

**Read this manual completely and understand the machine before operating or servicing.**

A complete illustrated Parts Lists is supplied with this manual, use this list to order parts. Before ordering parts or supplies, be sure to have your machine model number and serial number handy. Parts and supplies may be ordered by phone or mail from any authorized parts and service center, distributor or from any of the manufacturer subsidiaries.

This machine will provide excellent service. However, the best results will be obtained at minimum costs if:

- The machine is operated with reasonable care.
- The machine is maintained regularly - per the machine care instructions provided.
- The machine is maintained with manufacturer supplied or equivalent parts.

---

## MACHINE DATA

---

Please fill out at time of installation for future reference.

Model No.- \_\_\_\_\_

Install. Date - \_\_\_\_\_

Serial No.- \_\_\_\_\_

©1999 Tennant Company

Printed in U.S.A.

Castex is a registered United States trademark of Tennant Company.

---

## TABLE OF CONTENTS

---

SAFETY PRECAUTIONS .....	3	MAINTENANCE .....	9
MACHINE COMPONENTS .....	4	DAILY MAINTENANCE .....	9
MACHINE INSTALLATION .....	5	WEEKLY MAINTENANCE .....	9
MACHINE UNCRATING .....	5	MONTHLY MAINTENANCE .....	9
BATTERY INSTALLATION .....	5	EVERY 250 HOURS OF OPERATION .....	9
MACHINE SETUP .....	6	BATTERY MAINTENANCE .....	10
PRE-OPERATION CHECKS .....	6	TRANSPORTING MACHINE .....	10
INSTALLING PAD .....	6	STORING MACHINE .....	10
MACHINE OPERATION .....	7	RECOMMENDED STOCK ITEMS .....	10
WHILE OPERATING MACHINE .....	8	TROUBLE SHOOTING .....	11
PAD MOTOR CIRCUIT BREAKER .....	8	SPECIFICATIONS .....	11
BATTERY CHARGING .....	8	PARTS LIST .....	12
		ELECTRICAL DIAGRAM .....	16

---

## SAFETY PRECAUTIONS

---

This machine is suited to burnish smooth floors in an indoor environment and is not constructed for any other use. Use only recommended pads and cleaning solutions.

All operators must read, understand and practice the following safety precautions:

The following safety alert symbols are used throughout this manual as indicated in their description.

 **WARNING:** To warn of hazards or unsafe practices which could result in severe personal injury or death.

**FOR SAFETY:** To identify actions which must be followed for safe operation of equipment.

The following information signals potentially dangerous conditions to the operator or equipment:

### FOR SAFETY:

1. **Do not operate machine:**
  - Unless trained and authorized.
  - Unless operation manual is read and understood.
  - In flammable or explosive areas unless designed for use in those areas.
2. **Before starting machine:**
  - Make sure all safety devices are in place and operate properly.
3. **When using machine:**
  - Go slow on inclines and slippery surfaces.
  - Use care when reversing machine.
  - Always follow safety and traffic rules.
  - Report machine damage or faulty operation immediately.
4. **Before leaving or servicing machine:**
  - Stop on level surface.
  - Turn off machine.

### 5. When servicing machine:

- Avoid moving parts. Do not wear loose jackets, shirts, or sleeves.
- Block machine tires before jacking machine up.
- Use hoist or jack of adequate capacity to lift machine.
- Disconnect battery connections before working on machine.
- Wear protective gloves when handling batteries or battery cables.
- Avoid contact with battery acid.
- Use manufacturer supplied or approved replacement parts.

 **WARNING:** Batteries emit hydrogen gas. Explosion or fire can result. Keep sparks and open flame away. Keep battery compartment open when charging.

 **WARNING:** Flammable materials or reactive metals can cause explosion or fire. Do not pick up.

# OPERATION

---

## MACHINE COMPONENTS

---



1. Control Console
2. Control Grips
3. Machine ON/OFF Switch
4. Power ON Indicator Light
5. Battery Level Meter
6. Pad Pressure Meter
7. Circuit Breaker Button



8. Small Rear Wheels  
– for tilting back machine to install pad.
9. Pad Pressure Adjustment Knob
10. Wall Rollers
11. Front Caster
12. Pad Guard
13. Battery Hood
14. Battery Hood Latch
15. Pad Driver
16. Main Wheels

---

## MACHINE INSTALLATION

---

### MACHINE UNCRATING

Carefully check carton for signs of damage. Report damages at once to carrier. Batteries and battery charger are packaged separately.

Battery installation must be accomplished **after** removing machine from crate.

To uncrate your machine remove straps and carefully lift or create a ramp using crate boards to remove machine from pallet.

**ATTENTION: Do not roll machine off pallet, damage may occur.**

---

### BATTERY INSTALLATION

**⚠ WARNING: Batteries emit hydrogen gases. explosion or fire can result. Keep sparks and open flame away. Keep covers open when charging.**

**FOR SAFETY: When servicing machine, wear protective gloves when handling batteries or battery cables. Avoid contact with battery acid.**

#### Recommended Battery Specifications:

Two 12 volt deep cycle 215 amp hour batteries. Part Number #600394. Maximum battery dimensions are 7in.W (178 mm) x 15.5in.L (394 mm) x 14.25in.H (362mm).

**FOR SAFETY: Before leaving or servicing machine, stop on level surface and turn off machine.**

1. Be certain ON/OFF switch is turned off.
2. Remove front hood to access battery compartment. Remove loose battery cable (Fig.1).



Fig. 1.

3. Carefully install batteries into compartment and arrange battery posts as shown (Fig. 2).



Fig. 2.

**ATTENTION: Do not drop batteries into compartment! Battery and machine housing damage may result. This damage is not covered by warranty.**

4. Connect cables to battery posts in numerical order as labeled. RED TO POSITIVE (+) & BLACK TO NEGATIVE (-) (Fig. 2).
5. Cover cable connections with rubber boots. Double check cable connections before closing up battery compartment.
6. Replace hood and secure with latches.

# OPERATION

---

---

## MACHINE SETUP

---

---

### PRE-OPERATION CHECKS

1. Sweep the floor to remove particles and other debris.
2. Check battery meter charge level to ensure batteries are fully charged (See BATTERY CHARGING).
3. Check that a pad is installed.
4. Before burnishing make sure floor is dry.

---

### INSTALLING PAD

**FOR SAFETY: Before leaving or servicing machine, stop on level surface and turn off machine.**

1. Tilt machine back until it rests on small rear wheels (*Fig. 3*).



**Fig. 3.**

**ATTENTION: Do not leave machine tilted back for an extended time. Battery acid may run out the top of batteries. Battery acid can cause severe burns on contact with skin.**

2. Remove plastic center pad lock by turning lock counter-clockwise (*Fig. 4*).
3. Select a pad that is recommended for 2000 RPM burnishing. The pad should be a maximum of 25.4 mm (1 inch) thick, 508 mm (20 inch) in diameter with a standard 89 mm (3.5 inch) center hole. Machine is not designed for spray buffing.

**NOTE: Consult your authorized distributor to assist you in choosing the correct pad for your specific burnishing need.**

4. Position pad centered on pad driver and replace centerlock securely (*Fig. 4*).



**Fig. 4.**

**ATTENTION: Make sure centerlock does not cross thread or floor damage could occur. Do not over tighten.**

**ATTENTION: Do not operate machine without a pad and the pad centerlock in place.**

5. Return machine to operating position immediately.

**MACHINE OPERATION**

**FOR SAFETY: Do not operate machine unless operator manual is read and understood.**

1. Adjust pad to correct pad pressure: With pad installed and caster wheel swung towards pad driver, rotate pad pressure adjustment knob clockwise until pad is not touching floor, (check by manually spinning pad; it should turn freely) (Fig. 5).



Fig. 5.

2. While manually spinning the pad, increase pad pressure by rotating knob counter clockwise, until pad contacts the floor enough to stop the pad. Then turn knob counterclockwise one more rotation. This setting will be very close to the operating setting. Continue through instructions to achieve exact setting.
3. Activate ON/OFF switch.
4. Twist control grips forward to activate the pad (Fig. 6).

**NOTE:** If there is excess vibration realign pad.

**FOR SAFETY: When using machine, go slow on inclines and slippery surfaces.**



Fig. 6.

**ATTENTION: To prevent floor damage, machine must be kept moving.**

5. Lock pad pressure adjustment knob to correct pad pressure setting: Turn knob counter clockwise until pad pressure meter reads in the green zone. Then lock adjustment knob by turning knurled nut clockwise (Fig. 7).



Fig. 7.

6. If machine circuit breaker trips, check pad pressure and/or replace soiled pad. Reset circuit breaker button after allowing motor to cool (Fig. 8). See PAD MOTOR CIRCUIT BREAKER

# OPERATION

---



Fig. 8.

7. Begin burnishing by pushing machine forward.
8. Turn ON/OFF switch off when not in use or when charging.

---

## WHILE OPERATING MACHINE

Periodically check battery meter's discharge level. When needle drops to the red zone recharge batteries (See BATTERY CHARGING).

**ATTENTION: Do not continue to run machine when battery meter needle is in the red zone, battery damage will result.**

**FOR SAFETY: Before leaving machine, stop on level surface and turn off machine.**

---

## PAD MOTOR CIRCUIT BREAKER

Machine is equipped with a circuit breaker to protect pad motor from damage. If the pad motor circuit breaker trips, it can not be reset immediately. Determine reason why breaker tripped, allow motor to cool and then reset. Circuit breaker will trip due to excessive overload on pad. Clean or change pad if breaker should trip. Pad motor circuit breaker button is located at left side of control console.

---

## BATTERY CHARGING

---

**ATTENTION: The following charging instructions are intended for supplied 24V chargers only. Otherwise use a charger with the following specifications to prevent battery damage.**

### CHARGER SPECIFICATIONS:

- OUTPUT VOLTAGE - 24 VOLTS
- OUTPUT CURRENT - 25 AMPS
- AUTOMATIC SHUTOFF CIRCUIT
- FOR DEEP CYCLE BATTERY CHARGING

**NOTE:** For optimum machine operation, keep batteries charged at all times. Never let batteries set in a discharge condition.

**ATTENTION: Do not continue to run machine when battery meter needle is in the red zone, battery damage will result.**

**⚠ WARNING: Batteries emit hydrogen gas. Explosion or fire can result. Keep sparks and open flame away. Keep covers open when charging.**

**FOR SAFETY: When servicing machine, wear protective gloves when handling batteries or battery cables. Avoid contact with battery acid.**

1. Transport machine to a well ventilated area when charging.
2. Turn ON/OFF switch off.
3. Remove hood to access battery compartment (Fig. 9).



Fig. 9.

4. Check water lever "A" in each battery cell. Do not charge batteries unless water is slightly covering battery plates "B". If needed, add just enough distilled water to slightly cover plates. DO NOT overfill. Batteries can overflow during charging due to expansion. Replace cell caps before charging (Fig. 10).

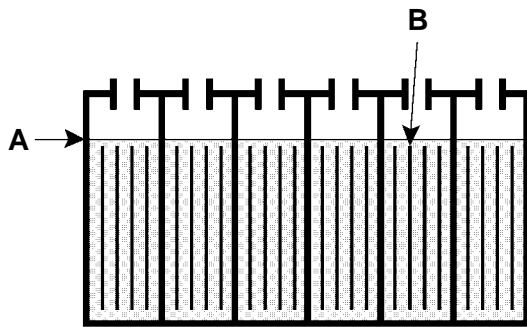

Fig. 10.

5. Plug charger into charger receptacle located near battery cable connections (Fig. 11).



Fig. 11.

**NOTE:** Once the charger is connected to the machine, machine becomes inoperable.

6. Plug charger into grounded wall outlet after connecting charger to machine (Fig. 12).

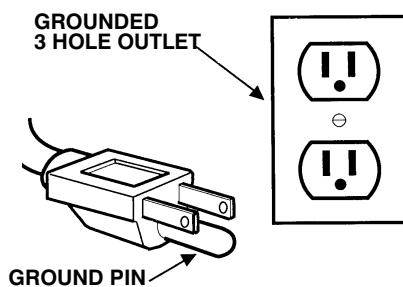

Fig. 12.

7. Charger will automatically begin charging and shut off when fully charged.
8. After charger has turned off, unplug charger from wall outlet first then disconnect charger from the machine.

9. Recheck battery fluid level **after** charging. If needed, add distilled water to bring level of fluid to bottom of sight tubes. Be certain to replace cell caps securely and to wipe off the top of batteries with a clean cloth.

## MAINTENANCE

To keep machine in good working condition, simply follow machines daily, weekly and monthly maintenance procedures.

**FOR SAFETY: Before leaving or servicing machine, stop on level surface and turn off machine.**

**FOR SAFETY: Before servicing machine, disconnect battery connections.**

### DAILY MAINTENANCE

1. Remove and clean pad. Never use soiled pads when burnishing. Replace pad when it becomes loaded with residue.
2. Clean machine housing with a nonabrasive, non-solvent cleaner.
3. Recharge batteries if needed.

### WEEKLY MAINTENANCE

1. Check water level in battery cells (See BATTERY MAINTENANCE).
2. Clean battery tops of corrosion.
3. Check for loose or corroded battery cables.

### MONTHLY MAINTENANCE

1. Lubricate axle and caster grease fittings with a water resistant grease.
2. Check machine for loose nuts and bolts.

### EVERY 250 HOURS OF OPERATION

Check pad motor for carbon brush wear, replace brushes if necessary.

# OPERATION

## BATTERY MAINTENANCE

**⚠ WARNING:** Batteries emit hydrogen gas. Explosion or fire can result. Keep sparks and open flame away. Keep battery compartment open when charging.

**FOR SAFETY:** When servicing machine, wear protective gloves when handling batteries or battery cables. Avoid contact with battery acid.

1. Always follow proper charging instructions (See CHARGING BATTERIES).
2. Each week AFTER charging, check water level in each battery cell of all batteries. Water level (A) should reach bottom of sight tubes (B). If needed, add just enough distilled water to reach bottom of sight tubes. DO NOT overfill (Fig. 13).

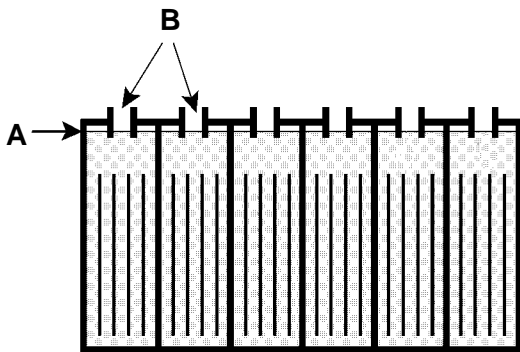

Fig. 13.

3. Keep battery tops and terminals clean and dry.
  - a. Mix a strong solution of baking soda and water.
  - b. Brush solution sparingly over battery tops, terminal and cable connectors.

**NOTE:** Do not allow baking soda solution to enter battery cells.

- c. Use wire brush to clean terminal post and cable connections.
  - d. After cleaning, apply a coating of clear battery post protectant to terminals and cable connections.
4. Check for loose or worn cables. Replace if worn.

## TRANSPORTING MACHINE

When transporting machine by use of a trailer or truck, be certain to follow tie-down procedures below:

1. Raise pad with pad pressure adjustment knob.
2. Tilt machine back on small wheels and load machine using a recommended loading ramp.

**ATTENTION:** Do not transport machine tilted back on small rear wheels. Battery acid may run out the top of batteries. Battery acid can cause severe burns on contact with skin.

3. Position front of machine up against front of trailer or truck.
4. Place a block behind the rear wheels and the front casters.
5. Place tie-down straps over top of machine and secure straps to floor. It may be necessary to install some tie-down brackets to the floor of your trailer or truck.

## STORING MACHINE

Remove pad and store machine in a dry area in the upright position.

**ATTENTION:** Do not store machine tilted back on small rear wheels. Battery acid may run out the top of batteries. Battery acid can cause severe burns on contact with skin.

## RECOMMENDED STOCK ITEMS

Refer to Parts List section for recommended stock items. Stock Items are clearly identified with a bullet preceding the parts description. See example below:

Ref.	Part No.	Description	Qty.
1	701183	ASM_STANDPIPE	1
2	708513	•FLCHG, SHUTOFF	1
3	228187	•NIPPLE	1
4	701714	•GASKET	1
5	218249	NUT, FLANGED	1

**TROUBLE SHOOTING**

<b>PROBLEM</b>	<b>CAUSE</b>	<b>SOLUTION</b>
No power, nothing runs.	Faulty ON/OFF switch	Contact Service Center.
	Batteries need charging.	See Battery Charging
	Battery(s) faulty.	Replace battery(s)
	Loose battery cable.	Tighten loose cables.
	Batteries are not connected correctly.	See Battery Installation.
Pad motor does not run.	Faulty roll switch.	Contact Service Center.
	Machine circuit breaker has tripped.	Clean or replace pad and reset breaker button.
	Faulty contactor.	Contact Service Center.
	Faulty wiring.	Contact Service Center.
	Faulty pad drive motor.	Contact Service Center.
	Carbon brushes worn.	Contact Service Center.
Short run time.	Batteries not fully charged.	Charge batteries.
	Bad cell in one or more batteries.	Replace battery.
	Batteries need maintenance.	See Battery Maintenance.
	Faulty charger.	Replace charger.

**SPECIFICATIONS**

<b>MODEL</b>	<b>BR-2000</b>
LENGTH	1320 mm (52 in)
WIDTH	610 mm (24 in)
HEIGHT	940 mm (37 in)
WEIGHT WITH BATTERIES	169 Kg (364 lbs)
PAD DIAMETER	508 mm (20 in)
BRUSH MOTOR	2hp, 2100 rpm brush speed, 24v, 90A, 1500w
BATTERIES	2-215amp/hour, 12v deep cycle
RUN TIME on full charge	3 hours
DECIBEL RATING AT OPERATOR'S EAR, INDOORS ON TILE	<70dB(A)

CHASSIS ASSEMBLY

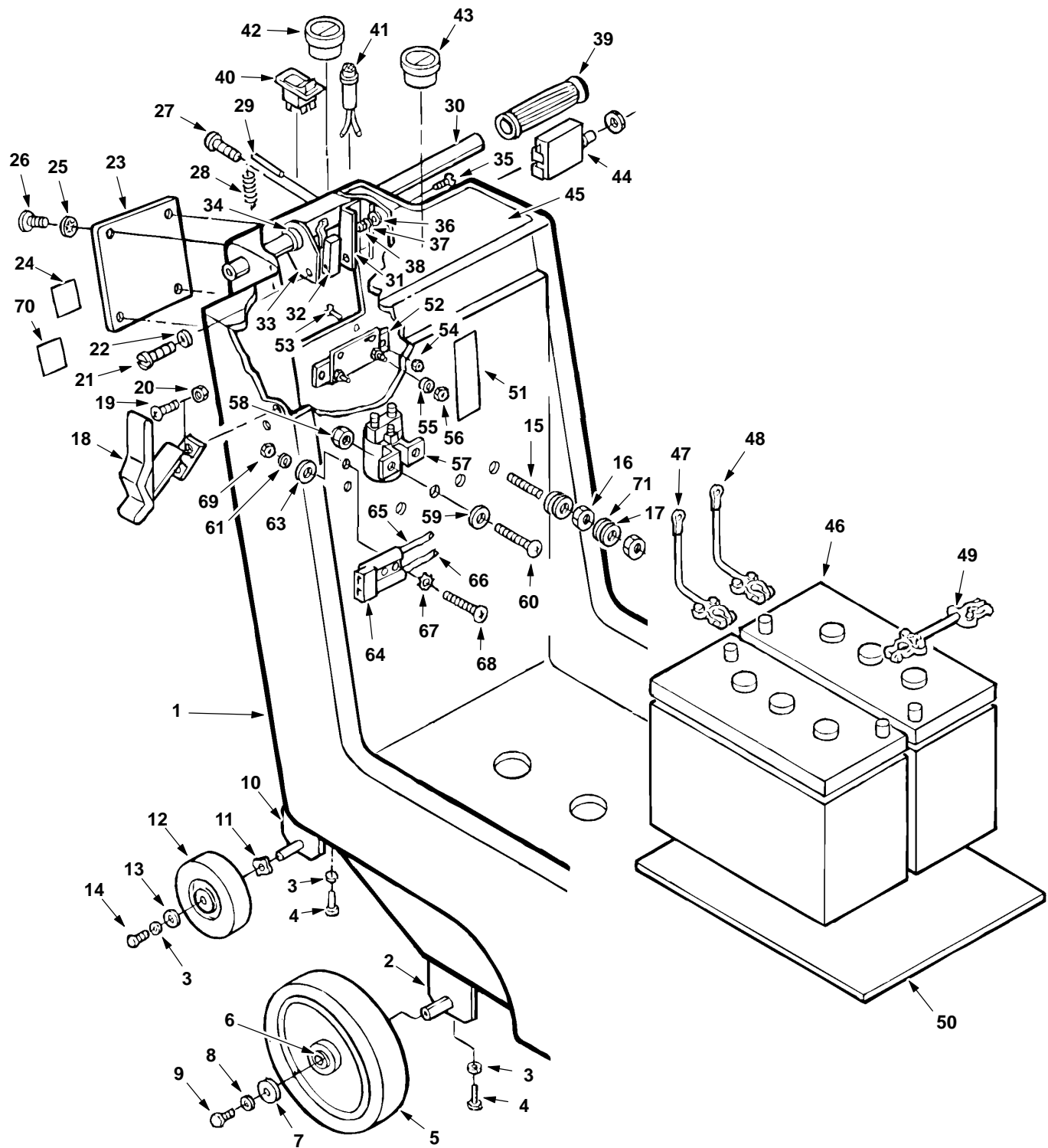

## CHASSIS ASSEMBLY

REF	PART #	DESCRIPTION	QTY.
1	607818	CHASSIS, BLUE	1
2	25660	AXLE, FRONT	1
3	140015	WASHER, LOCK	2
4	140223	SCREW	2
5	25656	WHEEL	2
6	103071	BEARING	2
7	140013	WASHER, FLAT	2
8	140017	WASHER, LOCK	2
9	2949.5	SCREW	2
10	25666	AXLE, REAR	1
11	4252	WASHER	2
12	4108	●WHEEL, REAR	2
13	14880.5	WASHER, FLAT	2
14	3036.10	SCREW	2
15	25715	STUD	2
16	140506	NUT	8
17	140015	WASHER, LOCK	4
18	140932	LATCH	2
19	140829	SCREW	8
20	140539	NUT	8
21	2728.14	SCREW	1
22	140042	WASHER, LOCK	1
23	25688.BK	PANEL, REAR	1
24	120649	DECAL, WARNING	1
25	140018	WASHER, LOCK	4
26	140887	SCREW	4
27	140887	SCREW	1
28	25648	SPRING	1
29	25655	PIN	1
30	25670	TUBE, HANDLE	1
31	25671	BRACKET	1
32	130729	SWITCH	1
33	27098	BRACKET, SWITCH	1
34	27099	BUSHING	1
35	25691.6	SCREW	1
36	6306.4	WASHER	1

REF	PART #	DESCRIPTION	QTY.
37	15752.14	WASHER, LOCK	1
38	14501	NUT	1
39	200823	●GRIP, HANDLE	2
40	19417	●SWITCH	1
41	130738	●LIGHT, INDICATOR	1
42	25647	●METER, PAD PRESSURE	1
43	25645	●METER, BATTERY	1
44	25644	●CIRCUIT BREAKER 70A	1
45	600652	DECAL, DASH	1
46	600394	BATTERY	2
47	600704	CABLE, (NEG)	1
48	600705	CABLE, (POS)	1
49	130367	CABLE, JUMPER	1
50	100706	PLATE, BATTERY	1
51	25726	DECAL, BATTERY CONNECTION	1
52	25646	SHUNT	1
53	15858.12	SCREW	4
54	140552	NUT	2
55	140016	WASHER, LOCK	2
56	140510	NUT	2
57	25642	●CONTACTOR, 24V	1
58	140501	NUT	2
59	6306.4	WASHER	2
60	140889	SCREW	2
61	140042	WASHER, LOCK	2
62	140539	NUT	2
63	140032	WASHER, FLAT	2
64	27833	PLUG	1
65	600736	WIRE (RED)	1
66	600737	WIRE (BLK)	1
67	140019	WASHER, STAR	2
68	2728.12	SCREW	2
69	140540	NUT	2
70	26124	DECAL, CAUTION	1
71	14880.5	WASHER, FLAT	4

● RECOMMENDED STOCK ITEMS

BRUSH DRIVE GROUP

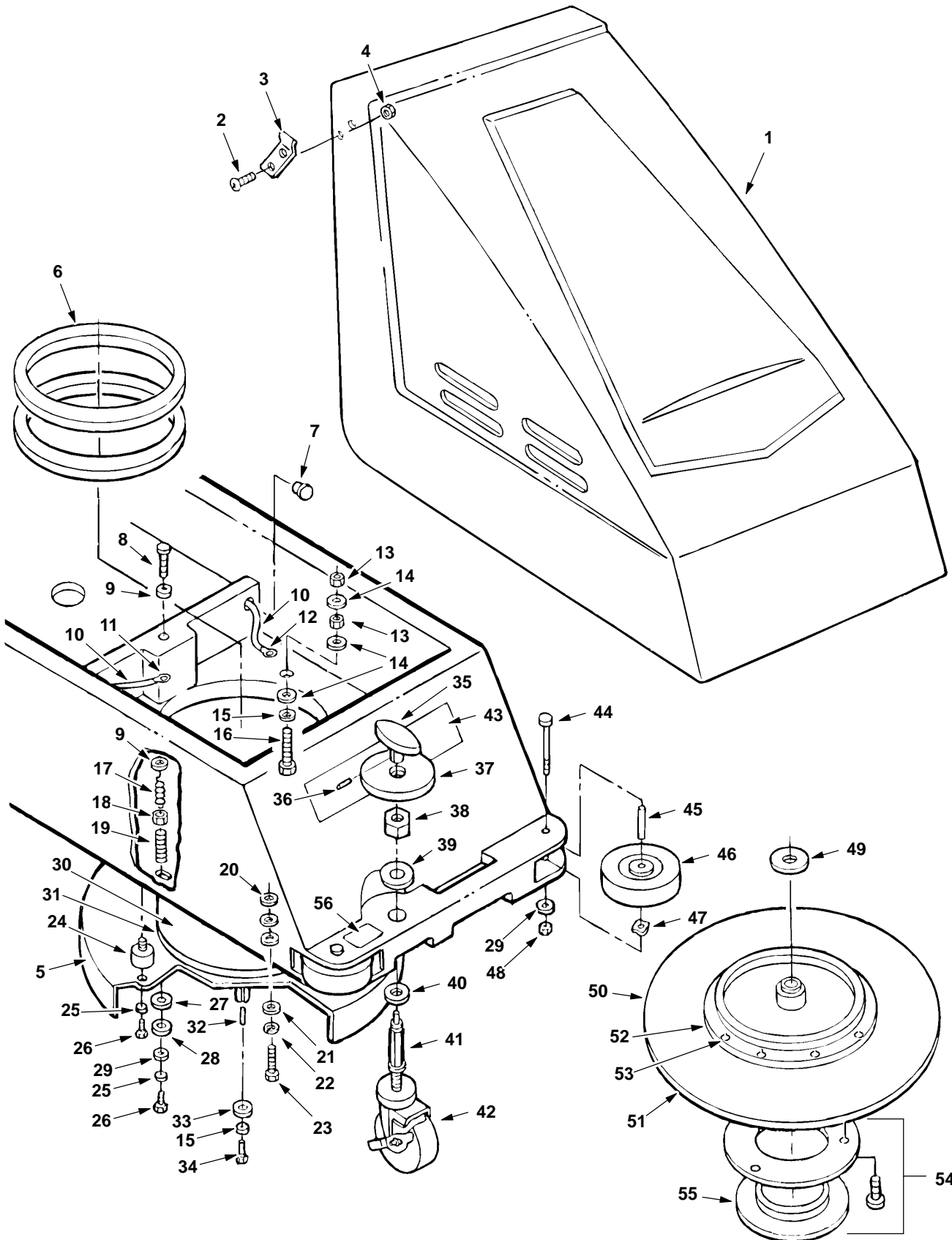

## BRUSH DRIVE GROUP

REF	PART #	DESCRIPTION	QTY.
1	607816	COVER, BATTERY, BLUE	1
2	140829	SCREW	4
3	140932	LATCH (ASM.)	2
4	140539	NUT, KEP	4
5	26656.BK	GUARD, PAD DRIVER	1
6	25675	●GASKET	2
7	15984	BUSHING	1
8	25674	SCREW	2
9	140045	WASHER, FLAT	1
10	25701	ASM., WIRE	2
11	611221	COVER, RUBBER (BLK)	1
12	611222	COVER, RUBBER (RED)	1
13	140548	NUT, JAM	2
14	140027	WASHER, FLAT	2
15	140015	WASHER, LOCK	1
16	140221	SCREW, HEX	1
17	25652	SPRING	1
18	140594	NUT, HEX	1
19	25672	SPACER, THREADED	1
20	140041	WASHER, FENDER	4
21	140010	WASHER, FLAT	1
22	140016	WASHER, LOCK	1
23	140208	SCREW, HEX	1
24	25650	MOUNT, VIBRATION	1
25	140017	WASHER, LOCK	1
26	2949.5	SCREW	1
27	140047	WASHER, FLAT	1
28	21152	GASKET	1
29	140013	WASHER, FLAT	1

REF	PART #	DESCRIPTION	QTY.
30	130479	●MOTOR, 24V	1
	512003	● CARBON BRUSH	4
31	25675	●GASKET	1
32	140628	KEY	1
33	25732	WASHER, FLAT	1
34	140203	SCREW	1
35	240202	●KNOB	1
36	140894	SCREW, SET	1
37	26812	NUT	1
38	26815	NUT	1
39	25683	WASHER, TAPERED	1
40	14880.14	WASHER, FLAT	1
41	26814	SLEEVE	1
42	26811	●CASTER	1
43	603083	DECAL, "CASTEX"	1
44	25679.20	SCREW	2
45	25657	SPACER	2
46	27527	●WHEEL, BUMPER	2
47	4252	WASHER	2
48	140515	NUT, HEX	2
49	140047	WASHER	1
∇50	27073	●ASM., PAD DRIVER	1
▲51	27071	DISC, DRIVER	1
▲52	27900	HUB, PAD DRIVER	1
▲53	190177	SCREWS & CAPS	SET
▲∇54	25707	ASM., PAD RETAINER	1
▲55	100101	●RING, PAD RETAINER	1
56	600653	DECAL, BRUSH ADJ.	1
N/S	608011	DECAL, "BR-2000"	2

∇ Assembly

▲ Included in Assembly

● Recommended Stock Items

# ELECTRICAL DIAGRAM

