

Castex[®]

PX-1000

Portable Carpet Extractor

Model No.:
607781
607794 - PAC

Operator and Parts Manual

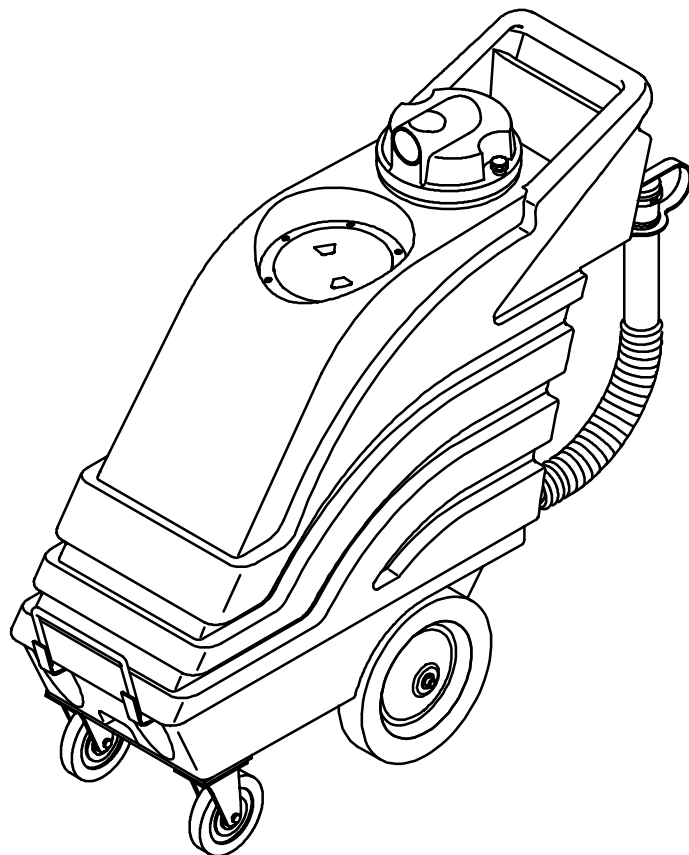

TENNANT COMPANY
701 NORTH LILAC DRIVE
MINNEAPOLIS, MN 55422

MAILING ADDRESS:
TENNANT COMPANY
P.O. BOX 1452
MINNEAPOLIS, MN 55440-1452

CASTEX CUSTOMER SERVICE:
1-800-365-6625

FAX: 1-800-678-4240

TECHNICAL SUPPORT:
1-800-522-7839 EXT. 5356

608052
Rev. 01 (03-04)

OPERATION

This manual is furnished with each new model. It provides necessary operation and maintenance instructions and an illustrated parts list.

Read this manual completely and understand the machine before operating or servicing it.

Use the illustrated Parts Lists to order parts. Before ordering parts or supplies, be sure to have your machine model number and serial number handy. Parts and supplies may be ordered by phone or mail from any authorized parts and service center, distributor or from any of the manufacturer's subsidiaries.

This machine will provide excellent service. However, the best results will be obtained at minimum costs if:

- The machine is operated with reasonable care.
- The machine is maintained regularly - per the maintenance instructions provided.
- The machine is maintained with manufacturer supplied or equivalent parts.

MACHINE DATA

Please fill out at time of installation for future reference.

Model No.- _____

Install. Date - _____

Serial No.- _____

© 1999, 2004 Tennant Company

Printed in U.S.A.

Castex is a registered United States trademark of Tennant Company.

TABLE OF CONTENTS

SAFETY PRECAUTIONS	3	TROUBLE SHOOTING	11
GROUNDING INSTRUCTIONS	4	SPECIFICATIONS	12
SAFETY LABEL	4	MACHINE DIMENSIONS	12
MACHINE COMPONENTS	5	ELECTRICAL DIAGRAMS	13
MACHINE SETUP	6	PARTS LIST	14
MACHINE OPERATION	7	RECOVERY TANK GROUP	14
PRE-OPERATION	7	CHASSIS GROUP	16
FLOOR TOOL OPERATION	7	CONTROL CONSOLE GROUP	18
OPTIONAL HAND TOOL OPERATION	8	PUMP BREAKDOWN	20
DRAINING TANKS	8	OPTIONS	21
DRAINING RECOVERY TANK	8	127mm (5 in) HAND TOOL GROUP	21
DRAINING SOLUTION TANK	9	76mm (3 in) CREVICE TOOL GROUP	21
MACHINE MAINTENANCE	9	330mm (13 in) LOW PRESSURE WAND GROUP	22
DAILY MAINTENANCE	9	406mm (16 in) LOW PRESSURE WAND GROUP	24
MONTHLY MAINTENANCE	10	UPHOLSTERY TOOL GROUP	26
QUARTERLY MAINTENANCE	10	CHEMICALS	26
SERVICING MACHINE	10	SOLUTION AND VACUUM HOSES GROUP	27
STORING MACHINE	11		
RECOMMENDED STOCK ITEMS	11		

SAFETY PRECAUTIONS

This machine is intended for commercial use. It is designed exclusively to clean carpet and upholstery in an indoor environment and is not constructed for any other use. Use only recommended accessory tools and commercially available carpet cleaners intended for machine application.

All operators must read, understand and practice the following safety precautions.

The following warning alert symbol and the "FOR SAFETY" heading are used throughout this manual as indicated in their description:

 **WARNING:** To warn of hazards or unsafe practices which could result in severe personal injury or death.

FOR SAFETY: To identify actions which must be followed for safe operation of equipment.

Failure to follow these warnings may result in: personal injury, electrocution, electrical shock, fire or explosion.

 **WARNING:** Do Not Use Flammable Liquids Or Operate Machine In Or Near Flammable Liquids, Vapors Or Combustible Dusts.

This machine is not equipped with explosion proof motors. The electric motors will spark upon start up and during operation which could cause a flash fire or explosion if machine is used in an area where flammable vapors/liquids or combustible dusts are present.

 **WARNING:** Do Not Pick Up Flammable Materials Or Reactive Metals.

 **WARNING:** Do Not Operate With Damaged Power Cord. Do Not Modify Plug. Unplug power Cord Before Servicing Machine.

If the supply cord is damaged or broken, it must be replaced by the manufacturer or it's service agent or a similarly qualified person in order to avoid a hazard.

 **WARNING:** Do Not Use Outdoors. Do Not Expose To Rain. Store Indoors.

The following information signals potentially dangerous conditions to the operator or equipment:

FOR SAFETY:

1. Do not operate machine:
 - With flammable liquids or near flammable vapors as an explosion or flash fire may occur.
 - Unless trained and authorized.
 - Unless operator manual is read and understood.
 - Unless cord is properly grounded.
 - With damaged cord or plug.
 - If not in proper operating condition.
 - In outdoor areas.
 - In standing water.
 - With the use of additional extension cords. Only use manufacturer's extension cord equipped with machine which has proper capacity and is grounded.
2. Before operating machine:
 - Make sure all safety devices are in place and operate properly.
 - Place wet floor signs as needed.
3. When using machine:
 - Do not run machine over cord.
 - Do not pull machine by plug or cord.
 - Do not pull cord around sharp edges or corners.
 - Do not unplug by pulling on cord.
 - Do not stretch cord.
 - Do not handle plug with wet hands.
 - Keep cord away from heated surfaces.
 - Report machine damage or faulty operation immediately.
 - Follow mixing and handling instructions on chemical containers
 - Never allow children to play on or around.
4. Before leaving or servicing machine:
 - Turn off machine.
 - Unplug cord from wall outlet.

OPERATION

5. When servicing machine:

- Unplug cord from wall outlet.
- Avoid moving parts. Do not wear loose jackets, shirts, or sleeves.
- Use manufacturer supplied or approved replacement parts.
- All repairs must be performed by a qualified service person.
- Do not modify the machine from its original design.

6. When transporting machine:

- Get assistance when lifting machine.
- Unplug cord from wall outlet.
- Use tie-down straps to secure machine to truck or trailer.

GROUNDING INSTRUCTIONS

Machine must be grounded. If it should malfunction or breakdown, grounding provides a path of least resistance for electrical current to reduce the risk of electrical shock. This machine is equipped with a cord having an equipment-grounding conductor and grounding plug. The plug must be plugged into an appropriate outlet that is properly installed in accordance with all local codes and ordinances. Do not remove ground pin; if missing, replace plug before use.

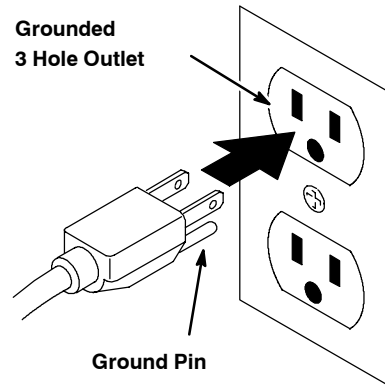

SAFETY LABEL

The safety label appears on the machine in the location indicated. Replace label if it becomes damaged or illegible.



WARNING LABEL - Located on back of machine.

WARNING FOR SAFETY: READ THE OWNER'S MANUAL BEFORE USING MACHINE.

FAILURE TO FOLLOW THESE WARNINGS MAY RESULT IN: PERSONAL INJURY, ELECTROCUTION, ELECTRICAL SHOCK, FIRE OR EXPLOSION.

 Do Not Use Flammable Liquids Or Operate Machine In Or Near Flammable Liquids, Vapors Or Combustible Dusts.	 Do Not Operate With Damaged Power Cord. Do Not Modify Plug. Unplug Power Cord Before Servicing Machine.
 Do Not Pick Up Flammable Materials Or Reactive Metals.	 Do Not Use Outdoors. Do Not Expose To Rain. Store Indoors.

613283

MACHINE COMPONENTS



- 1. Machine Lift Handle
- 2. Solution Tank
- 3. Recovery Tank
- 4. Lockable Casters
- 5. 254mm (10 in) Stair Climbing Wheels
- 6. Chemical Bottle Holder
- 7. Main Power ON/OFF Switch
- 8. Power Supply Cord Pigtail
- 9. Recovery Tank Drain Hose

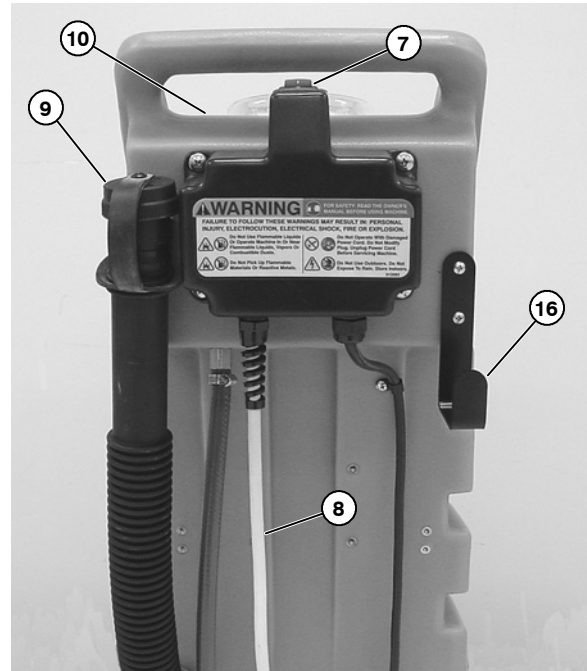

- 10. Accessory Tool Solution Hose Hookup
- 11. Accessory Tool Vacuum Hose Hookup
- 12. 4.6m (15 ft) Vacuum Hose
- 13. 4.6m (15 ft) Solution Hose
- 14. 330mm (13 in) Floor Tool (standard)
406mm (16 in) Floor Tool (optional)
- 15. 7.6m (25 ft) Power Supply Cord
- 16. Power Supply Cord Hook

OPERATION

MACHINE SETUP

1. Carefully check carton for signs of damage. Report damages at once to carrier. The machine is shipped fully assembled and is ready for use.
2. Remove solution tank lid. Using a hose or bucket, fill tank with 38L (10 gal) of hot water, 60°C (140°F) maximum (Figure 1).

NOTE: The water must **not** be hotter than 60°C (140°F) or tank damage may occur.

NOTE: If filling with a bucket be certain that bucket is clean. This will prevent possible solution line clogs.



FIG. 1

⚠ WARNING: Do Not Use Flammable Liquids Or Operate Machine In Or Near Flammable Liquids, Vapors Or Combustible Dusts.

3. Add a recommended cleaning solution.

FOR SAFETY: When using machine, follow mixing and handling instructions on chemical containers.

ATTENTION: If using powered cleaning chemicals, mix prior to adding.

NOTE: If desired, water alone achieves excellent cleaning results.

4. Replace lid securely after filling.
5. Connect the supplied extension cord to machine. Plug cord into a grounded wall outlet (Figure 2).

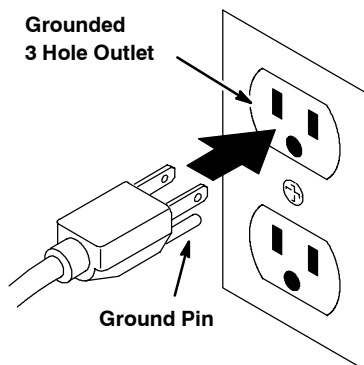

FIG. 2

FOR SAFETY: Do not operate machine unless cord is properly grounded.

FOR SAFETY: Do not operate machine with the use of additional extension cords. Only use manufacturer's extension cord equipped with machine which has proper capacity and is grounded.

6. Connect vacuum hose to recovery dome and solution hose to quick coupler located in front of handle (Figure 3).

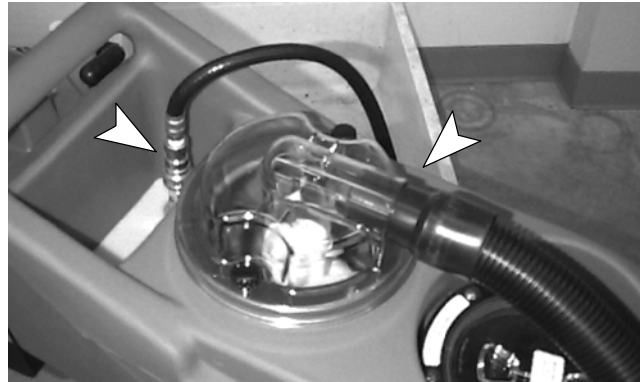

FIG. 3

7. Route hoses through front lift handle (Figure 4).



FIG. 4

NOTE: Routing hoses through handle will allow easy machine mobility while operating cleaning tool.

- Attach accessory tool to opposite end of hoses (Figure 5).

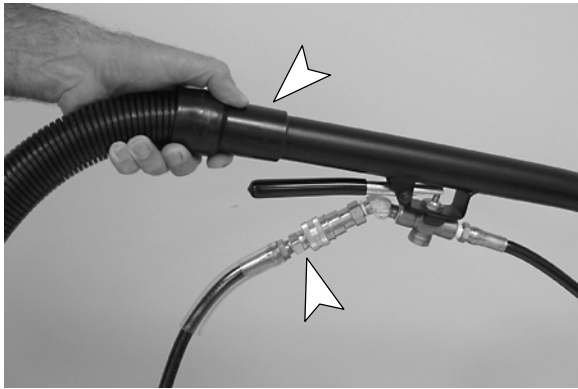

FIG. 5

- If desired, lock the front casters to keep machine stationary while cleaning (Figure 6).



FIG. 6

MACHINE OPERATION

FOR SAFETY: Do not operate machine unless operator manual is read and understood.

PRE-OPERATION

- Vacuum carpet and remove other debris.
- Perform MACHINE SETUP procedures.
- Inspect power cord for damage.

⚠ WARNING: Do Not Operate With Damaged Power Cord. Do Not Modify Plug. Unplug power Cord Before Servicing Machine.

If the supply cord is damaged or broken, it must be replaced by the manufacturer or its service agent or a similarly qualified person in order to avoid a hazard.

FLOOR TOOL OPERATION

- Activate ON/OFF switch to "ON".
- Place floor tool so bottom of stainless steel shoes are parallel to floor. Squeeze trigger and apply downward pressure on floor tool head and slowly pull tool backwards using both hands. Release trigger 150 mm (6 in) from end of stroke (Figure 7).

⚠ WARNING: Do Not Pick Up Flammable Materials Or Reactive Metals.



FIG. 7

- Push floor tool forward over same path with trigger released when returning for next stroke. Continue this pull and push method with a slight overlap of each stroke.

NOTE: For heavily soiled areas, repeat stroke or change angle of stroke.

- Check for excessive foam buildup in recovery tank. Use a recommended foam control solution to prevent vacuum motor damage.

ATTENTION: Excessive foam buildup will not activate the float shut-off screen. Vacuum motor damage may result.

- When finished cleaning, turn off switch and drain recovery tank (See DRAINING RECOVERY TANK).
- After cleaning, relieve water pressure from accessory tool before disconnecting hose. Squeeze trigger for five seconds after turning off the main power switch.

OPERATION

OPTIONAL HAND TOOL OPERATION

NOTE: This machine cleans most synthetic upholstery very well. Extraction is not recommended for most cottons, silks, wools or natural fiber velvets. Check cleaning instructions sewn in furniture by manufacturer for further instructions. Extra caution should be taken with furniture that has been reupholstered. Any material under new upholstery may bleed and discolor new fabric.

NOTE: Vacuum upholstery before cleaning.

1. TEST FABRIC FOR COLORFASTNESS. Pour a small amount of cleaning solution on a white cloth and hold damp portion of cloth against an area of upholstery which is hidden from view. Hold it there for 60 seconds. If no color transfers to the cloth, it should be safe to clean. However, always use your best judgement.
2. Activate ON/OFF switch to "ON".
3. Hold tool 150-200 mm (6-8 inches) above fabric and squeeze trigger to spray cleaning solution (Figure 8).



FIG. 8

4. Place tool on fabric and slowly pull tool backwards.

NOTE: Be careful not to over wet upholstery. Overlap strokes to avoid streaking. Repeat stroke using only vacuum to get fabric as dry as possible.

⚠ WARNING: Do Not Pick Up Flammable Materials Or Reactive Metals.

ATTENTION: Do not allow water or foam to enter float shut-off screen in recovery tank.

5. When finished cleaning, turn off switches and drain recovery tank (See DRAINING RECOVERY TANK).
6. After cleaning, relieve water pressure from tool before disconnecting hose. Squeeze trigger for five seconds after turning main power switch off.

DRAINING TANKS

FOR SAFETY: Before leaving or servicing machine, unplug power cord from wall outlet.

DRAINING RECOVERY TANK

1. Turn switch off and disconnect power cord.
2. Remove the drain hose cap while holding the hose up, then slowly lower the drain hose to the drain or sink (Figure 9).



FIG. 9

NOTE: If using a bucket to drain machine, do not use same bucket for filling solution tank. This will prevent possible solution line clogs.

3. After draining, replace drain hose cap securely.
4. After final draining, remove recovery dome and rinse both tank and dome thoroughly to prevent odor buildup.

DRAINING SOLUTION TANK

1. Connect one end of the 4.6m (15 ft) vacuum hose supplied with machine to the recovery dome (Figure 10).



FIG. 10

2. Turn on Vacuum/Pump switch.
3. Remove solution tank lid and vacuum out leftover solution.
4. Drain recovery tank.

MACHINE MAINTENANCE

To keep machine in good working condition, simply follow machines daily and monthly maintenance procedures.

FOR SAFETY: When servicing machine, unplug cord from wall outlet.

DAILY MAINTENANCE (Every 4 Hour of Use)

1. Drain and rinse out recovery tank thoroughly.

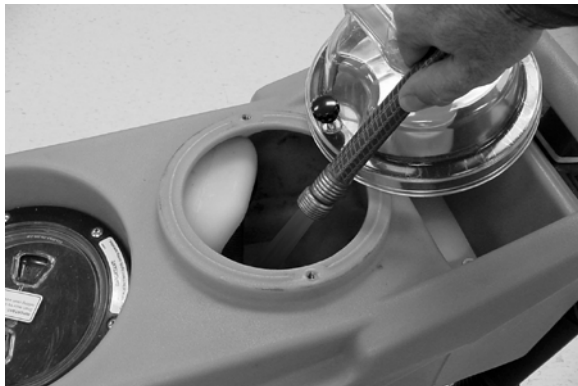

FIG. 11

2. Remove and clean float shut-off screen, located in recovery tank (Figure 12).



FIG. 12

3. Vacuum out the leftover solution from the solution tank (Figure 13).



FIG. 13

4. Remove and rinse solution tank screen (Figure 14).



FIG. 14

5. Inspect the accessory tool spray pattern for plugging. If plugged, remove the spray tips and screens and soak them in acetic acid solution for up to six hours. Do not use pointed objects to unplug tips, damage will occur (Figure 15).

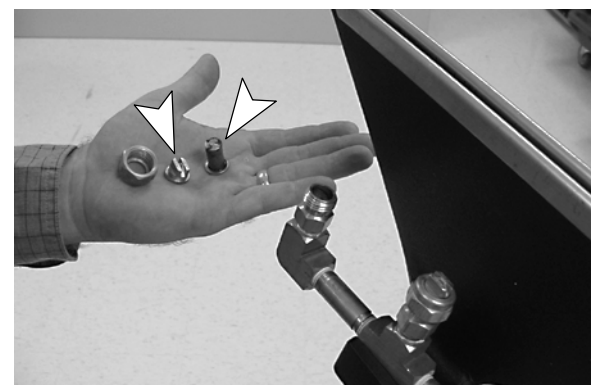

FIG. 15

OPERATION

6. Remove any clogged debris in the accessory tool (Figure 16).



FIG. 16

7. Inspect cord and cord grip for damage, replace if damaged. Coil cord neatly after each use.

⚠ WARNING: Do Not Operate With Damaged Power Cord. Do Not Modify Plug. Unplug power Cord Before Servicing Machine.

If the supply cord is damaged or broken, it must be replaced by the manufacturer or its service agent or a similarly qualified person in order to avoid a hazard.

8. Clean machine with a nonabrasive, nonsolvent cleaner.

ATTENTION: Do not power spray or hose off machine. Electrical component damage due to water is not covered by warranty.

9. Inspect vacuum hose for holes and loose cuffs.

MONTHLY MAINTENANCE (Every 80 Hours of Use)

1. Flush pump system. Use acetic acid solution to dissolve normal alkaline chemical buildup. Follow these steps.

FOR SAFETY: When using machine, follow mixing and handling instructions on chemical containers.

- a. Premix .5L (16 oz) of an acetic acid solution with 7.5L (2 gal) of hot water 60° C (140° F) and pour into solution tank.

NOTE: The water must *not* be hotter than 60° C (140° F) or tank damage may occur.

- b. Place a bucket under spray jets to catch spray.
- c. Turn on switch.
- d. Squeeze trigger on tool for 30 seconds.
- e. Allow solution to remain in system for up to 6 hours in above freezing temperatures.
- f. Later, spray out solution into a bucket or drain. Then run 11 L (3 gal) of clean water through system to flush out impurities.

2. Lubricate casters with a water resistant oil.
3. Inspect machine for water leaks.
4. Inspect machine for loose screws.

QUARTERLY MAINTENANCE (Every 250 Hours of Use)

Check motor for carbon brush wear, replace brushes if worn to a length of 10mm (0.38 in) or less.

Contact your Authorized Service Center for carbon brush inspection.

FOR SAFETY: When servicing machine all repairs must be performed by a qualified service person.

SERVICING MACHINE

To access internal components for repair, open machine as described below.

FOR SAFETY: When servicing machine, unplug cord from wall outlet.

FOR SAFETY: When servicing machine, use manufacturer supplied or approved replacement parts.

1. Remove two hex-head bolts at front of machine, using a 9/16" wrench.

ATTENTION: Make sure tanks are empty before opening.

2. Carefully hinge tank backwards away from chassis (Figure 17).

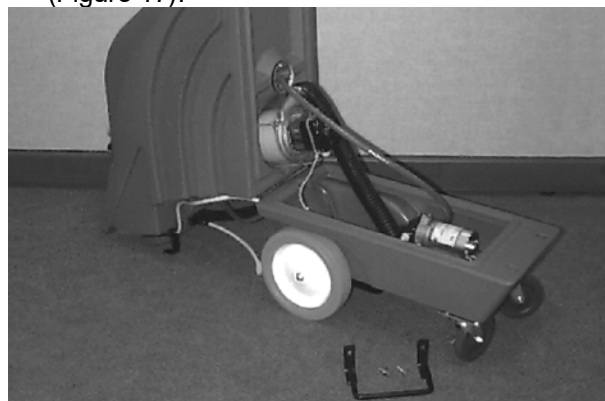

FIG. 17

STORING MACHINE

1. Before storing machine, be certain to flush tanks and drain machine of all water.
2. Store machine in a dry area in the upright position.
3. Remove recovery dome to promote air circulation.

⚠ WARNING: Do Not Use Outdoors. Do Not Expose To Rain. Store Indoors.

ATTENTION: If storing machine in freezing temperatures, be sure that machine and solution system are completely drained and dry.

RECOMMENDED STOCK ITEMS

Refer to Parts List section for recommended stock items. Stock Items are clearly identified with a bullet preceding the parts description. See example below:

Ref.	Part No.	Description	Qty.
1	201103	ASM., STANDPIPE	1
2	180618	● FLOAT, SHUTOFF	1
3	230197	NIPPLE	1
4	101714	● GASKET	1
5	210240	NUT, FLANGED	1

TROUBLE SHOOTING

PROBLEM	CAUSE	SOLUTION
No power.	Faulty ON/OFF switch.	Contact Service Center.
	Faulty wiring.	Contact Service Center.
	Faulty power cord.	Replace power cord.
Solution pump will not operate.	Pump overheated.	Determine cause and let pump cool for 20 minutes.
	Faulty switch.	Contact Service Center.
	Loose or broken wiring.	Contact Service Center.
	Faulty solution pump.	Contact Service Center.
	Faulty ON/OFF switch.	Contact Service Center.
Poor or no vacuum suction.	Vacuum thermal overload tripped.	Check air flow for obstruction, wait 20 minutes for motor to cool.
	Faulty ON/OFF switch.	Contact Service Center.
	Drain hose cap open or loose.	Cap drain hose securely.
	Lint clogging ball float screen.	Remove recovery dome and clean lint off screen.
	Air leakage around dome.	Tighten recovery dome knobs.
	Vacuum hose connections are loose.	Secure connections.
	Damaged vacuum hose or cuffs are loose.	Replace hose or secure cuffs to hose.
	Defective vacuum motor.	Contact Service Center.
	Worn carbon brushes.	Replace brushes or call for service.
Uneven or no spray from tool.	Dirty or plugged spray tips.	Clean or replace tips.
	Improper spray tip size or spray angle.	Replace with proper tips.
	Worn spray tips.	Replace spray tips.
	Loose or broken wiring.	Contact Service Center.
Leaking floor tool.	Quick coupler on floor tool faulty.	Replace quick coupler.
	Flow control valve leaking.	Install valve rebuild kit or contact Service Center.
	Hose split or fittings loose.	Replace hose and tighten fittings.
	Quick coupler and plug not fully engaged.	Reconnect quick coupler.
	Valve stem worn.	Replace or contact Service Center.

OPERATION

SPECIFICATIONS

Model	PX-1000
LENGTH	1054.1 mm (41.5 in)
WIDTH	330.2 mm (13 in)
HEIGHT	965.2 mm (38 in)
MACHINE WEIGHT	36Kg (80lbs)
SOLUTION TANK CAPACITY	37.8L (10 gal)
RECOVERY TANK CAPACITY	54.8L (14.5 gal)
SOLUTION PUMP	120 volt, 100 psi, 1 amp
SOLUTION FLOW RATE	Floor Tool with 3 tips = 3.8L (1 gal) per minute 127 mm (5 in) Hand Tool with 1 tip = 1L (32 oz) per minute
VACUUM MOTOR	120 volt, 3-stage, 1.66 hp, 13 amp, 1513 watts
SEALED WATER LIFT	3.5m (137 in)
DECIBEL RATING AT OPERATOR'S EAR, INDOORS ON CARPET	80dB(A)

MACHINE DIMENSIONS

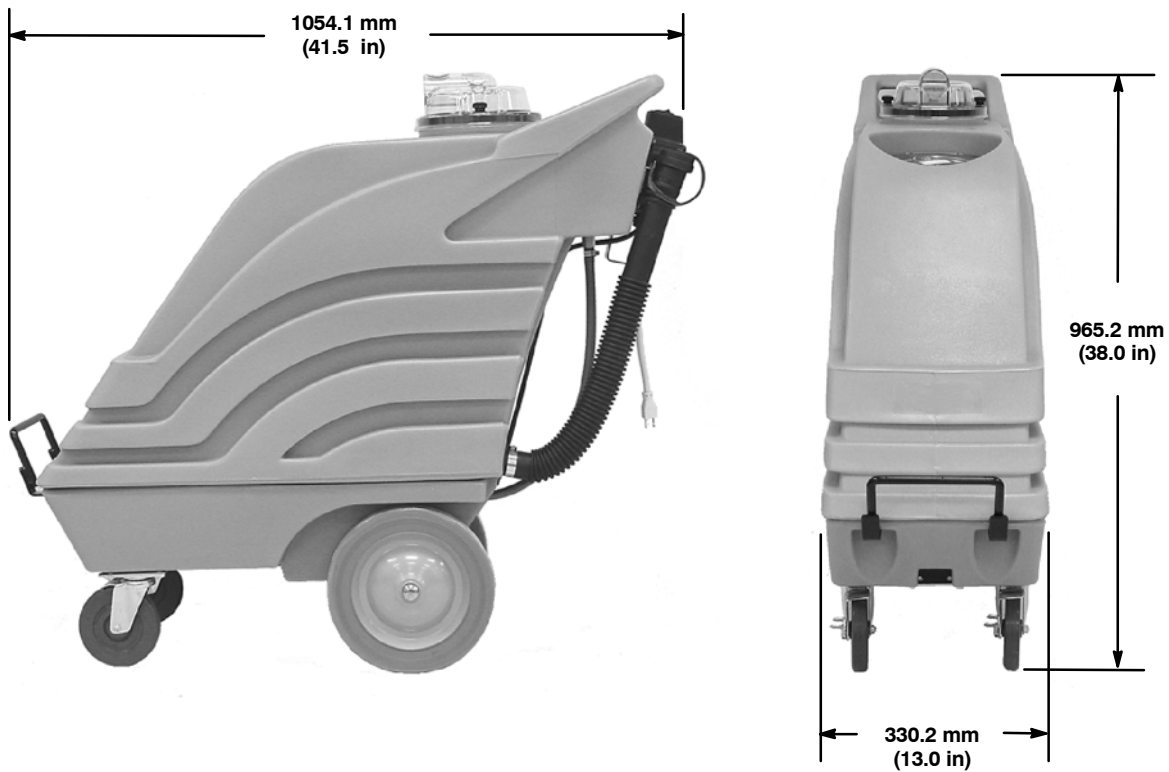

120V WIRING DIAGRAM

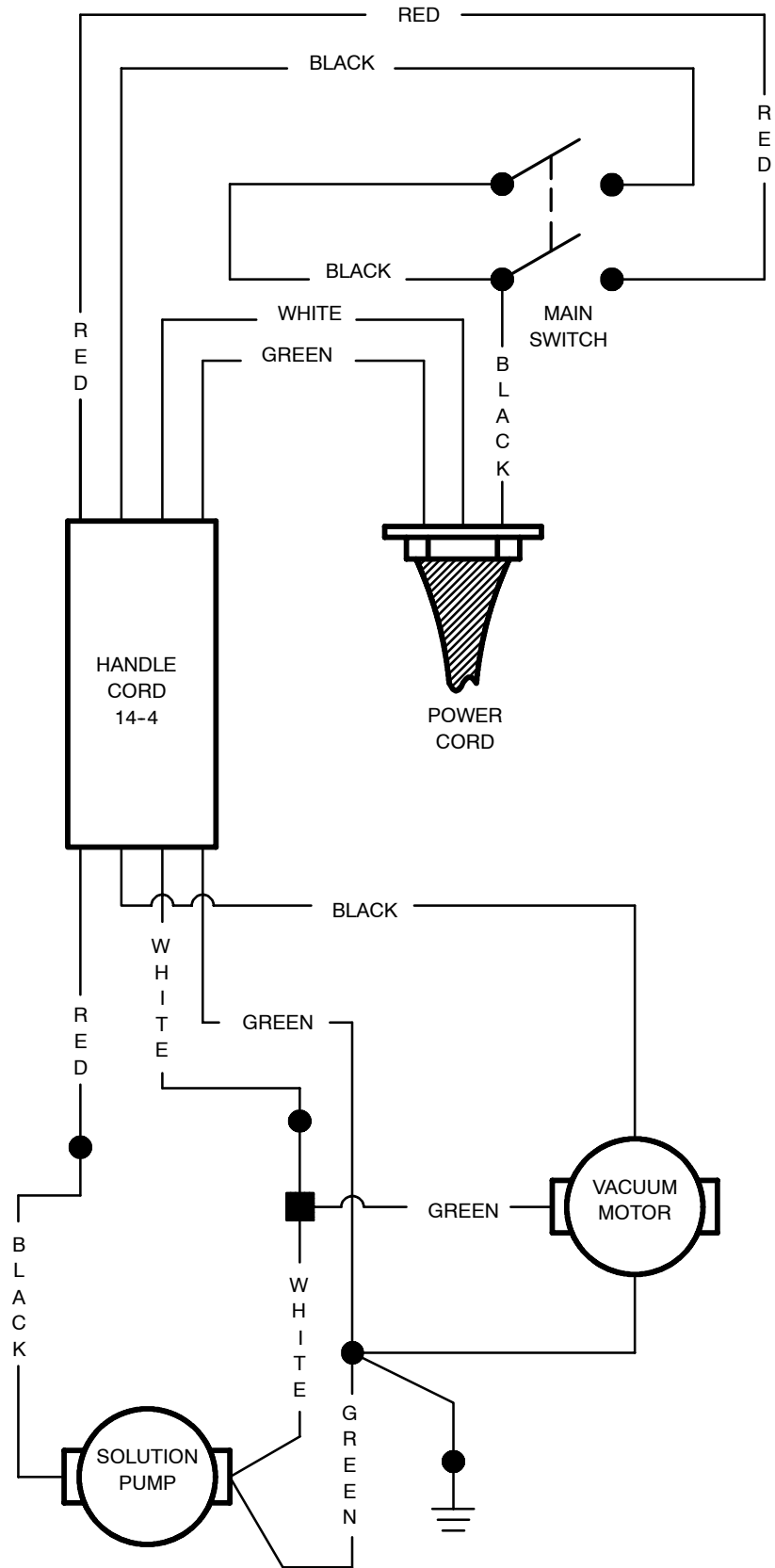

RECOVERY TANK GROUP

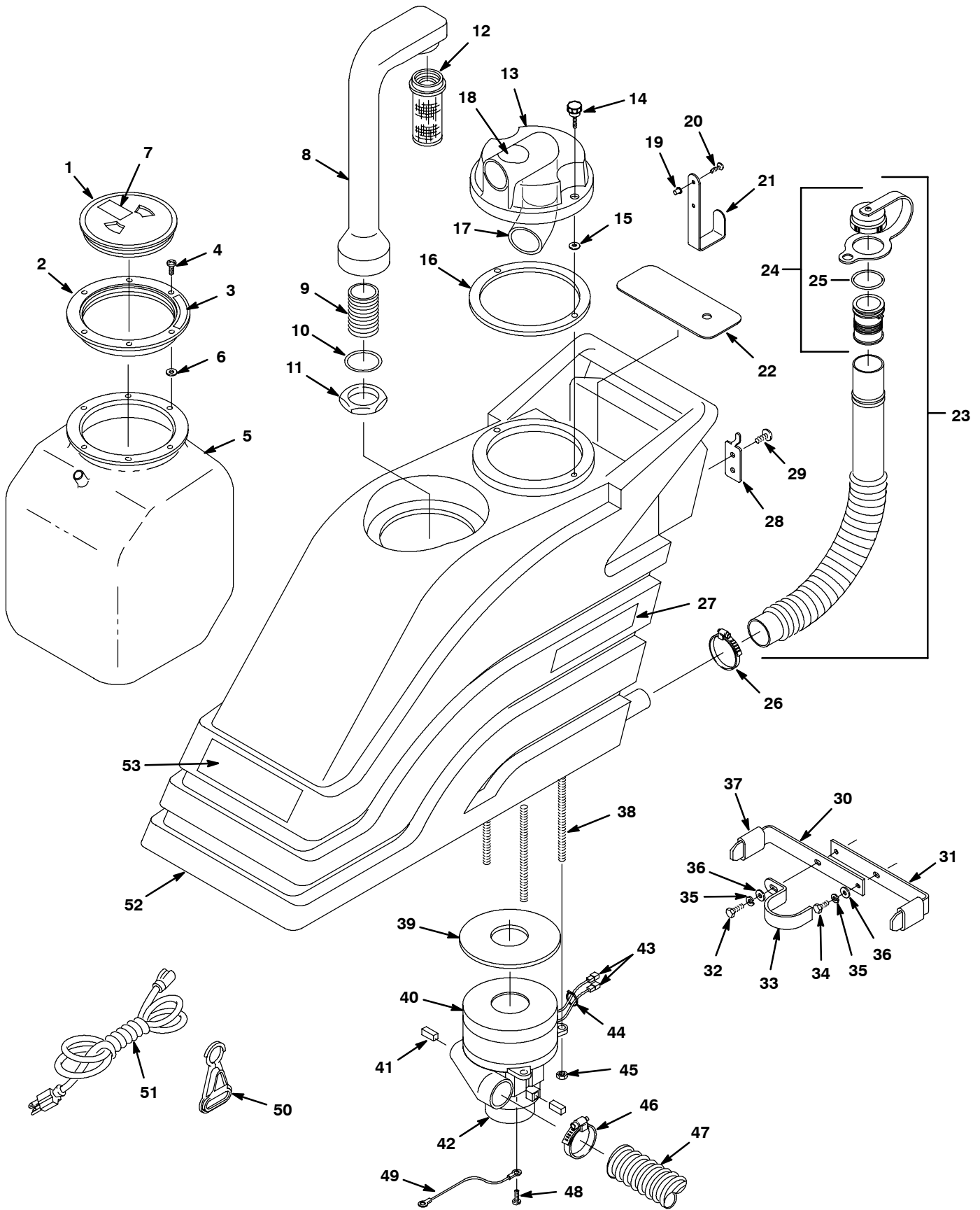

RECOVERY TANK GROUP

REF	PART #	DESCRIPTION	QTY.
▽	100103	●ASM., LID CLEAR	1
▲ 1	100105	LID, CENTER ONLY CLEAR	1
▲ 2	600812	LID, OUTER RING ONLY	1
3	120907	LABEL, IMPORTANT CLOSE	1
4	140900	SCREW, TRS 10-24 X 0.75	6
5	602715	BAG, SOLUTION BLADDER	1
6	140000	WASHER, FLAT 0.28B 0.62D .04	6
7	120906	LABEL, IMPORTANT DRAIN	1
▽ 8	602448	STANDPIPE, W/NIPPLE	1
▲ 9	606088	FITTING, 1-1/2" NIPPLE CPVC	1
10	230159	O-RING, STANDPIPE	1
11	210240	NUT, FLANGED METAL 1-1/2 FPT	1
12	180613	●FLOAT, SHUT-OFF (1) BALL	1
▽	701005	ASSEMBLY, DOME	1
▲ 13	100112	DOME, VACUUM	1
▲ 14	240217	KNOB, DOME	2
▲ 15	140037	WASHER, NYLON	2
▲ 16	100042	●GASKET, RECOVERY DOME	1
▲ 17	230834	FITTING 1-1/2SX1-1/2S45 PVC-40	1
▲ 18	120399	LABEL, "DO NOT ALLOW FOAM"	1
19	140637	NUT, 10-32 WELL	2
20	140877	SCREW, PAN #10-32 X 1.25 PHL	2
21	230755.BK	HOOK, CORD HANGER BLK	1
22	230489	PLATE, BOTTLE SUPPORT	1
▽ 23	1007072	●ASM., DRAIN HOSE	1
▲▽ 24	1008639	●ASM., CAP, DRAIN HOSE	1
▲ 25	1008637	●O-RING, 1.48"ID X 1.76"OD	1
26	614157	CLAMP, HOSE 27MM TO 51MM	1
27	608053	DECAL, PX-1000 SIDE	2

▽ ASSEMBLY

▲ INCLUDED IN ASSEMBLY

● RECOMMENDED STOCK ITEMS

REF	PART #	DESCRIPTION	QTY.
28	1006890	BRACKET, HOSE HANGER	1
29	140826	SCREW, PAN #6-32X0.75 PHL	2
30	230844	BRACKET, W/HOLES TANK BRACE	1
31	230843	BRACKET, W/THDS TANK BRACE	1
32	140259	SCREW, HEX .25-20 X .62	1
33	230955	CLAMP, TANK BRACE	1
34	01696	SCREW, HEX .25-20 X .50	1
35	140016	WASHER, 1/4 LOCK	2
36	140000	WASHER, FLAT 0.28B 0.62D .04	2
37	102569	GRIP, FOAM BLACK	1
38	140227	SCREW, STUD, 1/4-20X5	3
39	100118	●GASKET, VACUUM MOTOR	1
▽ 40	130996	●MOTOR, VACUUM 5.7 3STG 120V	1
	130130	TERMINAL, RING #10 22-18 NI	1
▲ 41	602741	●BRUSH, CARBON W/HLDR (2/PK)	1
▲ 42	130486	●FAN SHELL, 5.7" MOTOR	1
43	281004001	TERMINAL, FEMALE .25 RED	2
44	130040	WIRE TIE	2
45	41169	NUT, NYLOCK, 1/4-20	4
46	140308	CLAMP, HOSE	2
47	606160	●HOSE, EXHAUST 2"X24"	1
48	140897	SCREW, HEX 10-32 X 1/4 SLOT	1
49	700680	ASM., WIRE #16X12" GRN 10X10	1
50	130176	●CLIP, CORD STRAIN-RELIEF (OPTIONAL)	1
51	130694	●CORD, 14/3X25' YELLOW EXT.	1
52	601349	TANK, RECOVERY BLUE	1
53	120101	LABEL, LOGO CASTEX WHT MED	1

CHASSIS GROUP

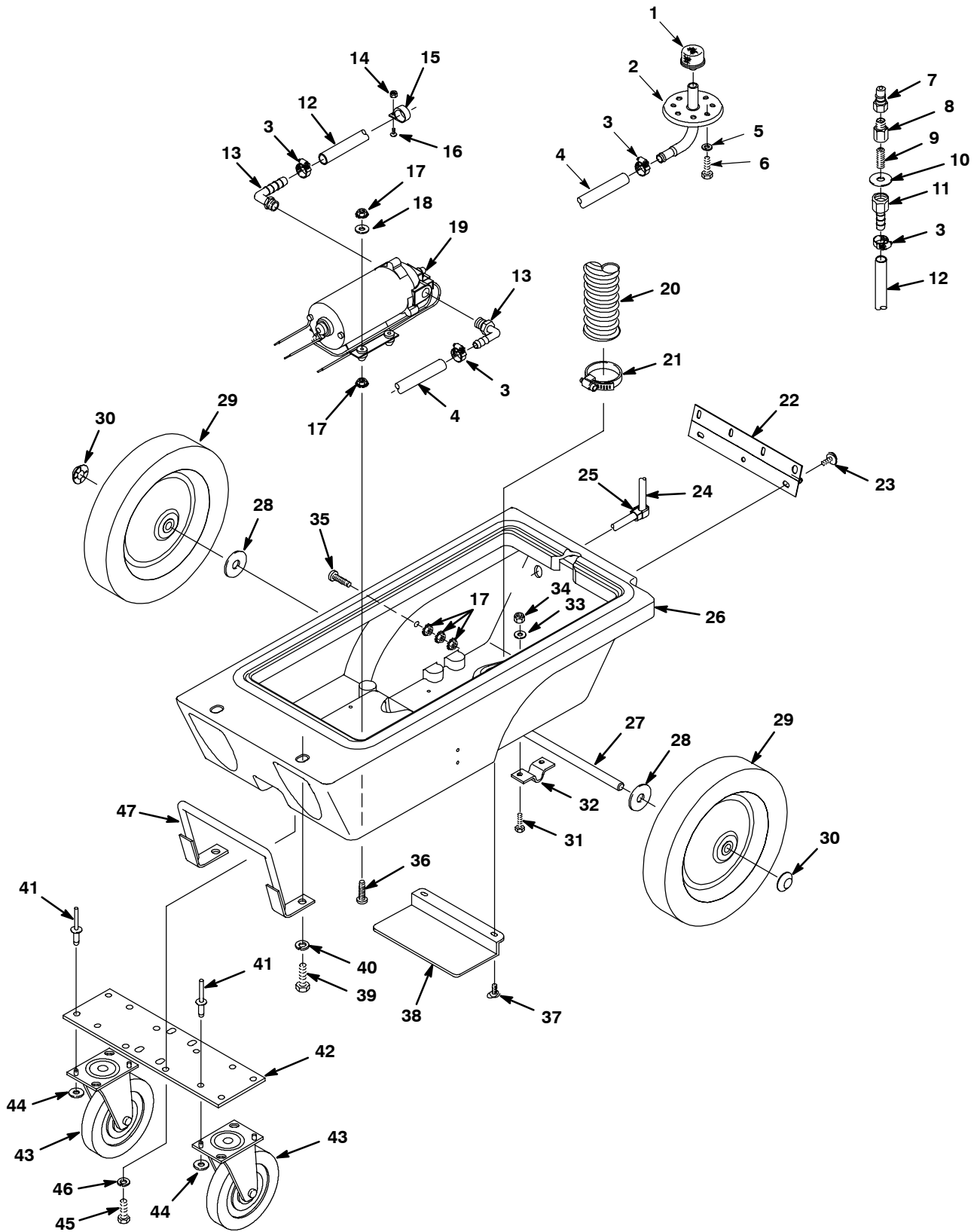

CHASSIS GROUP

REF	PART #	DESCRIPTION	QTY.
1	180628	●FILTER, SCREEN 100 MESH	1
2	600451	FITTING, BAG BLADDER PLATE	1
3	54333	CLAMP, HOSE WORM 0.31-0.88D	4
4	607305	HOSE, 3/8ID X 5/8OD X 30" GRAY	1
5	140016	WASHER, LOCK .25	4
6	01696	SCREW, HEX .25-20 X 0.50	4
7	150933	●FITTING, CPLR 1/4F ML SER60	1
8	150000	ADAPTER, 1/4FX1/4M	1
9	150600	NIPPLE, 1/4"X2"	1
10	140008	WASHER, FLAT	1
11	150511	FITTING, BARB 1/4FX3/8H	1
12	613495	HOSE, 3/8ID X 5/8OD X 39.96" GRAY	1
13	150412	FITTING, PLSTC E90 PM06/BM06	2
14	140552	NUT, HEX 10-24 NYLON	1
15	140916	CLAMP, CABLE 5/8ID NYLON	1
16	140823	SCREW, TRS 10-24 X 0.62 PHL	1
17	140519	NUT, KEP 10-24	11
18	19066	WASHER, FLAT #10	4
19	180103	●PUMP, SOL 100PSI 120V	1
	130096	CONNECTOR ASSY, BLADE ML .25	1
	130125	TERMINAL, RING #10 16-14 NI	1
20	606160	●HOSE, EXHAUST 24"	1
21	140308	CLAMP, HOSE 1-5/16 TO 2-1/4	1
22	230390	HINGE, SOL. REC. TANK	1
23	140885	SCREW, TRS .25-20 X 0.50 PHL	7

● RECOMMENDED STOCK ITEMS

REF	PART #	DESCRIPTION	QTY.
24	602616	CORD, 16/3 X 47	1
25	130181	GRIP, CORD STRAIN-RELIEF 1/2NPT	1
26	602764	CHASSIS, BLUE	1
27	230739	AXLE, WHEEL 1/2DX 13-1/8L	1
28	140008	WASHER, FLAT .57BX1.28DX.080	2
29	103068	●WHEEL, TRANSPORT 10"X1.75	2
30	103019	CAP, HUB WHEEL 0.5ID	2
31	24672	SCREW, HEX .25-20X.75	4
32	230746	BRACKET, AXLE 1/2DIA OFFSET	2
33	140000	WASHER, FLAT 1/4	4
34	41169	NUT, HEX LOCK .25-20 NYLON	4
35	140804	SCREW, RND 10-24 X 1 PHL	1
36	1014262	SCREW, PAN 10-24 X 1.50 PHL	4
37	140885	SCREW, TRS .25-20 X 0.50 PHL	2
38	231035.BK	PLATE, VACUUM EXHAUST	1
39	140231	SCREW, HEX .38-16 X 1.50	2
40	140017	WASHER, LOCK SPLIT 0.38	2
41	140701	RIVET, BLIND .250D X 0.13 X .25D	8
42	231034	PLATE, CASTER MOUNT	1
43	103004	●CASTER, SWIVEL 5"X1" GRAY	2
44	579210	WASHER, FLAT M6.4 X 18 X 1.5	8
45	02991	SCREW, HEX .38-18 X 0.75	4
46	140015	WASHER, LOCK SPLIT .31	4
47	231026.BK	HANDLE, LIFT WELDMENT BLACK	1

CONTROL CONSOLE GROUP

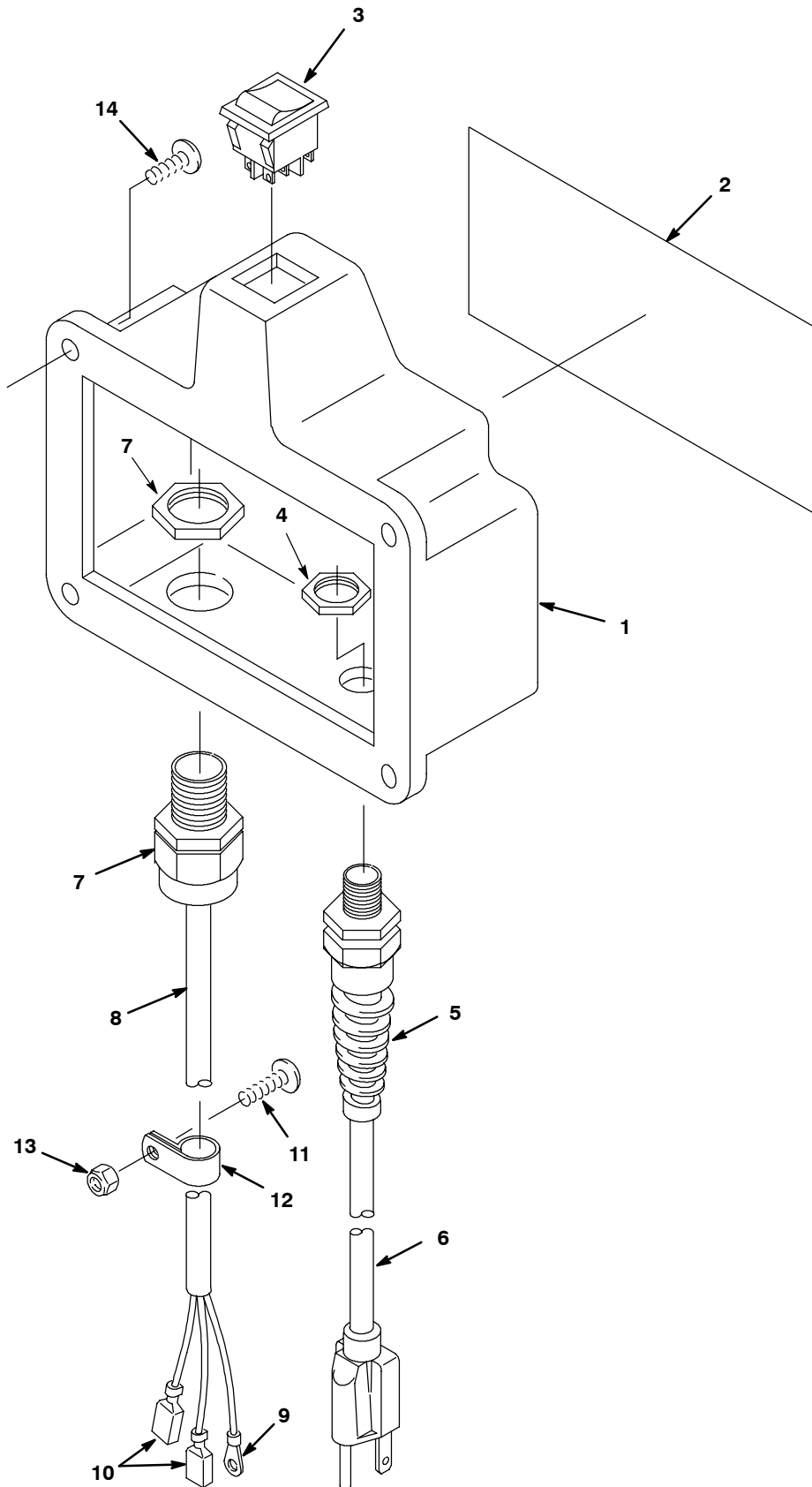

CONTROL CONSOLE GROUP

REF	PART #	DESCRIPTION	QTY.
▽	608815	ASM., SWITCHBOX BLACK	1
▲▽ 1	608515	SWITCHBOX, BLACK W/LABEL	1
▲ 2	613283	LABEL, WARNING AC EXTR 6X2.25	1
▲ 3	602669	●SWITCH, ROCKER 120VAC 20A	1
▲ 4	140504	NUT, CONDUIT 1/2 NPT LOCK	1
▲ 5	130181	●GRIP, CORD STRAIN-RELIEF 1/2N	1
▲ 6	130227	●CORD, 14/3X20" YELLOW SMOOTH	1
▲ 7	130166	●GRIP, STRAIN-RELIEF W/NUT	1
▲ 8	602616	CORD, 16/3X47 BLACK	1

▽ ASSEMBLY

▲ INCLUDED IN ASSEMBLY

● RECOMMENDED STOCK ITEMS

N/S = NOT SHOWN

REF	PART #	DESCRIPTION	QTY.
▲ 9	281001009	●TERMINAL, RING #10 14-16	1
▲ 10	130097	●TERMINAL, FEM .25 16-14 FI BL	2
11	140823	SCREW, TRS 10-24 X 0.62 PHL	2
12	140328	CLAMP, CABLE 3/8ID BLACK NY	2
13	140552	NUT, HEX 10-24 NL	2
14	140885	SCREW, TRS .25-20X0.50 PHL	4
N/S	130040	TIE, WIRE 6"X.12 NY	2

PUMP BREAKDOWN

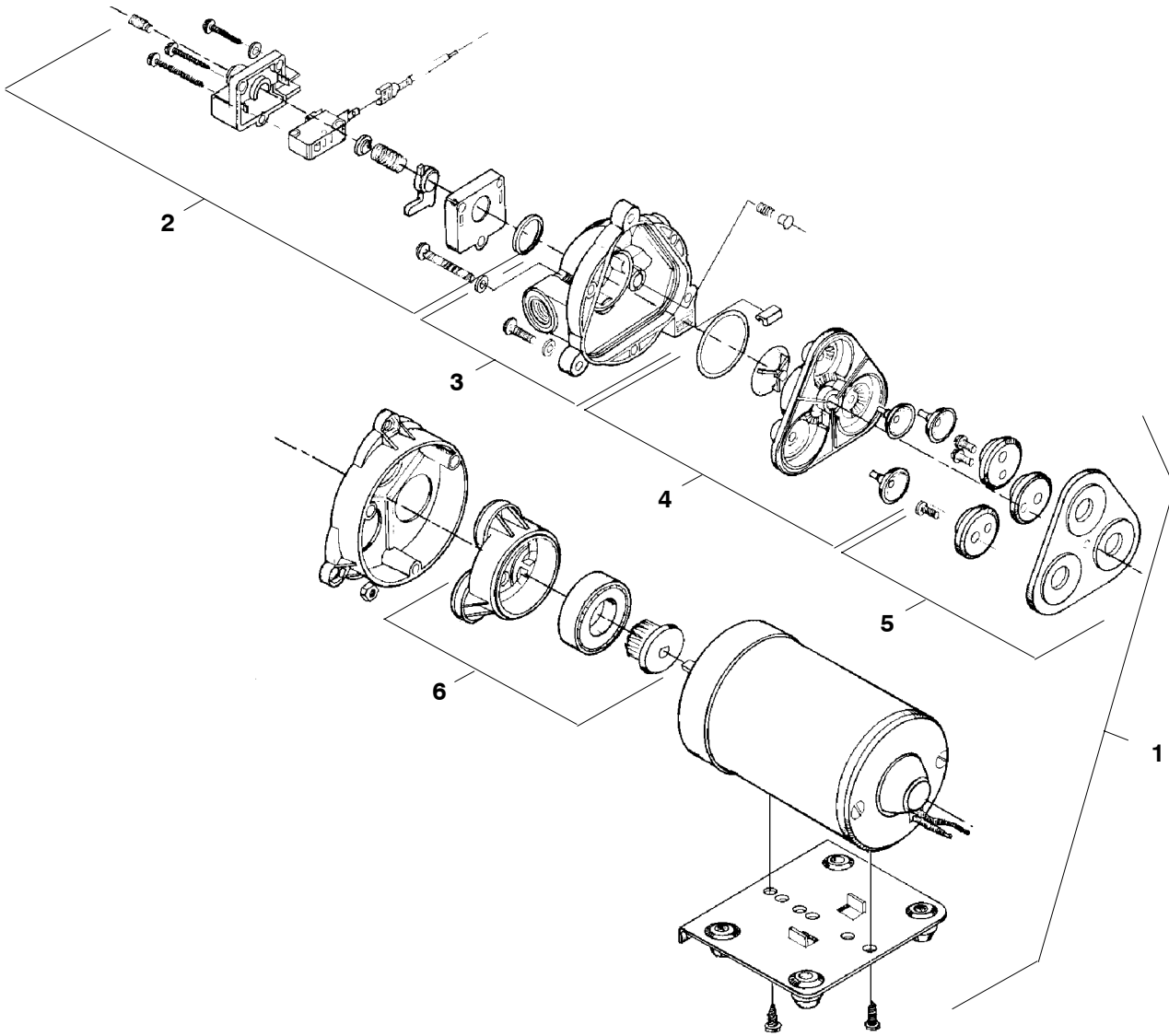

REF	PART #	DESCRIPTION	QTY.
1	180103	●PUMP, SOLUTION 100PSI 120V	1
2	190129	●KIT, PRESSURE SWITCH	1
	190172	●KIT PRESSURE SWITCH (VITON)	1
	190134	●KIT, DIAPHRAGM ONLY	1

● RECOMMENDED STOCK ITEMS

REF	PART #	DESCRIPTION	QTY.
3	190128	●KIT, UPPER PUMP HOUSING	1
	190124	●KIT, CHECK VALVE ONLY	1
4	190171	●KIT, VALVE (VITON)	1
5	190131	●KIT, SERVICE	1
6	190130	●KIT, LOWER PUMP HOUSING	1

127mm (5 in) HAND TOOL GROUP

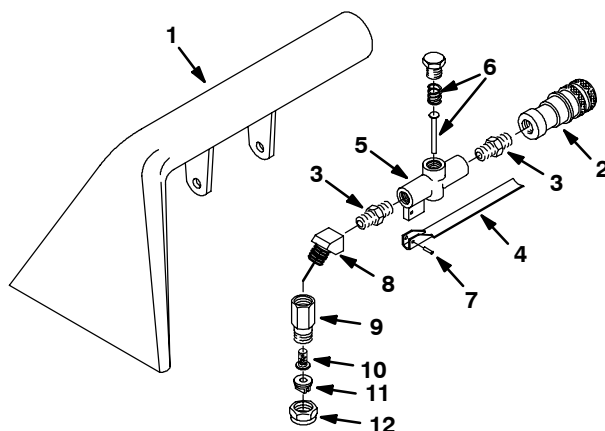

REF	PART #	DESCRIPTION	QTY.
∇	200505	●ASM., HAND TOOL 5"	1
▲ 1	200431.BK	TOOL, HAND	1
▲ 2	150913	●FITTING, 1/4F QD FML COUPLER	1
▲ 3	150606	NIPPLE, HEX 1/4	2
▲ 4	200905	TRIGGER, HAND TOOL	1
▲ 5	210210	●VALVE, FLOW CONTROL	1
▲ 6	190600	●VALVE PIN & SPRING	1

REF	PART #	DESCRIPTION	QTY.
▲ 7	140609	PIN, ROLL 3/16	1
▲ 8	150403	ELBOW, ST 1/4 45°	1
▲ 9	200992	BODY, SPRAY 1/4F	1
▲ 10	200996	●SCREEN, SPRAY NOZZLE	1
▲ 11	200965	●TIP, SPRAY #8002	1
▲ 12	200994	CAP, SPRAY BODY	1

76mm (3 in) CREVICE TOOL GROUP

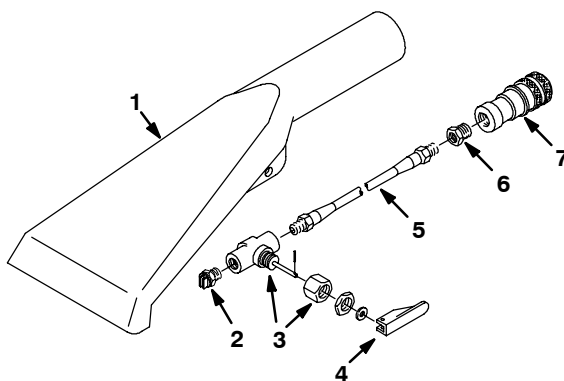

REF	PART #	DESCRIPTION	QTY.
∇	200517	●ASM., CREVICE TOOL SER. 60	1
▲ 1	200436.BK	TOOL, CREVICE BLACK	1
▲ 2	200975	●FITTING, TIP #5002 V-JET	1
▲ 3	210014	●VALVE, TOGGLE W/NUT	1

REF	PART #	DESCRIPTION	QTY.
▲ 4	210020	POSITIONER, VALVE HANDLE	1
▲ 5	160106	HOSE, SOLUTION	1
▲ 6	150100	FITTING, 1/4MX1/8F BUSHING	1
▲ 7	150913	FITTING, 1/4F QD FML COUPLER	1

∇ ASSEMBLY

▲ INCLUDED IN ASSEMBLY

● RECOMMENDED STOCK ITEMS

330mm (13 in) LOW PRESSURE WAND GROUP

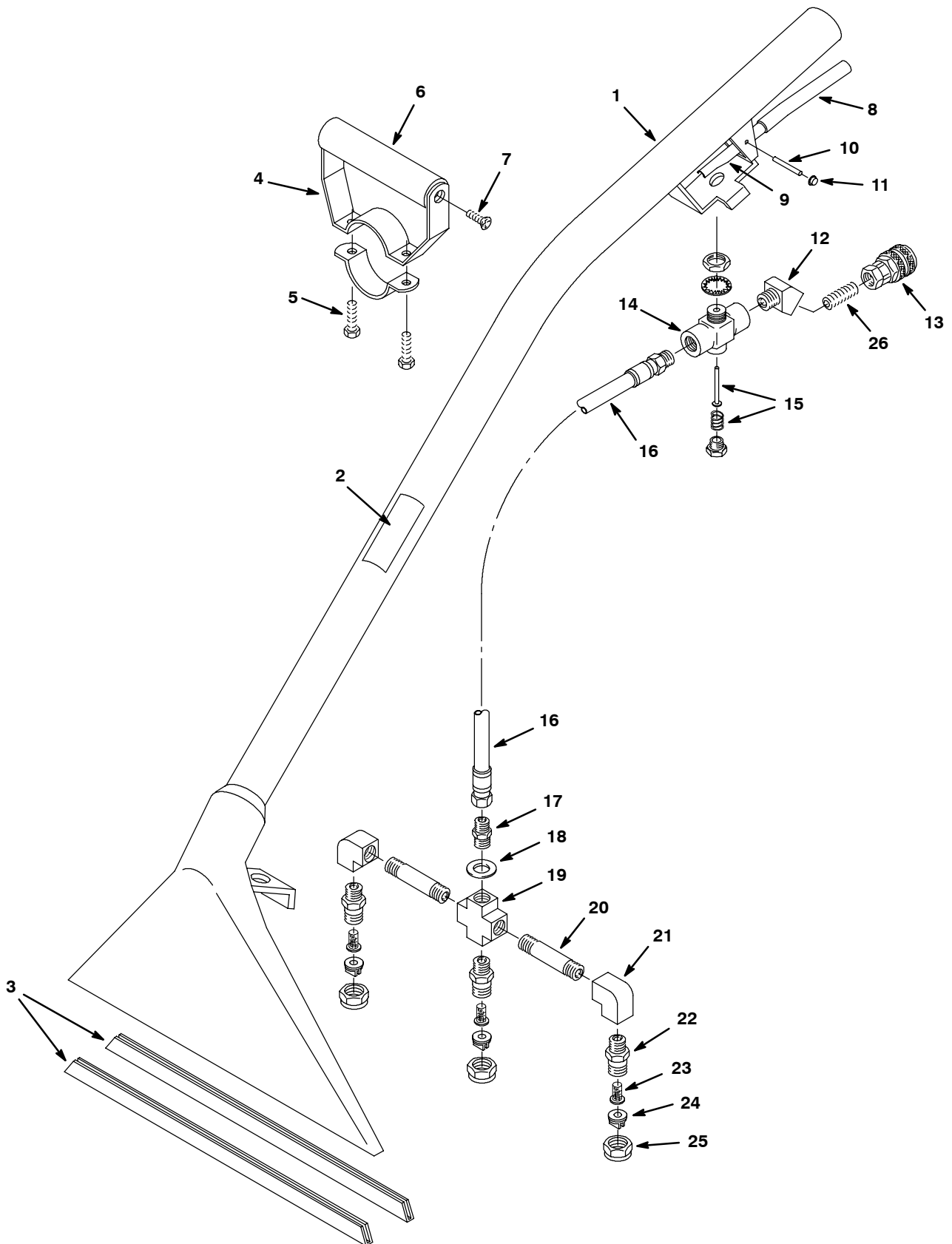

330mm (13 in) LOW PRESSURE WAND GROUP

REF	PART #	DESCRIPTION	QTY.
▽	600048	●ASM., FLOOR TOOL 330MM (13 IN)	1
▲ 1	200403.BK	TOOL, FLOOR BLACK	1
▲ 2	120846	DECAL, LOW PRESSURE TOOL	1
▲ 3	200939	●SHOE, 330MM (13 IN) FLR TOOL	2
▲▽ 4	200927	GRIP, HAND ADJ. COMPLETE	1
▲ 5	140259	SCREW, 1/4-20X5/8 HXHD	2
▲ 6	200912	GRIP, HANDLE FOAM	1
▲ 7	140834	SCREW, 1/4-20X5/8 FLTPHL	2
▲ 8	200809	SLEEVE, HANDLE	1
▲ 9	200902	HANDLE, VALVE	1
▲ 10	140605	PIN, HANDLE	1
▲ 11	140520	NUT, 1/4 PUSH BLK	2
▲ 12	150403	FITTING, E45 04PM/04PF	1
▲ 13	150913	●FITTING, QDC PF04 SER. 60	1

REF	PART #	DESCRIPTION	QTY.
▲▽ 14	210150	●VALVE, FLOW CONTROL	1
▲ 15	190603	●KIT, VALVE PIN AND SPRING	1
▲ 16	160170	WAND HOSE ASSEMBLY, 46"	1
▲ 17	150606	FITTING, 1/4MX1-3/8HEXNIP	1
▲ 18	140058	WASHER, .543X.875X.062 WAND	1
▲▽	700062	ASM., SPRAYBAR 12" WO/TIPS	1
▲ 19	150700	CROSS, 1/4 FPTXFPTXFPTXFPT	1
▲ 20	150600	FITTING, 1/4MX2" NIPPLE	2
▲ 21	150401	FITTING, E90 04PF/04PF	2
▲ 22	200993	SPRAY BODY, 1/4" MALE	3
▲ 23	200996	●FILTER, SCREEN 100-MESH	3
▲ 24	200964	●FITTING, TIP 11003 T-JET	3
▲ 25	200994	●CAP, NOZZLE, SPRAY #8002	3
▲ 26	150615	FITTING, 04PM CLOSE	1

▽ ASSEMBLY

▲ INCLUDED IN ASSEMBLY

● RECOMMENDED STOCK ITEMS

406mm (16 in) LOW PRESSURE WAND GROUP

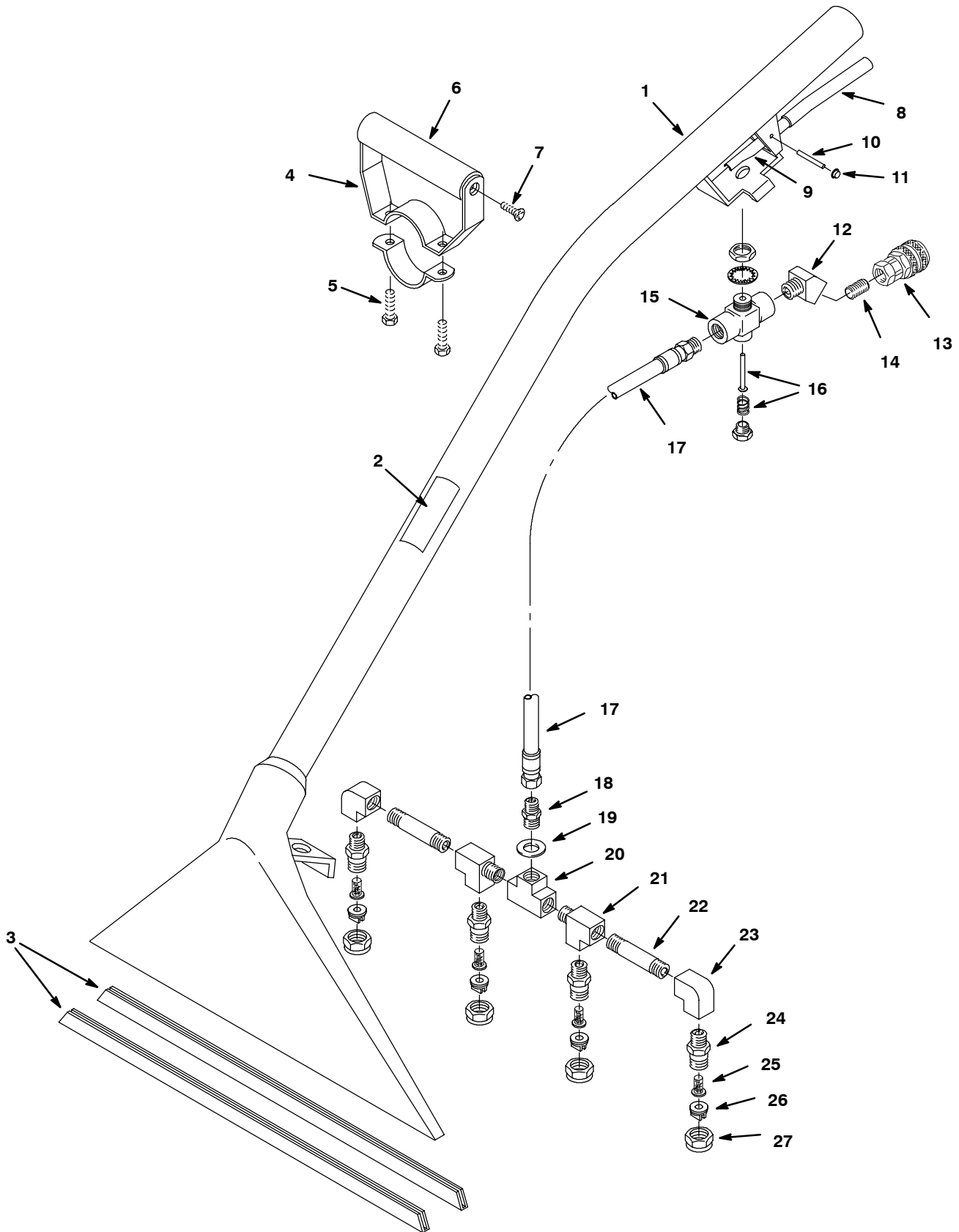

406mm (16 in) LOW PRESSURE WAND GROUP

REF	PART #	DESCRIPTION	QTY.
▽	200503	●ASM., FLOOR TOOL 406MM (16 IN)	1
▲ 1	200411.BK	TOOL, FLOOR	1
▲ 2	120846	DECAL, LOW PRESSURE TOOL	1
▲ 3	200956	●SHOE, 406MM (16 IN) FLR TOOL	2
▲▽ 4	200927	GRIP, HAND ADJ. COMPLETE	1
▲ 5	140259	SCREW, 1/4-20X5/8 HXHD	2
▲ 6	200912	GRIP, HANDLE FOAM	1
▲ 7	140834	SCREW, 1/4-20X5/8 FLTPHL	2
▲ 8	200809	SLEEVE, HANDLE	1
▲ 9	200902	HANDLE, VALVE	1
▲ 10	140605	PIN, HANDLE	1
▲ 11	140520	NUT, 1/4 PUSH BLK	2
▲ 12	150403	FITTING, E45 04PM/049F	1
▲ 13	150913	●FITTING, QDC PF04 SER. 60	1
▲ 14	150615	FITTING, 04PM CLOSE	1

REF	PART #	DESCRIPTION	QTY.
▲▽ 15	210150	●VALVE, FLOW CONTROL	1
▲ 16	190603	●KIT, VALVE PIN AND SPRING	1
▲ 17	160170	WAND HOSE ASSEMBLY, 46 IN.	1
▲ 18	150606	FITTING, 1/4MX1-3/8HEXNIP	1
▲ 19	140058	WASHER, .543X.875X.062 WAND	1
▲▽	700656	ASM., SPRAYBAR 16" WO/TIPS	1
▲ 20	150706	FITTING, 1/4F TEE	1
▲ 21	150709	FITTING, TEE 04PM/04PF/04PF	2
▲ 22	150600	FITTING, 1/4MX2" NIPPLE	2
▲ 23	150401	FITTING, E90 PFO4/PF04	2
▲ 24	200993	SPRAY BODY, 1/4" MALE	4
▲ 25	200996	●FILTER, SCREEN 100-MESH	4
▲ 26	200964	●FITTING, TIP 11003 T-JET	4
▲ 27	200994	●CAP, NOZZLE, SPRAY #8002	4

▽ ASSEMBLY

▲ INCLUDED IN ASSEMBLY

● RECOMMENDED STOCK ITEMS

OPTIONS

UPHOLSTERY TOOL GROUP

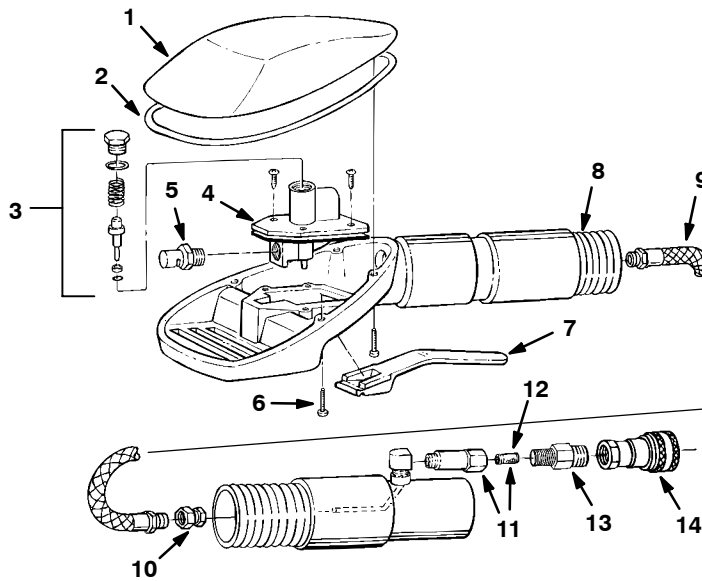

REF	PART #	DESCRIPTION	QTY.
▽	200540	●ASM., TOOL UPHOLSTERY SER 60	1
▲ 1	200845	COVER, UPHOLSTERY TOOL	1
▲ 2	200843	●GASKET, COVER	1
▲ 3	190631	●KIT, SERVICE LP (VALVE ASM.)	1
▲ 4	210226	●VALVE, WATER/SOL. LP	1
▲ 5	200991	●FITTING, 1/8-K JET	1
▲ 6	200838	SCREW, 6-32 X .75	4
▲ 7	200840	TRIGGER, UPHOLSTERY TOOL	1

REF	PART #	DESCRIPTION	QTY.
▲ 8	200844	●HOSE, VACUUM W/O CUFFS	1
▲ 9	200837	●HOSE, SOLUTION	1
▲ 10	200848	FITTING, BRS (3 PCS)	1
▲ 11	200842	●FILTER, INLINE COMPLETE	1
▲ 12	200841	●SCREEN ONLY, INLINE FILTER	1
▲ 13	150606	FITTING, BRS STR PM04X1.38HXNIP	1
▲ 14	150913	●FITTING, BRS QDC PF04 SER 60	1

CHEMICALS

REF	PART #	DESCRIPTION	QTY.
N/S	874891	●CHEMICAL, SPOT AND STAIN REMOVER, 12 - 16OZ BOTTLES	1
N/S	874917	●PET STAIN/ODER ELIMINATOR, 12 - 16OZ BOTTLES	1
N/S	874925	●TRAFFIC LANE CLEANER, 12 - 32OZ SPRAY BOTTLES	1
N/S	874941	●DEODERIZER, 12 - 16OZ BOTTLES	1
N/S	875013	●ALL IN ONE CLEANER, 32OZ 12 BOTTLES PER CASE	1
N/S	874966	●ALL IN ONE CLEANER, 1/2GAL 6 BOTTLES PER CASE	1
N/S	874958	●ALL IN ONE CLEANER, 1GAL 4 BOTTLES PER CASE	1

REF	PART #	DESCRIPTION	QTY.
N/S	875104	●REGULAR CARPET CLEANER 32OZ, 12 BOTTLES PER CASE	1
N/S	875047	●REGULAR CARPET CLEANER 1/2GAL, 6 BOTTLES PER CASE	1
N/S	875021	●REGULAR CARPET CLEANER 1 GAL, 4 BOTTLES PER CASE	1
N/S	875112	●DEFOAMER, 12 - 16OZ BOTTLES	1
N/S	875120	●UPHOLSTERY CLEANER, 12 - 32OZ BOTTLES	1

▽ ASSEMBLY

▲ INCLUDED IN ASSEMBLY

● RECOMMENDED STOCK ITEMS

N/S = NOT SHOWN

SOLUTION AND VACUUM HOSES GROUP

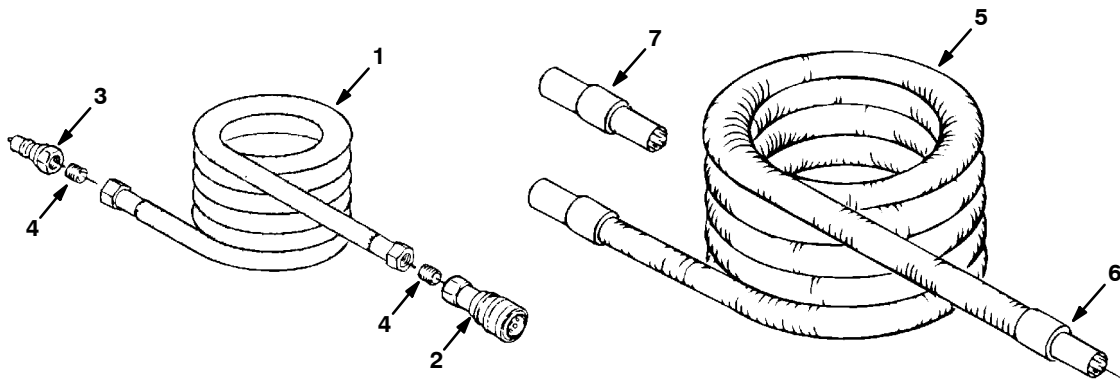

REF	PART #	DESCRIPTION	QTY.
▽ 1	160185	HOSE, SOLUTION 4.6M / 15' (STANDARD)	1
	610792	HOSE, SOLUTION 7.6M / 25' (OPTIONAL)	1
	160192	HOSE, SOLUTION 15.2M / 50' (OPTIONAL)	1
▲ 2	150913	●COUPLER, QUICK SER. 60	1
▲ 3	150933	PLUG, QUICK COUPLER	1
▲ 4	150615	NIPPLE	2

REF	PART #	DESCRIPTION	QTY.
▽ 5	160400	HOSE, VACUUM 4.6M / 15' (STANDARD)	1
	160401	HOSE, VACUUM 7.6M / 25' (OPTIONAL)	1
	160402	HOSE, VACUUM 15.2M / 50' (OPTIONAL)	1
▲ 6	160430	●CUFF, HOSE 1-1/2"	2
7	160451	●CONNECTOR, 1-1/2" VAC HOSE	1
N/S	220040	●BAG, HOSE W/DRAW STRING (OPTIONAL)	1

▽ ASSEMBLY

▲ INCLUDED IN ASSEMBLY

● RECOMMENDED STOCK ITEMS

N/S = NOT SHOWN