

# Castex®

## PX-1100LP

Carpet And Upholstery Cleaner

**Model No.:**  
**610697 – 11 gal LP Can.**  
**Extractor**

**Operator and Parts Manual**

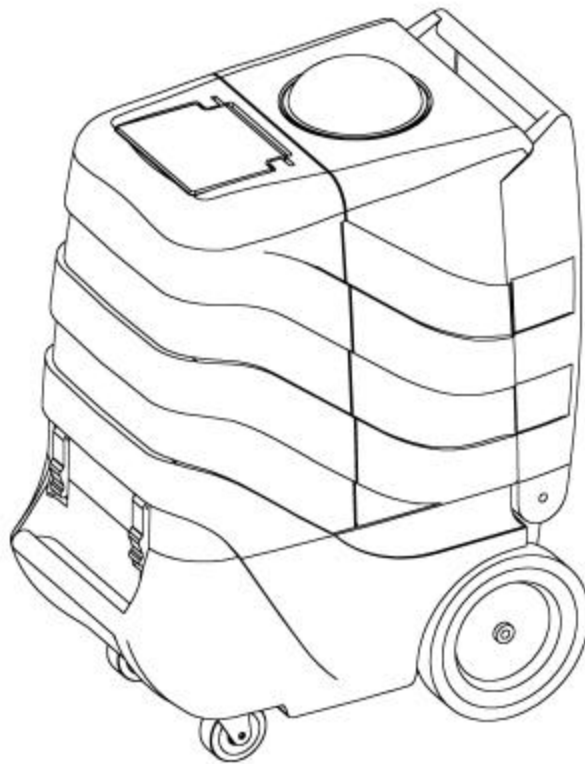

**CASTEX**  
12875 RANSOM STREET  
HOLLAND MI 49424 U.S.A.

**FAX: 1-800-678-4240**  
**CUSTOMER SERVICE: 1-800-964-9644**

**610201**  
**Rev. 01 (07-00)**

# OPERATION

---

This manual is furnished with each new model. It provides necessary operation and maintenance instructions and an illustrated parts list.

**Read this manual completely and understand the machine before operating or servicing it.**

Use the illustrated Parts Lists to order parts. Before ordering parts or supplies, be sure to have your machine model number and serial number handy. Parts and supplies may be ordered by phone or mail from any authorized parts and service center, distributor or from any of the manufacturer's subsidiaries.

This machine will provide excellent service. However, the best results will be obtained at minimum costs if:

- The machine is operated with reasonable care.
- The machine is maintained regularly – per the maintenance instructions provided.
- The machine is maintained with manufacturer supplied or equivalent parts.

---

## MACHINE DATA

---

Please fill out at time of installation for future reference.

Model No.- \_\_\_\_\_

Install. Date- \_\_\_\_\_

Serial No.- \_\_\_\_\_

© 2000 Tennant Company Printed in U.S.A.

Castex is a registered United States trademark of Tennant Company

---

## TABLE OF CONTENTS

---

<b>SAFETY PRECAUTIONS .....</b>	<b>3</b>
<b>SAFETY LABELS .....</b>	<b>4</b>
<b>MACHINE COMPONENTS.....</b>	<b>5</b>
<b>MACHINE SETUP .....</b>	<b>5</b>
<b>MACHINE OPERATION.....</b>	<b>6</b>
<b>DRAINING TANKS .....</b>	<b>7</b>
<b>FREEZE PROTECTION.....</b>	<b>7</b>
<b>MACHINE MAINTENANCE.....</b>	<b>8</b>
<b>STORING MACHINE .....</b>	<b>8</b>
<b>RECOMMENDED STOCK ITEMS .....</b>	<b>8</b>
<b>TROUBLE SHOOTING .....</b>	<b>9</b>
<b>SPECIFICATIONS .....</b>	<b>10</b>
<b>ELECTRICAL DIAGRAM .....</b>	<b>11</b>
<b>PARTS LIST .....</b>	<b>12</b>
<b>OPTIONS .....</b>	<b>17</b>

# OPERATION

---

## SAFETY PRECAUTIONS

---

This machine is intended for commercial use. It is designed to clean carpet and upholstery in a indoor environment and is not constructed for any other use. Use only recommended cleaning solutions and accessory tools.

All operators must read, understand and practice the following safety precautions.

The following safety alert symbols are used throughout this manual as indicated in their description:

**⚠ WARNING: To warn of hazards or unsafe practices which could result in severe personal injury or death.**

**FOR SAFETY: To identify actions which must be followed for safe operation of equipment.**

The following information signals potentially dangerous conditions to the operator or equipment.

### FOR SAFETY:

1. **Do not operate machine:**
  - Unless trained and authorized.
  - Unless operator manual is read and understood.
  - In flammable or explosive areas.
  - With damaged cord or plug.
  - If not in proper operating condition.
  - Unless cord is properly grounded.
  - In outdoor areas.
  - In standing water.
  - With the used of an extension cord.
2. **Before operating machine:**
  - Make sure all safety devices are in place and operate properly.
3. **When using machine:**
  - Do not run machine over cord.
  - Do not pull machine by plug or cord.
  - Do not pull cord around sharp edges or corners.
  - Do not unplug by pulling on cord.
  - Do not stretch cord.
  - Do not handle plugs with wet hands.
  - Keep cord away from heated surfaces.
  - Report machine damage or faulty operation immediately.
  - Following mixing and handling instructions on chemical containers.

4. **Before leaving or servicing machine:**
  - Turn off machine.
  - Unplug cord from wall outlet.
5. **When servicing machine:**
  - Unplug cord from wall outlet.
  - Avoid moving parts. Do not wear loose jackets, shirts, or sleeves.
  - Use manufacturer supplied or approved replacement parts.

**⚠ WARNING: Hazardous Voltage. Shock or electrocution can result. Always unplug machine before servicing.**

**⚠ WARNING: Flammable materials can cause an explosion or fire. Do not use flammable materials in tank(s).**

**⚠ WARNING: Flammable materials or reactive metals can cause an explosion or fire. Do not pick up.**

---

## GROUNDING INSTRUCTIONS

Machine must be grounded. If it should malfunction or breakdown, grounding provides a path of least resistance for electrical current to reduce the risk of electrical shock. This machine is equipped with a cord having an equipment-grounding connector and grounding plug. The plug must be plugged into an appropriate outlet that is properly installed in accordance with all local codes and ordinances. Do not remove ground pin; if missing, replace plug before use.

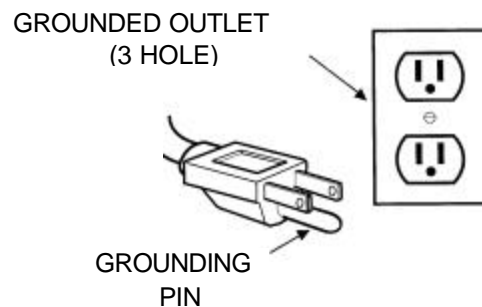

# OPERATION

## SAFETY LABELS

The safety labels appear on the machine in the locations indicated. Replace labels if they become damaged or illegible.



**FOR SAFETY LABEL-**  
Located on rear panel.

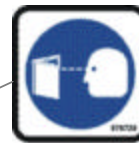

**FOR SAFETY:**  
**Read manual**  
**before operating**  
**machine.**



**FLAMMABLE MATERIALS/  
SPILLS LABEL-** Located on  
rear panel.

**WARNING:** Flammable materials  
can cause explosion or fire. Do  
not use flammable materials in  
tank(s). Flammable materials or  
reactive metals can cause  
explosion or fire. Do not pick up.



**HAZARDOUS VOLTAGE  
LABEL-** Located on rear  
panel.

**WARNING:** Hazardous Voltage.  
Shock or electrocution can  
result. Always unplug machine  
before servicing.

# OPERATION

## MACHINE COMPONENTS



1. Recovery Tank
2. Solution Tank
3. Recovery Tank Lid
4. Solution Tank Lid
5. Vacuum Switch
6. Pump Switch
7. Power Cord Connect

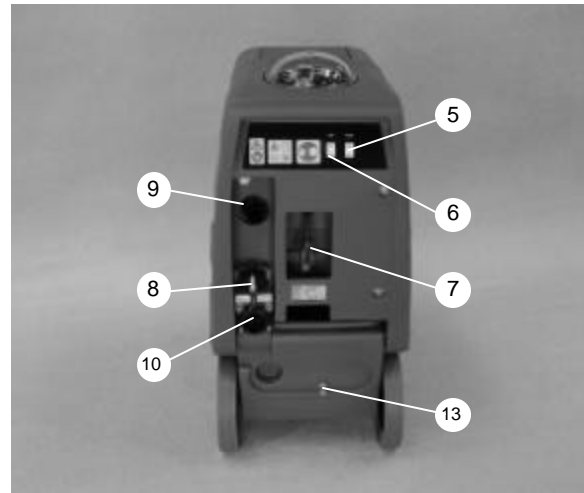

8. Empty-Out Nozzle
9. Vacuum Hose Connector
10. Recovery Tank Drain
11. Latches
12. Push/Pull Handle
13. Solution Hose Connector
14. 254 mm (10") Wheels, non-marking

## MACHINE SETUP

1. Carefully check carton for signs of damage. Report damages at once to carrier. The machine is shipped fully assembled and is ready for use.
2. Connect hoses and tool to be used (Figure 1).



Fig. 1

3. Using a clean bucket or hose, fill solution tank with 41 liters (11 gallons) of hot water, 60° C (140° F) maximum (Figure 2).

**⚠ WARNING: Flammable materials can cause an explosion or fire. Do not use flammable materials in tank(s).**

4. Add a recommended cleaning chemical.

**FOR SAFETY: When using machine, follow mixing and handling instructions on chemical containers.**



Fig. 2

# OPERATION

---

**ATTENTION:** If using powdered cleaning chemicals, mix prior to adding.

**NOTE:** If desired, water alone achieves excellent cleaning results.

5. Plug machine's power cord into a grounded wall outlet (Figure 3).

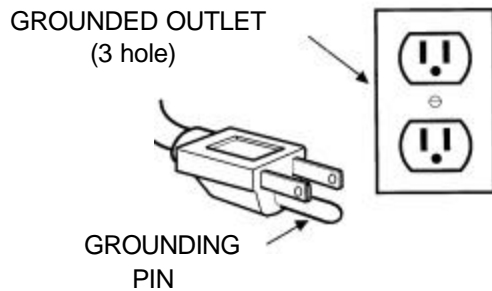

Fig. 3

**FOR SAFETY:** Do not operate machine unless cord is properly grounded.

**FOR SAFETY:** Do not operate machine with the use of an extension cord.

6. Secure recovery tank lid in place.

---

## MACHINE OPERATION

---

**FOR SAFETY:** Do not operate machine unless operator manual is read and understood.

---

### PRE-OPERATION

1. Vacuum carpet and remove other debris.
2. Inspect power cord for damage.

---

### CLEANING CARPETS

1. Activate vacuum and pump switches (Figure 4).



Fig. 4

2. Take carpet cleaning wand in hand and squeeze valve trigger while moving the tool in short forward and backward strokes over the carpet (Figure 5).

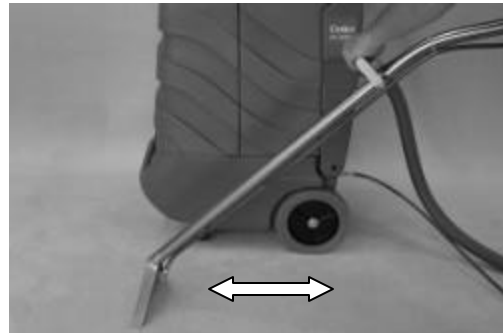

Fig. 5

---

### WHILE OPERATING

1. Overlap each path by 50 mm (2 in).

**⚠ Warning:** Flammable materials or reactive metals can cause an explosion or fire. Do not pick up.

2. Periodically check for excessive foam buildup in recovery tank. Use a recommended foam control solution to prevent vacuum motor damage.

**ATTENTION:** Excessive foam buildup will not activate the float shut-off screen.

3. To clean heavily soiled areas, repeat cleaning path from a different direction.
4. Empty recovery tank every time water is added to solution tank.

---

### CLEANING WITH ACCESSORY TOOLS

1. Connect accessory tool hoses to the couplers at the end of the hoses already attached to the machine (Figure 6).



Fig. 6

## OPERATION

---

2. Operate accessory tool as normal (Figure 7).

**NOTE:** Before cleaning upholstery, always check cleaning instructions sewn in furniture by manufacturer.



FIG. 7

3. After cleaning, relieve water pressure from tool before disconnecting hose. Squeeze trigger for five seconds after turning switches off.

---

## DRAINING TANKS

---

---

### DRAINING RECOVERY TANK

1. Turn machine off and unplug power cord.
2. Insert supplied 45° elbow in drain valve. Place a bucket below it and slowly pull up on the handle (Figure 8).

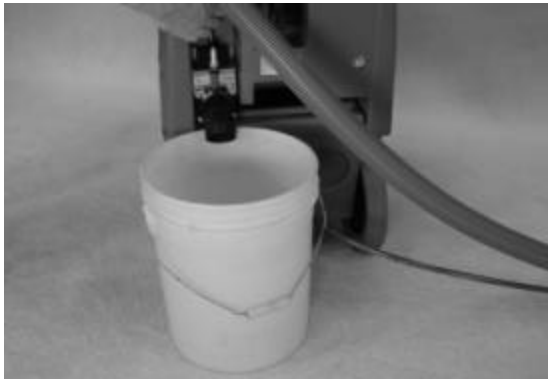

FIG. 8

3. Rinse tank with clean water at the end of the day.

---

### DRAINING SOLUTION TANK

1. Remove empty-out nozzle from its storage bracket (Figure 9) and attach to end of solution hose.



FIG 9

2. Place empty-out nozzle over a bucket and turn on pump until all the solution has been pumped from solution tank.
3. Replace empty-out nozzle to its storage location.

---

### FREEZE PROTECTION

---

1. After draining solution tank as described in steps one and two in the previous section (DRAINING SOLUTION TANK), place empty-out nozzle in end of vacuum hose and seal with hand (Figure 10).



FIG. 10

2. Turn on vacuum and pump for 15 seconds. This will fill the pump and hoses with air and prevent freezing.
3. Replace empty-out nozzle to its storage place.

# OPERATION

## MACHINE MAINTENANCE

To keep machine in good working condition, simply follow machine's daily, weekly and monthly maintenance procedures.

**FOR SAFETY: When servicing machine, unplug cord from wall outlet.**

### DAILY MAINTENANCE (Every 4 Hours of Operation)

1. Empty and rinse out recovery tank thoroughly.
2. Remove float shut-off screen from recovery tank and clean (Figure 11).



FIG. 11

3. When solution tank is empty, remove and clean solution filter screen located in the bottom of the solution tank.
4. Wipe off power cord and check for damage, replace if necessary. Coil cord neatly after use.
5. Clean machine with an all purpose cleaner and damp cloth.

### WEEKLY MAINTENANCE (Every 20 Hours of Operation)

1. Inspect vacuum hoses for holes and loose cuffs.
2. Inspect spray pattern for plugging. If plugged, remove spray tips and soak them in acetic acid solution for up to six hours. Do not use pointed objects to unplug tips, damage will occur.

**FOR SAFETY: When using machine, follow mixing and handling instructions on chemical containers.**

3. Inspect cord and cord grip for damage. Replace immediately if damaged.
4. Lubricate metal shaft on recovery tank drain with water resistant oil.
5. Lubricate female hose couplers with lightweight oil.

### MONTHLY MAINTENANCE (Every 80 Hours of Operation)

1. Lubricate wheels with water resistant oil.
2. Inspect machine for water leaks and loose hardware.

### QUARTERLY MAINTENANCE (Every 250 hours of Operation)

Check vacuum motor for carbon brush wear. Replace brushes or motor if worn to a length of 10mm (0.38") or less.

## STORING MACHINE

1. Before storing machine, be certain to drain and rinse tanks of all water.
2. Store machine in a dry area in the upright position.
3. Unscrew recovery tank lid to promote air circulation.

**ATTENTION: Do not expose to rain. Store indoors.**

**ATTENTION: If storing machine in freezing temperatures, be sure that machine and solution system are completely drained and dry.**

## RECOMMENDED STOCK ITEMS

Refer to Parts List section for recommended stock items. Stock items are clearly identified with a bullet preceding the parts description. See example below:

REF	PART #	DESCRIPTION	QTY.
1	610470	NUT 1/4-20 NYLOK ZINK	3
2	610471	WASHER 1/4 FLAT CP	6
3	610579	● BLOWER 3STG 120V 5.7 COMP	1
4	610487	GASKET BLOWER/ARLON 1/4"	1

# OPERATION

---

## TROUBLE SHOOTING

PROBLEM	CAUSE	SOLUTION
Machine does not operate.	Faulty switches or wiring.	Contact Service Center.
	Faulty power cord.	Contact Service Center.
	Building circuit breaker tripped.	Reset Breaker.
Solution pump does not operate.	Faulty switch or wiring.	Contact Service Center.
	Faulty solution pump motor.	Contact Service Center.
	Faulty pump head.	Contact Service Center.
	Trigger on wand not pulled.	Pull Solution Trigger.
	Quick couplers not fully engaged.	Connect quick couplers.
Vacuum motor does not operate.	Loose or broken wiring.	Contact Service Center.
	Faulty vacuum switch.	Contact Service Center.
	Defective vacuum motor.	Contact Service Center.
	Worn carbon brushes.	Contact Service Center.
Poor solution pick-up.	Recovery tank drain valve open.	Close valve.
	Defective recovery tank lid gasket.	Replace gasket.
	Clogged float shut-off screen.	Remove recovery tank lid and clean screen.
	Loose vacuum hose connections.	Secure cuffs to hose.
	Defective vacuum hose.	Replace hose.
Uneven or no spray.	Plugged spray tips.	Clean or replace tips.
	Improper spray tip size or spray angle.	Replace with proper tips.
	Worn spray tips.	Replace spray tips.
	Solution tank low or empty.	Refill solution tank.
	Faulty solution pump.	Contact Service Center.

# OPERATION

## SPECIFICATIONS

<b>Model</b>	<b>PX-1100LP</b>
LENGTH	711 mm (28 in)
WIDTH	450 mm (17.7 in)
HEIGHT	959 mm (37.8 in)
WEIGHT	44.5 Kg (98lbs)
SOLUTION TANK CAPACITY	41 L (11 gal)
RECOVERY TANK CAPACITY	38L (10 gal)
SOLUTION PUMP	120 V, 6.8 bar (100psi), 1.0A
VACUUM MOTOR	120 V, 12.6A, 1512 W
SEALED WATER LIFT	3353 mm (132 in)
TOTAL POWER CONSUMPTION	120v, 13.6 A, 1632 W
POWER CORD	7.6m (25 ft) 3/12
DECIBEL RATING 3 METERS (10 FT) FROM MACHINE ON CARPET	<75 db(A)

## MACHINE DIMENSIONS

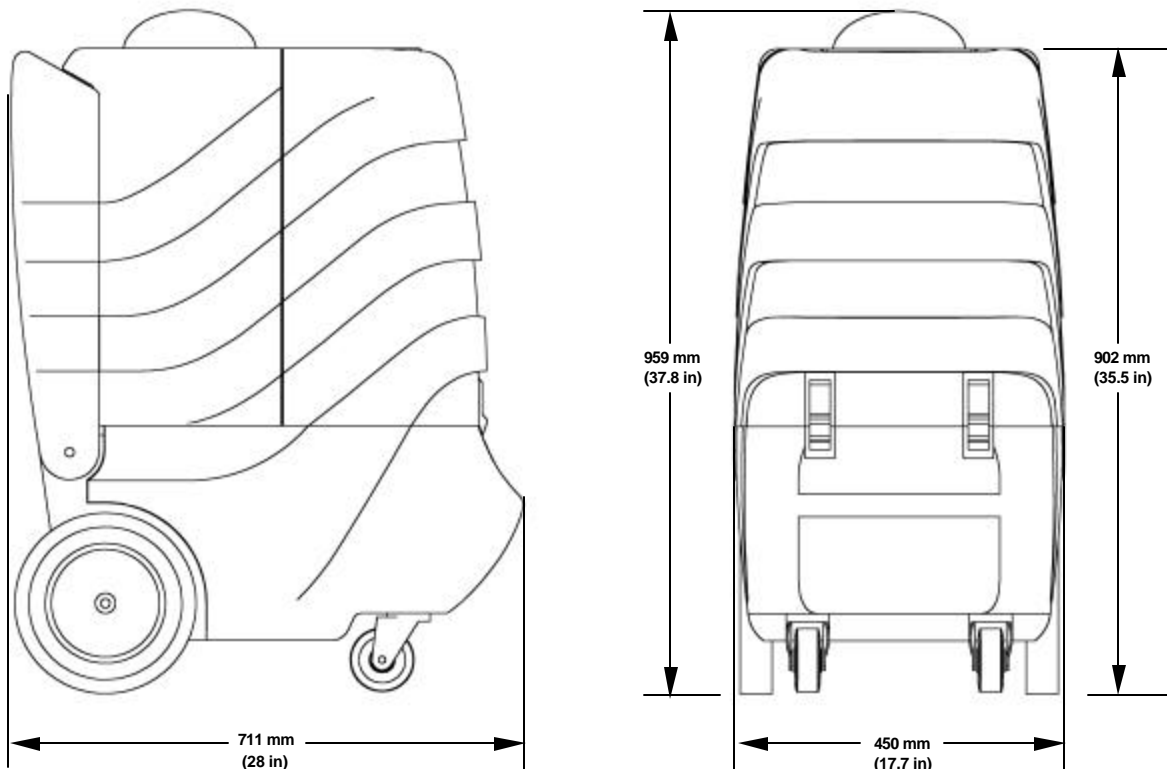

# ELECTRICAL DIAGRAM

## 120 V WIRING DIAGRAM

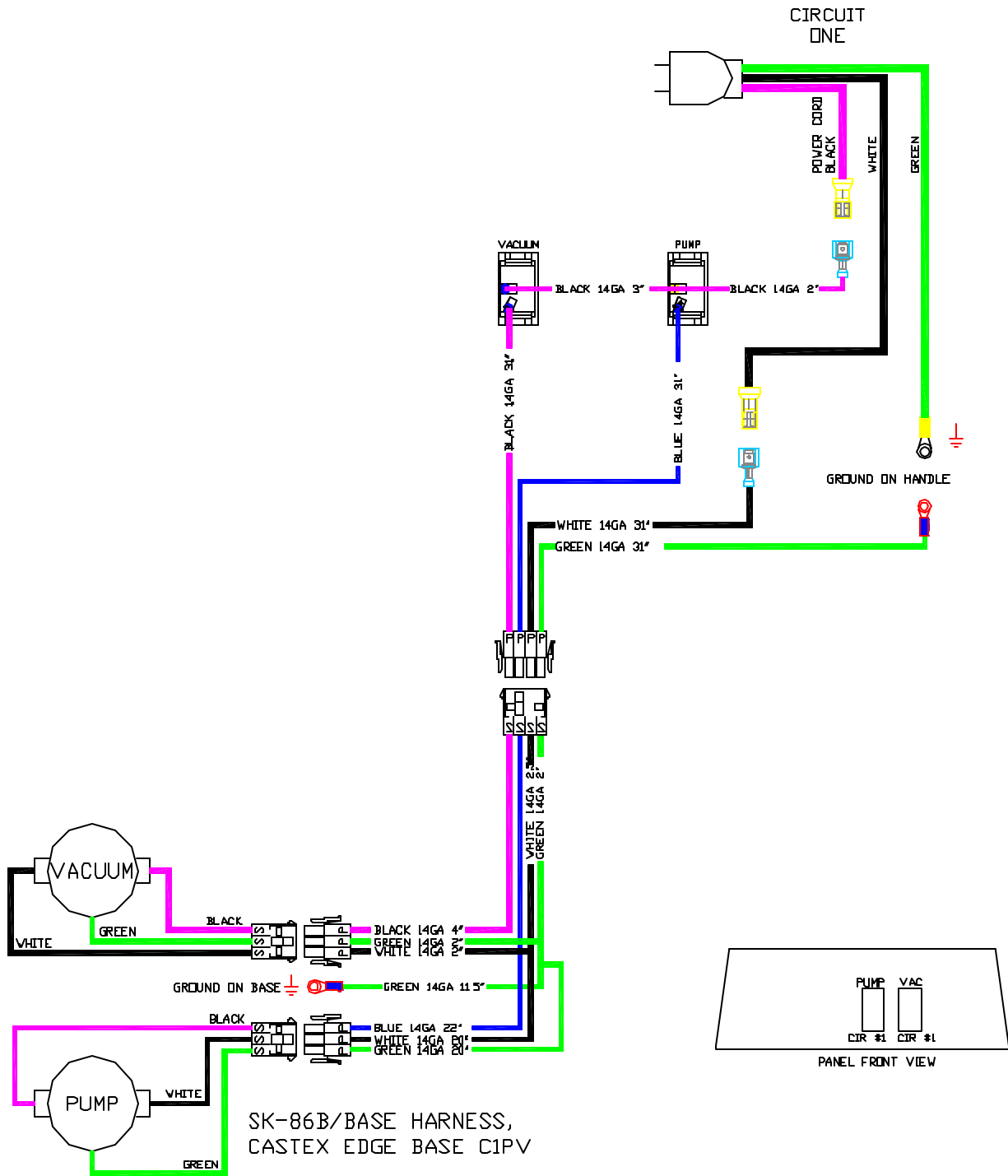



# PARTS LIST

## TANK GROUP

REF	PART #	DESCRIPTION	QTY.
1	610527	PNL EDGE PROF 100 BLANK	1
2	610538	NOZZEL EMPTY OUT MALE	1
3	610480	BUSHING HOLDER EMPTY-OUT	1
4	610462	10-32 X 1 1/2 PHXZINC	2
5	610475	3/8-16 X 4 HEX ZINC	1
6	610476	WASHER 3/8 FLAT ZINC	3
7	610474	3/8-16 X 3 1/2 HEX ZINC	1
8	610519	BRACKET SF-09 HOLDER EDGE	1
9	610539	• VALVE DUMP 1.5 W/PVC EXT	1
10	610576	HANDLE CASTEX EDGE2 2 SWIT	1
11	610183	DECAL CASTEX PX-1100LP	2
12	610463	NUT 10-32 HEX ZINC	2
13	610458	10-32 X 7/16 PHXSS	1
14	610522	PLATE HANDLE SW COVR EDGE	1
15	610457	10-32 X 5/16 PHXSS	6
16	610537	• HOSE 2" VINYL X 2.25"	1
17	610484	CLAMP HOSE 2 1/4 # 32	2
18	610473	3/8-16 X 1 1/2 HEX ZINC	2
19	610520	BRACKET DUMP VAL MNT EDGE	1
20	610491	PLUG HOLE NYLON .562	3
21	610515	• SWITCH SPST WATER RESIS	2
22	610460	10-32 X5/8 PHXSS	7
23	610482	CLAMP HOSE 1/4 #4	1
24	610563	TIE WIRE NYLON #10 SCREW	1
25	610512	NUT NYLON BUSHING REL 1/2	1
26	610511	BUSHING RELIEF 1/2 NPT	1
27	610578	• HARNESS EDGE HANDLE C1PV	1
28	610546	• CORD PIG TAIL EDGE COMP	1
29	610507	• LID DOME EDGE	1
30	610488	• GASKET DOME LID	1
31	610540	FLANGE ASM-DOME LID GLUE	1
32	610464	NUT 10-32 SS NYLOCK	6

REF	PART#	DESCRIPTION	QTY.
33	610483	CLAMP HOSE 2" # 24	1
34	610534	• HOSE VAC 1.5" FLEX 31"	1
35	610530	HOSE BARB ABS 1 1/2 CUT	1
36	610494	O-RING 1.76 X .187	2
37	610294	NECK, VAC FLTR EDGE 2 ROTO	1
38	610555	NUT 1/4-20 NYLOK SS	2
39	610556	WASHER 1/4 FLAT SS	4
40	610493	• FLOAT VAC SHUT OFF ROTO	1
41	610564	DEFLECTOR VAC INLET EDG2	1
42	610461	10-32 X 3/4 PHXSS	2
43	610558	HOSE BARB 1 1/2XMPT W/FLA	1
44	610296	ELBOW 90 ASSEMBLY EDGE 2	1
45	610575	VACUUM TANK EDGE 2 CASTEX	1
46	610557	CLAMP HOSE 1 3/4 #20	2
47	610566	HINDGE SOLUTION LID EDGE	1
48	610561	LID SOLUTION EDGE2 CASTEX	1
49	610486	• FILTER 1/4 NPT 50 MESH	1
50	610502	NIPPLE 1/4 NPT CLOSE BR	1
51	610568	BULK HEAD 1/4" BRASS W/O-RING	1
52	610506	O-RING VITON 2-020 BLKHD	1
53	610453	8-32 X 1/2 PHXSS	4
54	610490	LATCH SOFT DRAW BLACK	2
55	610478	WASHER 3/4 FLAT BLKHD CP	1
56	610479	NUT BULKHEAD 3/4-16 X .225	2
57	610500	ELBOW 90 1/4NPT-4 SAE	1
58	610574	SOLUTION TANK EDGE 2 CASTEX	1
59	610510	CORD 25' 12/3SJT UG W/LCK	1
60	578729	DECAL READ MANUAL	1
61	630420	DECAL FLAMMMABLE MAT'L	1
62	610185	DECAL HAZARD UNPLUG	1
63	610553	1/4-20 X 1 HEX HD SS	2

- RECOMMENDED STOCK ITEMS

BASE GROUP

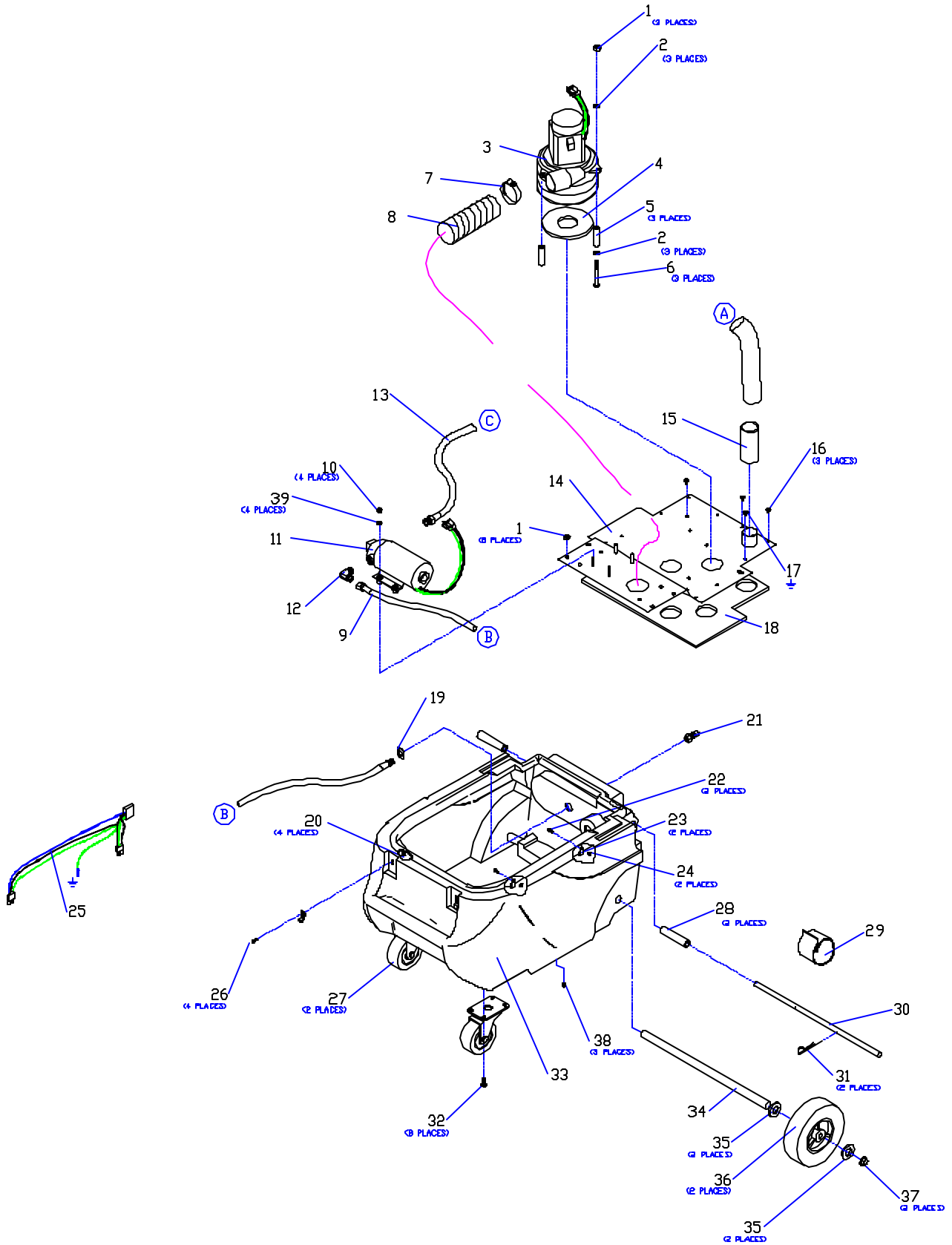

# PARTS LIST

## BASE GROUP

REF	PART #	DESCRIPTION	QTY.
1	610470	NUT 1/4-20 NYLOK ZINK	3
2	610471	WASHER 1/4 FLAT CP	6
3	610579	• BLOWER 3STG 120V 5.7 COMP	1
4	610487	• GASKET BLOWER/ARLON 1/4"	1
5	610567	STAND-OFF 5.7 EDGE 3.190	3
6	610554	1/4-20 X 4 1/2 HEX CP	3
7	610484	CLAMP HOSE 2 1/4 # 32	1
8	610535	• HOSE 2" FLEX EXHAUST 10"	1
9	610570	HOSE 1/4NPTX-6SAEVL 25" L	1
10	610465	NUT 10-32 NYLOK ZINC	4
11	610550	• PUMP SH FL 100PSI120V PLG	1
12	610501	ELBOW 90 3.8 NPT X-6 SAE	1
13	610571	HOSE 3/8NPT X-4SAEFMLSVL	1
14	610565	PLATE VAC MNT 1 VAC NO QUI	1
15	610504	CUFF 1 1/2SLIP X 1 1/4HO	1
16	610460	10-32 X 5/8 PHXSS	3
17	610457	10-32 X5/16 PHXSS	1
18	610489	GASKET VAC SEAL EDGE BASE	1
19	610526	SPACER QUICK CONNECT	1
20	610456	NUT 8-32 NYLOK, ZINC	4

REF	PART #	DESCRIPTION	QTY.
21	610505	Q/C 1/4" PLUG BR SHUT OFF	1
22	610451	6-32 X 1/2 PHXSS	2
23	610514	CLAMP NYLON CABLE 1/4"	2
24	610452	NUT 6-32 HEX SS	2
25	610577	• HARNESS BASE EDGE C1PV	1
26	610454	8-32 X 3/4 PHX ZINC	4
27	610481	• CASTER 3 1/2	2
28	610521	PIVOT TUBE EDGE 3.400"	2
29	610293	VELCRO ONE WRAP STRAP 1/2 X12	1
30	610517	AXIL ROD 1/2 EDGE ECONO	1
31	610485	COTTER HAIRPIN 7/16-9/16	2
32	610466	1/4-20 X 3/4 HEX HD CP	8
33	610572	BASE,CASTEX DRILLED, 1 VAC	1
34	610518	AXIL ROD 1/2 EDGE	1
35	610477	WASHER 9/16 X 1 1/4 FLAT	4
36	610492	• WHEEL 10"- 1/2BORE	2
37	610495	PUSHNUT FASTNER 1/2 CAP	2
38	610463	NUT 10-32 HEX ZINC	3
39	610295	WASHER .219 X .625 18 GA	4

- RECOMMENDED STOCK ITEMS

# PARTS LIST

## PUMP 100 PSI BREAKDOWN

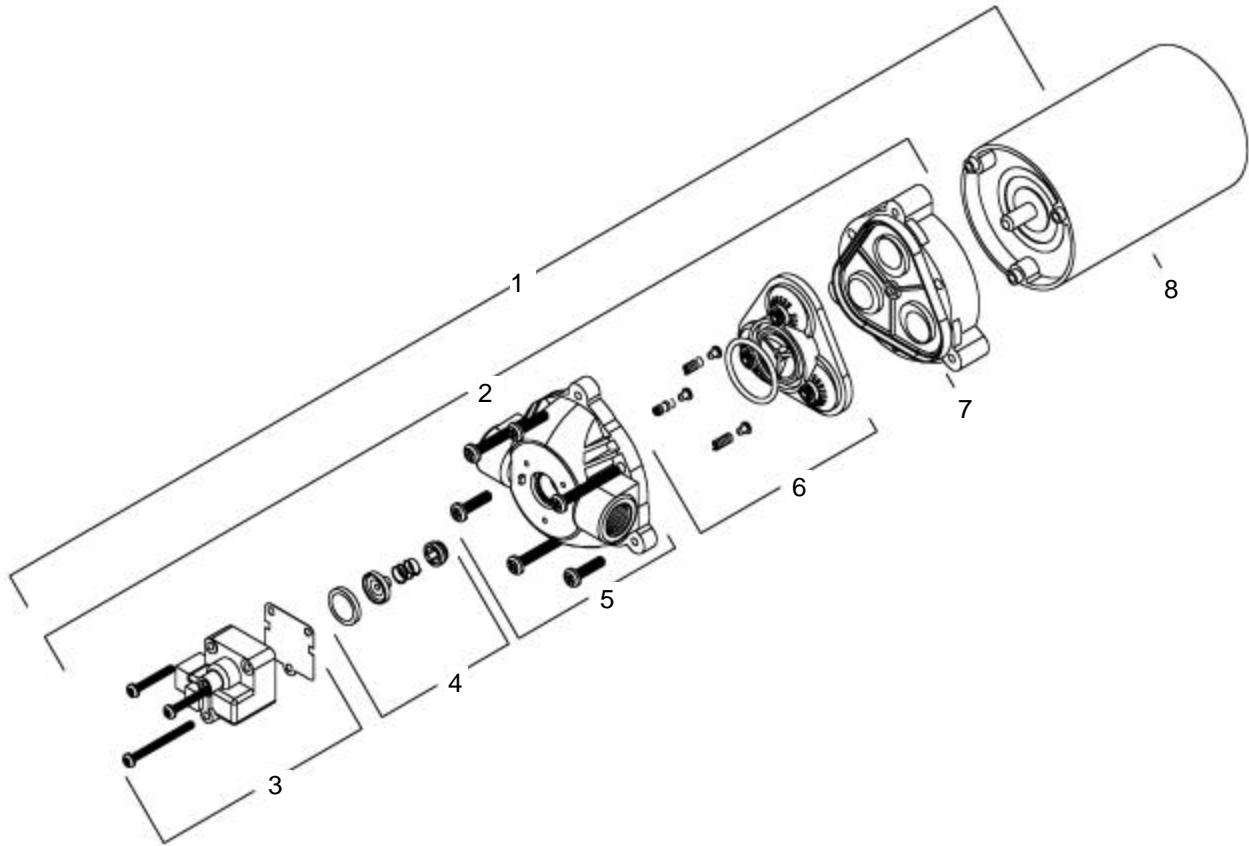

REF#	PART #	DESCRIPTION	QTY.
1	610550	● PUMP SH FL 100 PSI 120V PLG	1
2	610767	PUMP HEAD 100 PSI COMP ASM	1
3	610768	● SWITCH ASM, 100 PSI SH FL	1
4	610769	● CHECK VALVE ASM, 100 PSI SH FL	1
5	610770	HEAD, PUMP DIAPHRAGM	1
6	610771	● VALVE ASM, BYPASS SH FL	1
7	610772	DIAPHRAGM, SOLID DRIVE ASM	1
8	610773	MOTOR, 100 PSI 120V SH FL PLG	1

- RECOMMENDED STOCK ITEMS

# OPTIONS

## FLOOR TOOL

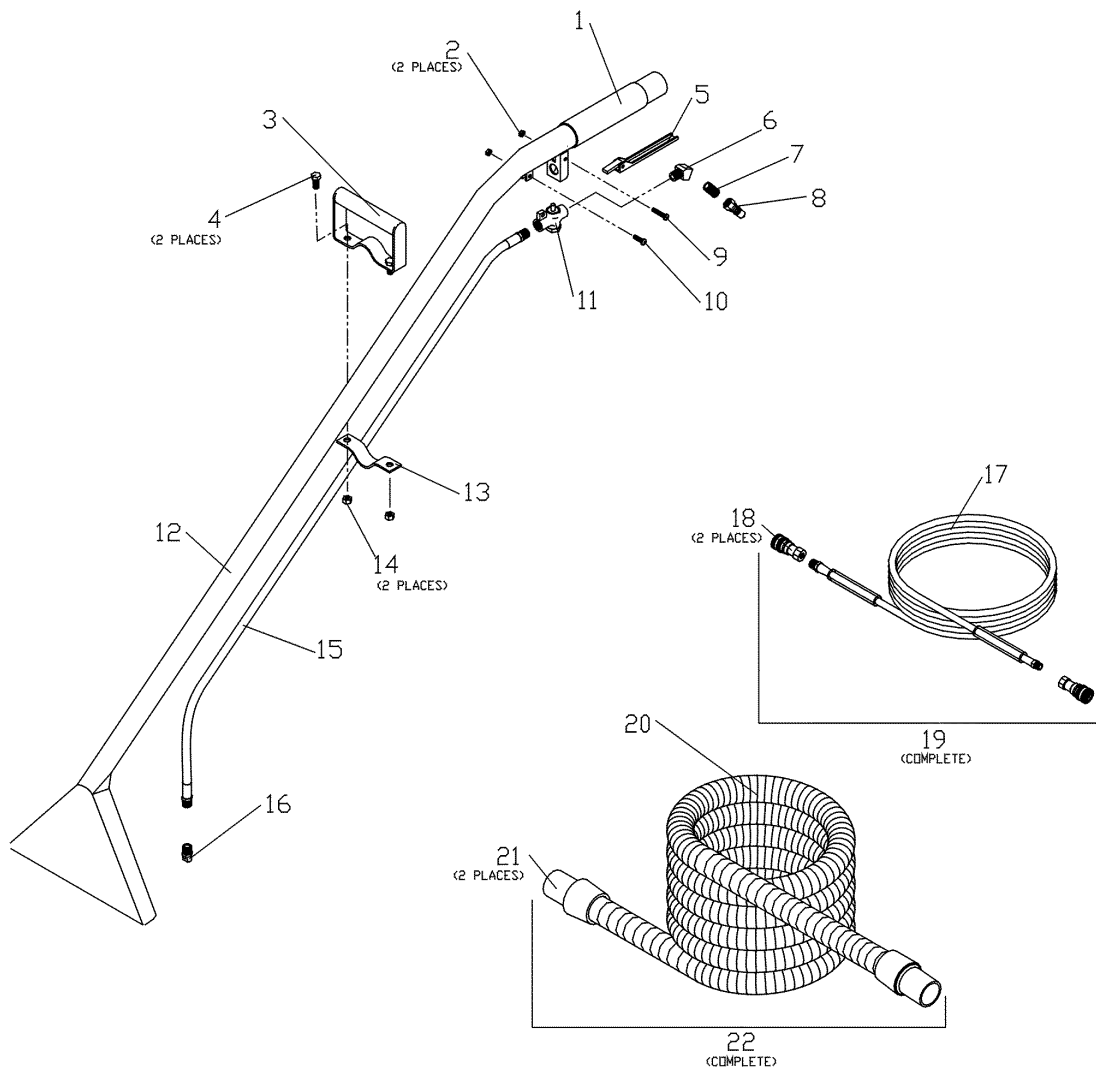

REF#	PART #	DESCRIPTION	QTY.
	610642	WAND & HOSE KIT LP-PX	1
	610710	WAND, FLOOR TOOL LP-PX COMP.	1
1	610624	GRIP, FLRTOOL 1 1/2 X 6	1
2	610465	NUT, 10-32 NYLOK ZINK	2
3	610628	HOE HANDLE, ECONO FLRTL	1
4	610622	5/16-18 X 3/4 HEX CP	2
5	610631	TRIGGER, COMP KNGSTN VALVE	1
6	610625	45 ST ELBOW 1/4 NPT	1
7	610502	NIPPLE, 1/4 NPT CLOSE BR	1
8	610505	Q/C 1/4" PLUG BR SHUT OFF	1
9	610621	10-32 X 1 3/8 PHX ZINC	1
10	610620	10-32 X 3/4 PHXZINC	1

REF#	PART #	DESCRIPTION	QTY.
11	610626	VALVE, KNGSTN STD S BND	1
12	610630	WAND, FLOOR TOOL	1
13	610629	"U"CLAMP, SUPP HOE HNDL EC	1
14	610623	NUT 5/16-18 NYLOCK, ZINC	2
15	610632	HOSE, 1/4 SOL 47" FLRTL ECO	1
16	610627	JET, 11006 E VEE BRASS	1
17	610637	HOSE, 1/4 SOL 25' NPT NO/QC	1
18	610638	Q/C 1/4" SOC BR SHUT OFF	2
19	610636	HOSE, 1/4 SOL 25' W/QC EDGE	1
20	610634	HOSE, VAC 1 1/2 GREY 25'	1
21	610633	CUFF, 1 1/2 SLIP 1 1/2 HOSE	2
22	610635	HOSE, VAC 1 1/2 X 25' W/1.5 CUFF	1

● RECOMMENDED STOCK ITEMS

# OPTIONS

## HAND TOOL

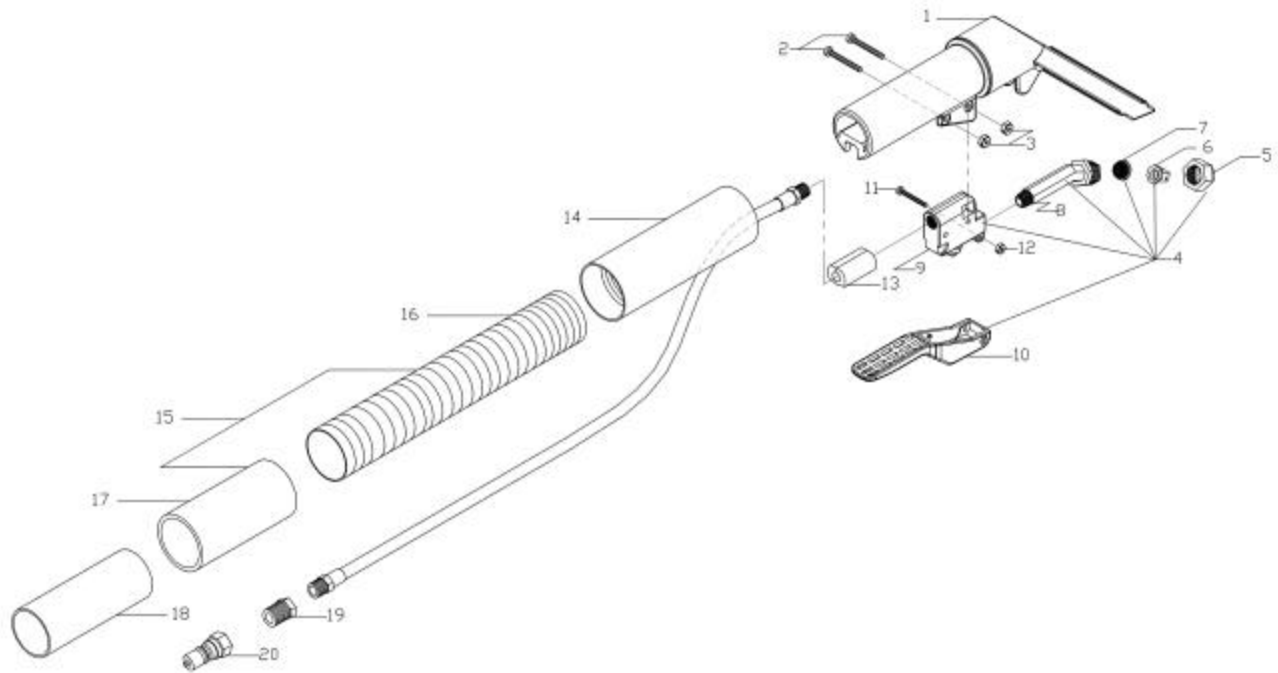

REF	PART #	DESCRIPTION	QTY.
	610298	TOOL, UPHOLSTERY LP-PX	
1	610668	TOOL, HAND LP BRASS JET W/VLV & TRIG	1
1	608891	TOOL, HAND W/O TRIGGER	1
2	610654	6-32 X 1 PHXZINC	2
3	610655	NUT, 6-32 HEX ZINC NYLOK	2
4	610665	VALVE & TRIGGER ASM. COMP LP	1
5	608897	CAP, SPRAY TIP HAND TOOL	1
6	610666	JET, 110015 E TEE BRASS	1
7	608900	SCREEN, HAND TOOL	1
8	608895	NOZZLE, SPRAY HAND TOOL	1
9	608894	BODY, VALVE HAND TOOL	1

REF	PART #	DESCRIPTION	QTY.
10	608898	TRIGGER, HAND TOOL	1
11	610658	4-40 X 7/8 PHXZINC	1
12	610659	NUT, 4-40 HEX ZINC NYLOK	1
13	608892	SEAL, SOLUTION HOSE	1
14	610667	HOSE TYGON 16.5" ASM W/ EXTRN CUFF	1
15	610661	ASM, 1 1/4" VAC GREY 12" W/ 1 1/4 CUFF	1
16	610662	HOSE, 1 1/4" VAC GREY LOOP 12"LONG	1
17	610669	CUFF, HOSE 1.5 X 1.25 GREY	1
18	610663	COUPLER, 1.5" VAC HOSE ALUM	1
19	610664	BUSHING 1/4 X 1/8 NPT BR	1
20	610505	Q/C 1/4" PLUG BR SHUT OFF	1