

# Castex®

## PX-1500HP

Carpet Extractor

Model No.:  
608217

Operator and Parts Manual

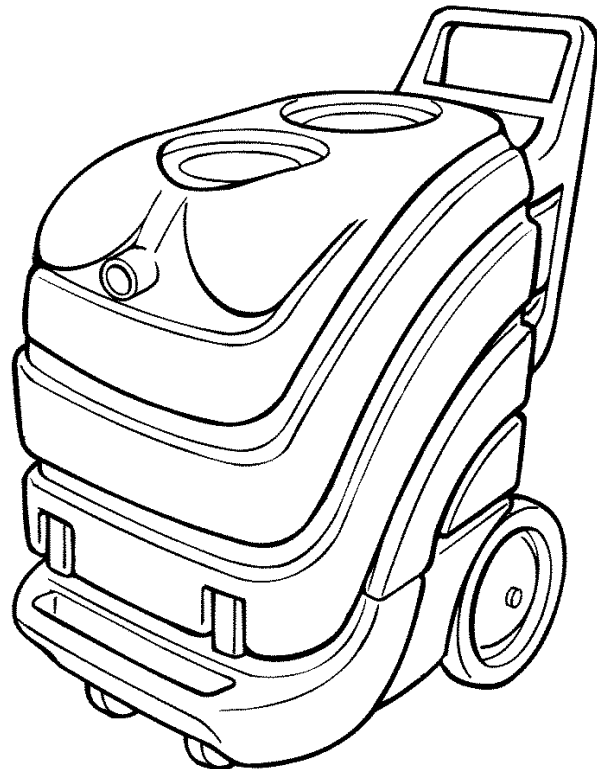

**CASTEX**  
12875 RANSOM STREET  
HOLLAND MI 49424 U.S.A.

FAX: 1-800-678-4240  
CUSTOMER SERVICE: 1-800-964-9644

608703  
Rev. 00 (06-99)

# OPERATION

---

This manual is furnished with each new model. It provides necessary operation, machine maintenance instructions and an illustrated parts list.

**Read this manual completely and understand the machine before operating or servicing it.**

Use the illustrated Parts Lists to order parts. Before ordering parts or supplies, be sure to have your machine model number and serial number handy. Parts and supplies may be ordered by phone or mail from any authorized parts and service center, distributor or from any of the manufacturer's subsidiaries.

This machine will provide excellent service. However, the best results will be obtained at minimum costs if:

- The machine is operated with reasonable care.
- The machine is maintained regularly - per the machine care instructions provided.
- The machine is maintained with manufacturer supplied or equivalent parts.

---

## MACHINE DATA

---

Please fill out at time of installation for future reference.

Model No.- \_\_\_\_\_

Install. Date - \_\_\_\_\_

Serial No.- \_\_\_\_\_

© 1999 Tennant Company

Printed in U.S.A.

---

## TABLE OF CONTENTS

---

SAFETY PRECAUTIONS .....	3
MACHINE SETUP .....	4
OPERATING FLOOR TOOL .....	5
OPERATING HAND TOOL .....	5
DRAINING MACHINE .....	6
MAINTENANCE .....	7
STORING MACHINE .....	8
TROUBLE SHOOTING .....	9
PARTS LIST .....	10
ELECTRICAL DIAGRAMS .....	15
OPTIONAL ACCESSORIES .....	16

---

## SAFETY PRECAUTIONS

---

This machine is suited to clean carpet and upholstery in an indoor environment and is not constructed for any other use. Use only recommended accessory tools and cleaning solutions.

The following safety alert symbols are used throughout this manual as indicated in their description.

**⚠ WARNING:** To warn of hazards or unsafe practices which could result in severe personal injury or death.

**FOR SAFETY:** To identify actions which must be followed for safe operation of equipment.

The following information signals potentially dangerous conditions to the operator or equipment:

### FOR SAFETY:

1. **Do not operate machine:**
  - Unless trained and authorized.
  - Unless operator manual is read and understood.
  - In flammable or explosive areas unless designed for use in those areas.
  - With the use of additional extension cords. Only use manufacturer's extension cord equipped with machine which has proper capacity and is grounded.
  - With damaged cord or plug.
  - If not in proper operating condition.
  - In outdoor areas.
  - In standing water.
2. **Before operating machine:**
  - Make sure all safety devices are in place and operate properly.
3. **When using machine:**
  - Do not run machine over cord.
  - Do not pull machine by plug or cord.
  - Do not pull cord around sharp edges or corners.
  - Do not unplug by pulling on cord.
  - Do not stretch cord.
  - Do not handle plug with wet hands.
  - Keep cord away from heated surfaces.
  - Report machine damage or faulty operation immediately.
  - Follow mixing and handling instructions on chemical containers.

4. **Before leaving or servicing machine:**
  - Turn off machine.
  - Unplug cord from wall outlet.
5. **When servicing machine:**
  - Unplug cord from wall outlet.
  - Avoid moving parts. Do not wear loose jackets, shirts, or sleeves.
  - Use manufacturer supplied or approved replacement parts.

**⚠ WARNING:** Hazardous Voltage. Shock or electrocution can result. Always unplug machine before servicing.

**⚠ WARNING:** Flammable materials can cause an explosion or fire. Do not use flammable materials in tank(s).

**⚠ WARNING:** Flammable materials or reactive metals can cause an explosion or fire. Do not pick up.

---

## GROUNDING INSTRUCTIONS

Machine must be grounded. If it should malfunction or breakdown, grounding provides a path of least resistance for electrical current to reduce the risk of electrical shock. This machine is equipped with a cord having an equipment-grounding conductor and grounding plug. The plug must be plugged into an appropriate outlet that is properly installed in accordance with all local codes and ordinances. Do not remove ground pin; if missing, replace plug before use.

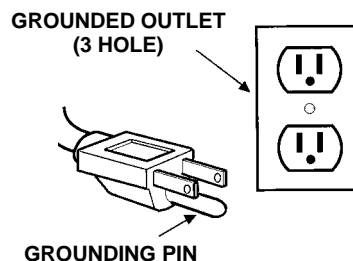

# OPERATION

## MACHINE SETUP

1. Unscrew and remove front clear lid. Fill solution tank bladder with 57 liters (15 gal) of hot water, 60°C (140°F) max. Add recommended cleaning agent to proper dilution ratio (Figure 1).

**FOR SAFETY: When using machine, follow mixing and handling instructions on chemical containers.**



FIG. 1.

**⚠ WARNING: Flammable materials can cause an explosion or fire. Do not use flammable materials in tank(s).**

**NOTE:** After filling clean water bladder, **REPLACE CLEAR LID AND TIGHTEN SECURELY.** Suction in recovery tank will overexpand solution tank bladder if cover is not sealed.

**ATTENTION:** Do not mix powdered chemicals in extractor's clean water bladder. Mix powdered chemicals thoroughly in a bucket before pouring into machine. Powders are unlikely to dissolve completely and can clog solution pump system.

**NOTE:** If using a bucket to fill and empty machine use separate buckets. Always use a clean bucket to fill machine. Dirty water in solution tank bladder will clog solution pump system.

2. Connect 7.6m (25 ft) extension power cord to machine and plug into a grounded wall outlet (Figure 2).

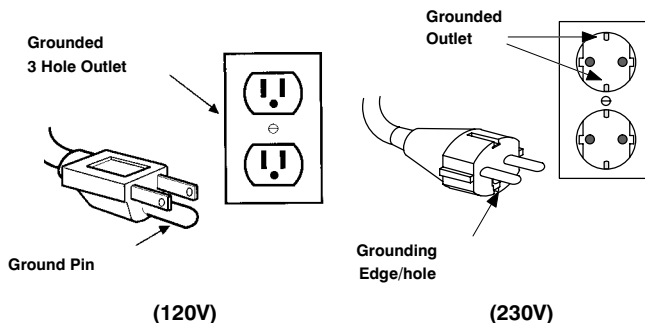

FIG. 2.

**FOR SAFETY: Do not operate machine with the use of additional extension cords. Only use manufacturer's extension cord equipped with machine which has proper capacity and is grounded.**

3. Prime solution pump:
  - a. Connect bleeder hose onto solution quick coupler located at front of extractor.
  - b. Submerge other end of bleeder hose into a bucket or back into solution tank.
  - c. Open read pressure adjustment knob completely (turn counterclockwise—see Figure 3), then turn pump switch on. As pump runs, air bubbles should dissipate in solution.
  - d. Close pressure adjustment knob completely by turning clockwise and allow pump to continue running. If properly primed, pressure should read 200–220 psi.
  - e. Now attach accessory tool.

**NOTE:** Whenever extractor runs out of solution while operating, you must always prime pump before operating.



FIG. 3.

4. Attach vacuum and solution hose to hose connectors at front of machine then to floor or hand tool (Figure 4).



FIG. 4.

## OPERATING FLOOR TOOL

**FOR SAFETY: Do not operate machine unless operator manual is read and understood.**

**NOTE:** Vacuum carpet before cleaning.

1. Activate "VACUUM" and "PUMP" switches.
2. Place floor tool so bottom of glide plate or stainless steel shoes are parallel to floor. Squeeze trigger and apply downward pressure on floor tool head and slowly pull tool backwards using both hands. Release trigger 150 mm (6 in) from end of stroke (Figure 5).



FIG. 5.

3. Push floor tool forward over same path with trigger released when returning for next stroke. Continue this pull and push method with a slight overlap of each stroke.

**NOTE:** For heavily soiled areas, repeat stroke or change angle of stroke.

**⚠ WARNING: Flammable materials or reactive metals can cause an explosion or fire. Do not pick up.**

**ATTENTION: Do not allow water or foam to enter vacuum motor. Float shut-off screen will not stop foam intake and vacuum motor damage will result (not covered by warranty). If foam develops, remove rear clear lid and pour 30mL (1 oz.) of anti-foam solution into recovery tank.**

4. When finished cleaning, turn off switches and drain recovery tank. (See DRAINING MACHINE)
5. Disconnect solution and vacuum hoses from machine and neatly coil hoses for storing.

**ATTENTION: Relieve water pressure from tool before disconnecting hose. Squeeze trigger for five seconds after turning off switches.**

## OPERATING HAND TOOL

**FOR SAFETY: Do not operate machine unless operator manual is read and understood.**

**NOTE:** This machine cleans most synthetic upholstery very well. Fabrics like Herculon and synthetic velvets will clean with excellent results. Extraction is not recommended for most cottons, silks, wools or natural fiber velvets. Check cleaning instructions sewn in furniture by manufacturer for further instructions. Extra caution should be taken with furniture that has been re-upholstered. Any material under new upholstery may bleed and discolor new fabric.

**NOTE:** Vacuum upholstery before cleaning.

1. **TEST FABRIC FOR COLORFASTNESS:** Pour a small amount of cleaning solution on a white cloth. Hold damp portion of cloth against an area of upholstery which is hidden from view. Hold it there for 60 seconds. If no color transfers to cloth, it should be safe to clean. However, always use your best judgement.

## OPERATION

---

2. Activate "VACUUM" and "PUMP" switches.
3. Adjust pressure valve knob to read 30 psi on pressure gauge (Figure 6).



FIG. 6.

4. Begin cleaning by squeezing hand tool trigger and pulling tool backwards (Figure 7).



FIG. 7.

**NOTE:** Be careful not to over wet upholstery. Overlap your strokes to avoid streaking. Go over clean areas again using only vacuum to get fabric as dry as possible.

**⚠ WARNING:** Flammable materials or reactive metals can cause an explosion or fire. Do not pick up.

5. When finished cleaning, drain recovery tank and rinse tank thoroughly (See DRAINING RECOVERY TANK).
6. Disconnect solution and vacuum hoses from machine and neatly coil hoses for storing.

**ATTENTION:** Relieve water pressure from tool before disconnecting hose. Squeeze trigger for five seconds after turning off switches.

---

## DRAINING MACHINE

---

### TO DRAIN RECOVERY TANK:

**NOTE:** When solution tank bladder is empty, recovery tank must be emptied.

1. Turn switches off and unplug power cord.

**FOR SAFETY: Before leaving or servicing machine, unplug power cord(s) from wall outlet.**

2. Remove drain hose from holder, position hose over floor drain and twist off knob to drain (Figure 8).



FIG. 8.

**ATTENTION:** If using bucket to drain machine, do not use same bucket for filling clean water bladder!

3. Replace knob tightly before cleaning again.
4. After final draining, remove rear clear lid and rinse both tank and float shut off screen thoroughly to prevent odor buildup (Figure 11).

---

### TO DRAIN SOLUTION TANK BLADDER:

1. To drain remaining solution from solution tank bladder. Disconnect solution hose and attach bleeder hose (bleeder hose supplied with machine).
2. Activate "PUMP" switch. Pump solution into a empty bucket (Figure 9).

**ATTENTION:** Before disconnecting solution hose and replacing with bleeder hose, relieve water pressure from tool before disconnecting hose. Squeeze trigger for five seconds after turning off switches.



FIG. 9.

3. Rinse solution tank bladder with clean water to prevent odor buildup. Run vacuum motor for 30 seconds to discharge any moisture. Store extractor with covers off to promote air circulation.

## MAINTENANCE

To keep machine in good working condition, simply follow machines daily, weekly and monthly maintenance procedures.

**⚠ WARNING: Hazardous Voltage. Shock or electrocution can result. Always unplug machine before servicing.**

For ease of servicing, machine tank is hinged to pivot away from chassis to allow access to inner components. Make sure tanks are empty before opening. To open extractor for servicing, follow these steps:

- a. Unplug extractor.
- b. Unlatch front two latches.
- c. Lift tank upward, away from chassis (Figure 10).



FIG. 10.

## DAILY MAINTENANCE

1. Clean machine with a non abrasive, nonsolvent cleaner.
2. Rinse tanks out thoroughly.
3. Remove any lint buildup from float shut-off screen (Figure 11).



FIG. 11.

4. Remove and rinse solution tank bladder screen.
5. Check power cord for damage, replace if necessary. Coil cord neatly after each use.
6. Remove any lodged debris from floor tool. (Use a coat hanger).
7. Check spray pattern for clogged spray tips.

## WEEKLY MAINTENANCE

1. Remove and soak spray tips in a tannin solution.

**NOTE:** Do not use pins, paper clips, etc., to unplug spray tips. This will damage spray tips.

2. **Flush pump system:** Use a tannin solution to dissolve normal alkaline chemical buildup. Follow steps below:
  - a. Mix two cups 500 mL (16 oz) of tannin solution in solution tank bladder with 7.6 liters (2 gal) of hot water, 60° C (140° F) maximum.

**FOR SAFETY: When using machine, follow mixing and handling instructions on chemical containers.**

- b. Place a bucket under spray jets to catch spray.
- c. Turn on "PUMP" switch.
- d. Squeeze trigger on tool for 30 seconds.
- e. Allow solution to remain in system for up to 6 hours in above freezing temperatures.
- f. Later, spray out tannin solution into a drain. Then run three gallons of clean water through system to flush out impurities.

# OPERATION

---

3. Check floor tool for loose shoes. If loose, tap with rubber mallet.
4. Inspect vacuum hose for holes and loose cuffs.
5. Grease pump: Solution pump must be greased every 40 hours of operation or monthly, whichever comes first. Refer to hour meter located below handle of machine to help you determine when greasing is necessary. (Each new machine is supplied with a grease gun.) Grease Gun Part No. 190022.
  - a. To grease pump, release latches on front of machine and lift tank to access pump.
  - b. Remove safety cover, by pinching tabs and pulling straight off. You will also need to remove black 1 inch plug from front of chassis.
  - c. Insert grease gun through plug hole (front of chassis) and onto grease fitting, pump plunger at most 1 to 2 times. Gun only pumps grease at last 3/4 inch of plunger travel. Be sure to push plunger all the way down! Do this slowly to allow grease to enter bearing (Figure 12).

**ATTENTION: Over greasing pump will damage seals.**

**ATTENTION: Do not use an air powered or hand lever grease gun, they will damage pump.**



**FIG.12.**

- d. With a screwdriver, apply a generous dab of grease to outer diameter of cam bearing at top and bottom where bearing contacts connecting rod.
- e. Replace grease cover and black plug.
- f. Check pump periodically and scrape out (do not wash out) any excess grease from pump cavity.

---

## MONTHLY MAINTENANCE

1. Inspect cord grip for damage. Replace if damaged. Neatly coil cord after each use.
2. Inspect tank for cracks.
3. Lubricate casters with a water resistance grease.

---

## EVERY 250 HOURS OF OPERATION

Check vacuum motor for carbon brush wear. Replace brushes when worn to a length of 10 mm (0.38 in ) or less.

---

## STORING MACHINE

Store extractor with clear lids off to promote air circulation.

**ATTENTION: Do not expose to rain. Store indoors.**

**ATTENTION: DO NOT ALLOW MACHINE TO FREEZE WITH WATER IN PUMP SYSTEM.** This can crack internal parts and cause damage, which is not covered by warranty.

---

## STORING MACHINE IN FREEZING TEMPERATURES:

1. Drain tanks thoroughly.
2. Pour 1 L (32 oz) undiluted antifreeze into water bladder.
3. Place a bucket under spray jets to catch spray.
4. Turn on "PUMP" switch.
5. Squeeze trigger on tool for 30 seconds.
6. Allow antifreeze to remain in system.

**TROUBLE SHOOTING**

<b>PROBLEM</b>	<b>CAUSE</b>	<b>SOLUTION</b>
Uneven or no spray from tips.	Dirty or plugged spray tips.	Clean or replace tips.
	Improper spray tip size or spray angle.	Replace with proper tips. Also check alignment of spray tips so all tips spray in a straight line.
	Worn spray tips.	Replace spray tips.
Leaking floor tool.	Quick coupler on floor tool faulty.	Replace quick coupler.
	Flow control valve leaking.	Install valve rebuild kit or contact Service Center.
	Hose split or fittings loose.	Replace hose and tighten fittings.
	Quick coupler and plug not fully engaged.	Reconnect quick coupler.
	Valve stem worn.	Replace or contact Service Center.
Solution pump will not operate.	Fuse blown or circuit breaker tripped in building.	Replace fuse or reset breaker.
	Faulty pump switch.	Replace faulty switch.
	Loose wiring to solution pump.	Consult wiring diagram and repair the wire.
	Faulty solution pump motor.	Replace solution pump motor.
	Thermal overload activated—motor is too hot and will automatically shut down until cool.	Let motor cool and check what caused overheat.
	Solution pump bearing freezes up, caused by not greasing.	Repair or replace.
Poor or no vacuum suction.	Fuse blown or circuit breaker tripped in building.	Find out if other appliances are plugged into same circuit. Replace fuse or reset breaker. Plug extractor into a less heavily loaded circuit.
	Faulty vacuum switch.	Replace faulty switch.
	Drain hose plug open or loose.	Plug drain hose and tighten knob.
	Lint is clogging float shutoff screen.	Remove recovery cover and clean lint off screen.
	Air is leaking around clear cover lids.	Tighten tank covers.
	Vacuum hose is loose.	Push hose firmly onto recovery tool and onto front of extractor.
	Holes in vacuum hose or hose cuffs loose on the hose.	Replace hose or thread cuffs securely onto hose.
	Faulty vacuum motor.	Replace vacuum motor.
	Faulty vacuum gasket.	Replace gasket.
	Float shutoff activated.	Turn off vac, empty tank.

TANK ASSEMBLY

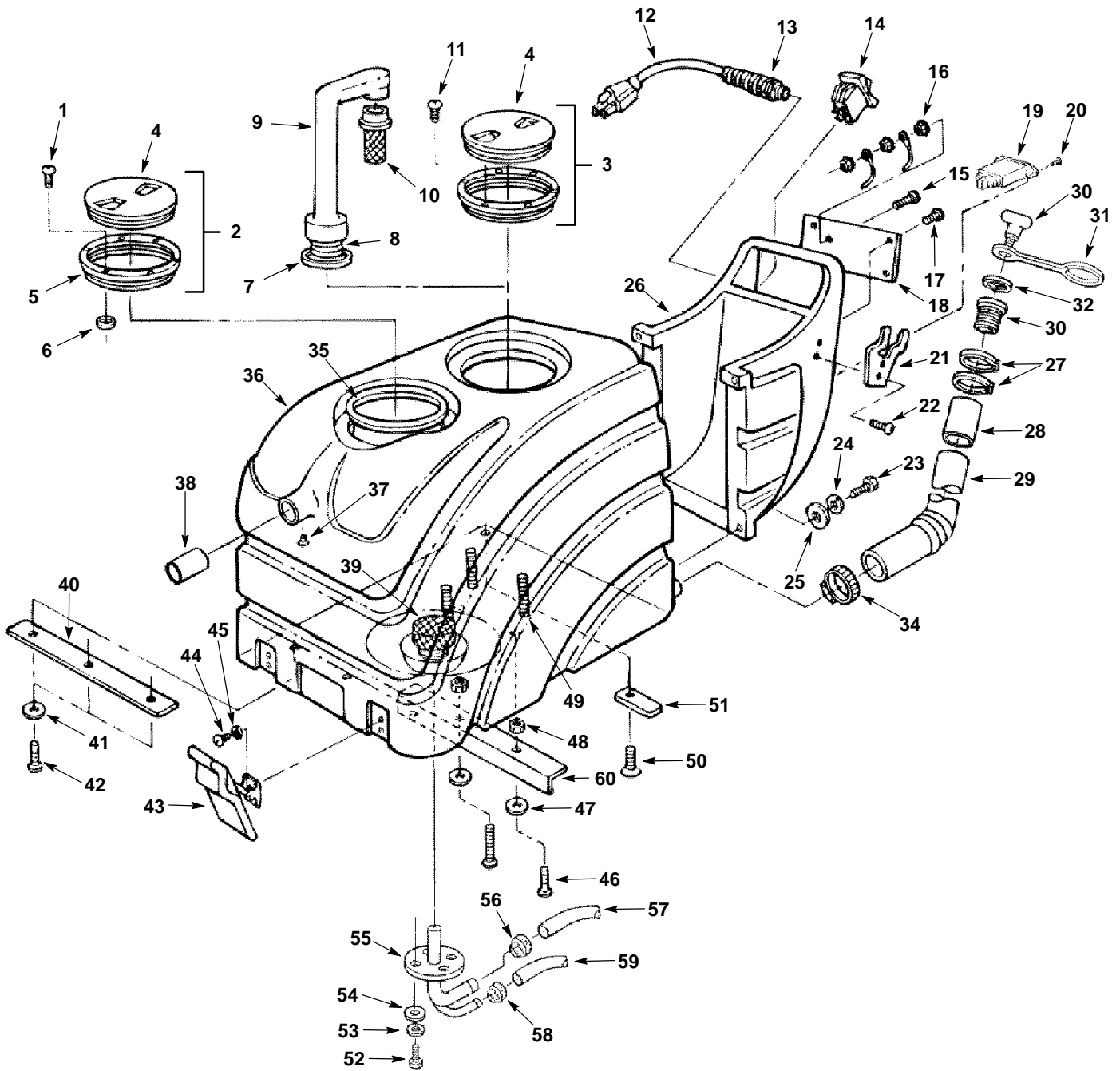

## TANK ASSEMBLY

REF	PART #	DESCRIPTION	QTY.
1	140900	SCREW, 10-24 X 3/4	6
∇2	100103	LID, CLEAR W/COUNTERSUNK HOLE	1
∇3	100102	LID, CLEAR W/STANDARD HOLE	1
▲4	100105	LID, CENTER	2
▲5	100109	LID, OUTER RING BLACK	2
6	140000	WASHER, FLAT 1.4"	6
7	101714	GASKET	1
8	230187	NIPPLE, 1 1/2" PVC	1
9	602448	STANDPIPE	1
10	180613	SCREEN, FLOAT SHUT-OFF	1
11	140825	SCREW, #6 X 1/2"	6
12	130227	CORD, 14/3 X 20" YELLOW (120V)	1
	600324	CORD, 3 X 1.5MM 2 X 15M BLACK (230V)	1
13	130166	CORD GRIP (120V)	1
	130167	CORD GRIP (230V)	1
14	19417	SWITCH, ON/OFF	1
15	140900	SCREW, 10-24 X 3/4	1
16	140519	NUT, KEP 10-24	3
17	140837	SCREW, 10-24 X 3/8"	4
18	230908.BK	PLATE, REAR	1
19	130017	HOURMETER (120V)	1
	604745	HOURMETER (230V)	1
20	140825	SCREW, 10-24 X 3/8"	4
21	230696.BK	BRACKET, DRAIN HOSE	1
22	140825	SCREW, #6 X 1/2"	2
23	140231	SCREW, 3/8 X 1-1/2	4
24	140017	WASHER, LOCK 3/8"	4
25	140028	WASHER, FLAT 3/8"	4
26	101399	HANDLE, HOUSING, BLUE	1
∇	190965	KIT, DRAIN HOSE ASM.	1
▲27	140072	CLAMP, EAR 1-9/16"	2
▲28	140921	SLEEVE, DRAIN HOSE	1
▲29	160627	HOSE, DRAIN	1
▲∇	701061	ASM., DRAIN HOSE STOPPER	1
▲30	230831	KNOB, DRAIN HOSE	1
▲31	230882	STRAP, RUBBER	1
▲32	140056	WASHER	1
▲33	140955	PLUG	1

REF	PART #	DESCRIPTION	QTY.
34	140307	CLAMP, HOSE	1
35	602783	BLADDER, SOLUTION TANK	1
36	101396	TANK, RECOVERY, BLUE	1
37	140703	RIVET, POP	1
38	230905	TUBE, INLET	1
39	180628	SCREEN, CLEAN WATER TANK	1
40	230946	BRACE, TANK	1
41	140016	WASHER, LOCK 1/4"	3
42	140259	SCREW, 1/4" 20 X 5/8	3
43	140932	LATCH, RUBBER	2
44	140801	SCREW, 8-32 X 3/8	4
45	140023	WASHER, INT LOCK #8	4
46	140208	SCREW, 1/4-20 X 1	2
47	140016	WASHER, LOCK 1/4"	2
48	140134	SPACER	2
49	140258	STUD	3
50	140834	SCREW, 1/4-20 X 5/8	1
51	230845	PLATE, CORD CLAMP	1
52	140259	SCREW, 1/4-20 X 5/8	4
53	140016	WASHER, LOCK	4
54	140000	WASHER, FLAT	4
55	600452	PLATE, BLADDER	1
56	140310	CLAMP, HOSE	1
57	603051	HOSE, 1/2" ID X 3/4 OD, 2.3'	1
58	140305	CLAMP, HOSE	1
59	606161	HOSE, 1/4" GRAY 36"	1
60	230846	BRACKET, TANK SUPPORT	1
N/S	120188	DECAL, DASH	1
N/S	120619	DECAL, "WARNING, EXTRACTOR..."	1
N/S	120906	DECAL, "IMPORTANT, DRAIN..."	1
N/S	120907	DECAL, "IMPORTANT, ALWAYS CLOSE..."	2
N/S	120190	DECAL, "USE BLEEDER HOSE..."	1
N/S	120101	DECAL, "CASTEX"	1
N/S	608219	DECAL, PX-1500HP	2

∇= ASSEMBLY  
▲= INCLUDED IN ASSEMBLY  
N/S= NOT SHOWN

CHASSIS ASSEMBLY

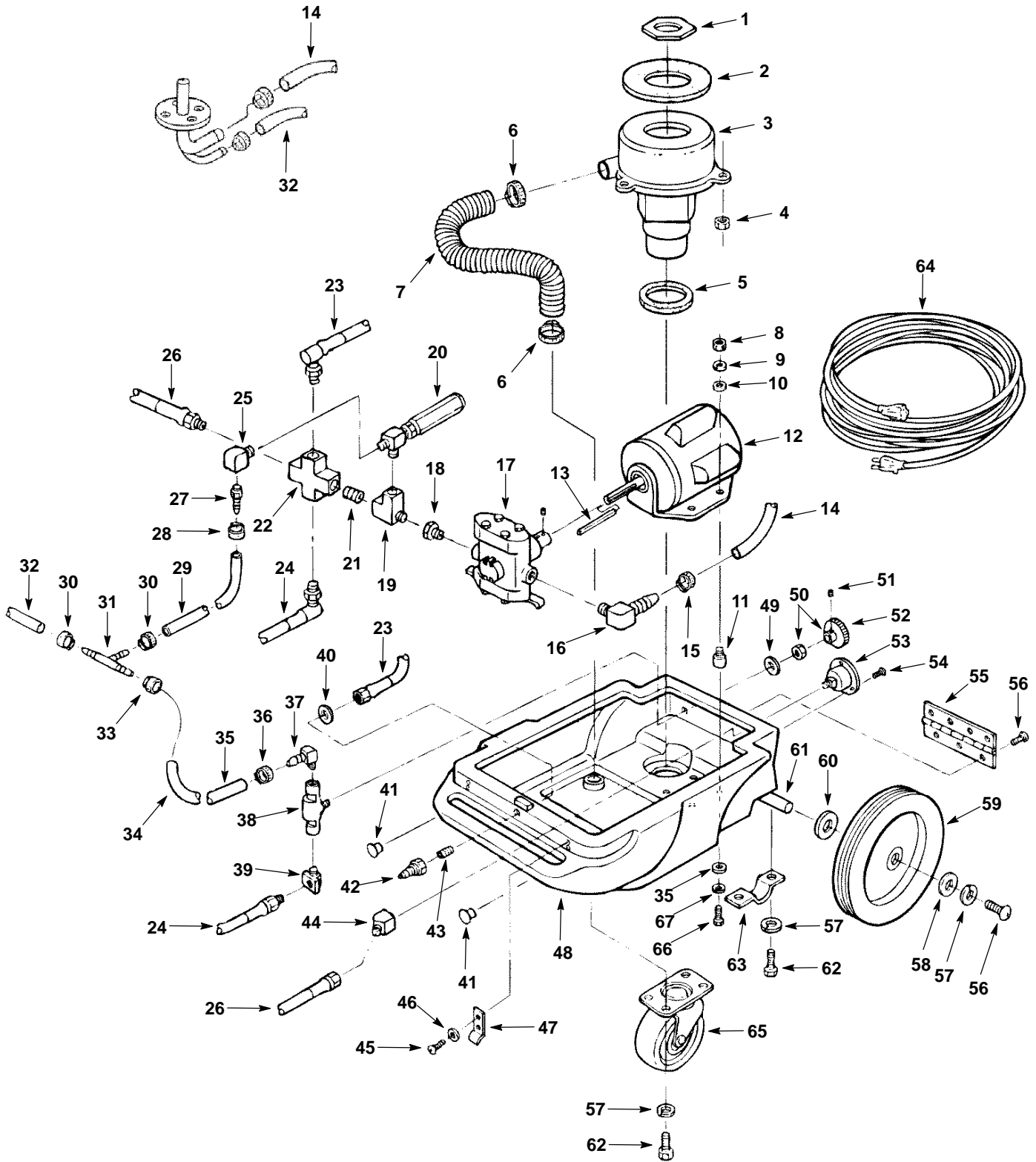

## CHASSIS ASSEMBLY

REF	PART #	DESCRIPTION	QTY.
1	210240	NUT, FLANGED 1-1/2"	1
2	100001	GASKET, VAC MOTOR	1
3	130404	MOTOR, VAC (120V)	1
	190157	CARBON BRUSHES (2/Pk)	2
	130405	MOTOR, VAC (230V)	1
	190157	CARBON BRUSHES (2/Pk)	2
4	140501	NUT, LOCK 1/4	3
5	102567	GASKET, VAC MOTOR	1
6	140308	CLAMP, HOSE	2
7	160629	HOSE, 2" X 27" WHITE	1
8	140506	NUT, HEX 5/16-18	4
9	140015	WASHER, SPLIT LOCK 5/16"	4
10	140027	WASHER, FLAT 5/16"	4
11	130031	MOUNT, MOTOR 1.25"	4
	130030	MOUNT, MOTOR 0.75" (230V)	4
12	130450	MOTOR, PUMP DRIVE 1/3 HP (120V)	1
	130453	MOTOR, PUMP DRIVE (230V)	1
13	190310	KEY, PUMP SHAFT	1
14	603051	HOSE, 1/2" ID X 3/4 OD, 2.3'	1
15	140310	CLAMP, HOSE	2
16	150431	ELBOW, 1/2 X 1/2 X 90°	1
17	180100	PUMP (SEE PAGE 14 FOR BREAKDOWN)	1
18	150101	BUSHING	1
19	150709	TEE, 1/4" ST	1
20	210211	VALVE, PRESSURE RELIEF	1
21	150615	NIPPLE, CLOSE 1/4"	1
22	150700	CROSS	1
23	701214	HOSE, HP 14" ASM.	1
24	701213	HOSE, HP 21" ASM.	1
25	150407	ELBOW 1/8 ST 90°	1
26	160140	HOSE, HP 36" ASM.	1
27	150525	HOSE BARB, 1/8" M X 1/4" H	1
28	140305	CLAMP, HOSE	1
29	606359	HOSE, 1/4" GRAY 5", .42'	1
30	140325	CLAMP, EAR 1/2	2
31	150713	TEE, UNION 1/4"	1
32	606161	HOSE, 1/4" GRAY 31", 2.6'	1

REF	PART #	DESCRIPTION	QTY.
33	140325	CLAMP, EAR 1/2	1
34	606161	HOSE, 1/4' GRAY 31", 2.6'	1
35	140027	WASHER, FLAT 5/16"	4
36	140305	CLAMP, HOSE	1
37	150418	ELBOW, 1/4" X 1/4" 90°	1
38	210108	VALVE, PRESSURE CONTROL	1
39	150406	ELBOW, STRT 1/4 X 90°	1
40	140058	WASHER	1
41	130284	PLUG, DOME 1" BLACK	2
42	150933	PLUG, QUICK COUPLER SER 60	1
43	150615	NIPPLE, CLOSE 1/4"	1
44	150403	ELBOW, STRT 1/4" X 45°	1
45	140801	SCREW, 8-32 X 3/8	4
46	140023	WASHER, INT LOCK #8	4
47	140932	LATCH, RUBBER	2
48	101397	CHASSIS, BLUE	1
49	27820	WASHER, FLAT	1
50	210108	VALVE, PRESSURE CONTROL	1
51	140894	SET SCREW 10-32 X 1/4	1
52	210023	KNOB, PRESSURE VALVE ADJUSTMENT	1
53	180201	GAUGE, PRESSURE	1
54	140825	SCREW, #6 X 1/2"	3
55	230390	HINGE, TANKS	1
56	140885	SCREW, 1/4-20 X 1/2	9
57	140016	WASHER, LOCK 1/4"	14
58	140003	WASHER, FLAT 1/4"	2
59	103009	WHEEL, 12" X 1.75"	2
60	140008	WASHER, FLAT	4
61	230907	AXLE	1
62	140259	SCREW, 1/4-20 X 5/8"	12
63	230746	BRACKET, AXLE OFFSET	2
64	130694	CORD, EXTENSION 14/3 X 25' (120V ONLY)	1
65	103065	CASTER, SWIVEL 4"	2
66	140223	SCREW, 5/16-18 X 3/4	4
67	140015	WASHER, SPLIT LOCK 5/16"	4

SOLUTION PUMP BREAKDOWN

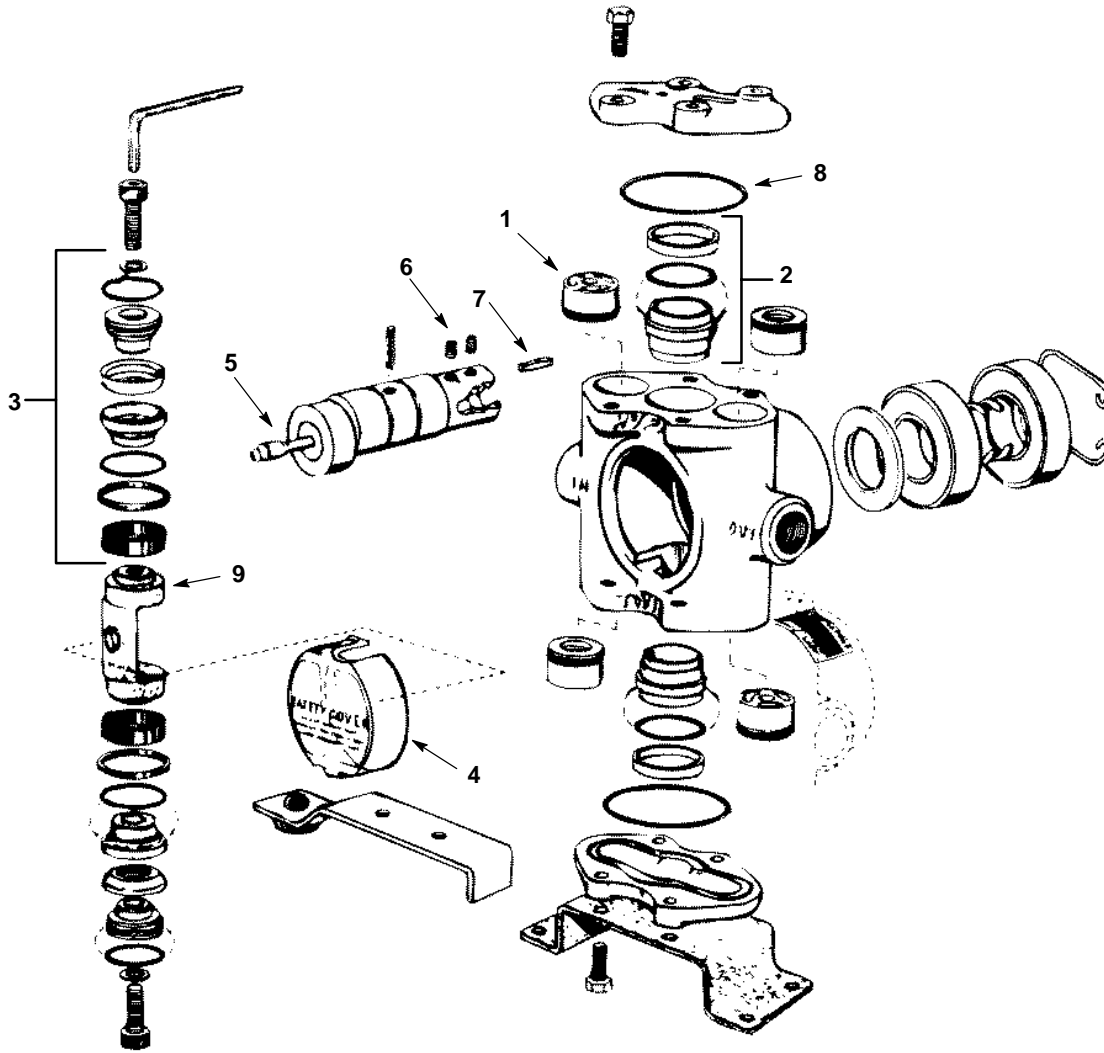

REF	PART #	DESCRIPTION	QTY.
	180100	PUMP, TWIN PISTON (COMPLETE)	1
1	190301	VALVE KIT, SET OF 4	1
2	190302	KIT, CYLINDER SLEEVE	1
3	190300	CUP KIT, SET OF 2	1
4	190307	SAFETY COVER	1
5	190305	GREASE FITTING	1
6	190309	SET SCREWS, PUMP	2

REF	PART #	DESCRIPTION	QTY.
7	190310	SHAFT KEY	1
8	190303	KIT, O-RING (INCLUDES 2 O-RINGS)	1
9	190304	CONNECTING ROD	1
N/S	190316	PULLER, VALVE SPRING RETAINER	1
N/S	190317	PULLER, VALVE, POPPET SEAT	1
N/S	190022	GUN, GREASE (METAL)	1

N/S= NOT SHOWN

120V Wiring

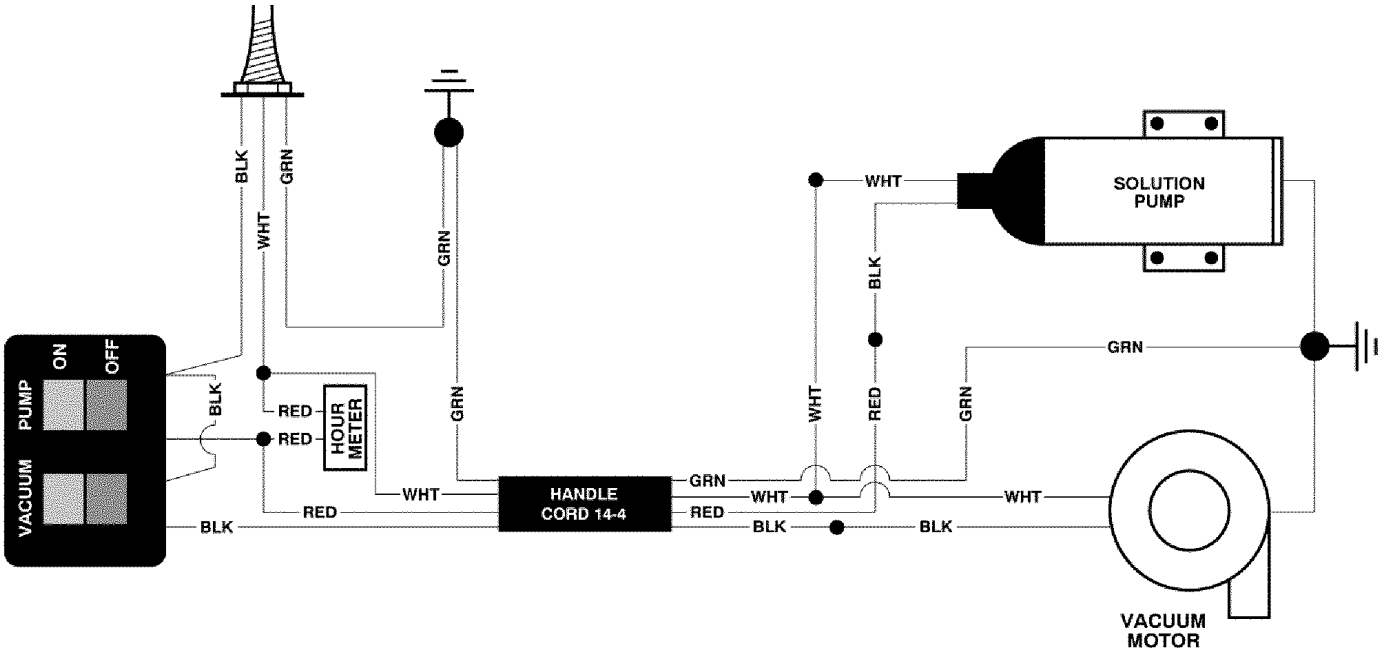

230V Wiring

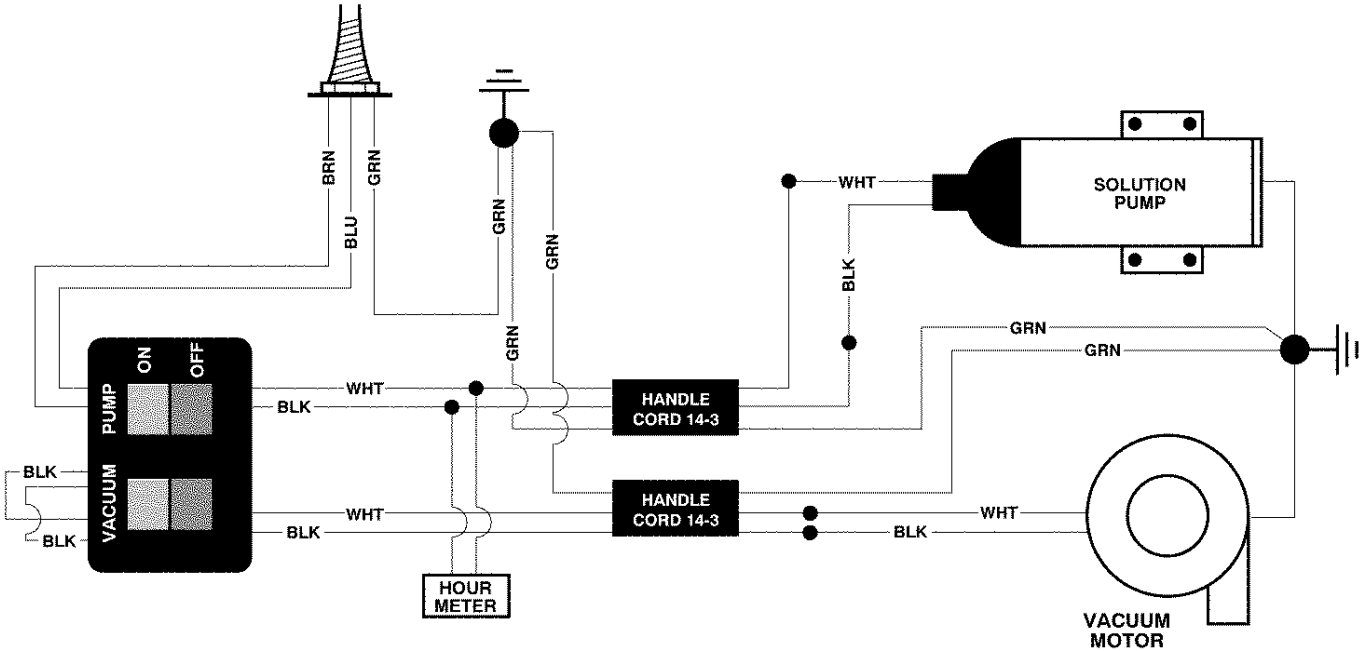

# OPTIONAL ACCESSORIES

## 127 mm (5 inch) UPHOLSTERY TOOL ASSEMBLY

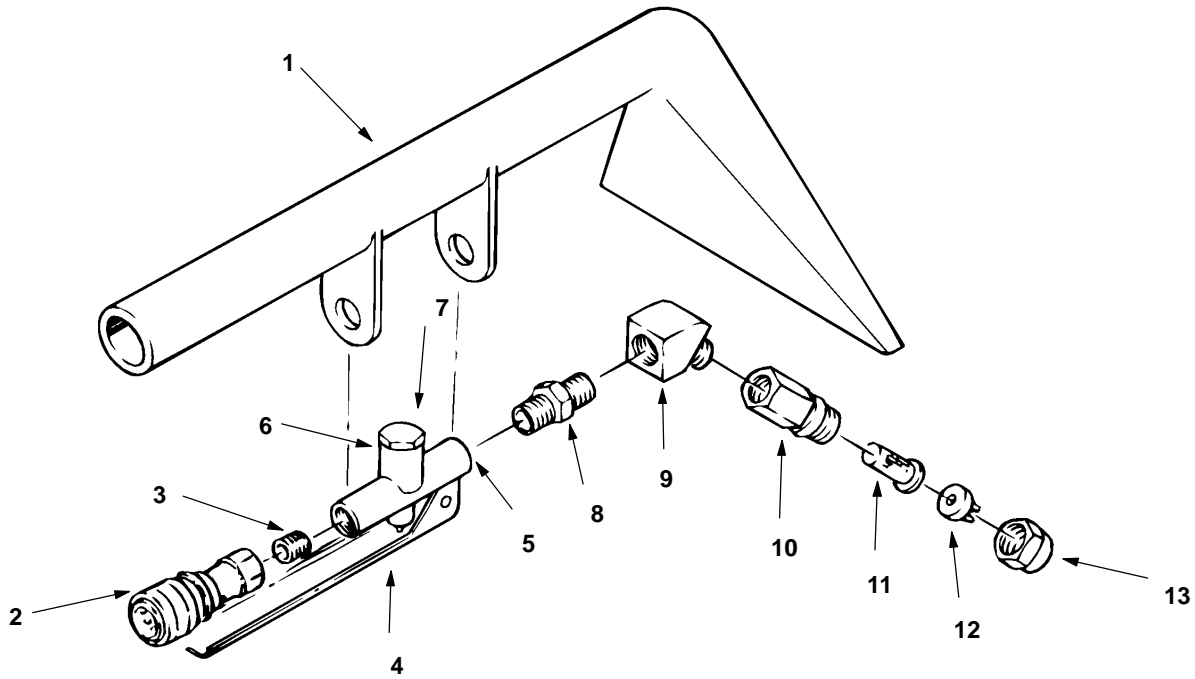

REF	PART #	DESCRIPTION	QTY.
	200505	5" HAND TOOL, (COMPLETE)	1
1.	200431.BK	TOOL, HAND	1
2.	150913	COUPLER, QUICK, SER. 60	1
3.	150615	NIPPLE, CLOSE	1
4.	200905	LEVER, K-VALVE W/PIN	1
5.	210210	VALVE, FLOW CONTROL	1
6.	190600	VALVE PIN & SPRING (NOT SHOWN)	1
7.	210148	CAP, HEX, VALVE	1

REF	PART #	DESCRIPTION	QTY.
8.	150606	NIPPLE, HEX 1/4"	1
9.	150403	ELBOW, ST 1/4" 45°	1
10.	200992	BODY, SPRAY 1/4"F	1
11.	200996	SCREEN, SPRAY BODY	1
12.	200965	TIP, BRASS #8002	1
13.	200994	CAP, SPRAY BODY	1

HIGH PRESSURE FLOOR TOOL ASSEMBLY

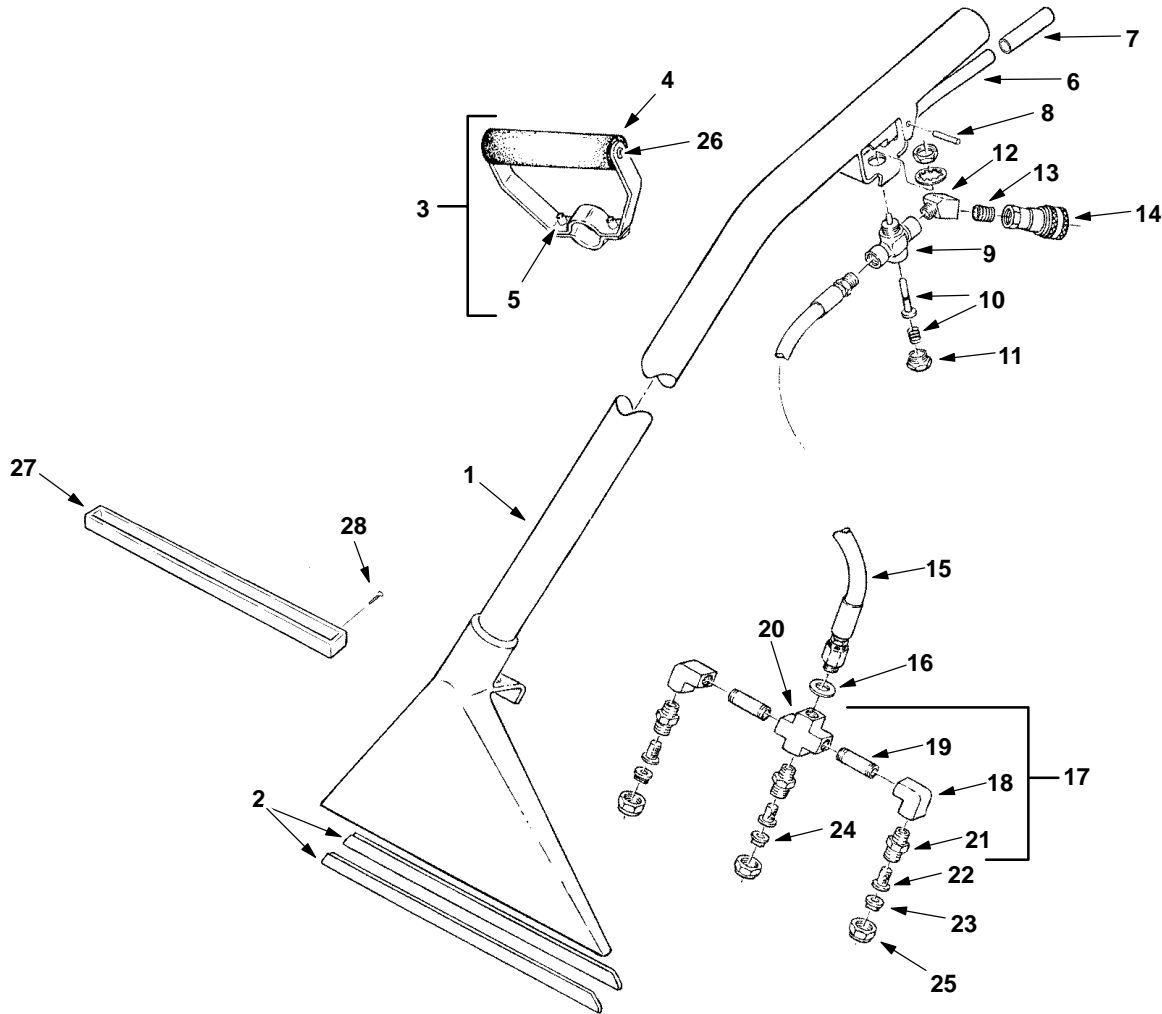

REF	PART #	DESCRIPTION	QTY.
	600049	TOOL, FLOOR (COMPLETE)	1
1	200403.BK	TOOL, FLOOR	1
2	200939	SHOES, FLOOR TOOL	2
3	200927	GRIP, ADJUSTABLE COMPLETE	1
4	200912	FOAM, GRIP	1
5	140259	SCREW, 1/4 X 5/8	2
6	200902	TRIGGER, FLOOR TOOL	1
7	200809	SLEEVE, TRIGGER	1
8	140605	PIN	1
	140520	NUT, PUSH	2
9	210150	VALVE, FLOW CONTROL	1
10	190603	KIT, VALVE PIN & SPRING	1
11	N/A	CAP, HEX, VALVE	1
12	150403	ELBOW, 1/4-45°	1
13	150615	NIPPLE, CLOSE 1/4	1
14	150913	COUPLER, QUICK SER. 60	1

REF	PART #	DESCRIPTION	QTY.
15	160175	HOSE, SOLUTION HP	1
16	140058	WASHER	1
▽17	700062	ASM., SPRAY BAR	1
▲18	150401	ELBOW, 90° 1/4F X 1/4F	2
▲19	150600	NIPPLE	2
▲20	150700	CROSS	1
▲21	200993	SPRAY BODY	3
22	200996	SCREEN, SPRAY BODY	3
23	200986	TIP, SPRAY (#9502)	2
24	200988	TIP, SPRAY (#11002)	1
25	200994	CAP, SPRAY BODY	3
26	140834	SCREW, 1/4-20 X 5/8	2
27	N/A	PLATE, GLIDE (MODEL 15017)	1
28	N/A	END FASTENERS (MODEL 15017)	2
N/S	120845	DECAL, "HIGH PRESSURE" (NOT SHOWN)	1

▽= ASSEMBLY  
▲= INCLUDED IN ASSEMBLY

# OPTIONAL ACCESSORIES

## SOLUTION AND VACUUM HOSES

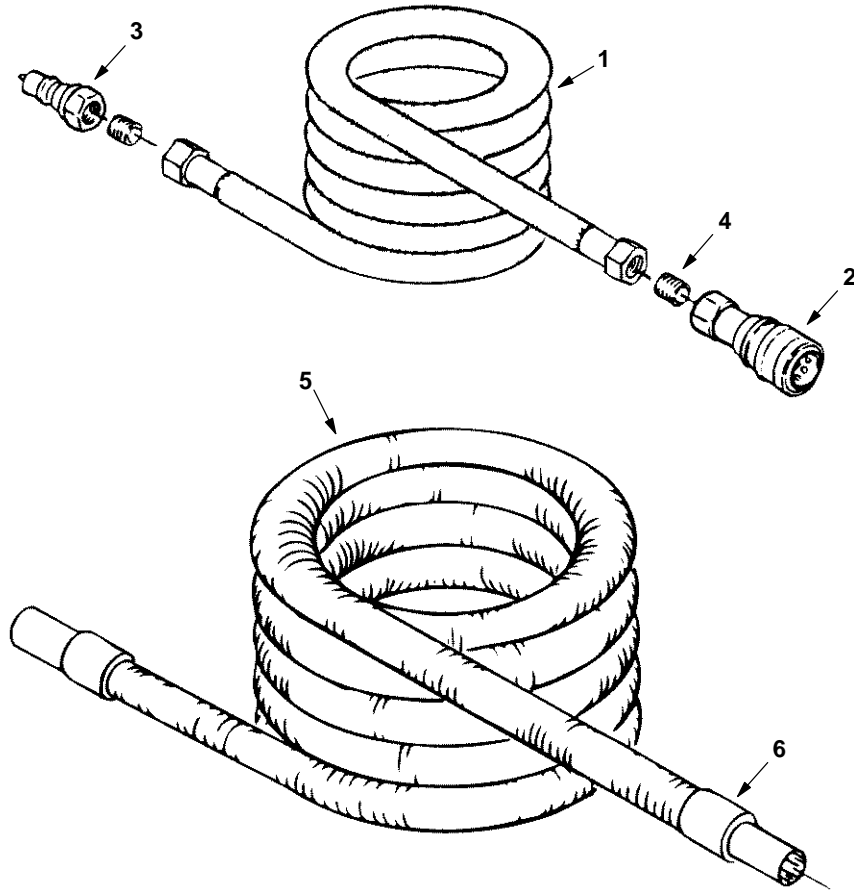

REF	PART #	DESCRIPTION	QTY.
▽1	160191	SOLUTION HOSE 25'	1
▲2	150913	COUPLER, QUICK SER. 60	1
▲3	150933	PLUG, QUICK COUPLER	1
▲4	150615	NIPPLE	2
▽5	160401	VACUUM HOSE W/ CUFFS 1-1/2" X 25'	1
▲6	160430	CUFF, HOSE 1-1/2"	2
N/S	160451	CONNECTOR, VAC HOSE 1-1/2"	1

▽= ASSEMBLY  
 ▲= INCLUDED IN ASSEMBLY  
 N/S= NOT SHOWN