

Castex®

PX-1500HPH

Carpet Extractor with Heat

Model No.:
608218

Operator and Parts Manual

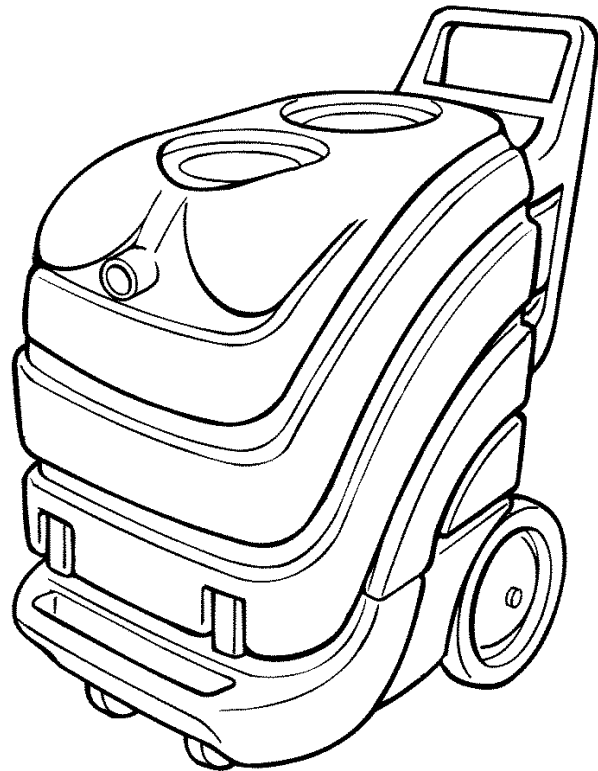

CASTEX
12875 RANSOM STREET
HOLLAND MI 49424 U.S.A.

FAX: 1-800-678-4240
CUSTOMER SERVICE: 1-800-964-9644

608701
Rev. 00 (06-99)

This manual is furnished with each new model. It provides necessary operation and machine maintenance instructions and an illustrated parts list. **Read this manual completely and understand the machine before operating or servicing it.**

Use the illustrated Parts Lists to order parts. Before ordering parts or supplies, be sure to have your machine model number and serial number handy. Parts and supplies may be ordered by phone or mail from any authorized parts and service center, distributor or from any of the manufacturer's subsidiaries.

This machine will provide excellent service. However, the best results will be obtained at minimum costs if:

- The machine is operated with reasonable care.
- The machine is maintained regularly - per the machine care instructions provided.
- The machine is maintained with manufacturer supplied or equivalent parts.

MACHINE DATA

Please fill out at time of installation for future reference.	
Model No.-	_____
Install. Date -	_____
Serial No.-	_____

© 1999 Tennant Company Printed in U.S.A.

TABLE OF CONTENTS

SAFETY PRECAUTIONS	4
MACHINE SETUP	5
OPERATING FLOOR TOOL	6
OPERATING HAND TOOL	7
DRAINING MACHINE	7
MAINTENANCE	8
STORING MACHINE	10
RECOMMENDED STOCK ITEMS	10
TROUBLE SHOOTING	11
ELECTRICAL DIAGRAM	12
PARTS LIST	13
OPTIONAL ACCESSORIES	21

OPERATION

SAFETY PRECAUTIONS

This machine is suited to clean carpet and upholstery in an indoor environment and is not constructed for any other use. Use only recommended accessory tools and cleaning solutions.

All operators must read, understand and exercise the following Important Safety Instructions.

The following safety alert symbols are used throughout this manual as indicated in their description.

⚠ WARNING: To warn of hazards or unsafe practices which could result in severe personal injury or death.

FOR SAFETY: To identify actions which must be followed for safe operation of equipment.

The following information signals potentially dangerous conditions to the operator or equipment:

FOR SAFETY:

1. Do not operate machine:
 - Unless trained and authorized.
 - Unless operator manual is read and understood.
 - In flammable or explosive areas unless designed for use in those areas.
 - With damaged cord or plug.
 - If not in proper operating condition.
 - In outdoor areas.
 - In standing water.
 - With the use of additional extension cords. Only use manufacturer's extension cord equipped with machine which has proper capacity and is grounded.
2. Before operating machine:
 - Make sure all safety devices are in place and operate properly.
3. When using machine:
 - Do not run machine over cord.
 - Do not pull machine by plug or cord.
 - Do not pull cord around sharp edges or corners.
 - Do not unplug by pulling on cord.
 - Do not stretch cord.
 - Do not handle plug with wet hands.
 - Keep cord away from heated surfaces.
 - Report machine damage or faulty operation immediately.
 - Follow mixing and handling instructions on chemical containers.

4. Before leaving or servicing machine:
 - Turn off machine.
 - Unplug cord from wall outlet.
5. When servicing machine:
 - Unplug cord from wall outlet.
 - Avoid moving parts. Do not wear loose jackets, shirts, or sleeves.
 - Use manufacturer supplied or approved replacement parts.

⚠ WARNING: Hazardous Voltage. Shock or electrocution can result. Always unplug machine before servicing.

⚠ WARNING: Flammable materials can cause an explosion or fire. Do not use flammable materials in tank(s).

⚠ WARNING: Flammable materials or reactive metals can cause an explosion or fire. Do not pick up.

GROUNDING INSTRUCTIONS:

This machine must be grounded. If it should malfunction or breakdown, grounding provides a path of least resistance for electrical current to reduce the risk of electric shock. This machine is equipped with a cord having an equipment-grounding conductor and grounding plug. The plug must be plugged into an appropriate outlet that is properly installed in accordance with all local codes and ordinances. Do not remove ground pin, if missing replace plug before use.

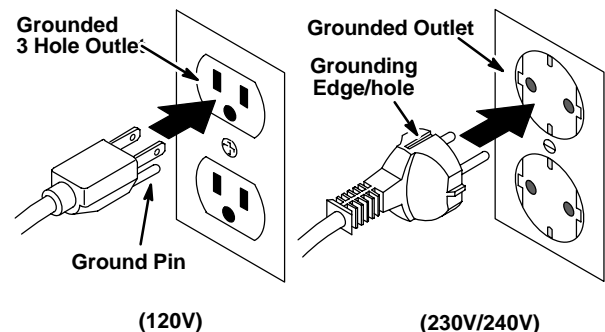

MACHINE SETUP

1. Unscrew and remove front clear lid. Fill solution tank bladder with 57 L (15 gal) of hot water, 60°C (140°F) max. Add recommended cleaning agent to proper dilution ratio (Figure 1).

FOR SAFETY: When using machine, follow mixing and handling instructions on chemical containers.



FIG. 1

⚠ WARNING: Flammable materials can cause an explosion or fire. Do not use flammable materials in tank(s).

NOTE: After filling solution tank bladder, replace clear lid and tighten securely. Suction in recovery tank will overexpand solution tank bladder if lid is not sealed.

ATTENTION: Do not mix powdered chemicals in extractor's solution tank bladder. Mix powdered chemicals thoroughly in a bucket before pouring into machine. Powders are unlikely to dissolve completely and can clog solution pump system.

NOTE: If using a bucket to fill and empty machine use separate buckets. Always use a clean bucket to fill machine. Dirty water in solution tank bladder will clog solution pump system.

2. Connect two 7.6 m (25 ft) extension power cords into machine.

FOR SAFETY: Do not operate machine with the use of additional extension cords. Only use manufacturer's extension cord equipped with machine which has proper capacity and is grounded.

3. Plug each extension cord into separate grounded circuits. Circuit indicator lamp (green) will light when cords are on separate circuits (Figure 2).

ATTENTION: When plugging extension cords into receptacles be certain to use separate circuits. This will prevent a circuit overload. Do not activate heater if green indicator does not light.



FIG. 2

4. Prime solution pump:
 - a. Connect bleeder hose onto solution quick coupler located at front of extractor.
 - b. Submerge other end of bleeder hose into a bucket or back into solution tank.
 - c. Open rear pressure adjustment knob completely, turn counterclockwise, then turn pump switch on. As pump runs, air bubbles should dissipate in solution (Figure 3).
 - d. Close pressure adjustment knob completely by turning clockwise and allow pump to continue running. If properly primed, pressure should read 200–220 psi.
 - e. Now attach accessory tool.

NOTE: Whenever extractor runs out of solution while operating, you must always prime pump before operating.



FIG. 3

5. Preheat solution. To maintain or to increase solution temperature before operating extractor, rotate preheat/clean knob to read "PREHEAT" (Figure 4). Activate "PUMP" and "HEATER" switches. Solution temperature will rise approximately 0.55°C (1°F) per minute with a full solution tank. Maximum achievable solution temperature is approximately 66°C (150°F).

OPERATION

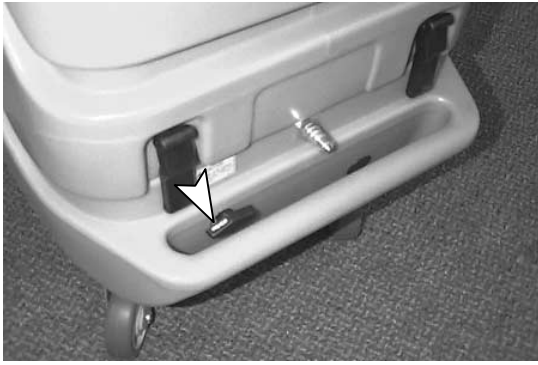

FIG. 4

6. Attach vacuum and solution hose to hose connectors at front of machine then to floor or hand tool (Figure 5).



FIG. 5

7. Turn "PUMP" and "HEATER" switches off when solution reaches up to a maximum temperature of approximately 66°C (150°F). Rotate preheat/clean knob to read "CLEAN" (Figure 6). While operating, the "CLEAN" mode will raise the existing solution temperature approximately 11°C (20°F) at the spray tips. *Example: A solution tank temperature of 66°C (150°F) will increase to a maximum temperature of approximately 77°C (170°F) at the spray tips.*

ATTENTION: DO NOT switch from "PREHEAT" to "CLEAN" mode when pump switch is activated, pump and gauge damage may occur (not covered by warranty). Always turn pump switch off before turning preheat/clean knob.

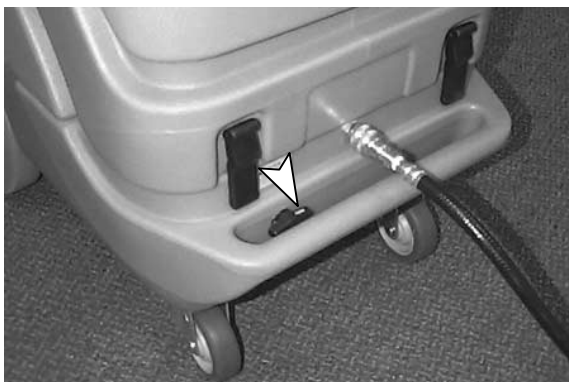

FIG. 6

NOTE: In order to get optimum water heat at spray tips while operating, keep preheat/clean knob in "CLEAN" mode. Cleaning in "PREHEAT" mode will not harm machine, this will only prevent optimum water heat at spray tips.

OPERATING FLOOR TOOL

FOR SAFETY: Do not operate machine unless operator manual is read and understood.

NOTE: Vacuum carpet before cleaning.

1. Activate "VACUUM", "PUMP" and "HEATER" switches.

NOTE: Be certain that circuit indicator light is on to verify that two separate circuits are being used.

2. Place floor tool so bottom of glide plate or stainless steel shoes are parallel to floor. Squeeze trigger and apply downward pressure on floor tool head and slowly pull tool backwards using both hands. Release trigger 152 mm (6 in) from end of stroke (Figure 7).

⚠ WARNING: Flammable materials or reactive metals can cause explosion or fire. Do not pick up.



FIG. 7

3. Push floor tool forward over same path with trigger released when returning for next stroke. Continue this pull and push method with a slight overlap of each stroke.

NOTE: For heavily soiled areas, repeat stroke or change angle of stroke.

ATTENTION: Do not allow water or foam to enter vacuum motor. Float shut-off screen will not stop foam intake and vacuum motor damage will result (not covered by warranty). If foam develops, remove rear clear lid and pour 30 ml (1 oz) of anti-foam solution into recovery tank.

4. When finished cleaning, turn off switches and drain recovery tank (See DRAINING MACHINE).

5. Disconnect solution and vacuum hoses from machine and neatly coil hoses for storing.

ATTENTION: Relieve water pressure from tool before disconnecting hose. Squeeze trigger for five seconds after turning off switches.

OPERATING HAND TOOL

FOR SAFETY: Do not operate machine unless operator manual is read and understood.

NOTE: This machine cleans most synthetic upholstery very well. Fabrics like Herculon and synthetic velvets will clean with excellent results. Extraction is not recommended for most cottons, silks, wools or natural fiber velvets. Check cleaning instructions sewn in furniture by manufacturer for further instructions. Extra caution should be taken with furniture that has been re-upholstered. Any material under new upholstery may bleed and discolor new fabric.

NOTE: Vacuum upholstery before cleaning.

1. TEST FABRIC FOR COLORFASTNESS: Pour a small amount of cleaning solution on a white cloth. Hold damp portion of cloth against an area of upholstery which is hidden from view. Hold it there for 60 seconds. If no color transfers to cloth, it should be safe to clean. However, always use your best judgement.

ATTENTION: Be certain the circuit indicator light is on to verify that two separate circuits are being used.

2. Activate "VACUUM", "PUMP" and "HEATER" switches.
3. Adjust pressure valve knob to read 30 psi on pressure gauge (Figure 8).



FIG. 8

4. Begin cleaning by squeezing hand tool trigger and pulling tool backwards (Figure 9).

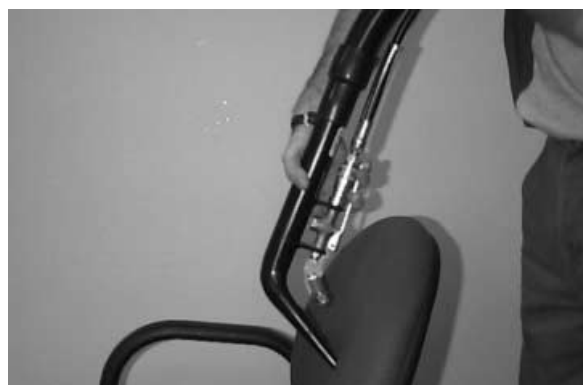

FIG. 9

NOTE: Be careful not to over wet upholstery. Overlap your strokes to avoid streaking. Go over clean areas again using only vacuum to get fabric as dry as possible.

5. When finished cleaning, drain recovery tank and rinse tank thoroughly (See DRAINING MACHINE).
6. Disconnect solution and vacuum hoses from machine and neatly coil hoses for storing.

ATTENTION: Relieve water pressure from tool before disconnecting hose. Squeeze trigger for five seconds after turning off switches.

DRAINING MACHINE

TO DRAIN RECOVERY TANK:

NOTE: When solution tank bladder becomes empty, recovery tank must be emptied.

1. Turn switches off and unplug power cord.

FOR SAFETY: Before leaving or servicing machine, unplug power cord(s) from wall outlets.

2. Remove drain hose from holder, position hose over floor drain and twist off knob to drain (Figure 10).



FIG. 10

OPERATION

NOTE: If using bucket to drain machine, do not use same bucket for filling clean water bladder!

3. Replace knob tightly before cleaning again.
4. After final draining, remove recovery tank lid and rinse tank and shut off float screen thoroughly.

TO DRAIN SOLUTION TANK:

1. To drain remaining solution from solution tank, disconnect solution hose and attach bleeder hose (bleeder hose supplied with machine).

ATTENTION: Before disconnecting solution hose and replacing with bleeder hose, relieve water pressure from tool before disconnecting hose. Squeeze trigger for five seconds after turning off switches.

2. Activate "PUMP" switch. Pump solution into an empty bucket (Figure 11).



FIG. 11

3. Rinse solution tank with clean water to prevent odor buildup. Run vacuum motor for 30 seconds to discharge any moisture. Store extractor with covers off to promote air circulation.

MAINTENANCE

To keep machine in good working condition, simply follow machine's daily, weekly and monthly maintenance procedures.

⚠ WARNING: Hazardous voltage. Shock or electrocution can result. Unplug power cord(s) before servicing machine.

For ease of servicing, machine tank is hinged to pivot away from chassis to allow access to inner components. Make sure tanks are empty before opening. To open extractor for servicing, follow these steps:

- a. Unplug power cords from wall outlets.
- b. Unlatch two latches at front of machine.
- c. Lift tank upward, away from chassis (Figure 12).



FIG. 12

DAILY MAINTENANCE

1. Clean machine's exterior surfaces with a non-abrasive, nonsolvent cleaner.
2. Drain and rinse tanks thoroughly.
3. Remove any lint buildup from float shut-off screen (Figure 13).



FIG. 13

4. Remove and rinse bladder tank screen.
5. Check power cords for damage, replace if necessary. Coil cords neatly after each use.
6. Remove any lodged debris from floor tool.
7. Check spray pattern for clogged spray tips.

WEEKLY MAINTENANCE

1. Remove and soak spray tips in a *tannin* solution.

ATTENTION: Do not use pins, paper clips, etc., to unplug spray tips. This will damage spray tips.

2. Flush pump system: Use a *tannin* solution to dissolve normal alkaline chemical buildup. Follow steps below:

FOR SAFETY: When using machine, follow mixing and handling instructions on chemical containers.

- a. Mix 500 ml (16 oz) of *tannin* solution with 7.6 L (2 gal) of hot water 60° C (140° F) maximum inside solution tank.
 - b. Place a bucket under spray jets to catch spray.
 - c. Turn on "PUMP" switch.
 - d. Squeeze trigger on tool for 30 seconds.
 - e. Allow solution to remain in system for up to 6 hours in above freezing temperatures.
 - f. Later, spray out *tannin* solution into a drain. Then run 11.4 L (3 gal) of clean water through system to flush out impurities.
3. Check floor tool for loose shoes. If loose, tap with rubber mallet.
 4. Inspect vacuum hose for holes and loose cuffs.
 5. Grease pump: Solution pump must be greased every 40 hours of operation or monthly, whichever comes first. Refer to hour meter located below handle of machine to help you determine when greasing is necessary. Each new machine is supplied with a grease gun. (Grease Gun Part No. 190022).
 - a. To grease pump, release latches on front of machine and lift tank to access pump.
 - b. Remove safety cover by pinching tabs and pulling straight off. You will also need to remove black plug from front of chassis.
 - c. Insert grease gun through plug hole (front of chassis) and onto grease fitting, pump plunger at most 1 to 2 times. Gun only pumps grease at last 19 mm (0.75 in) of plunger travel. Be sure to push plunger all the way down! Do this slowly to allow grease to enter bearing (Figure 14).

ATTENTION: Overgreasing pump will damage seals.

ATTENTION: Do not use an air powered or hand lever grease gun, they will damage pump.



FIG. 14

- d. With a screwdriver, apply a generous dab of grease to outer diameter of cam bearing at top and bottom where bearing contacts connecting rod.
- e. Replace grease cover and black plug.
- f. Check pump periodically and scrape out (do not wash out) any excess grease from pump cavity.

MONTHLY MAINTENANCE

1. Inspect cord grips for damage. Replace if damaged. Neatly coil cords after each use.
2. Inspect tank for cracks.
3. Lubricate casters with a water resistant grease.

EVERY 250 HOURS OF OPERATION

Check vacuum motor for carbon brush wear. Replace brushes when worn to a length of 10 mm (0.38 in) or less.

OPERATION

STORING MACHINE

Store extractor with clear lids off to promote air circulation.

ATTENTION: Do not expose to rain. Store indoors.

ATTENTION: DO NOT ALLOW MACHINE TO FREEZE WITH WATER IN PUMP SYSTEM. This can crack internal parts and cause damage, which is not covered by warranty.

STORING MACHINE IN FREEZING TEMPERATURES

1. Drain tanks thoroughly.
2. Pour 1 L (32 oz) undiluted antifreeze into water bladder.
3. Place a bucket under spray jets to catch spray.
4. Turn on "PUMP" switch.
5. Squeeze trigger on tool for 30 seconds.
6. Allow antifreeze to remain in system.

RECOMMENDED STOCK ITEMS

Refer to Parts List section for recommended stock items. Stock Items are clearly identified with a bullet preceding the parts description. See example below:



Ref.	Part No.	Description	Qty.
1	701103	ASM., STANDPIPE	1
2	180613	●FLOAT, SHUTOFF	1
3	230187	NIPPLE	1
4	101714	●BASKET	1
5	210240	NUT, FLANGED	1

TROUBLE SHOOTING

PROBLEM	CAUSE	SOLUTION
Uneven or no spray from tips.	Dirty or plugged spray tips.	Clean or replace tips.
	Improper spray tip size or spray angle.	Replace with proper tips. Also check alignment of spray tips so all tips spray in a straight line.
	Worn spray tips.	Replace spray tips.
Leaking floor tool.	Quick coupler on floor tool faulty.	Replace quick coupler.
	Flow control valve leaking.	Install valve rebuild kit or contact Service Center.
	Hose split or fittings loose.	Replace hose and tighten fittings.
	Quick coupler and plug not fully engaged.	Reconnect quick coupler.
	Valve stem worn.	Replace or contact Service Center.
Solution pump will not operate.	Fuse blown or circuit breaker tripped in building.	Replace fuse or reset breaker.
	Faulty pump switch.	Replace faulty switch.
	Loose wiring to solution pump.	Consult wiring diagram and repair the wire.
	Faulty solution pump motor.	Replace solution pump motor.
	Thermal overload activated—motor is too hot and will automatically shut down until cool.	Let motor cool and check what caused overheat.
	Solution pump bearing freezes up, caused by not greasing.	Repair or replace.
Poor or no vacuum suction.	Fuse blown or circuit breaker tripped in building.	Find out if other appliances are plugged into same circuit. Replace fuse or reset breaker. Plug extractor into a less heavily loaded circuit.
	Faulty vacuum switch.	Replace faulty switch.
	Drain hose plug open or loose.	Plug drain hose and tighten knob.
	Lint is clogging float shutoff screen.	Remove recovery cover and clean lint off screen.
	Air is leaking around clear cover lids.	Tighten tank lids.
	Vacuum hose is loose.	Push hose firmly onto recovery tool and onto front of extractor.
	Holes in vacuum hose or hose cuffs loose on the hose.	Replace hose or thread cuffs securely onto hose.
	Faulty vacuum motor.	Replace vacuum motor.
	Faulty vacuum gasket.	Replace gasket.
	Float shut-off activated.	Empty recovery tank.
Water not heating.	Thermostat failed.	Replace Thermostat.
	Loose wires to heater.	Consult wiring diagram and repair.
	Limit Thermostat breaker tripped or has failed.	Reset Limit Thermostat or replace.

ELECTRICAL DIAGRAM

120V Wiring

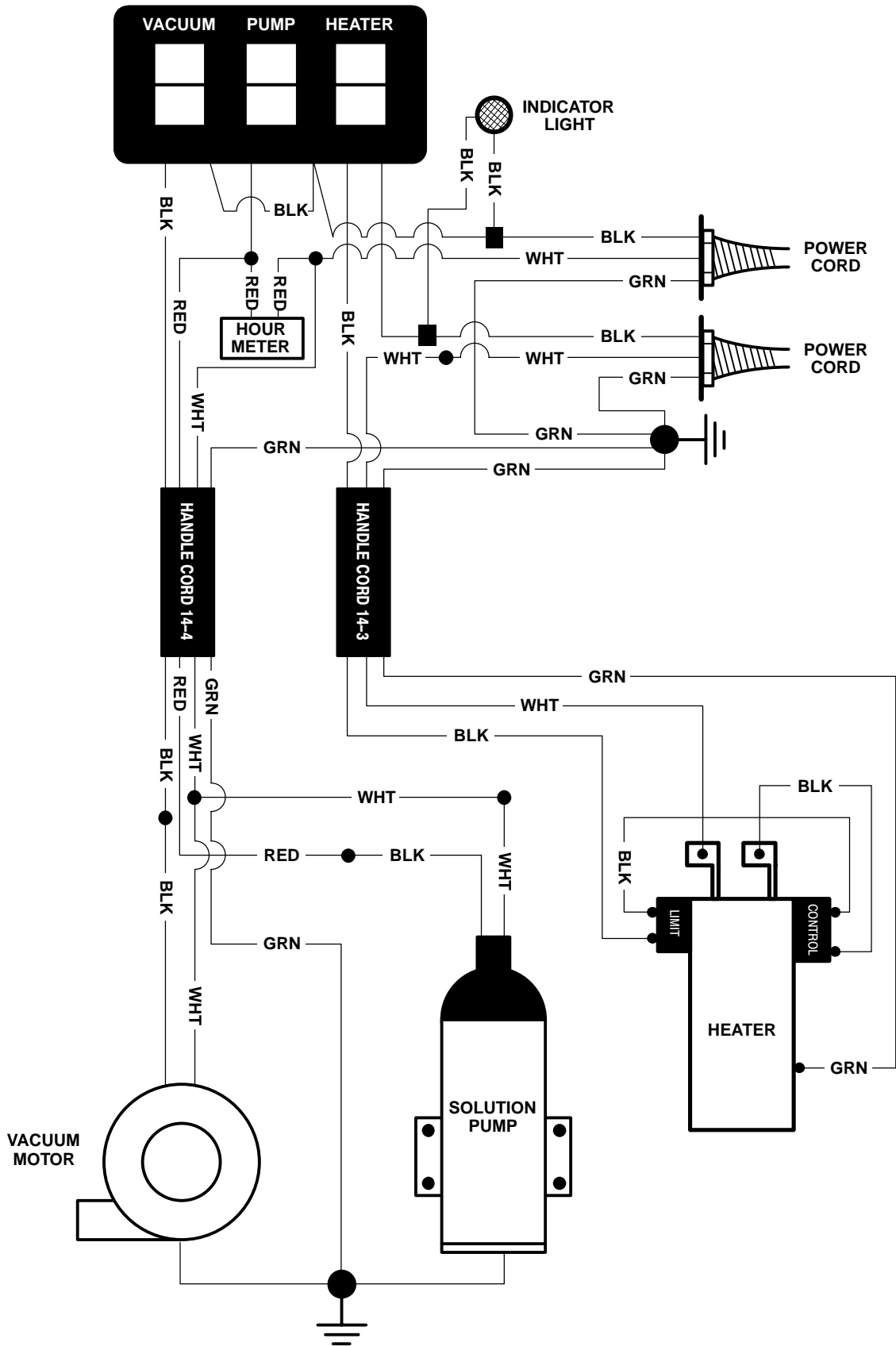

HANDLE GROUP

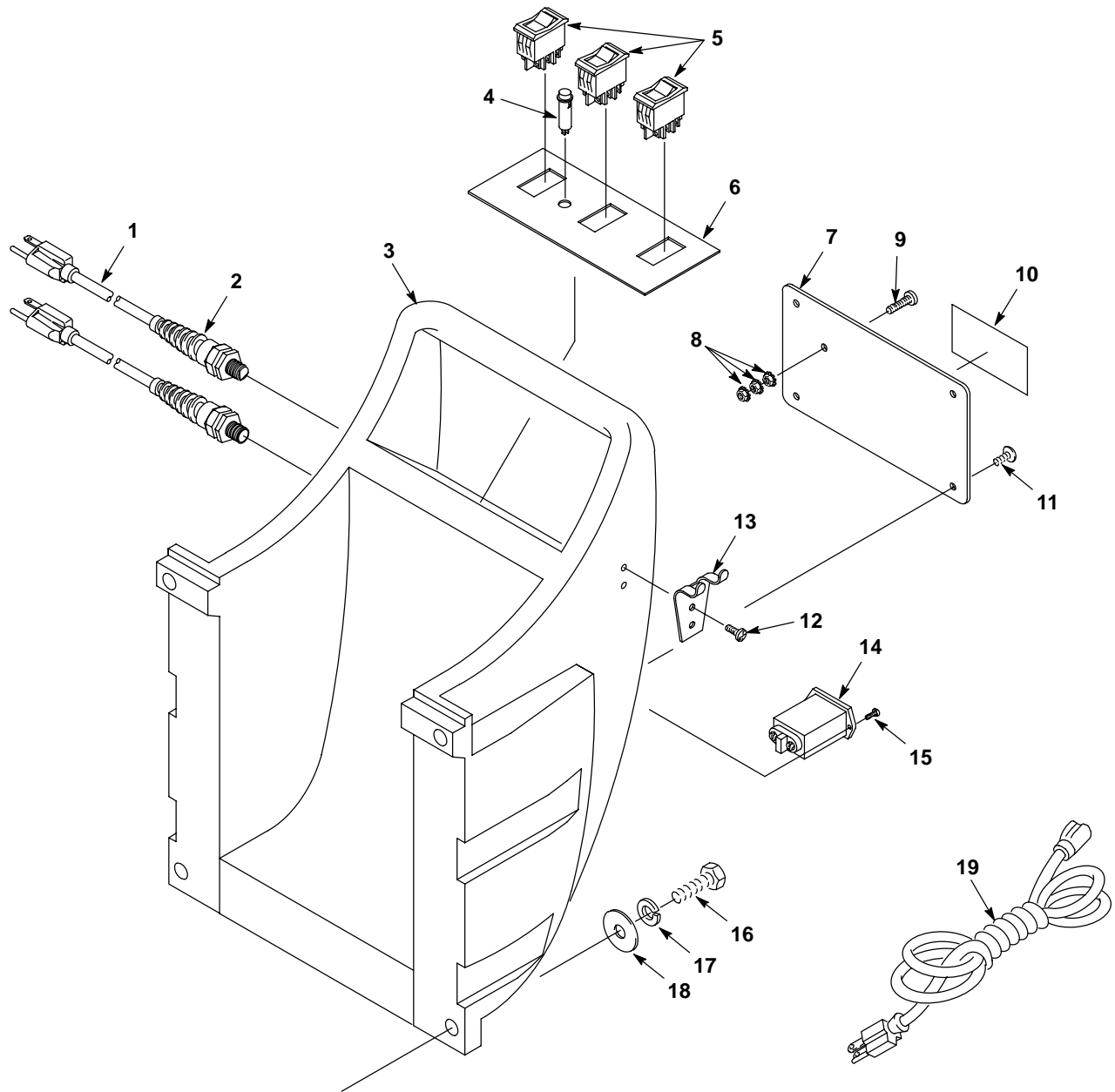

REF	PART #	DESCRIPTION	QTY.
1	130227	●CORD, 14/3 X 20" YELLOW	2
2	130166	●CORD GRIP, NYLON/BLK W/NUT	2
3	101285	HANDLE, BLUE	1
4	130691	●LIGHT, INDICATOR – GREEN	1
5	19417	●SWITCH, WITH ON/OFF	3
6	120189	DECAL, DASH	1
7	230908.BK	PLATE, REAR COVER BLACK	1
8	140519	NUT 10–24 KEP	3
9	140900	SCREW 10–24X3/4 TRSPHL	1
10	120619	DECAL, WARNING EXTRACTORS	1

REF	PART #	DESCRIPTION	QTY.
11	140197	SCREW 10–24X3/8 TRSPHL	4
12	140825	SCREW #6X1/2 PANPHL	2
13	230696.BK	BRACKET, DRAIN HOSE HANGER	1
14	130017	METER, HOUR–RECTANGULAR	1
15	140825	SCREW #6X1/2 PANPHL	2
16	140231	SCREW, HXHDCP 3/8X1–1/2	4
17	140017	WASHER 3/8 SPLTLCK	4
18	140028	WASHER 3/8 FLT	4
19	130694	●CORD, EXT 14/3X25' YELLOW	2

● RECOMMENDED STOCK ITEMS

UPPER HOUSING GROUP

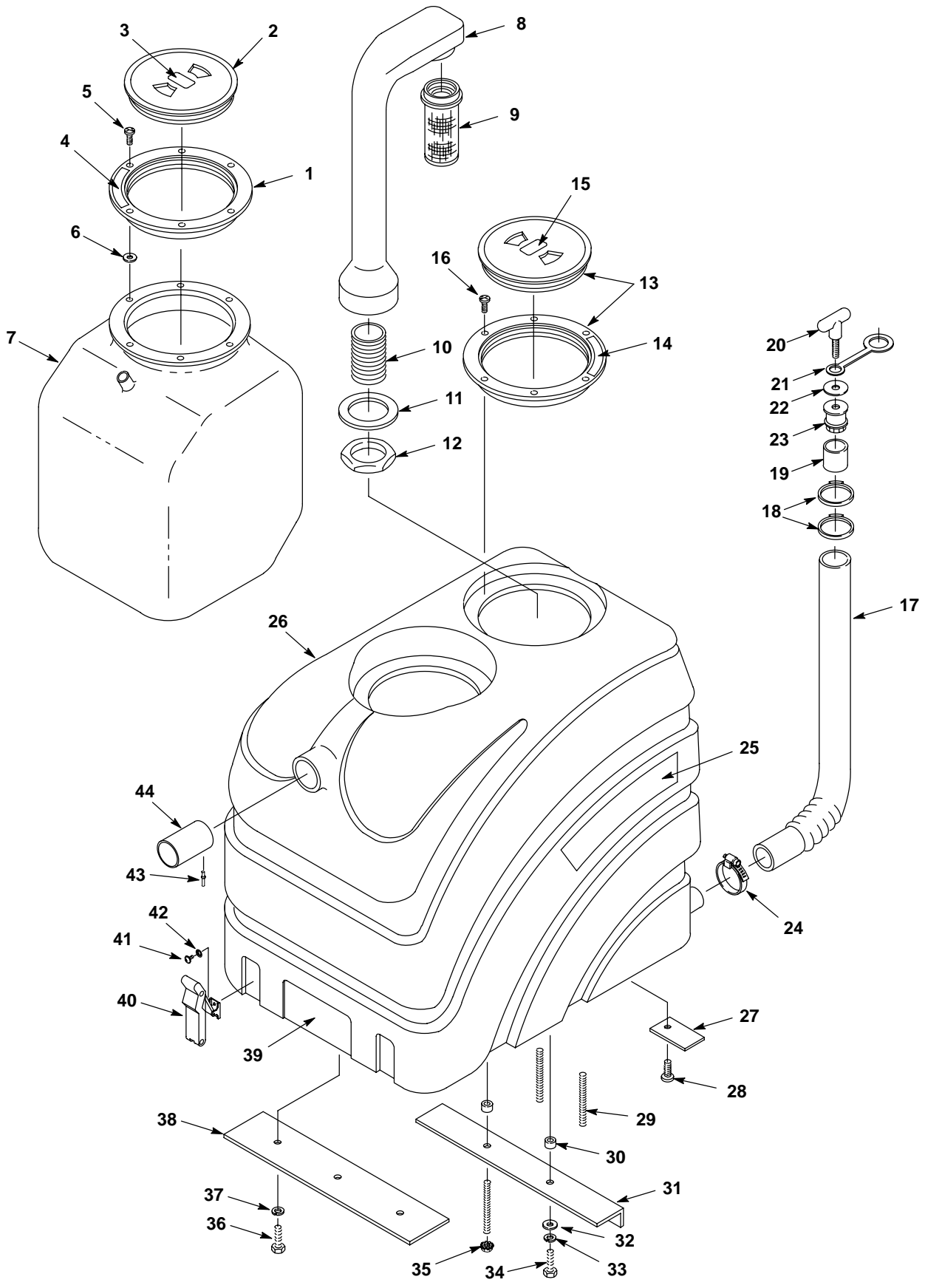

UPPER HOUSING GROUP

REF	PART #	DESCRIPTION	QTY.
▽	100103	CLEAR LID, W/CNTRS NK HOLES	1
▲1	100109	LID OUTER RING	1
▲2	100105	● LID, CENTER ONLY CLEAR	1
3	120190	DECAL, "USE BLEEDER HOSE"	1
4	120907	DECAL, "IMPORTANT..."	1
5	140900	SCREW, 10-24X3/4 TRSPHL	6
6	140000	WASHER, 1/4 FLT	6
7	602783	BLADDER	1
8	602448	STANDPIPE W/NIPPLE	1
9	180613	● FLOAT, SHUT-OFF	1
10	606088	FITTING 1-1/2" NIPPLE	1
11	101714	GASKET, WASTE AIR CHAMBER	1
12	210240	NUT, FLANGED METAL 1-1/2	1
13	100102	● CLEAR LID W/STANDARD HOLE	1
14	120907	DECAL, IMPORTANT-ALWAYS...	1
15	120906	DECAL, IMPORTANT-DRAIN...	1
16	140825	SCREW, #6X1/2 PANPHL	6
▽	590965	KIT, DRAIN HOSE COMPLETE	1
▲17	160627	HOSE, DRAIN	1
▲18	140072	CLAMP, 1 9/16 STEPLESS	2
▲19	140921	SLEEVE, DRAIN HOSE	1
▽▲	501061	● ASM DRAINHOSE STOPPER	1
▲20	230831	KNOB, DRAIN HOSE	1
▲21	230882	STRAP, DRAIN STOPPER	1

REF	PART #	DESCRIPTION	QTY.
▲22	140056	WASHER 3/8IDX1.50OD FNDR	1
▲23	140955	PLUG, DRAIN HOSE	1
24	140307	CLAMP, HOSE 3/4 TO 1-3/4	1
25	608220	DECAL, PX-1500HPH	2
26	101396	TANK, RECOVERY BLUE	1
27	230845	PLATE, CORD CLAMP	1
28	140834	SCREW 1/4-20X5/8 FLTPHL	1
29	140258	SCREW 1/4-20X4-1/4 STUD	3
30	140134	BUSHING .375ODX.250IDX.270THK	2
31	230846	BRACKET, TANK SUPPORT	1
32	140000	WASHER 1/4 FLT	1
33	140016	WASHER 1/4 LCK	1
34	140554	SCREW 1/4-20X3/4 HXHDCP	1
35	140524	NUT 1/4-20 KEP	1
36	140259	SCREW 1/4-20X5/8 HXHDCP	3
37	140016	WASHER 1/4 LCK	3
38	230946	BRACKET, TANK BRACE FRONT	1
39	120101	DECAL, "CASTEX" WHITE MEDIUM	1
40	140932	● LATCH, HOOD W/ KEEPER	2
41	140801	SCREW 8-32X3/8 TRSPHL	4
42	140023	WASHER #8 INT	4
43	140703	RIVET, POP 3/16 X .251-.375	1
44	230905	TUBE, INLET	1

▽ ASSEMBLY

▲ INCLUDED IN ASSEMBLY

● RECOMMENDED STOCK ITEMS

LOWER HOUSING GROUP

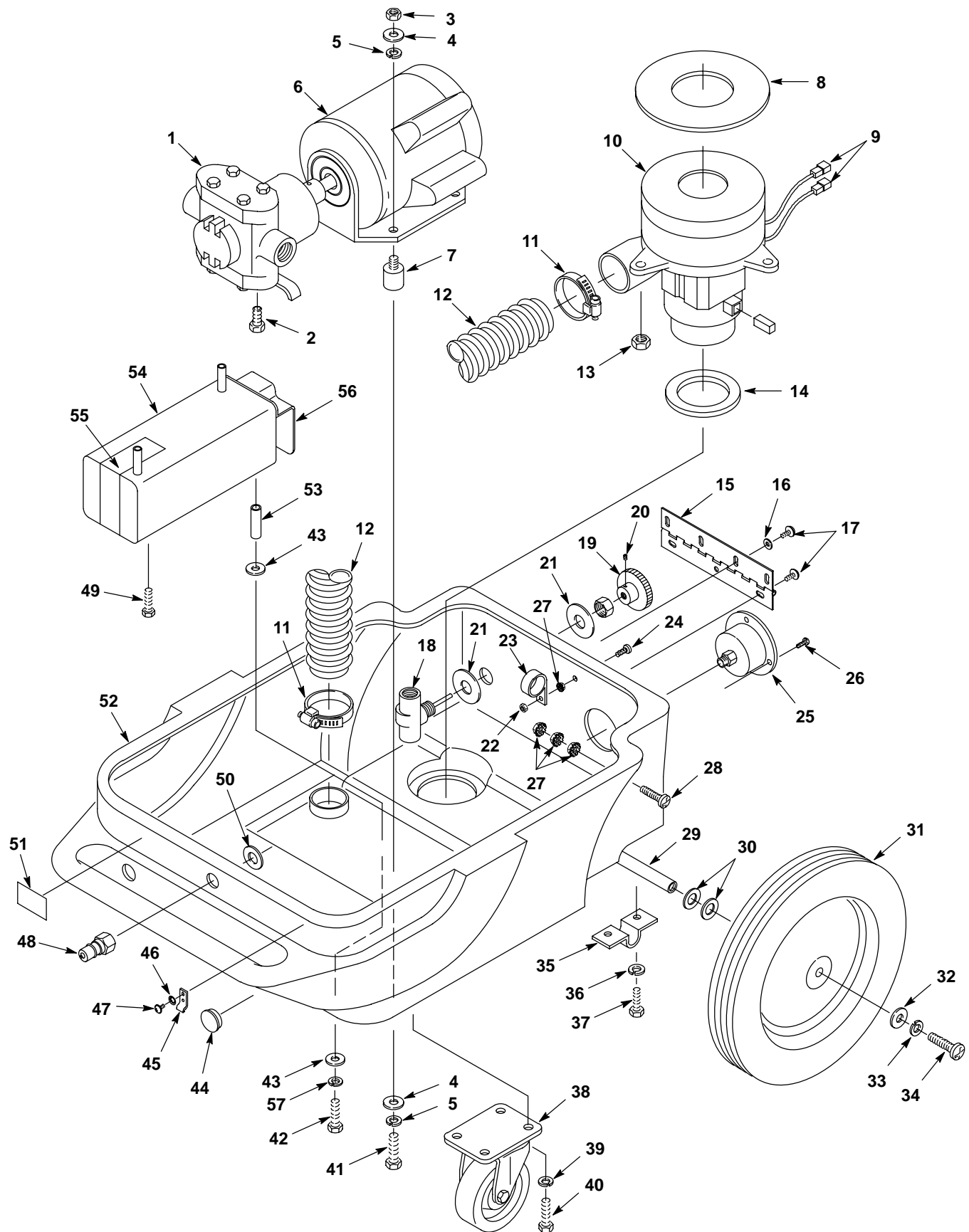

LOWER HOUSING GROUP

REF	PART #	DESCRIPTION	QTY.
1	180100	PUMP, TWIN PISTON	1
2	140823	SCREW 10-24X5/8 TRSPHL	2
3	140506	NUT 5/16-18 HEX	4
4	140027	WASHER 5/16 FLT	8
5	140015	WASHER 5/16 SPLTLCK	8
6	130450	MOTOR, PUMP DRIVE 1/3 HP (120V)	1
	130453	MOTOR, PUMP DRIVE (230V)	1
7	130031	MOUNT, MOTOR 1-1/4"	4
8	100001	●GASKET VAC MOTOR 7.2	1
9	130096	TERMINAL, ML DSCNT	2
∇10	130404	●MOTOR, VAC 7.2/3 STAGE (120V)	1
▲	190157	●BRUSH,CARBON 2/PK	2
∇	130405	MOTOR, VAC 7.2/3 STAGE (230V)	1
▲	190157	BRUSH,CARBON 2/PK	2
11	140308	CLAMP, HOSE 1-5/16 TO 2-1/4	2
12	160629	●HOSE 2" X 28" WHITE	1
13	140501	NUT, 1/4-20 NYLOCK	3
14	102567	●GASKET, VAC MOTOR INTAKE	1
15	230390	HINGE, TANK	1
16	140000	WASHER 1/4 FLT	4
17	140885	SCREW 1/4-20X1/2 TRSPHL	7
∇18	210108	VALVE, PRESSURE CONTROL	1
▲19	210023	KNOB, NEEDLE VALVE	1
20	140894	SCREW, SCST CPPT 10-32X1/4	1
21	27820	WASHER, FLAT .687 ID X 1.50 OD	2
22	140552	NUT 10-24 NYLCK	1
23	140328	CLAMP, 3/8" NYLON	1
24	140196	SCREW 10-24X1 TRSPHL	1
25	606659	GAUGE,PRESSURE 0-600 PSI	1
26	140825	SCREW #6X1/2 PANPHL	3
27	140519	NUT 10-24 KEP	4

REF	PART #	DESCRIPTION	QTY.
28	140196	SCREW 10-24X1 TRSPHL	1
29	230907	AXLE, 18"	1
30	140008	WASHER 1/2 FLT	4
31	103009	●WHEEL, 12" X 1.75 WHITE/GRAY	2
32	140000	WASHER 1/4 FLT	2
33	140016	WASHER 1/4 LCK	2
34	140885	SCREW 1/4-20X1/2 TRSPHL	2
35	230746	BRACKET AXLE OFFSET	2
36	140016	WASHER 1/4 LCK	4
37	140259	SCREW 1/4-20X5/8 HXHDCP	4
38	103065	●CASTER, SWIVEL 4"	2
39	140016	WASHER 1/4 LCK	8
40	140259	SCREW 1/4-20X5/8 HXHDCP	8
41	140223	SCREW 5/16-18X3/4 HXHDCP	4
42	140869	SCREW 10-24X1-3/4 PANPHL	2
43	140011	WASHER 3/16 FLT	4
44	130284	PLUG, DOME 1.00" BLACK	1
45	140932	KEEPER (PART OF LATCH)	2
46	140023	WASHER #8 INT	4
47	140801	SCREW 8-32X3/8 TRSPHL	4
48	150933	FITTING, 1/4F QD PLUG BRS SER60	1
49	140823	SCREW 10-24X5/8 TRSPHL	2
50	140058	WASHER .543X.875X.062 WAND	1
51	120123	DECAL, CAUTION PRESSURE	1
52	101397	CHASSIS, BLUE	1
53	140918	SPACER .20X.31X1.00	2
∇54	180440	HEATER, 1700W (120V) COMPLETE	1
	180441	HEATER 1700W (230V) COMPLETE	1
▲	102566	INSULATOR, HEATER	1
55	102568	STRAP, NYLON W/ ADHESIVE	1
56	101288	COVER HEATER	1

∇ ASSEMBLY

▲ INCLUDED IN ASSEMBLY

● RECOMMENDED STOCK ITEMS

PLUMBING GROUP

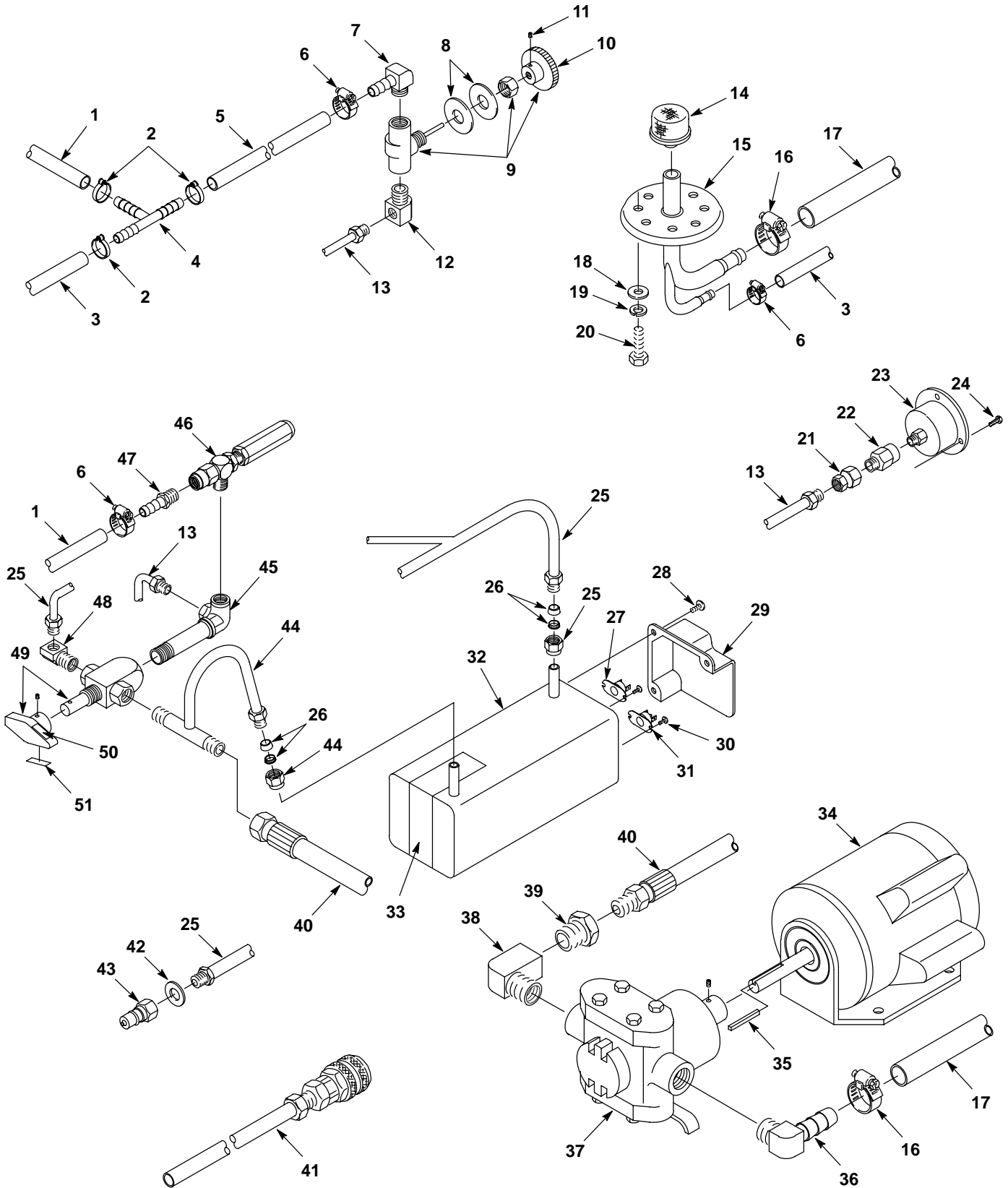

PLUMBING GROUP

REF	PART #	DESCRIPTION	QTY.
1	606359	HOSE 1/4ID X 8" GRAY L.P.	1
2	140325	CLAMP, EAR 1/2"	3
3	606161	HOSE 1/4 X 36" GRAY L.P.	1
4	150713	TEE, UNION 1/4" BARB NYLON	1
5	606244	HOSE 1/4IDX16" LP	1
6	140305	CLAMP, HOSE 7/32-5/8 DIAM	3
7	150418	FITTING, 1/4MX1/4H ELBOW 90 BRS	1
8	27820	WASHER, FLAT .687 ID X 1.50 OD	2
∇9	210108	●VALVE, PRESS CNTRL W/NUT	1
▲10	210023	●KNOB, NEEDLE VALVE	1
▲11	140894	●SCREW, SCST CPPT 10-32X1/4	1
12	606987	FITTING, 1/4"NPTM X 1/4"INV.FL	1
13	606666	ASM PRESSURE GAUGE TUBE	1
14	603186	●SCREEN CLEAN WATER TANK	1
15	600452	PLATE BLADDER ASM	1
16	140310	CLAMP, HOSE 5/16-7/8	2
17	603051	HOSE, 29"LONG REINFORCED	1
18	140000	WASHER 1/4 FLT	4
19	140016	WASHER 1/4 LCK	4
20	140259	SCREW 1/4-20X5/8 HXHDCP	4
21	606665	FITTING, GAUGE ADAPTER	1
22	606660	●FITTING, GAUGE SNUBBER	1
23	606659	●GAUGE, PRESSURE 0-600 PSI	1
24	140825	SCREW #6X1/2 PANPHL	3
25	606663	HEATER OUTLET TUBE W/NUT	1
26	600546	FERRULE S/S FOR #600545	2
27	130692	CONTROL, THERMOSTAT	1

REF	PART #	DESCRIPTION	QTY.
28	140197	SCREW 10-24X3/8 TRSPHL	2
29	101288	COVER HEATER	1
30	6032.6	SCREW 8-32X3/8 PANPHL	4
31	130693	LIMIT, THERMOSTAT	1
∇32	180440	●HEATER, 1700W (120V) CMPLT	1
	180441	HEATER, 1700W (230V) COMPLETE	1
▲	102566	INSULATOR, HEATER	1
33	102568	STRAP, NYLON W/ ADHESIVE	1
34	130450	●MOTOR, PUMP DRIVE (120V)	1
	130453	MOTOR, PUMP DRIVE (230V)	1
35	190310	●PUMP, SHAFT KEY 5300 SERIES	1
36	150431	FITTING 1/2MX1/2H ELBOW 90	1
37	180100	●PUMP, TWIN PISTON	1
38	150405	FITTING 1/2MX1/2F ELB STRT90	1
39	150101	FITTING 1/2MX1/4F BUSHING	1
40	160140	●HOSE, PULSE 36"	1
41	700141	●HOSE BLEEDER SERIES 60	1
42	140058	WASHER .543X.875X.062 WAND	1
43	150933	●FITTING 1/4F QD PLUG SER60	1
44	606664	HEATER INLET TUBE W/NUT	1
45	606662	MANIFOLD, PRESSURE RELIEF	1
46	210211	VALVE, PRESSURE RELIEF	1
47	150525	FITTING 1/8MX1/4H BARB	1
48	606987	FITTING, 1/4"NPTM X 1/4"INV.FL	1
49	210043	●VALVE, BALL 3-WAY 1/4" BRASS	1
50	120198	DECAL, CLEAN - VALVE KNOB	1
51	120199	DECAL, PREHEAT - VALVE KNOB	1

∇ ASSEMBLY

▲ INCLUDED IN ASSEMBLY

● RECOMMENDED STOCK ITEMS

SOLUTION PUMP GROUP

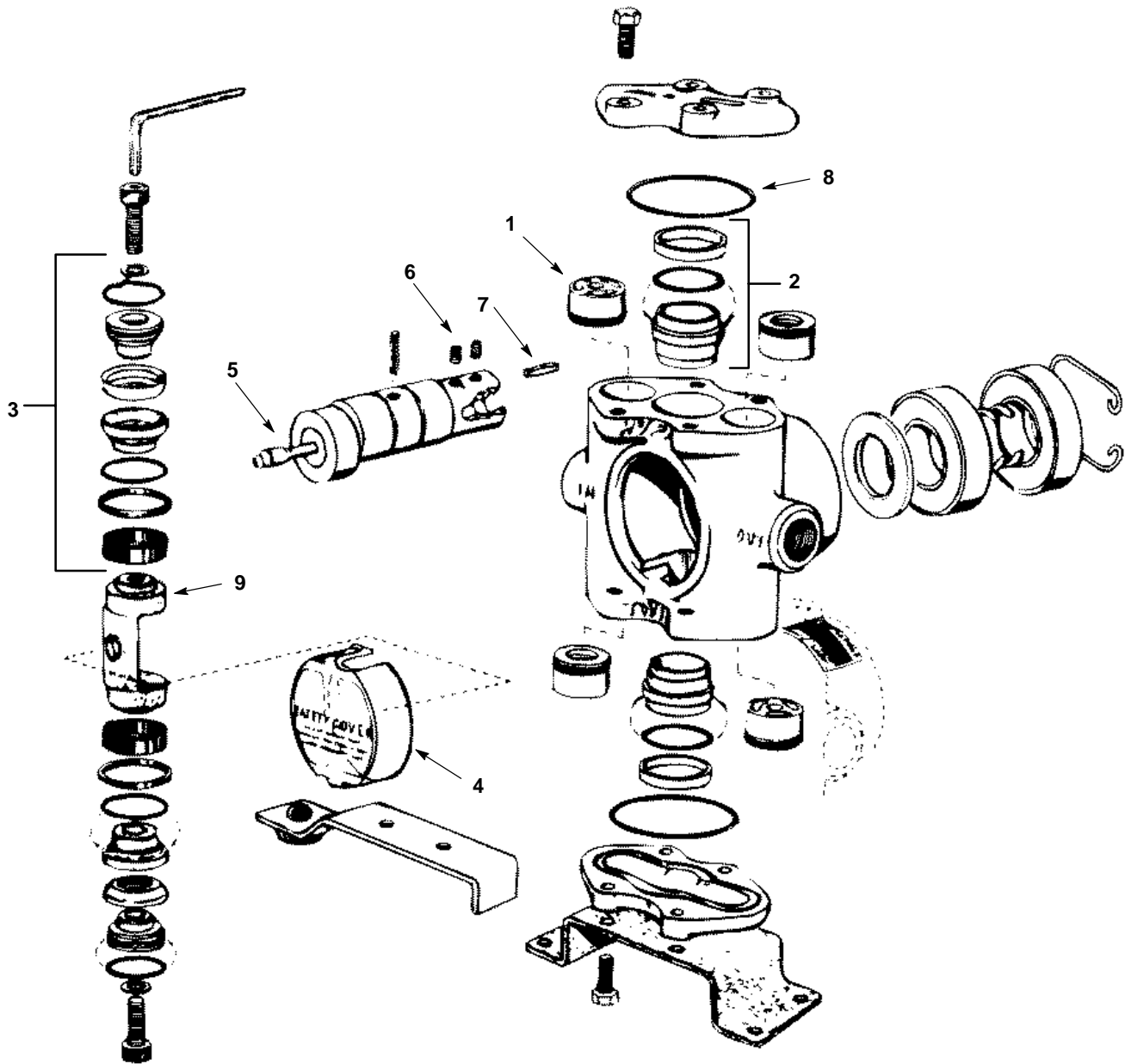

REF	PART #	DESCRIPTION	QTY.
	180100	PUMP, TWIN PISTON (COMPLETE)	1
1	190301	●VALVE KIT, SET OF 4	1
2	190302	●KIT, CYLINDER SLEEVE	1
3	190300	●CUP KIT, SET OF 2	1
4	190307	SAFETY COVER	1
5	190305	GREASE FITTING	1
6	190309	SET SCREWS, PUMP	2

REF	PART #	DESCRIPTION	QTY.
7	190310	●SHAFT KEY	1
8	190303	●KIT, O-RING (INCLUDES 2 O-RINGS)	1
9	190304	CONNECTING ROD	1
N/S	190316	●PULLER, VALVE SPRING RETAINER	1
N/S	190317	●PULLER, VALVE, POPPET SEAT	1
N/S	190022	●GUN, GREASE (METAL)	1

N/S= NOT SHOWN

127 mm (5 in) UPHOLSTERY TOOL ASSEMBLY

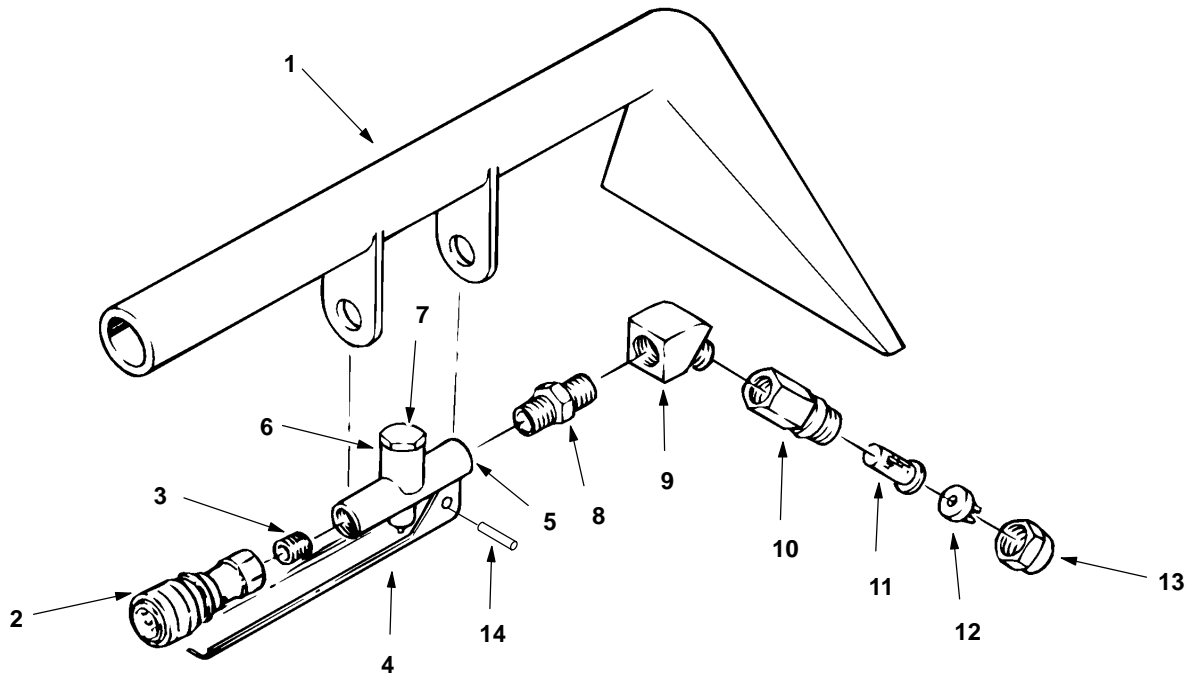

REF	PART #	DESCRIPTION	QTY.
	200505	TOOL, 5" HAND (COMPLETE)	1
1	200431.BK	TOOL, 5" HAND	1
2	150913	COUPLER, QUICK, SER. 60	1
3	150615	NIPPLE, CLOSE	1
4	200905	LEVER, K-VALVE W/PIN	1
5	210210	VALVE, FLOW CONTROL	1
6	190600	VALVE PIN & SPRING (NOT SHOWN)	1
7	210148	CAP, HEX, VALVE	1

REF	PART #	DESCRIPTION	QTY.
8	150606	NIPPLE, HEX 1/4"	1
9	150403	ELBOW, ST 1/4" 45°	1
10	200992	BODY, SPRAY 1/4"F	1
11	200996	SCREEN, SPRAY BODY	1
12	200965	TIP, BRASS #8002	1
13	200994	CAP, SPRAY BODY	1
14	140609	PIN, ROLL 3/16 X 9/16	1

N/S NOT SHOWN

OPTIONAL ACCESSORIES

HIGH PRESSURE FLOOR TOOL ASSEMBLY

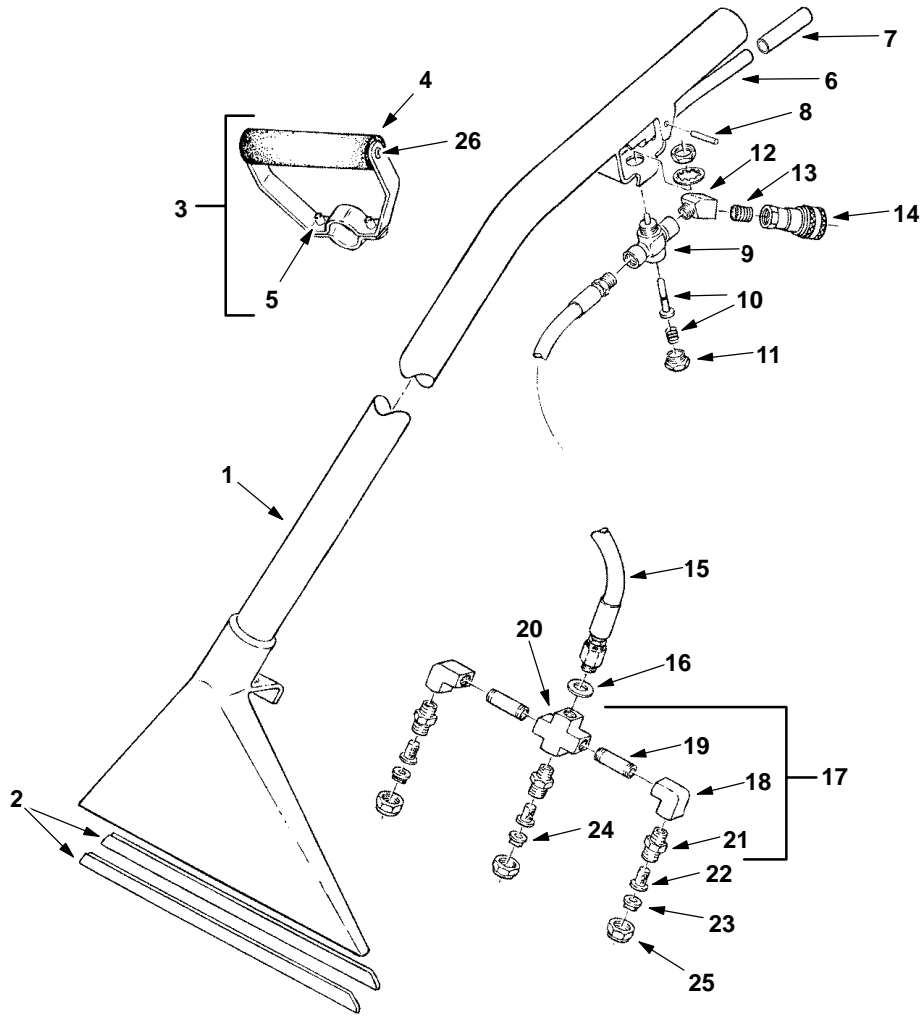

REF	PART #	DESCRIPTION	QTY.
	600049	TOOL, 13" FLOOR (COMPLETE)	1
1	200403.BK	TOOL, 13" FLOOR	1
2	200939	SHOES, FLOOR TOOL	2
3	200927	GRIP, ADJUSTABLE COMPLETE	1
4	200912	FOAM, GRIP	1
5	140259	SCREW, 1/4 X 5/8	2
6	200902	TRIGGER, FLOOR TOOL	1
7	200809	SLEEVE, TRIGGER	1
8	140605	PIN	1
	140520	NUT, PUSH	2
9	210150	VALVE, FLOW CONTROL	1
10	190603	KIT, VALVE PIN & SPRING	1
11	N/A	CAP, HEX, VALVE	1
12	150403	ELBOW, 1/4-45°	1
13	150615	NIPPLE, CLOSE 1/4	1

REF	PART #	DESCRIPTION	QTY.
14	150913	COUPLER, QUICK SER. 60	1
15	160175	HOSE, SOLUTION HP	1
16	140058	WASHER	1
▽17	700062	ASM., SPRAY BAR	1
▲18	150401	ELBOW, 90° 1/4F X 1/4F	2
▲19	150600	NIPPLE	2
▲20	150700	CROSS	1
▲21	200993	SPRAY BODY	3
22	200996	SCREEN, SPRAY BODY	3
23	200986	TIP, SPRAY (#9502)	2
24	200988	TIP, SPRAY (#11002)	1
25	200994	CAP, SPRAY BODY	3
26	140834	SCREW, 1/4-20 X 5/8	2
N/S	120845	DECAL, "HIGH PRESSURE"	1

▽ ASSEMBLY

▲ INCLUDED IN ASSEMBLY

N/S NOT SHOWN

SOLUTION AND VACUUM HOSES

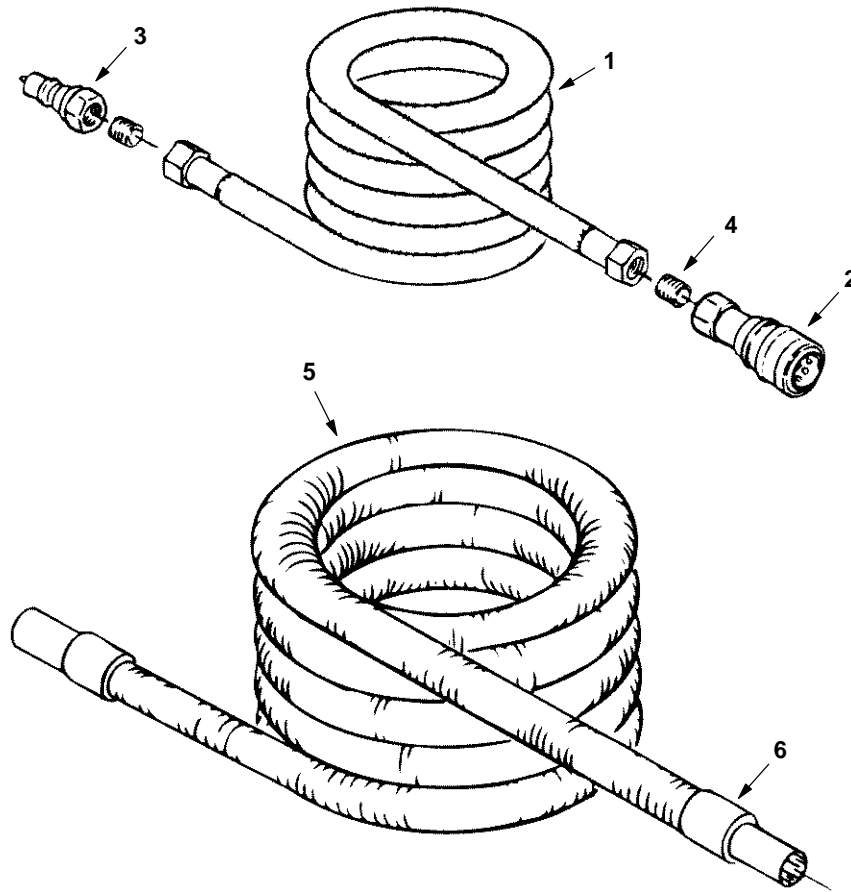

REF	PART #	DESCRIPTION	QTY.
▽1	160191	SOLUTION HOSE 25'	1
▲2	150913	COUPLER, QUICK SER. 60	1
▲3	150933	PLUG, QUICK COUPLER	1
▲4	150615	NIPPLE	2
▽5	160401	HOSE, VACUUM W/ CUFFS 25'	1
▲6	160430	CUFF, HOSE 1-1/2"	2
N/S	160451	CONNECTOR, VAC HOSE 1-1/2"	1

▽ ASSEMBLY

▲ INCLUDED IN ASSEMBLY

N/S NOT SHOWN