

Castex®

PX-2

Compact Carpet and Upholstery Extractor
Extractor Compacto Para Alfombras y Tapicería

Model No.:

607441

607423 – (includes cart)

608213 – (includes cart/chemicals)

Operator and Parts Manual

Manual del Operador y Piezas

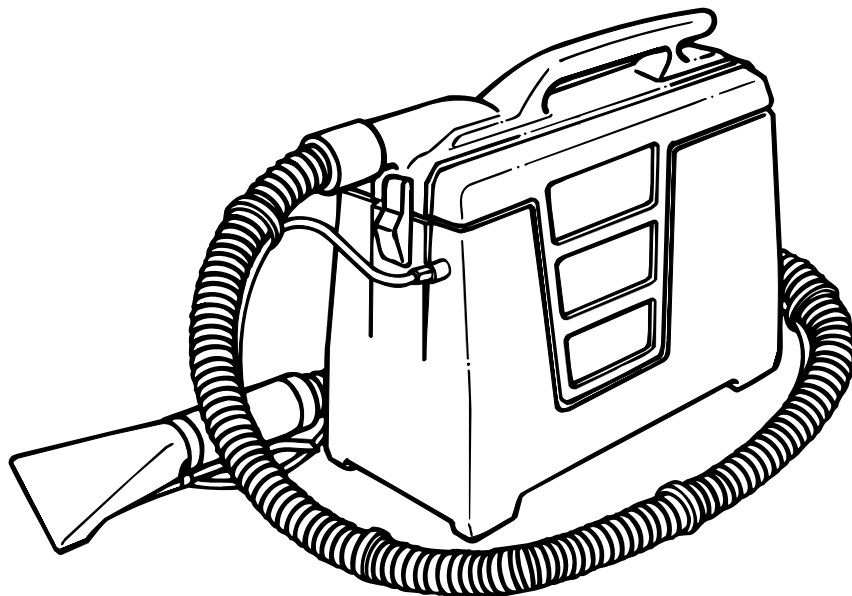

CASTEX
12875 RANSOM STREET
HOLLAND MI 49424 U.S.A.

FAX: 1-800-678-4240
CUSTOMER SERVICE: 1-800-964-9644

608046
Rev. 02 (10-01)

120V 50/60HZ

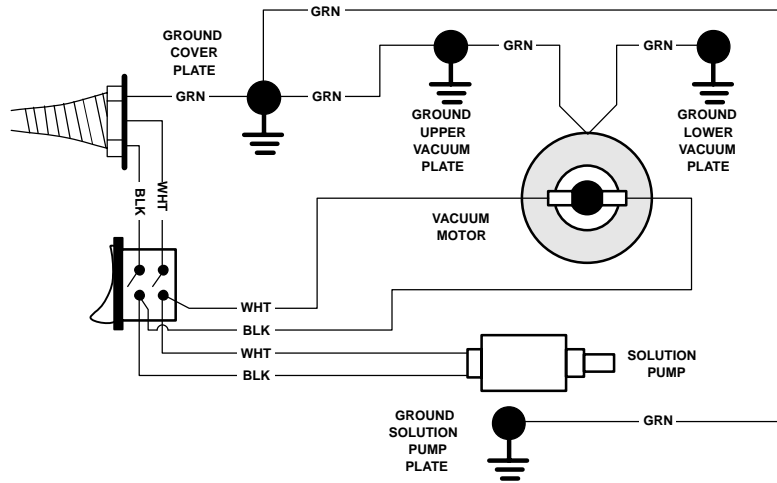

230V/240V

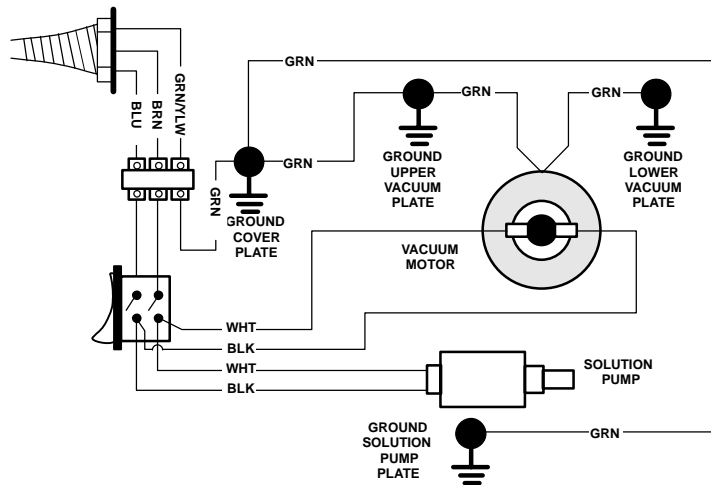

120V – 400Hz

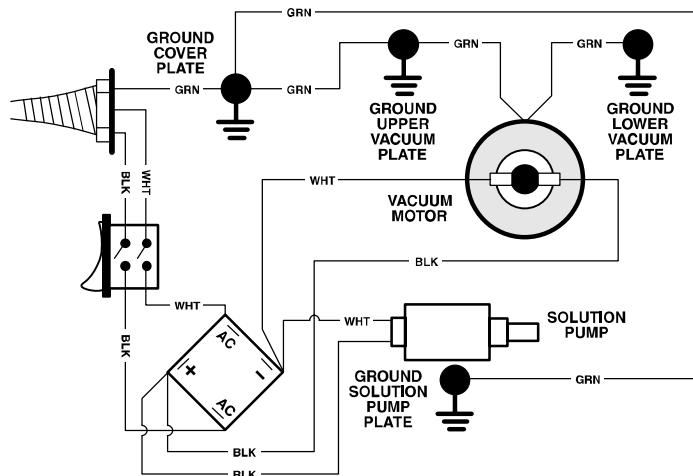

MACHINE PARTS
PIEZAS DE LA MÁQUINA

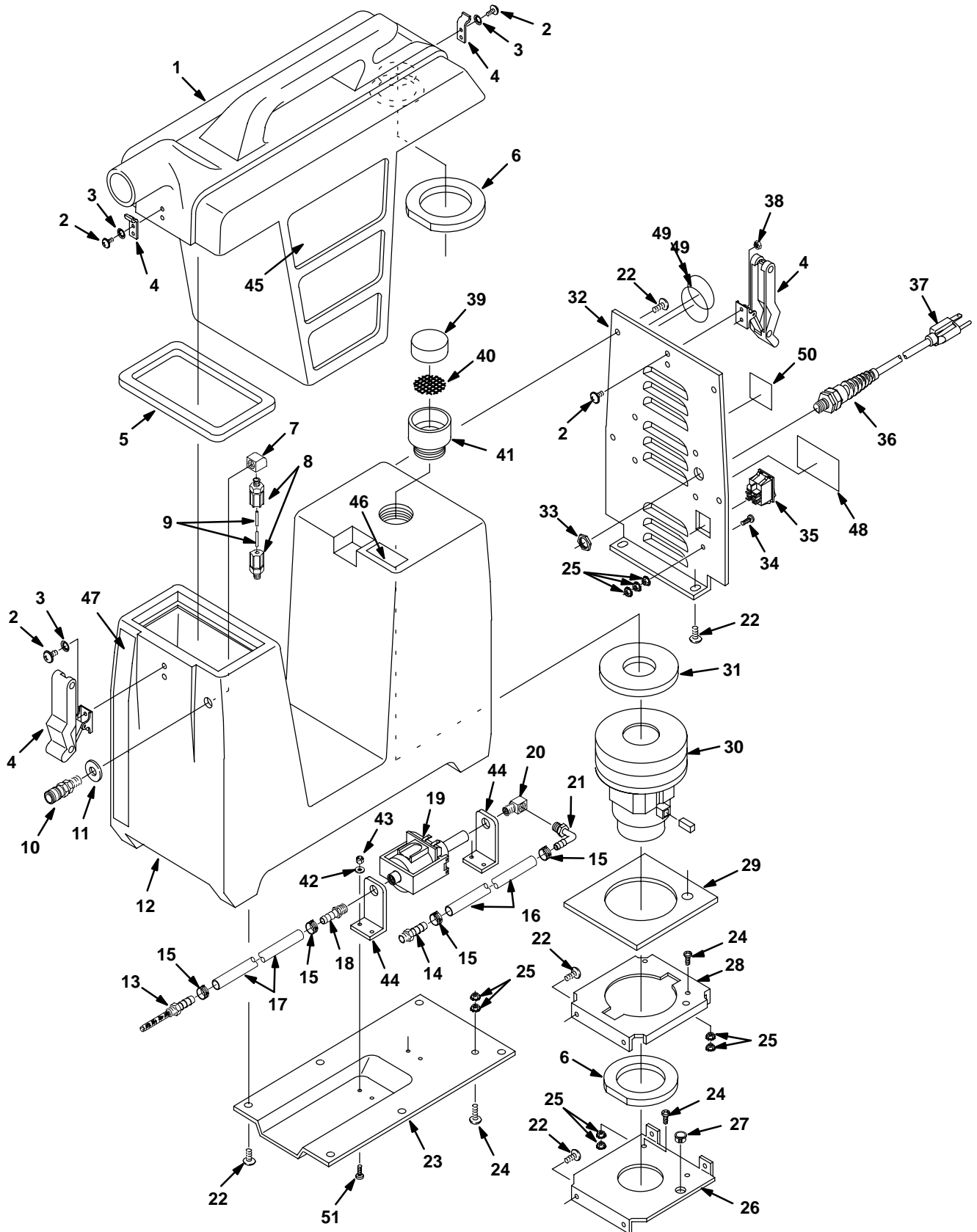

MACHINE PARTS
LISTA DE PIEZAS DE LA MÁQUINA

REF	PART #	DESCRIPTION	QTY.
1	608031	TANK , RECOVERY, BLUE	1
2	140801	SCREW, MCH 8-32X3/8	8
3	140023	WASHER, INT LCK TOOTH #8	6
4	140932	●LATCH, HOOD RUBBER	2
5	102553	●GASKET, SOLUTION TANK SEAL	1
6	102556	●GASKET, RECOVERY TANK SEAL	2
7	150402	ELBOW, 90° 1/8F X 1/8F	1
8	150309	CONNECTOR MALE 1/8NPT W/NUT	2
9	560495	TUBING, NYLON .17ID X 12"	1
10	150915	COUPLER, QCK 1/8 BRASS-SER 5	1
11	140036	WASHER, FLAT 3/8	1
12	608029	TANK, SOLUTION, BLUE	1
13	603650	FILTER, SOLUTION TANK	1
14	603649	ADAPTER FITTING 1/4HBX1/4H	1
15	603654	CLAMP, HOSE CTB	4
16	603651	HOSE, 1/4"ID X 5-1/4"	1
17	603652	HOSE, 1/4"ID X 10-1/2"	1
18	150525	FITTING, 1/8M X 1/4H	1
19	603653	●PUMP, SOLUTION 120V 60HZ	1
	604238	PUMP, FLOJET 230V 50HZ	1
20	150407	ELBOW, 1/8M X 1/8F	1
21	578214000	ELBOW, 1/8M X 1/4 H 90° NYLON	1
22	140197	SCREW, 10-24X3/8	14
23	608513	PANEL, BOTTOM, BLACK	1
24	140892	SCREW, MCH 10-24X1/2	3
25	140519	NUT, KEP 10-24 - S/S BULK	9
26	230776	PLATE, BAFFLE	1
27	130698	BUSHING, SNAP	1
28	230777	PLATE VAC MOTOR MOUNT	1
29	102552	●GASKET, VAC MOTOR PLATE	1

REF	PART #	DESCRIPTION	QTY.
30	130457	●MOTOR, VAC 4.8-2 STAGE - 120V	1
	190155	●- CARBON BRUSH RPLMT (2/PK)	2
	130458	MOTOR, VAC 4.8-2 STAGE - 230V	1
	190158	- CARBON BRUSH RPLMT (2/PK)	2
31	102557	●GASKET, VAC MOTOR SEAL	1
32	608514	PANEL REAR COVER, BLACK	1
33	140549	NUT, LOCK 3/8 CONDUIT	1
34	140895	SCREW, MCH 10-24X3/4	1
35	602669	●SWITCH, DPST SYMBOL 120V & 230V	1
36	130167	●CORD GRIP LIQ.TITE 1/2n (120V)	1
	130190	●CORD GRIP LIQ.TITE FLEX 3/8 NPT (230V)	1
37	130277	●CORD, 18/3 X 25' YLW - 120V	1
	600397	●CORD, 18/3 X 7.6 M BLACK - 230V	1
38	28990	NUT, LOCK 8-32 W/NYL INST	2
39	102550	●FILTER, VACUUM	1
40	230794	●SCREEN FILTER	1
41	230836	ADAPTER, MALE 1-1/2X1-1/4 PVC	1
42	140011	WASHER, #10 FLAT	4
43	140552	NUT, NYLON 10-24	4
44	603663	BRACKET, PUMP MOUNT	2
45	606085	DECAL, CASTEX ANSER	2
46	120906	DECAL, "IMPORTANT DRAIN..."	1
47	121006	DECAL, GALLON/LITER MARK	1
48	120660	DECAL, WARNING EXTRACTOR	1
49	120099	DECAL, PREVENTATIVE (120V)	1
50	578729	DECAL, "READ MANUAL"	1
51	140892	SCREW 10-24X1/2	4

● RECOMMENDED STOCK ITEMS / ARTICULOS RECOMENDADOS

**STANDARD HAND TOOL
ACCESORIO ESTÁNDAR DE MANO**

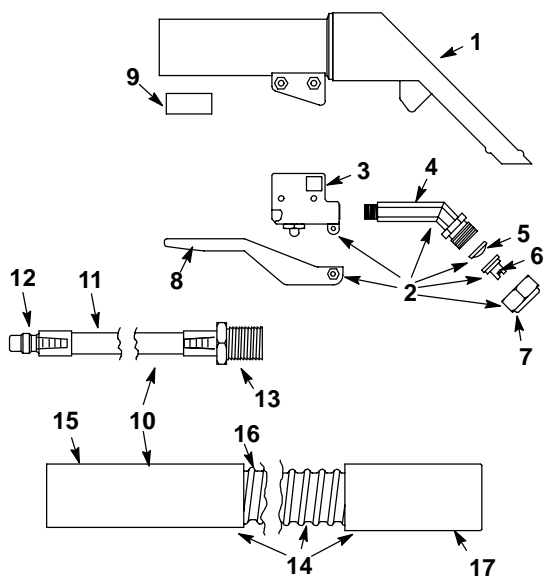

REF	PART #	DESCRIPTION	QTY.
	609349	●TOOL, HAND COMPLETE WITH HOSE	1
▽	608901	●TOOL, HAND W/ TRIGGER ASM.	1
▲ 1	608891	●TOOL, HAND	1
▲▽ 2	608899	ASM., TRIGGER	1
▲ 3	608894	BODY, VALVE	1
▲ 4	608895	NOZZLE, SPRAY	1
▲ 5	608900	●SCREEN	1
▲ 6	608896	●TIP, SPRAY	1
▲ 7	608897	●CAP	1
▲ 8	608898	TRIGGER	1
9	608892	SEAL, SOLUTION HOSE	1
▽ 10	611128	ASM., HOSE VACUUM/SOLUTION	1
▲ 11	160499	HOSE, SOLUTION	1
▲ 12	150921	PLUG, QCK. COUPLER – SER. 5	1
▲ 13	150111	ADAPTER, 1/8M X 1/4F – BRASS	1
▲▽ 14	608905	ASM., VACUUM HOSE	1
▲ 15	609428	CUFF, HOSE 1.5 X 5.25	1
▲ 16	608903	HOSE, VACUUM 1.5	1
▲ 17	609440	CUFF, HOSE 1.5 X 3.5	1

▽ ASSEMBLY / CONJUNTO

▲ INCLUDED IN ASSEMBLY / INCLUIDO EN EL CONJUNTO

● RECOMMENDED STOCK ITEMS / ARTICULOS RECOMENDADOS

**OPTIONAL FLOOR TOOL
ACCESORIO OPCIONAL DE PISO**

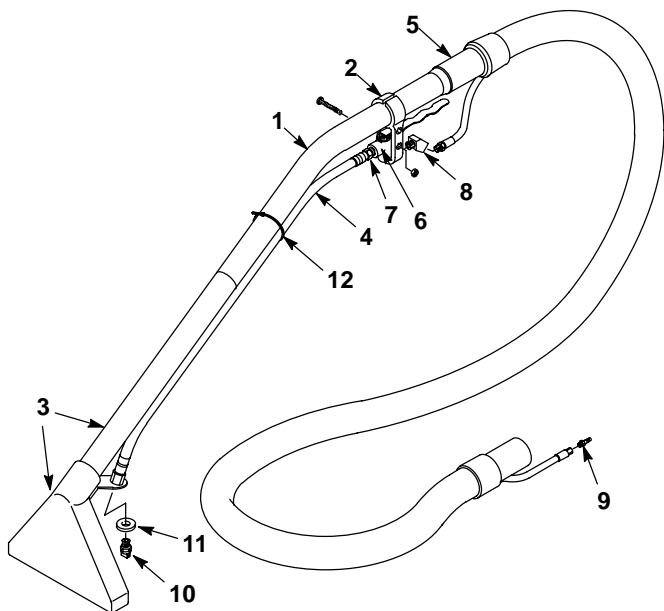

REF	PART #	DESCRIPTION	QTY.
▽	605976	TOOL, FLOOR SPOTTER COMPLETE	1
▲ 1	200467	WAND, UPPER SECTION ONLY	1
▲ 2	605988	ASM., VALVE HANGER	1
▲ 3	605977	ASM., 8" HEAD AND LOWER TUBE	1
▲ 4	605991	ASM, 1/4" HOSE WHIP 3 FT	1
▲ 5	603546	HIDE A HOSE 10FT	1
▲ 6	578064000	●VALVE	1
▲ 7	150516	FITTING, 1/4MX3/8H BARB BRS	1
▲ 8	150403	FITTING, 1/4MX1/4F ELBOW STRT45	1
▲ 9	150921	PLUG, QCK. COUPLER – SER. 5	1
▲ 10	605989	VEE JET, PLASTIC	1
▲ 11	605990	WASHER, ABS, 0.53"X1.1"X0.19"TH	1
▲ 12	130041	TIE, CABLE	1

▽ ASSEMBLY / CONJUNTO

▲ INCLUDED IN ASSEMBLY / INCLUIDO EN EL CONJUNTO

● RECOMMENDED STOCK ITEMS / ARTICULOS RECOMENDADOS

**OPTIONAL HANDCART
CARRITO TRANSPORTADOR OPCIONAL**

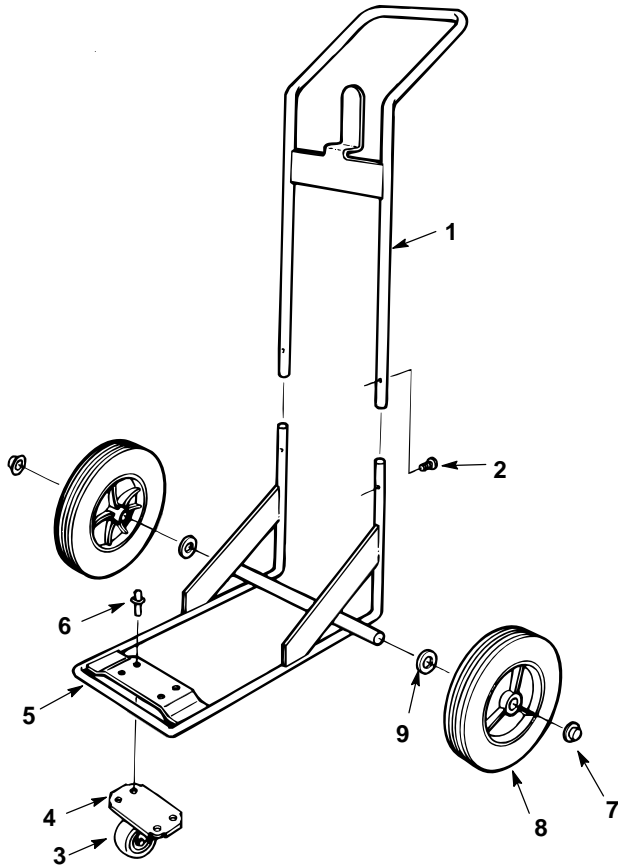

REF	PART #	DESCRIPTION	QTY.
▽	701015	CART, HAND COMPLETE	1
▲ 1	230781.BK	HANDLE, WELDMENT CART	1
▲ 2	140890	SCREW, MCH 10-24 X 1/2" TRSPHL - S/S	2
▲ 3	140000	WASHER, FLAT 1/4" USS -ZINC	4
▲ 4	103001	CASTER, SWIVEL - 3"	1
▲ 5	230780.BK	FRAME, WELDMENT CART	1
▲ 6	140701	RIVET, POP 1/4 X .126-.250 STEEL	4
▲ 7	103019	CAP, HUB	2
▲ 8	607277	WHEEL, 8" X 1.75 SMOOTH GRAY	2
▲ 9	140008	WASHER, FLAT .5/510 X 1.25 X .06 S/S	2

▽ ASSEMBLY / CONJUNTO

▲ INCLUDED IN ASSEMBLY / INCLUIDO EN EL CONJUNTO

**OPTIONAL SPOTTING KIT
JUEGO OPCIONAL QUITAMANCHAS**

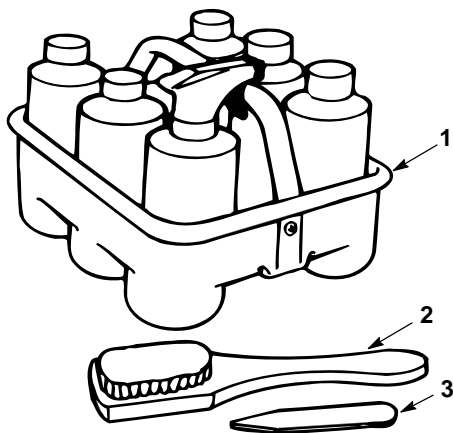

REF	PART #	DESCRIPTION	QTY.
▽	111002	KIT, SPOTTING	1
▲ 1	701165	ASM., BASKET	6
▲ 2	240042	FURNITURE BRUSH	1
▲ 3	240049	SCRAPER	1

▽ ASSEMBLY / CONJUNTO

▲ INCLUDED IN ASSEMBLY / INCLUIDO EN EL CONJUNTO

CLEANING SOLUTION PACKETS

REF	PART #	DESCRIPTION	QTY.
N/S	112012	PACKETS, CLEANING SOLUTION 2 OZ (50/CASE)	1