

# Castex®

## SCX-350

Self-Contained Carpet Extractor

**Model No.:**  
**607439**

**Operator and Parts Manual**

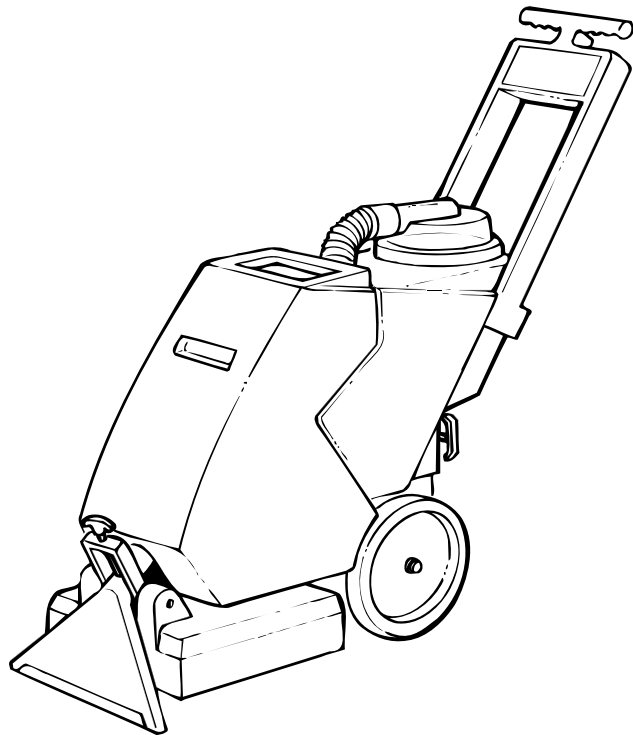

**CASTEX INCORPORATED**  
12875 RANSOM STREET  
HOLLAND MI 49424 U.S.A.

A TENNANT COMPANY

1-800-522-7839  
616-786-2330  
FAX: 1-800-678-4240  
CUSTOMER SERVICE: 1-800-964-9644

**608042**  
**Rev. 00 (07-99)**

# OPERATION

---

This manual is furnished with each new model. It provides necessary operation and maintenance instructions.

**Read this manual completely and understand the machine before operating or servicing it.**

When ordering replacement parts, use the illustrated Parts Lists in this manual. Before ordering parts or supplies, be sure to have your machine model number and serial number handy. Parts and supplies may be ordered by phone or mail from any Authorized Service Center or Distributor.

This machine will provide excellent service. However, the best results will be obtained at minimum costs if:

- The machine is operated with reasonable care.
- The machine is maintained regularly – per the maintenance instructions provided.
- The machine is maintained with manufacturer supplied or equivalent parts.

---

## MACHINE DATA

---

Please fill out at time of installation for future reference.

Model No.- \_\_\_\_\_

Install. Date - \_\_\_\_\_

Serial No.- \_\_\_\_\_

©2000 Tennant Company

Printed in U.S.A.

---

## TABLE OF CONTENTS

---

|  |    |
|--|----|
| <b>SAFETY PRECAUTIONS</b> .....          | 3  |
| <b>MACHINE SETUP AND OPERATION</b> ..... | 4  |
| <b>UPHOLSTERY CLEANING</b> .....         | 5  |
| <b>MACHINE MAINTENANCE</b> .....         | 5  |
| <b>RECOMMENDED STOCK ITEMS</b> .....     | 5  |
| <b>TROUBLE SHOOTING</b> .....            | 6  |
| <b>ELECTRICAL DIAGRAM</b> .....          | 7  |
| <b>PARTS LIST</b> .....                  | 8  |
| <b>OPTIONS</b> .....                     | 14 |

## SAFETY PRECAUTIONS

This machine is suited to clean carpets in an indoor environment and is not constructed for any other use. Use only recommended cleaning agents.

All operators must read, understand and practice the following safety precautions.

The following safety alert symbols are used throughout this manual as indicated in their description:

**⚠ WARNING: To warn of hazards or unsafe practices which could result in severe personal injury or death.**

**FOR SAFETY: To identify actions which must be followed for safe operation of equipment.**

The following information signals potentially dangerous conditions to the operator or equipment:

### FOR SAFETY:

1. **Do not operate machine:**
  - Unless trained and authorized.
  - Unless operator manual is read and understood.
  - In flammable or explosive areas unless designed for use in those areas.
  - Unless cord is properly grounded.
  - With damaged cord or plug.
  - If not in proper operating condition.
  - In outdoor areas.
  - In standing water.
  - With the use of an extension cord.
2. **Before operating machine:**
  - Make sure all safety devices are in place and operate properly.
3. **When using machine:**
  - Do not run machine over cord.
  - Do not pull machine by plug or cord.
  - Do not pull cord around sharp edges or corners.
  - Do not unplug by pulling on cord.
  - Do not stretch cord.
  - Do not handle plug with wet hands.
  - Keep cord away from heated surfaces.
  - Report machine damage or faulty operation immediately.
  - Follow mixing and handling instructions on chemical containers.

4. **Before leaving or servicing machine:**
  - Turn off machine.
  - Unplug cord from wall outlet.
5. **When servicing machine:**
  - Unplug cord from wall outlet.
  - Avoid moving parts. Do not wear loose jackets, shirts, or sleeves.
  - Use manufacturer supplied or approved replacement parts.

**⚠ WARNING: Hazardous Voltage. Shock or electrocution can result. Always unplug machine before servicing.**

**⚠ WARNING: Flammable materials can cause an explosion or fire. Do not use flammable materials in tank(s).**

**⚠ WARNING: Flammable materials or reactive metals can cause an explosion or fire. Do not pick up.**

## GROUNDING INSTRUCTIONS

Machine must be grounded. If it should malfunction or breakdown, grounding provides a path of least resistance for electrical current to reduce the risk of electrical shock. This machine is equipped with a cord having an equipment-grounding conductor and grounding plug. The plug must be plugged into an appropriate outlet that is properly installed in accordance with all local codes and ordinances. Do not remove ground pin; if missing, replace plug before use.

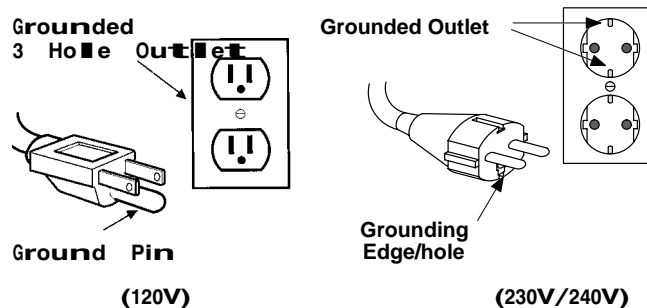

# OPERATION

## MACHINE SETUP AND OPERATION

**FOR SAFETY: Do not operate machine unless operator manual is read and understood.**

1. Pour 89–177 ml (3– 6 oz) of a recommended liquid cleaning agent into the solution tank located at front of machine.

**FOR SAFETY: When using machine, follow mixing and handling instructions on chemical containers.**

2. Using a clean bucket, fill solution tank with hot water, 60 °C (140 °F) max. Fill to the “DO NOT FILL PAST THIS LINE” decal on the front of the tank. If powdered cleaning chemicals are used, mix the powders in the filling bucket. **DO NOT MIX POWDERED CHEMICALS IN THE SOLUTION TANK!** This can plug the pumping system with undissolved powder.

**⚠ WARNING: Flammable materials can cause an explosion or fire. Do not use flammable materials in tank(s).**

**NOTE:** Use a clean bucket to fill the machine. Empty dirty water into another bucket. Always be certain to use separate buckets to fill and empty the machine. Perfectly clean water must be in the solution tank to avoid clogging the pumping system.

3. Plug the power cord into a grounded outlet (Figure 1).

**FOR SAFETY: Do not use machine unless cord is properly grounded.**

**FOR SAFETY: Do not use machine with the use of an extension cord.**

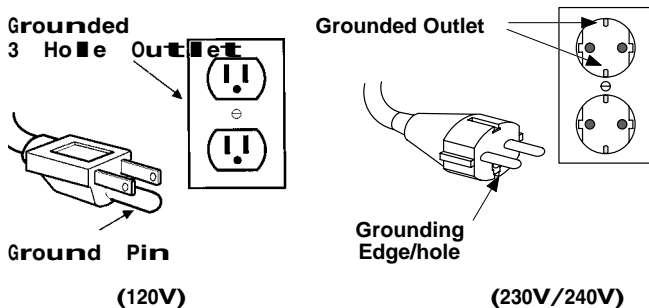

FIG. 1

4. Turn the height adjustment knob to raise or lower the brush to your carpet type as shown on the height adjustment decal.

5. Turn on the MASTER Switch.
6. Position the machine at the first area to be cleaned. Press and hold the CARPET CLEANING button. This sprays solution on the carpet and activates the brush. Pull the machine toward you about 1.2 M (4 ft) while lifting the handle lightly to form a tight vacuum seal on the carpet for best water recovery.

**⚠ WARNING: Flammable materials or reactive metals can cause an explosion or fire. Do not pick up.**

**NOTE:** You can scrub stains with brush only and no spray to prevent overwetting the carpet. Turn off the MASTER switch and press the CARPET CLEANING button.

7. Release the CARPET CLEANING button to stop spray, but continue to pull the machine toward you for another foot. Then, push down on the handle and roll the machine forward to the next strip, overlapping about 48 mm (2 in).

**NOTE:** If the brush stops during carpet cleaning, UNPLUG THE MACHINE, remove any clogging debris wrapped around the brush, then push in the BRUSH RESET Button located under the switchbox.

While cleaning, periodically check the recovery tank for foam buildup. If foam does appear, pull the vacuum hose out of the recovery dome, then pour about 30 ml (2 Tbs) of defoamer into the dome opening with the vacuum motor running to draw defoamer into the tank.

**ATTENTION: Foam or water will damage the vacuum motor. Always prevent foam or water from entering the standpipe screen by using defoamer. Damage due to foam or water is NOT COVERED BY WARRANTY.**

8. When the recovery tank is full, as shown by the FULL LINE decal on the side of the recovery tank, place a bucket under the drain valve downspout and pull the T-handle to empty the dirty water. Use a separate bucket for filling and emptying.
9. When you have finished your cleaning job, drain the recovery tank, then rinse it thoroughly to prevent odor buildup inside the tank.

## UPHOLSTERY CLEANING

Optional accessories are required for upholstery cleaning (See page 14).

This machine cleans most synthetic upholstery very well. Fabrics like Herculon and synthetic velvets will clean with excellent results. *Extraction is not recommended for most cottons, silks, wools or natural fiber velvets.* Check the cleaning instructions sewn in the furniture by the manufacturer for further instructions. Extra caution should be taken with furniture that has been re-upholstered. Any material under the new upholstery may bleed and discolor the new fabric.

1. Vacuum the upholstery before cleaning.
2. **TEST THE FABRIC FOR COLORFASTNESS.** Pour a small amount of cleaning solution on a white cloth. Hold the damp portion of the cloth against an area of upholstery which is hidden from view. Hold it there for 60 seconds. If no color transfers to the cloth, it should be safe to clean. However, always clean at your own discretion.
3. Remove the short vacuum hose from the recovery dome.
4. Connect the accessory vacuum hose to the recovery dome and to the hand tool.
5. Connect the solution hose to the upholstery connection, located above left wheel, and to the hand tool.
6. Turn on the MASTER switch.
7. Clean with the hand tool using as little cleaning solution as possible. Overlap your strokes to avoid streaking. Go over clean areas using only the vacuum to get fabric as dry as possible.
8. When you are finished, turn off the MASTER switch, drain the recovery tank, and disconnect the vacuum and solution hoses.

**ATTENTION: Relieve pressure *before* disconnecting hose by squeezing Hand Tool trigger for five seconds AFTER turning off MASTER switch.**

9. Rinse the recovery tank and the recovery dome thoroughly to prevent odor buildup inside the tank.

## MACHINE MAINTENANCE

For ease of servicing, the tanks are hinged to pivot open from the metal base frame. To open the machine for servicing follow these steps:

**FOR SAFETY: When servicing machine, unplug cord from wall outlet.**

- a. Remove the two hex-head screws under the chassis using a 7/16 wrench.
- b. Remove the two allen head screws holding the height adjustment bracket to the power brush. Use a 3/16 allen wrench.
- c. Lift the tanks upward, away from the metal chassis. (The vacuum tool will pivot upward with the tanks).

To keep your machine in top condition, perform these preventive steps at the intervals indicated.

1. Thoroughly rinse the recovery tank, the recovery dome and the brush after every use.
2. Clean the solution tank filters and standpipe screen after every use.
3. Every forty hours of operation, run a quality acetic acid solution through the pump system to dissolve normal alkaline chemical buildup. Mix .5 L (2 cups) of the acetic acid solution in the solution tank with two gallons hot water, 60 °C (140 °F) maximum. Hold a bucket under the spray jets to catch the spray, turn on the MASTER switch, and push the CARPET CLEANING button until the acetic acid solution begins to spray through the jets. Allow the solution to remain in the system overnight in *above freezing* temperatures. Later, drain the solution, then run 11 L (3 gal) of solution through the system to flush out impurities.

**FOR SAFETY: When using machine, follow mixing and handling instructions on chemical containers.**

**ATTENTION: DO NOT ALLOW THE EXTRACTOR TO FREEZE WITH WATER IN THE PUMPING SYSTEM.** This can crack the pump and *damage is not covered by warranty.* To avoid pump damage, always run the pump dry before exposing the extractor to freezing temperatures.

## RECOMMENDED STOCK ITEMS

Refer to Parts List section for recommended stock items. Stock Items are clearly identified with a bullet preceding the parts description. See example below:

| Ref. | Part No. | Description    | Qty. |
|------|----------|----------------|------|
| 1    | 201183   | 4M_STANDPIPE   | 1    |
| 2    | 188513   | •FILTR; BRUOFF | 1    |
| 3    | 228187   | •NIPPLE        | 1    |
| 4    | 101714   | •GABLET        | 1    |
| 5    | 218249   | NUT, FLANGED   | 1    |

# OPERATION

## TROUBLE SHOOTING

| PROBLEM                                       | CAUSE   | SOLUTION  |
|---|---|---|
| Machine does not operate.                     | Faulty power cord.  | Contact Service Center.   |
|   | Fuse blown or circuit breaker tripped in the building.          | Replace fuse or reset breaker.  |
|   | Faulty MASTER switch.   | Contact Service Center.   |
|   | Loose wiring to solution pump.                                  | Contact Service Center.   |
| Uneven or no spray.                           | Plugged or worn spray tips.                                     | Remove spray tips and clean.  |
|   | Pump needs priming.   | Turn on MASTER SWITCH, then push on the quick disconnect coupler to prime.                        |
|   | Solution tank filters are plugged.                              | Remove and clean the filters.   |
|   | Solution pump is faulty.  | Contact Service Center.   |
|   | Loose or broken wiring to solenoid or faulty solenoid.          | Contact Service Center.   |
| Little or no vacuum suction.                  | Drain valve T–handle open.                                      | Push T–Handle to close valve.   |
|   | Lint on top of standpipe screen.                                | Clean the screen.   |
|   | Air is leaking around recovery dome.                            | Tighten the two dome knobs or replace gasket.   |
|   | Loose vacuum hose at the recovery tool or at the recovery dome. | Tighten the hose. Also check to make sure the hose cuff is threaded onto the hose tightly.        |
|   | Defective vacuum hose.  | Replace the hose.   |
|   | Faulty vacuum motor.  | Contact Service Center.   |
| Drain valve leaks.                            | Drain valve seals are worn.                                     | Replace seals.  |
|   | Lint or dirt in drain valve.                                    | Remove the valve and clean it. If gate is worn, the valve may need replacement.                   |
| Brush motor operates but brush does not spin. | Loose or broken drive belt .                                    | Tighten or replace drive belt.  |
|   | Loose brush pulley or motor pulley.                             | Tighten set screw on the loose pulley.  |
| Brush motor does not operate.                 | Must press CARPET CLEANING button to operate the brush.         | Push CARPET CLEANING button.  |
|   | Tripped brush circuit breaker.                                  | UNPLUG THE MACHINE. Remove clogging debris from brush, then push BRUSH RESET button on switchbox. |
|   | CARPET CLEANING button is faulty.                               | Contact Service Center.   |
|   | Loose or broken wiring.   | Contact Service Center.   |
|   | Faulty brush motor.   | Contact Service Center.   |

## WIRING DIAGRAM

120V

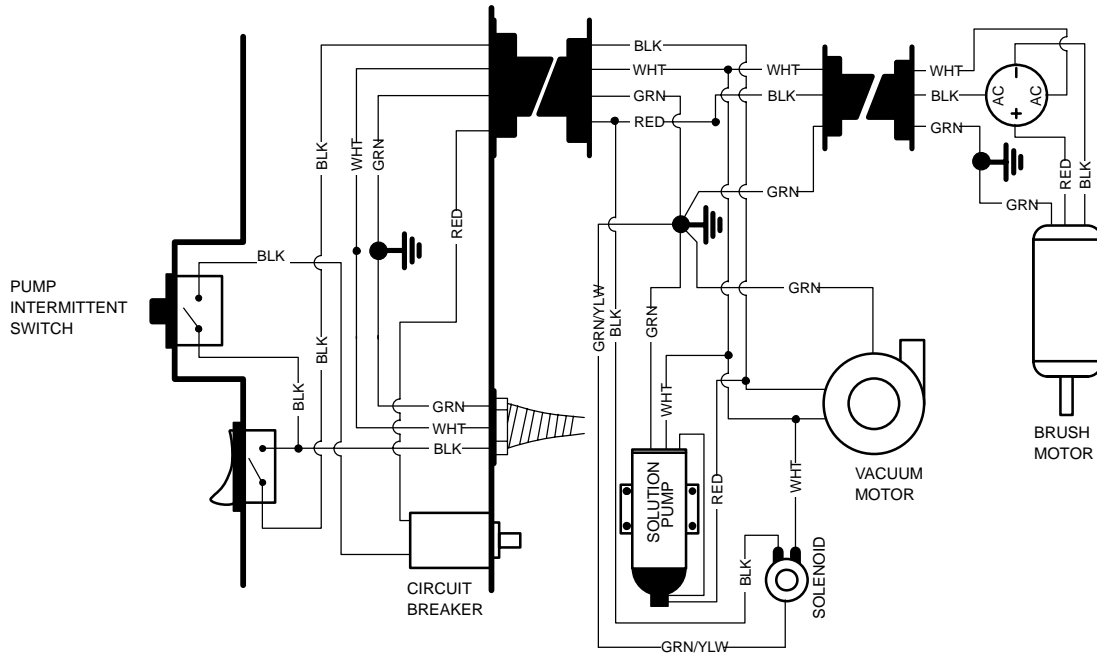

230V/240V

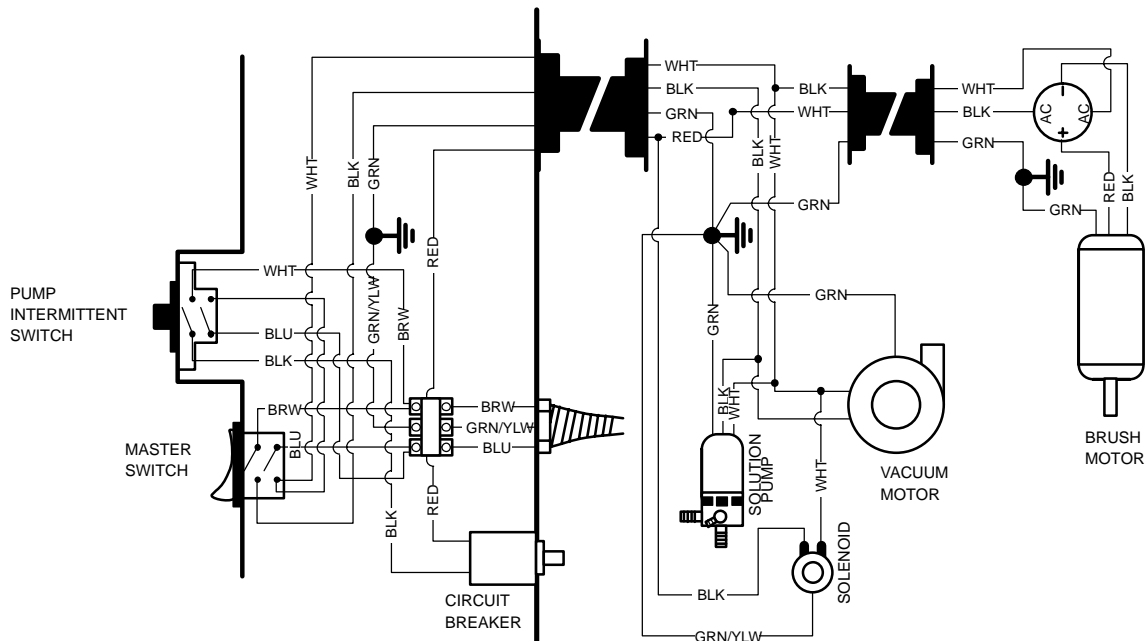

RECOVERY TANK GROUP

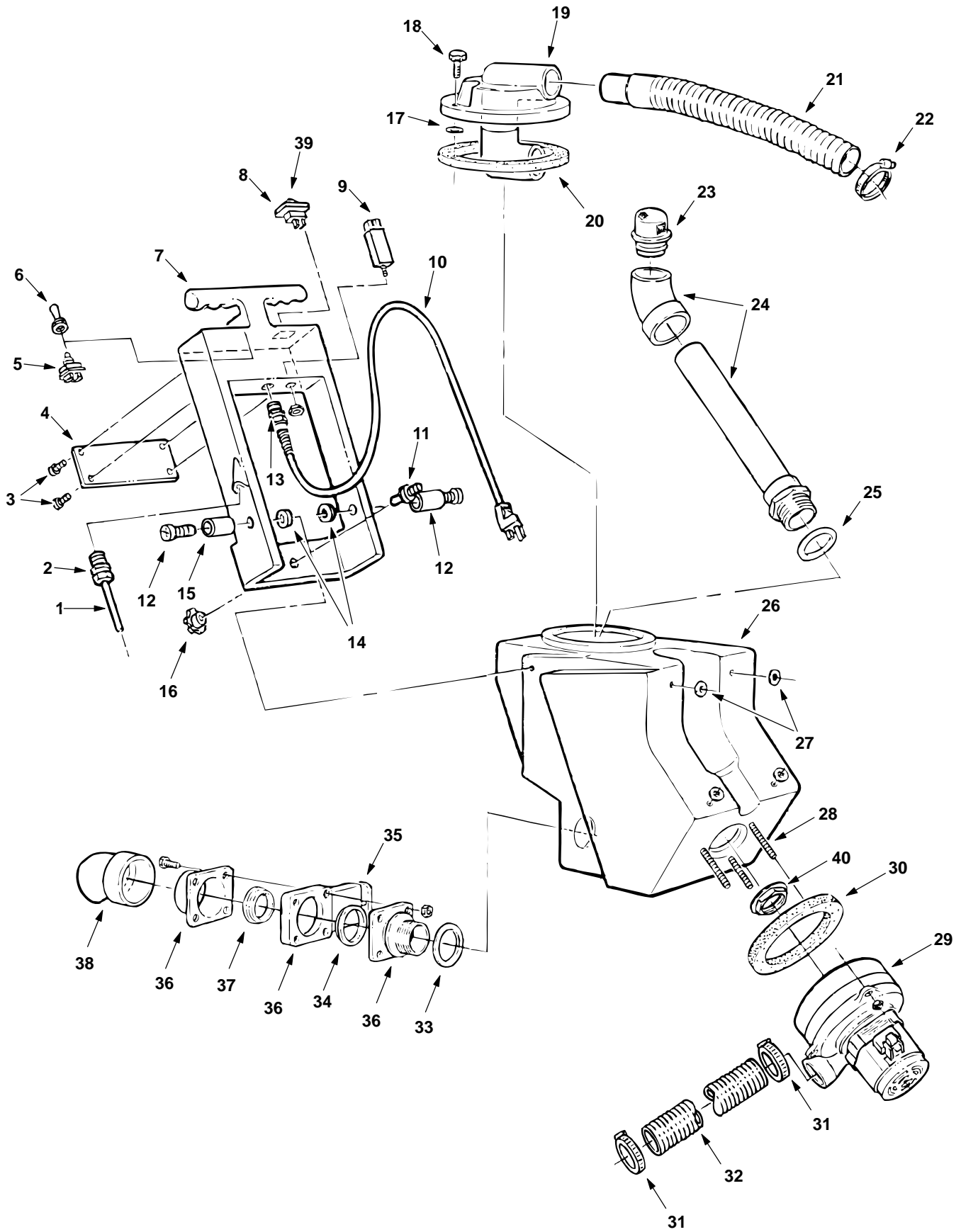

## RECOVERY TANK GROUP

| REF | PART #    | DESCRIPTION                           | QTY. |
|-----|-----------|---------------------------------------|------|
| 1.  | 130663    | CORD, 16/4X54"                        | 1    |
| 2.  | 130181    | CORD GRIP                             | 1    |
| 3.  | 140887    | SCREW, 10-24X3/8                      | 4    |
| 4.  | 230604.BK | PLATE, COVER                          | 1    |
| 5.  | 130712    | SWITCH, PULSE (120V)                  | 1    |
|     | 24858     | SWITCH, PULSE (230V/240V)             | 1    |
| N/S | 140928    | SPACER, SWITCH (230V/240V)            | 1    |
| 6.  | 130664    | BOOT (FOR #130712)                    | 1    |
| 7.  | 101340    | HANDLE, BLUE                          | 1    |
| 8.  | 130717    | SWITCH, ROCKER (120V)                 | 1    |
|     | 130764    | SWITCH, ROCKER (230V/240V)            | 1    |
| 9.  | 130760    | BREAKER, CIRCUIT 1.5 AMP (120V)       | 1    |
|     | 130747    | BREAKER, CIRCUIT 1.2 AMP (230V/240V)  | 1    |
| N/S | 130005    | TERMINAL 3-POS STRIP (230V/240V)      | 1    |
| N/S | 140534    | NUT, 6-32 NYLON (230V/240V)           | 2    |
| N/S | 140879    | SCREW, 6-32X3/4 NYL (230V/240V)       | 2    |
| 10. | 130222    | CORD, 16/3X25' BK SJTO (120V)         | 1    |
|     | 600398    | CORD, 3X1.0MMX12M BK SJTO (230V/240V) | 1    |
| 11. | 230273    | STUD                                  | 1    |
| 12. | 140847    | SCREW, 3/8-16X1                       | 2    |
| 13. | 130166    | CORD GRIP (120V)                      | 1    |
|     | 130137    | CORD GRIP (230V/240V)                 | 1    |
| 14. | 140028    | WASHER, FLAT                          | 2    |
| 15. | 140907    | BUSHING                               | 2    |
| 16. | 240202    | KNOB                                  | 1    |
| 17. | 140037    | WASHER, NYLON                         | 2    |
| 18. | 240217    | KNOB, DOME                            | 2    |

| REF | PART #    | DESCRIPTION                  | QTY. |
|-----|-----------|------------------------------|------|
| 19. | 100112    | DOME                         | 1    |
| 20. | 100042    | GASKET, RECOVERY DOME        | 1    |
| 21. | 160426    | HOSE, VACUUM 1 1/2X15"       | 1    |
| 22. | 140307    | CLAMP, HOSE                  | 1    |
| 23. | 180612    | SCREEN, STANDPIPE            | 1    |
| 24. | 700145    | ASM, STANDPIPE               | 1    |
| 25. | 230159    | O-RING, STANDPIPE            | 1    |
| 26. | 602680    | TANK, RECOVERY, BLUE         | 1    |
| 27. | 100029    | GASKET, TANK CONNECTOR       | 4    |
| 28. | 140258    | STUD, THREADED               | 3    |
| 29. | 130415    | MOTOR, VAC 120V 5.7/2STG     | 1    |
|     | 190161    | BRUSH, CARBON (2/Pk)         | 2    |
|     | 130403    | MOTOR, VAC 240V 5.7/2STG     | 1    |
|     | 190158    | BRUSH, CARBON (2/Pk)         | 2    |
| 30. | 100038    | GASKET, VAC MOTOR            | 1    |
| 31. | 140308    | CLAMP, HOSE                  | 2    |
| 32. | 069760778 | HOSE, EXHAUST                | 2ft  |
| 33. | 210234    | GASKET, DRAIN VALVE          | 1    |
| 34. | 210239    | SEAL, GATE DRAIN VALVE       | 2    |
| 35. | 210237    | HANDLE, METAL DRAIN VALVE    | 1    |
| 36. | 210242    | VALVE, DRAIN W/ METAL HANDLE | 2    |
| 37. | 210239    | SEAL, GATE DRAIN VALVE       | 2    |
| 38. | 210232    | ELBOW, DRAIN VALVE DWNSPOUT  | 1    |
| 39. | 578720    | SPASHGUARD, ROCKER SWITCH    | 1    |
| 40. | 210240    | NUT, METAL                   | 1    |

● RECOMMENDED STOCK ITEMS

N/S = NOT SHOWN

## DECAL PARTS LIST (NOT SHOWN)

| REF | PART # | DESCRIPTION                   | QTY. |
|-----|--------|-------------------------------|------|
| N/S | 120905 | DECAL, OPERATION INSTRUCTIONS | 1    |
| N/S | 120414 | DECAL, DO NOT FILL            | 1    |
| N/S | 120409 | DECAL, RECOVERY TANK FULL     | 1    |
| N/S | 120617 | DECAL, HEIGHT ADJUSTMENT      | 1    |
| N/S | 120906 | DECAL, IMPORTANT DRAIN        | 1    |
| N/S | 120619 | DECAL, WARNING EXTRACTORS     | 1    |
| N/S | 120101 | DECAL, CASTEX LOGO            | 1    |
| N/S | 608043 | DECAL, SCX-350                | 2    |

SOLUTION TANK GROUP

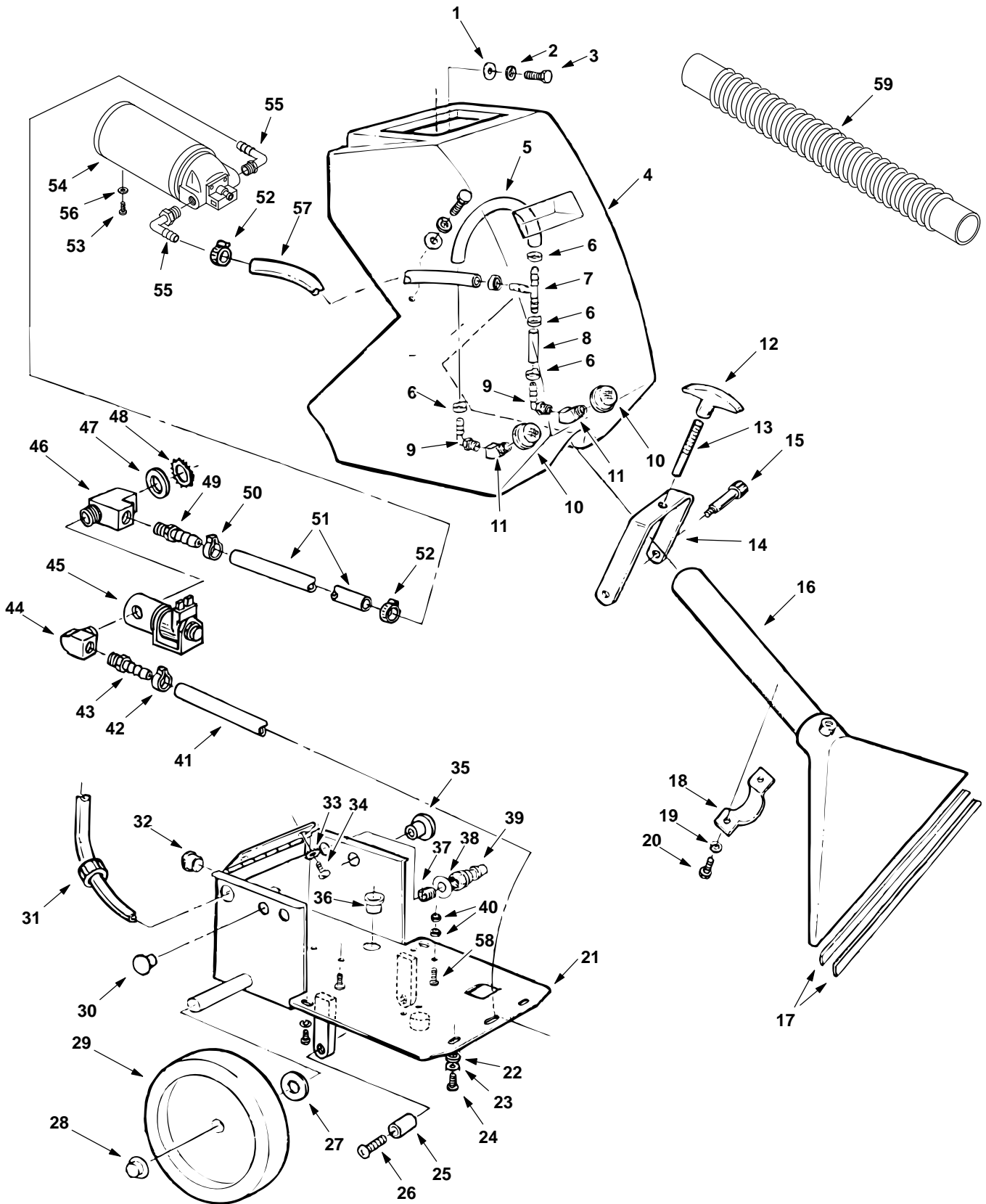

## SOLUTION TANK GROUP

| REF | PART #    | DESCRIPTION              | QTY. |
|-----|-----------|--------------------------|------|
| 1.  | 140003    | WASHER, FENDER           | 4    |
| 2.  | 140016    | WASHER, LOCK             | 4    |
| 3.  | 140554    | SCREW, 1/4-20X3/4        | 4    |
| 4.  | 100468    | TANK, SOLUTION, BLUE     | 1    |
| 5.  | 607411    | HOSE, 3/8 X 8" GRAY      | 1    |
| 6.  | 140301    | CLAMP, EAR               | 5    |
| 7.  | 160310    | TEE                      | 1    |
| 8.  | 607412    | HOSE, 3/8 X 2" GRAY      | 1    |
| 9.  | 150415    | ELBOW                    | 2    |
| 10. | 180628    | SCREEN, CLEAN WATER TANK | 2    |
| 11. | 150403    | ELBOW, STREET            | 2    |
| 12. | 240194    | KNOB, HEIGHT ADJ.        | 1    |
| 13. | 230382    | STUD, HEIGHT ADJ.        | 1    |
| 14. | 230638.BK | BRACKET, HEIGHT ADJ.     | 1    |
| 15. | 140564    | BOLT, SHOULDER 3/8X3/4   | 2    |
| 16. | 200452.BL | TOOL, FLOOR, BLUE        | 1    |
| 17. | 200939    | SHOE, FLOOR TOOL         | 2    |
| 18. | 140313    | CLAMP, FLOOR TOOL        | 1    |
| 19. | 140016    | WASHER, LOCK             | 2    |
| 20. | 140554    | SCREW, 1/4-20X3/4        | 2    |
| 21. | 230915.BK | CHASSIS, WELDMENT BLACK  | 1    |
| 22. | 140007    | WASHER, FLAT             | 4    |
| 23. | 140016    | WASHER, LOCK             | 4    |
| 24. | 140553    | SCREW, 1/4-20X1/2        | 4    |
| 25. | 140914    | SPACER, NYLON            | 2    |
| 26. | 140898    | SCREW, 3/8-16X3/4        | 2    |
| 27. | 140040    | WASHER, POLY             | 4    |
| 28. | 103019    | CAP, HUB                 | 2    |
| 29. | 103014    | WHEEL                    | 2    |
| 30. | 130164    | PLUG, DOME               | 2    |
| 31. | 130182    | BUSHING, STRAIN RELIEF   | 1    |

| REF | PART # | DESCRIPTION                 | QTY. |
|-----|--------|-----------------------------|------|
| 32. | 130161 | PLUG, DOME                  | 1    |
| 33. | 140052 | WASHER, LOCK                | 2    |
| 34. | 140885 | SCREW, 1/4-20X1/2           | 2    |
| 35. | 130154 | PLUG, DOME                  | 1    |
| 36. | 130104 | BUSHING                     | 1    |
| 37. | 150615 | NIPPLE, BRASS               | 1    |
| 38. | 140034 | WASHER, FLAT                | 2    |
| 39. | 150933 | PLUG, QUICK COUPLER         | 1    |
| 40. | 140519 | NUT, KEP                    | 2    |
| 41. | 607413 | HOSE, 3/8 X 17.25" GRAY     | 1    |
| 42. | 140325 | CLAMP                       | 1    |
| 43. | 150515 | HOSE BARB                   | 1    |
| 44. | 150406 | ELBOW, STREET               | 1    |
| 45. | 210033 | VALVE, SOLENOID (120V)      | 1    |
|     | 604073 | VALVE, SOLENOID (220V/60HZ) | 1    |
|     | 210260 | VALVE, SOLENOID (240V/50HZ) | 1    |
| 46. | 150709 | TEE, BRASS STREET           | 1    |
| 47. | 140058 | WASHER                      | 1    |
| 48. | 140030 | WASHER, LOCK                | 1    |
| 49. | 150516 | HOSE BARB                   | 1    |
| 50. | 140301 | CLAMP                       | 1    |
| 51. | 607415 | HOSE, 3/8 X 4" GRAY         | 1    |
| 52. | 140310 | CLAMP, HOSE                 | 2    |
| 53. | 140872 | SCREW, #6X3/8               | 2    |
| 54. | 606778 | PUMP (120V)                 | 1    |
|     | 180119 | PUMP (240V)                 | 1    |
| 55. | 150412 | FITTING, 3/8M X 3/8 H ELBOW | 2    |
| 56. | 140000 | WASHER                      | 2    |
| 57. | 607414 | HOSE, CLEAR 3/8 X 21"       | 1    |
| 58. | 140895 | SCREW, 10-24X3/4            | 1    |
| 59. | 160424 | HOSE, CLEANOUT              | 1    |

● RECOMMENDED STOCK ITEMS

POWER BRUSH GROUP

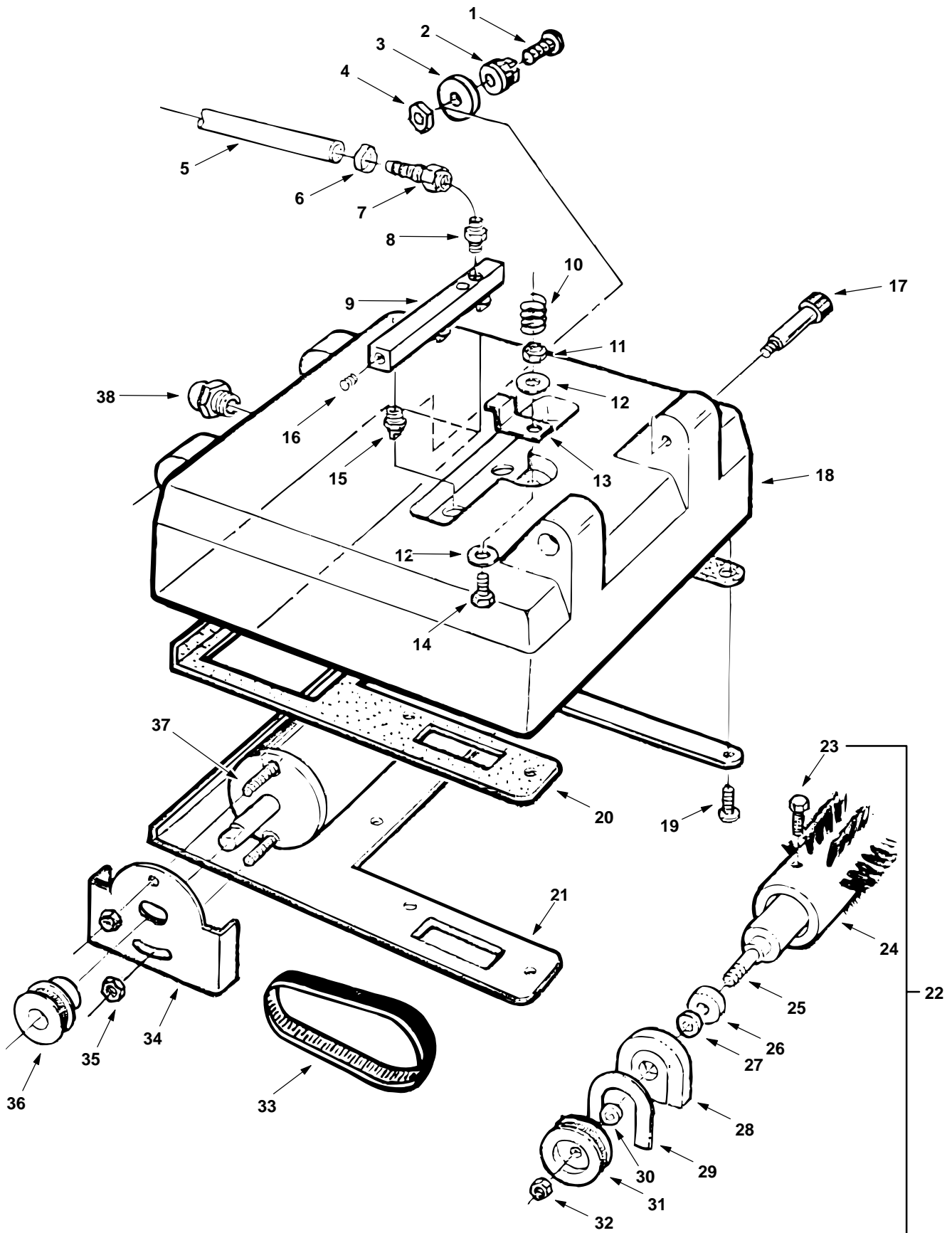

## POWER BRUSH GROUP

| REF | PART #    | DESCRIPTION              | QTY.   |
|-----|-----------|--------------------------|--------|
| 1.  | 140831    | SCREW, 6/32X5/8          | 1      |
| 2.  | 130304    | RECTIFIER                | 1      |
| 3.  | 140041    | WASHER, FENDER           | 1      |
| 4.  | 140539    | NUT, KEP                 | 1      |
| 5.  | 160204    | HOSE                     | 1.42ft |
| 6.  | 140325    | CLAMP                    | 2      |
| 7.  | 150526    | HOSE BARB                | 1      |
| 8.  | 150616    | ADAPTER                  | 1      |
| 9.  | 230254    | SPRAYBAR MANIFOLD        | 1      |
| 10. | 140407    | SPRING                   | 1      |
| 11. | 140515    | NUT, LOCK                | 1      |
| 12. | 140028    | WASHER, FLAT             | 2      |
| 13. | 230264.BK | CLAMP, SPRAYBAR MANIFOLD | 1      |
| 14. | 140233    | SCREW, 3/8-16X3/4        | 1      |
| 15. | 200979    | NOZZLE                   | 3      |
| 16. | 150208    | PLUG, BRASS COUNTERSUNK  | 3      |
| 17. | 140564    | BOLT, SHOULDER           | 2      |
| 18. | 602679    | HOUSING, BRUSH, BLUE     | 1      |
| 19. | 140887    | SCREW, 10-24X3/8         | 10     |
| 20. | 100026    | GASKET, BASE PLATE       | 1      |
| 21. | 100733.BK | PLATE, BRUSH             | 1      |

| REF  | PART # | DESCRIPTION               | QTY. |
|------|--------|---------------------------|------|
| ∇22. | 700816 | ASM, BRUSH                | 1    |
| ▲23. | 140554 | SCREW, 1/4-20X3/4         | 4    |
| ▲24. | 240037 | BRUSH, CYLINDER           | 1    |
| ▲25. | 230275 | SHAFT, BRUSH BEARING      | 1    |
| ▲26. | 100049 | SEAL, BRUSH BEARING       | 2    |
| ▲27. | 140125 | BEARING, BRUSH            | 2    |
| ▲28. | 230261 | BLOCK, BEARING            | 2    |
| ▲29. | 100005 | GASKET, BEARING BLOCK     | 1    |
| ▲30. | 230363 | SPACER                    | 1    |
| ▲31. | 230505 | PULLEY, BRUSH             | 1    |
| ▲32. | 140548 | NUT, FINISHED JAM         | 1    |
| 33.  | 230507 | BELT, BRUSH DRIVE         | 1    |
| 34.  | 230366 | PLATE, MOTOR MOUNT        | 1    |
| 35.  | 140518 | NUT, KEP                  | 2    |
| 36.  | 230506 | PULLEY, MOTOR             | 1    |
| 37.  | 130471 | MOTOR, BRUSH DRIVE (120V) | 1    |
|      | 190150 | BRUSH CARD                | 1    |
|      | 130472 | MOTOR, BRUSH DRIVE (220V) | 1    |
|      | 190154 | BRUSH CARD                | 1    |
| 38.  | 130190 | CORD GRIP                 | 1    |

∇ ASSEMBLY

▲ INCLUDED IN ASSEMBLY

● RECOMMENDED STOCK ITEMS

# OPTIONS

## 127 mm (5 inch) HAND TOOL

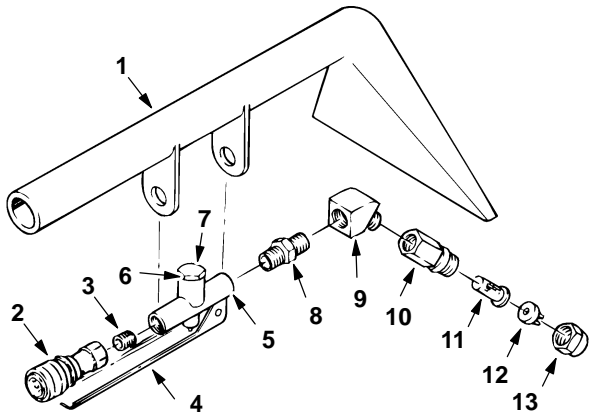

| REF | PART #    | DESCRIPTION                      | QTY. |
|-----|-----------|----------------------------------|------|
|     | 200505    | TOOL, HAND (COMPLETE)            | 1    |
| 1   | 200431.BK | TOOL, HAND                       | 1    |
| 2   | 150913    | COUPLER, QUICK (SER. 60)         | 1    |
| 3   | 150615    | NIPPLE, CLOSE                    | 1    |
| 4   | 200905    | TRIGGER, HAND TOOL               | 1    |
| 5   | 210210    | ● VALVE, FLOW CONTROL            | 1    |
| 6   | 190600    | ● VALVE PIN & SPRING (NOT SHOWN) | 1    |
| 7   | N/A       | ● CAP, VALVE                     | 1    |
| 8   | 150606    | NIPPLE, HEX 1/4                  | 1    |
| 9   | 150403    | ELBOW, ST 1/4 45°                | 1    |
| 10  | 200992    | BODY, SPRAY 1/4F                 | 1    |
| 11  | 200996    | ● SCREEN, SPRAY NOZZLE           | 1    |
| 12  | 200965    | ● TIP, SPRAY #8002               | 1    |
| 13  | 200994    | CAP, SPRAY BODY                  | 1    |

## SOLUTION AND VACUUM HOSES

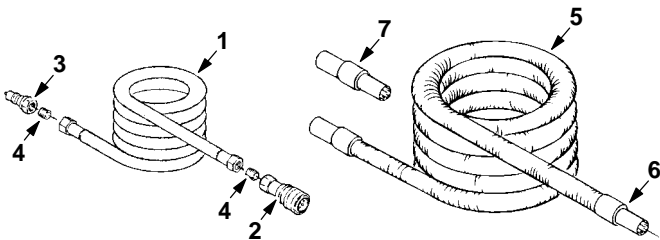

| REF | PART # | DESCRIPTION                   | QTY. |
|-----|--------|-------------------------------|------|
| ∇1  | 160185 | HOSE, SOLUTION 15'            | 1    |
|     | 160186 | HOSE, SOLUTION 25'            | 1    |
| ▲2  | 150913 | COUPLER, QUICK SER. 60        | 1    |
| ▲3  | 150933 | PLUG, QUICK COUPLER           | 1    |
| ▲4  | 150615 | NIPPLE                        | 2    |
| ∇5  | 160400 | HOSE, VACUUM 15' W/ CUFFS     | 1    |
|     | 160401 | HOSE, VACUUM 25' W/ CUFFS     | 1    |
| ▲6  | 160430 | CUFF, HOSE 1-1/2"             | 2    |
| 7   | 160451 | CONNECTOR, VACUUM HOSE 1-1/2" | 1    |

VASSEMBLY

▲ INCLUDED IN ASSEMBLY

● RECOMMENDED STOCK ITEMS

## FLOOR TOOL

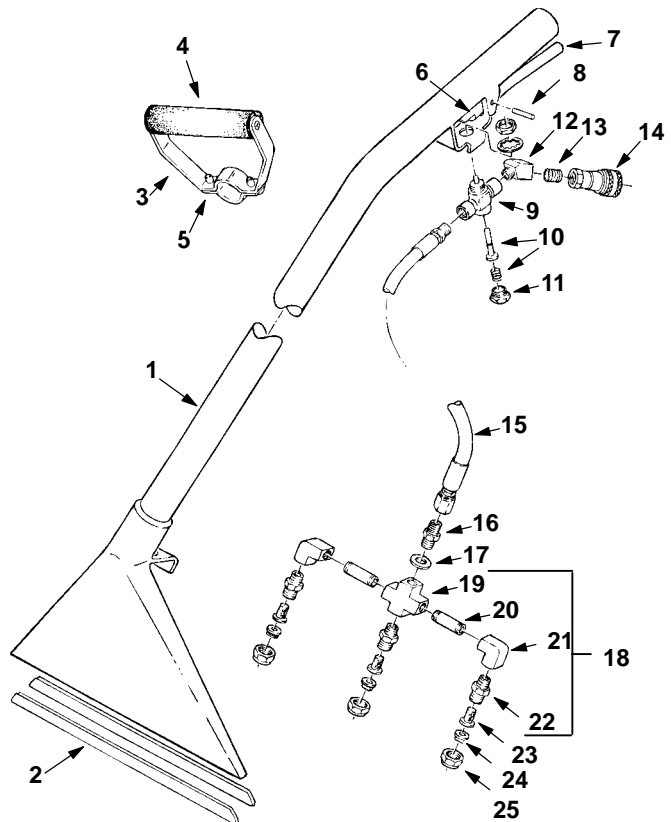

| REF | PART #    | DESCRIPTION                 | QTY. |
|-----|-----------|-----------------------------|------|
|     | 600048    | FLOOR TOOL (COMPLETE)       | 1    |
| 1   | 200403.BK | TOOL, FLOOR                 | 1    |
| 2   | 200939    | SHOES, S/S, FLOOR TOOL      | 2    |
| 3   | 200927    | GRIP, ADJUSTABLE (COMPLETE) | 1    |
| 4   | 200912    | FOAM, GRIP                  | 1    |
| 5   | 140259    | SCREW, 1/4-20X5/8           | 1    |
| 6   | 200902    | TRIGGER, FLOOR TOOL         | 1    |
| 7   | 200809    | SLEEVE, TRIGGER             | 1    |
| 8   | 140605    | PIN                         | 1    |
|     | 140520    | NUT, PUSH (NOT SHOWN)       | 2    |
| 9   | 210150    | ● VALVE, FLOW CONTROL       | 1    |
| 10  | 190603    | ● KIT, VALVE PIN & SPRING   | 1    |
| 11  | N/A       | ● CAP, HEX, VALVE           | 1    |
| 12  | 150403    | ELBOW, 1/4-45°              | 1    |
| 13  | 150615    | NIPPLE, CLOSE 1/4           | 1    |
| 14  | 150913    | COUPLER, QUICK SER. 60      | 1    |
| 15  | 160170    | HOSE, SOLUTION, LP          | 1    |
| 16  | 150606    | NIPPLE, HEX 1/4"            | 1    |
| 17  | 140058    | WASHER                      | 1    |
| ∇18 | 700062    | ASM., SPRAY BAR             | 1    |
| ▲19 | 150700    | CROSS                       | 1    |
| ▲20 | 150600    | NIPPLE                      | 2    |
| ▲21 | 150401    | ELBOW, 90° 1/4FX1/4F        | 2    |
| ▲22 | 200993    | SPRAY BODY                  | 3    |
| 23  | 200996    | ● SCREEN, SPRAY BODY        | 3    |
| 24  | 200964    | ● TIP                       | 3    |
| 25  | 200994    | CAP, SPRAY BODY             | 3    |