

TORNADO® INDUSTRIES
7401 W. LAWRENCE AVENUE
CHICAGO, IL 60706
(708) 867-5100 FAX (708) 867-6968
www.tornadovac.com

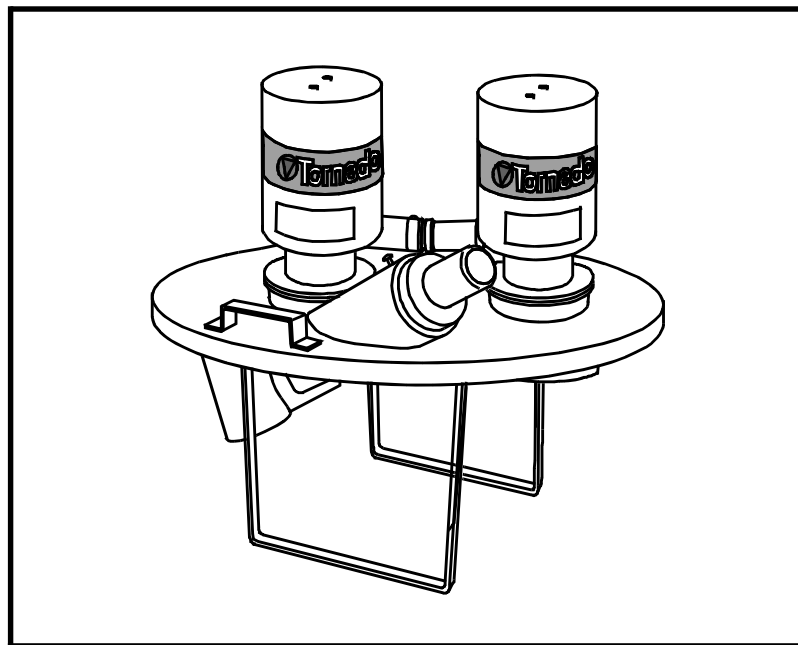

Tornado®

Operation & Maintenance Manual For Commercial Use Only



MODEL
95961

DUAL INTERNAL AIR HEAD ASSEMBLY

Tornado Dual Internal Air Head Assembly

Table of Contents

General Specifications.....	2
Unit Specifications	
Warranty.....	3
Safety Instructions.....	4
Warnings.....	5
Head Assembly Setup.....	6
Unit/Drum Assembly	
Operation.....	6
Start/Stop Machine	
Operating Rules	
Troubleshooting.....	7
Things To Know.....	8
Facts	
Compressor Evaluation	
Spare Parts.....	9-11

Features:

- Capable of wet/moist pickup.
- Ideal for materials from water to oil covered metal chips, grindings and shavings.
- 3/16" (5mm) jets installed. 7/32" (5.5mm) and 1/4" (6mm) jets are included for heavier debris.
- 90 p.s.i at the gauge (valve fully open) allows for maximum pickup power.
- 60 p.s.i. at the gauge (valve fully open) allows for lighter liquid pickup power.
- A heavy duty 55-gallon rolled top drum is required, and is available from Tornado.

Tornado Dual Internal Air Head Assembly

General Specifications

The Dual Internal Air Head Assembly is a heavy duty wet only industrial vacuum. It will pick up wet and moist waste without the need to change any filters. This compressed air vacuum has no moving parts and has tremendous suction for a portable unit. It is designed to fit onto a 55-gallon rolled top steel drum (Tornado # 95942) for volume pick-up with maximum efficiency. All recovered products go into the drum, therefore maintaining peak performance. The included liquid shut off attachments prevent over filling of the drum. Use for volume pickup of light to medium oils, liquid sludge, and many other light to medium viscosity liquids. Designed to perform at maximum efficiency with 2" hoses and attachments (refer to attachments section of this manual).

Unit Specifications

95961 INCLUDES:

- 95990 Venturi Powerhead (2)
- 95000 Jumbo Cover (1)
- 90442 Deflector (1)
- 90332 2" Hose Adaptor (1)
- 95992 Dual Head Line Connector (1)
- 90569 Liquid Shut Off (2)

HORIZONTAL RECOVERY (reach)	50 ft.
VERTICAL RECOVERY (lift)	25 ft.
REQUIRED COMPRESSOR	25 h.p.
AIR LINE AND COUPLINGS	3/4" (minimum), quick-connect, chicago, or fixed
HOSE ADAPTOR	2" Included
COLOR	Tornado Grey
WEIGHT	75 lbs.
3/16" JET (installed) w/1.5" HOSE	52 CFM/179" Static Waterlift
3/16" JET 2" HOSE	158 CFM/179" Static Waterlift
COMPRESSOR CFM	94 @ 90 p.s.i.
7/32" JET (included) w/1.5" HOSE	144 CFM/217" Static Waterlift
7/32" JET 2" HOSE	152 CFM/217" Static Waterlift
COMPRESSOR CFM	122 @ 90 p.s.i.
1/4" JET (included) w/1.5" HOSE	134 CFM/239" Static Waterlift
1/4" JET 2" HOSE	151 CFM/239" Static Waterlift
COMPRESSOR CFM	152 @ 90 p.s.i.

Tornado Dual Internal Air Head Assembly

Tornado® Standard Warranty Program*

10 Years: All plastic tanks and rotationally-molded bodies

2 Years: Parts and Labor on all Tornado and Tornado/Karcher cleaning equipment **

1 Year: Warranty on batteries, one full year, not pro-rated.

Warranties do not cover components subject to normal wear or abuse and misuse, and have other limitations not specified here. For full details, contact your Authorized Tornado Distributor, Service Center, or the Tornado Technical Service Department.

* Effective January 1st, 2000. Terms subject to change without notice.

** Windshear™ Blower-Dryer, Insulation Blowers, CW 50, CW 100, and Duo Upright Carpetkeepers™ are warranted for 1 (one) year for parts and labor.

Tornado Dual Internal Air Head Assembly

Safety Instructions

When using this unit, basic precautions should always be followed. Read all instructions before using this unit.



WARNING: To reduce the risk of fire, electric shock or injury:

Do not leave machine unattended when running. Turn off when not in use.

Before attempting any maintenance or adjustment, disconnect air lines.

Do not expose to rain.

Do not allow to be used as a toy. Close attention is necessary when used by or near children.

Use only as described in this manual. Use only manufacturer's recommended attachments.

If machine is not working as it should, has been dropped, damaged, left outdoors, or dropped into water, return it to a service center.

Keep hair, loose clothing, fingers, and all parts of body away from openings and moving parts.

Turn off all controls before disconnecting air lines.

Do not put any object into openings. Do not use with any opening blocked. Keep openings free of dust, lint, hair, and anything that may reduce air flow.

Do not pick up anything that is burning or smoking, such as cigarettes, matches, or hot ashes.

Do not pick up flammable or combustible liquids, such as gasoline, or use machine where they may be present.

Do not use without filters in place.

Use extra care when cleaning on stairs.

Always replace worn or torn external filters immediately. This will prevent possible injury due to flying objects.

Never operate with intake unguarded. Strong suction will pull fingers and/or clothing into hose and other parts.

Always wear safety glasses when in vicinity of this unit.

Never operate above 100 p.s.i. (8 BAR) pressure.

Always turn off your air line supply at the drop before disconnecting the air line.

Tornado Dual Internal Air Head Assembly



WARNING: Failure to adhere to these instructions could result in serious bodily injury or property damage.

BEFORE OPERATING MACHINE:

Read this manual completely before attempting to operate machine. This manual has important information for the use and safe operation of the machine. Keep this manual on file and handy. If additional information is needed, please contact your local distributor or write to:

TORNADO INDUSTRIES
7401 W. LAWRENCE AVE.
CHICAGO, IL 60656-3489

(708) 867-5100
Fax: (708) 867-6968
www.tornadovac.com

Tornado Dual Internal Air Head Assembly

Head Assembly Setup and Operation

ASSEMBLY OF HEAD UNIT AND DRUM

1. Remove all components from package.
2. The Venturi Powerhead(s) come already attached to the Jumbo Covers. To detach, remove the double unit air connector, then turn powerhead(s) counter-clockwise and they will unlock from the Jumbo Cover.
3. Install hose adaptor onto Jumbo Housing. Lock in place by lining up adaptor indent with lock screw and tightening lock screw.
4. Place head unit onto drum (required accessory). The weight and suction power of the head unit will form a seal on the drum.

OPERATING RULES

Use 1.5" to 2" I.D. hoses and attachments.

Use 3/4" air line hose and flow-thru quick connects (do not use ball style fittings).

90 p.s.i. (7 BAR) at gauge (valve open) for maximum pickup power, 60 p.s.i. (5 BAR) at gauge (valve open) for lighter debris recovery.

Use to recover water, heavy oils and oil soaked metal shavings.

IMPORTANT: The internal air vacuums do not have internal filters for dry recovery. They are assembled with silencers built inside the venturi powerhead and are designed for wet application only.

Breuer Tornado does offer an optional internal filter kit that will convert this unit to a dry and moist pickup vacuum. Please note that if this conversion is done, it will be considered a dry/moist pickup vacuum only, and cannot be used for any wet/liquid pickup of any kind. Contact Breuer Tornado for more information on this conversion kit.

STARTING/STOPPING MACHINE

1. Connect air supply line to head line connector.
2. Start vacuum by turning air valve located on line connector to its ON position.
3. Stop vacuum by turning air valve located on line connector to its OFF position.

NOTE: Empty and clean vacuum and attachments after each days use for maximum performance.

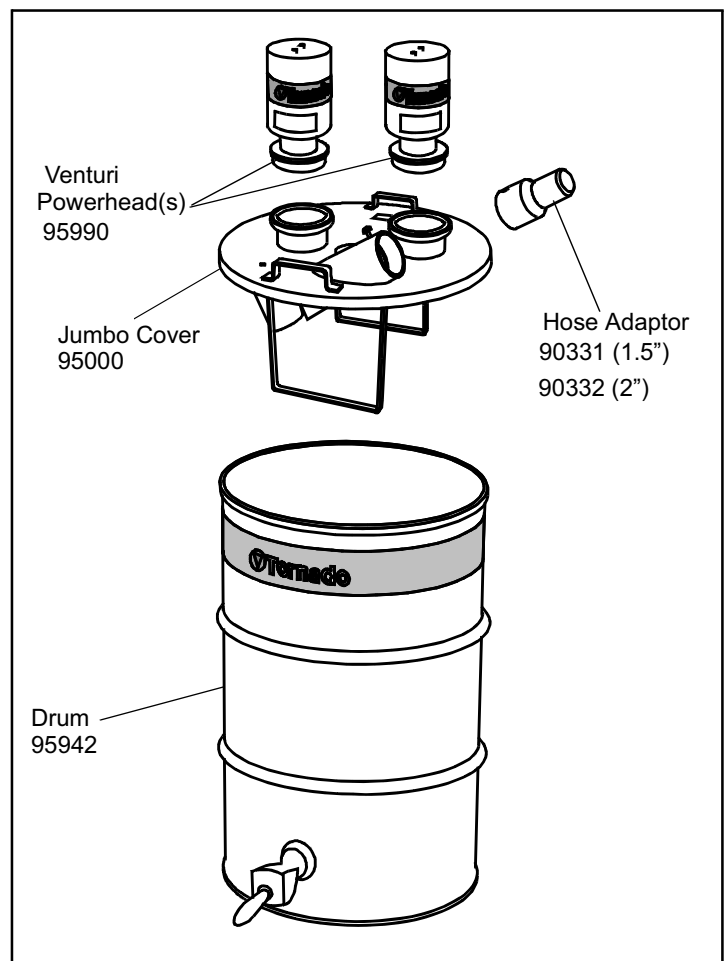

Tornado Dual Internal Air Head Assembly

Troubleshooting Guidelines

<u>Problem</u>	<u>Remedy</u>
1. Machine does not operate	<p>Make sure air line valve is in ON position.</p> <p>Inspect air regulators for interference of air flow.</p> <p>Inspect air compressor for adequate size, and verify that proper air pressure is available (60 to 90 p.s.i.)</p> <p>Inspect air line for proper size and/or damage.</p> <p>Always use flow thru connectors.</p>
2. Machine stops running	<p>Inspect drum level.</p> <p>Inspect air line for damage.</p> <p>Inspect air pressure.</p>
3. Machine has no suction	<p>Inspect for clogged hose, collapsed hose, defective drum, material too heavy for unit.</p>
4. Air pressure drops at gauge	<p>Inspect air compressor for proper free air consumption and resistance in air line size or connections.</p>
5. Machine has poor recovery	<p>Inspect for correct size hose and attachments, poor sealing, defective drum, material too heavy for unit.</p> <p>Inspect for proper drum cover seal (gasket).</p> <p>Inspect for damage and/or wear to hose and accessories.</p> <p>Inspect locked position(s) of venturi powerhead(s) to jumbo cover.</p> <p>Inspect all seals for wear and/or damage.</p>

Tornado Dual Internal Air Head Assembly

Things To Know

COMPRESSED AIR VACUUM FACTS

1. Use the smallest air jet possible to do the job. The smaller the jet, the lower the compressed air C.F.M. required.
2. Use a single venturi unit where liquid recovery is the primary application. A single venturi will recover liquids as fast as a double venturi will, yet consumes only one half as much compressed air.
3. Use a double venturi or quad venturi unit where higher volume of vacuum air is required. Remember, compressor overload is more likely to occur with a quad than a double venturi.
4. Use the lowest air line pressure possible per the given jet size to do the job. The lower the line pressure, the lower the compressed air consumption.
5. Air line **must** be maintained at the valve of the venturi unit. If pressure is not maintained at the unit, vacuum performance **will not** be reached. Be sure to use low line pressure for light liquid recovery, and high line pressure for liquids, sludge, and other heavy debris.
6. The air line hose should be as short as possible, and of maximum inside diameter (single 1/2", double 3/4", quad 1" recommended). Line air losses that occur are related to hose length and diameter, thus reducing performance.
7. Any air line moisture (condensation) should be eliminated. Using a water trap in the air line to the venturi unit will help maintain peak performance.
8. Air line components can reduce performance. Quick disconnect couplings and line filters, for example, may reduce compressed air delivery.
9. Factors that affect compressed air supply are compressor horsepower rating, compressor C.F.M. rating, and system resistance of installed air lines.

AIR COMPRESSOR EVALUATION

Independent of high horsepower or high compressor C.F.M. rating claims made by individuals, the final evaluation in determining if a compressor is capable of supplying enough compressed air, is to demonstrate the air vacuum with a pressure gauge at the venturi unit. This will show the actual pressure being maintained while the unit is operating (refer to fact #5). This approach will also compensate for air line system resistance losses. If the compressor cannot maintain the free air consumption necessary, the line pressure will drop. Consequently, the compressed air C.F.M. will also drop, thus reducing the vacuum or suction performance.

NOTE: The compressed air C.F.M. is not the same as the vacuum air C.F.M.

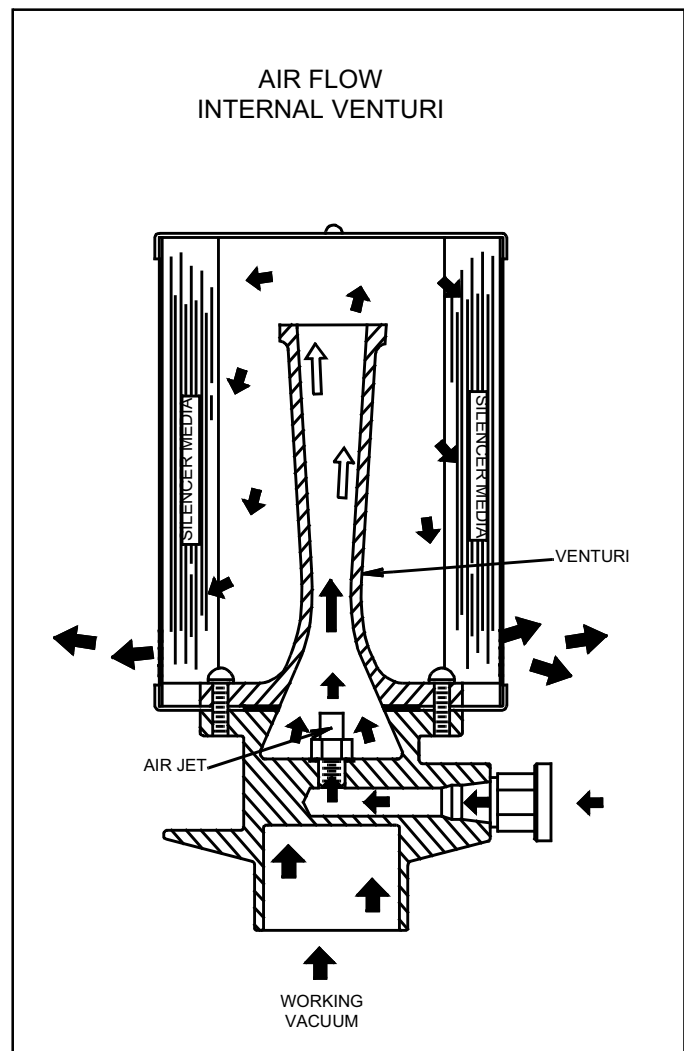

Tornado Dual Internal Air Head Assembly

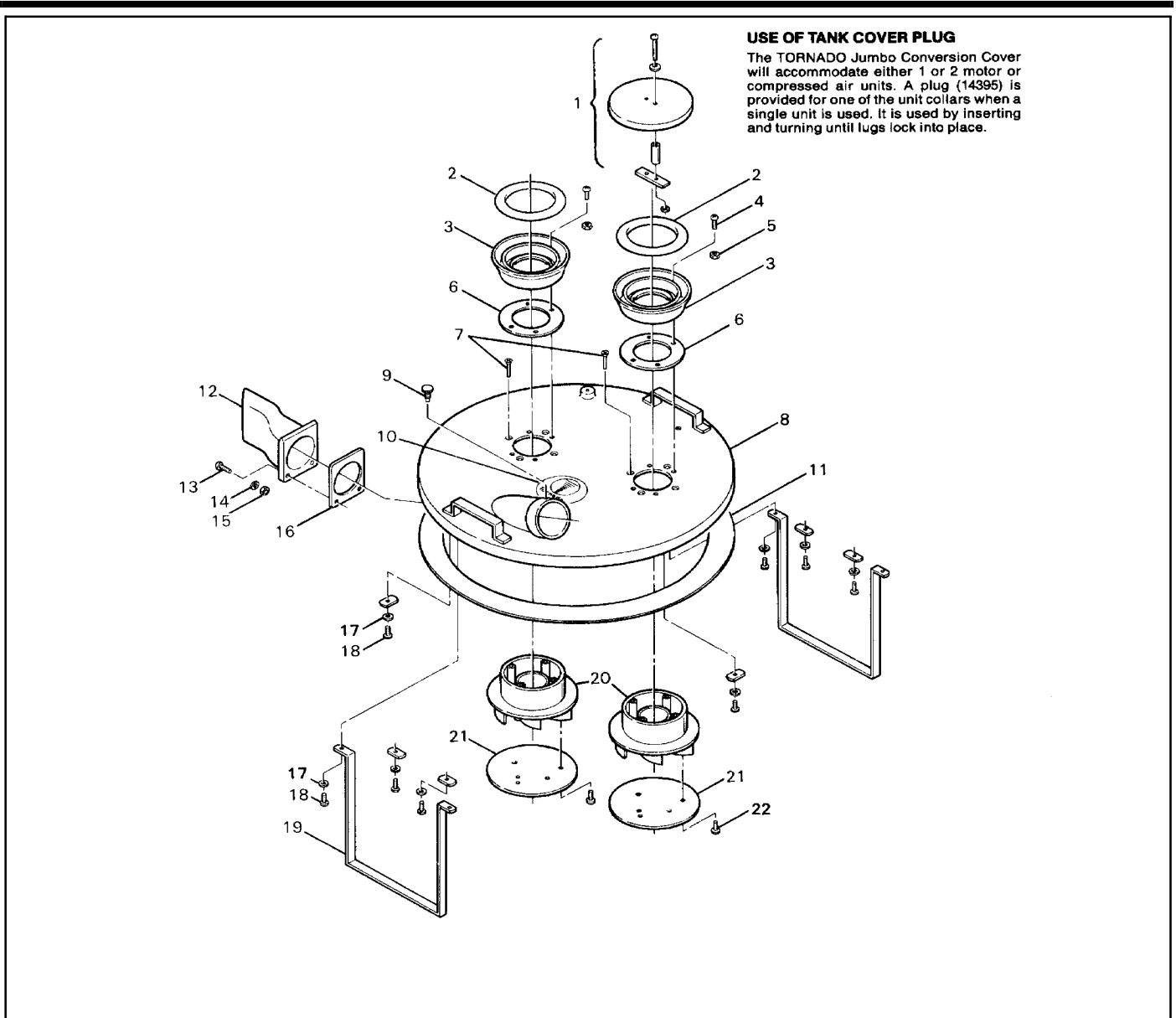

USE OF TANK COVER PLUG
 The TORNADO Jumbo Conversion Cover will accommodate either 1 or 2 motor or compressed air units. A plug (14395) is provided for one of the unit collars when a single unit is used. It is used by inserting and turning until lugs lock into place.

ITEM NO.	QTY.	PART NO.	DESCRIPTION	ITEM NO.	QTY.	PART NO.	DESCRIPTION
1	1	14395	TANK COVER PLUG ASSY.	14	2	01574	LOCKWASHER
2	2	08004	MOUNTING GASKET	15	2	01497	NUT
3	2	14415	ADAPTOR	16	1	04908	FLANGE GASKET
4	8	02053	SCREW	17	10	00851	WASHER
5	8	—	Nut	18	10	00086	SCREW
6	2	11386	GASKET	19	2	04997	STAND
7	8	11394	SCREW	20	2	11358	INTAKE GUIDE
8	1	13832	TANK COVER S/A	21	2	14731	TOP PLATE
9	1	08057	THUMB SCREW	22	6	11390	SCREW
10	1	07648	NAME PLATE				
11	1	4988	TANK COVER GASKET (6.5 FT.)				
12	1	90442	DEFLECTOR				
13	2	02038	SCREW				

Figure No. 3 Jumbo Cover Assembly

Tornado Dual Internal Air Head Assembly

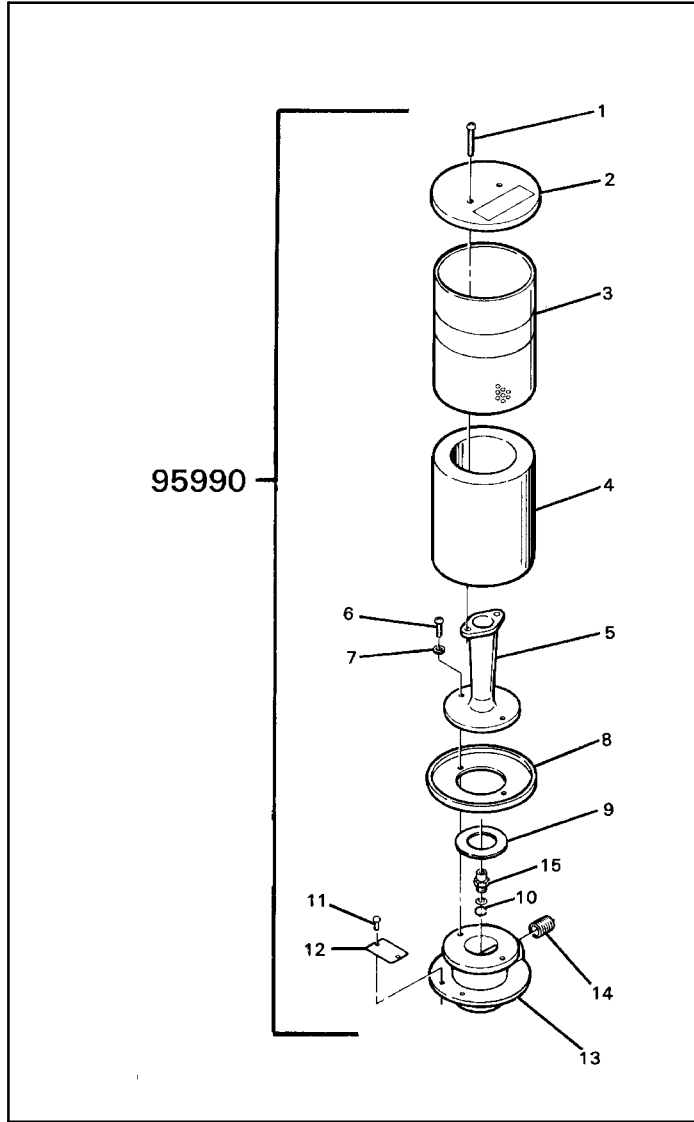

(95990) EXTERNAL FILTER AIR VAC

ITEM NO.	QTY.	PART NO.	DESCRIPTION
1	2	01979	SCREW
2	1	04928	MUFFLER COVER
3	1	15967	MUFFLER SHELL
4	1	95054	SILENCER
5	1	05723	NOZZLE
6	2	02038	SCREW
7	2	01574	LOCKWASHER
8	1	04927	MUFFLER BASE
9	1	05724	GASKET
10	3	02481	"O" RING
11	2	02573	DRIVE SCREW
12	1	04924	NAMEPLATE
13	1	11407	BASE
14	1	05730	NIPPLE
15	1	04982	JET (3/16" DIA.) INSTALLED
	1	04983	JET (7/32" DIA.)
	1	04984	JET (1/4" DIA.)
16	1	16511	WARNING LABEL

Tornado Dual Internal Air Head Assembly

DO NOT OPERATE WITHOUT
EXTERNAL FILTER BAG 90377 OR
90376 OR 90447 MUFFLER.

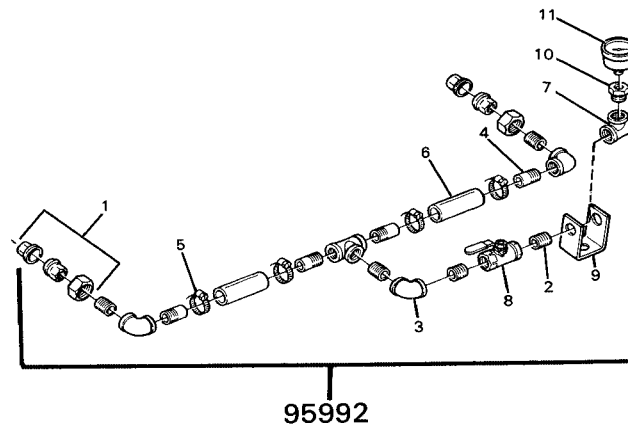

(95992) CONNECTOR ASSY. DOUBLE HEAD

ITEM NO.	QTY.	PART NO.	DESCRIPTION
1	2	06384	JOINT UNION
2	5	05730	NIPPLE
3	3	05729	90 ELBOW
4	4	05726	MALE ADAPTOR-HOSE TO PIPE
5	4	05727	CLAMP
6	2	11561	HOSE
7	2	05731	PIPE TEE
8	1	04985	VALVE
9	1	15163	BRACKET
10	1	05733	PIPE BUSHING
11	1	05732	AIR PRESSURE GAUGE