

TORNADO® INDUSTRIES CORP.
7401 W. LAWRENCE AVENUE
CHICAGO, IL 60706
(708) 867-5100 FAX (708) 867-6968
www.tornadovac.com



Operation, Maintenance, and Illustrated Parts List Manual
For Commercial Use Only



Wide Area Vacuum Cleaner

CATALOG NOS.
93030 & 93032

TABLE OF CONTENTS
(L3030 MANUAL)

<u>DESCRIPTION</u>	<u>PAGE(S)</u>
Performance Features.....	2
Machine Specifications / Warranty.....	3
Safety / Grounding Instructions.....	4-6
Assembly Instructions.....	7-8
Bag Installation Instructions.....	9
Brush Height Adjustment Instructions.....	10
Basic Operation Instructions.....	11
Filter Replacement Instructions.....	12
Belt Adjustment / Replacement.....	13
Full Assembly Exploded View	14-15
Full Assembly Parts List	16-17
Brush Assembly.....	18
Handle Assembly Exploded View	19
Handle Assembly Parts List	20
Wiring Diagram.....	21

PERFORMANCE FEATURES:

- Advanced Styling With Durable Construction
- Clean Air Filtration
- 30" Wide Cleaning Path
- Height-Adjustable Folding Handle
- 4-Row Chevron Brush (28" Long x 3" Diameter)
- PMDC Brush Motor, ½ HP, 2.3 Amps, 2600 RPM
- (2) Ametek Vacuum Motors:
 - 1 HP, 6.7 Amps, 98 CFM, 63" Waterlift
- 4 Stage "Clean Air" Filtration:
 - Stage 1: Disposable Paper Bag
 - Stage 2: High Efficiency Reusable Cloth Bag
 - Stage 3: Vacuum Motor Intake Filter
 - Stage 4: Motor Exhaust Filter Cartridge
- Rotationally Molded Housing and Lid
- 10" Diameter, 125 Lb. Rated Main Wheels
- 5 Foot-operated Brush Height Adjustment Levels
- Easy Access Poly-V Drive Belt
- Stainless Steel Brush Shoe
- 75 Foot Power Cord

Specifications

CATALOG NO.	93030	93032
SERIES	E	E
CLEANING PATH (WIDTH)	30"	30"
HP – BRUSH MOTOR	½ HP	½ HP
HP – VAC MOTOR	2 X 1 HP	2 X 1 HP
VOLTS	115V	115V
AMPS	15	15
CERTIFICATION	Pending	Pending

All specifications are subject to change without notice.

All information and specifications printed in the manual and parts list are current at the time of printing. However, because of Tornado's policy of continued product improvement, we reserve the right to make changes at any time without notice.

Tornado® Standard Warranty Program*

<p>Warranties do not cover components subject to normal wear or abuse and misuse, and have other limitations not specified here. For full details, contact your Authorized Tornado Distributor, Service Center, or the Tornado Technical Service Department.</p>	<p>10 Years: <i>All plastic tanks and rotationally-molded bodies</i></p>
	<p>2 Years: <i>Parts on all Tornado and Tornado/Karcher cleaning equipment ^{1) 2)}</i></p>
	<p>1 Year: <i>Labor on all Tornado and Tornado/Karcher cleaning equipment ^{1) 2)}</i></p>
	<p>1 Year: <i>Warranty on batteries, one full year, not pro-rated.</i></p>

* Effective January 1st, 2001. Terms subject to change without notice.

- 1) Windshear™ Blower-Dryer, Insulation Blowers, CW 50, CW 100, and Duo-Upright Carpetkeepers™ are warranted for 1 (one) year for parts and labor.
- 2) Warranties on the ICC1, KMR 1200, KMR 1250, and KMR 1700 are 24 months parts/6 months labor OR 1000 hours of operation, whichever comes first. Warranties on the BR and BD 1000 are 24 months parts/12 months labor OR 1000 hours of operation, whichever comes first.

**IMPORTANT SAFETY INSTRUCTIONS FOR
COMMERCIAL USE ONLY**
**WHEN USING AN ELECTRICAL APPLIANCE BASIC PRECAUTIONS SHOULD ALWAYS BE
FOLLOWED INCLUDING THE FOLLOWING:**

READ ALL INSTRUCTIONS BEFORE USING THE MACHINE



WARNING: To reduce the risk of fire, electric shock or injury:

Do not leave machine unattended when plugged in. Unplug from outlet when not in use and before changing bags or attempting any maintenance or adjustment.

To avoid electrical shock, Use indoors only. Do not use outdoors and do not expose to rain.

Do not allow to be used as a toy. Close attention is necessary when used by or near children.

Use only as described in this manual. Use only manufacturer's recommended attachments.

Do not use with damaged cord or plug. If machine is not working as it should, has been dropped, damaged, left outdoors, or dropped into water, return it to a service center.

Do not pull or carry by cord, use cord as a handle, close a door on cord, or pull cord around sharp edges or corners. Do not run machine over cord. Keep cord away from heated surfaces. Do not unplug by pulling on cord. To unplug, grasp the plug not the cord. Do not handle plug or machine with wet hands.

Keep hair, loose clothing, fingers, and all parts of body away from openings and moving parts.

Turn off all controls before unplugging.

Connect to a properly grounded outlet only. See Grounding Instructions.

Do not put hands under base - rotating parts could cause injury. Always keep hands feet and loose fitting clothing away from moving parts to prevent possible injuries. Use care to keep electrical supply cable from contacting moving parts, such as floor brushes.

Risk of explosion: Use this machine only in a well ventilated area, free from any flame or match. Do not use machine in areas where flammable and/or explosive vapors or dust are present.

Make sure voltage and frequency at the wall power receptacle correspond with that indicated on name plate before plugging in machine. A 20 amp circuit is recommended.

Never use a device to lock the switch lever in the ON position.

Use only a 12 Ga. three-wire extension cable which have 3-prong grounding type plugs and 3-prong receptacles that accept the machine's plug.

Save These Instructions

BEFORE OPERATING MACHINE



WARNING: Failure to adhere to these instructions could result in serious bodily injury or property damage.

Read this manual completely before attempting to operate machine. This manual has important information for the use and safe operation of the machine. Keep this manual on file and handy. If additional information is needed, please contact your local distributor or call:

TORNADO INDUSTRIES
7401 W. LAWRENCE AVE.
CHICAGO, IL 60706

(708) 867-5100
1-800-VACUUMS
Fax: (708) 867-6968
<http://www.tornadovac.com>

Grounding Instructions



WARNING: Improper connection of the equipment-grounding conductor can result in a risk of electric shock. Check with a qualified electrician or service person if you are in doubt as to whether the outlet is properly grounded. Do not modify the plug provided with the appliance - if it will not fit the outlet, have a proper outlet installed by a qualified electrician.

This appliance must be grounded. If it should malfunction or breakdown, grounding provides a path of least resistance for electric current to reduce the risk of electric shock. This machine is equipped with a cord having an equipment-grounding conductor and grounding plug. The plug must be inserted into an appropriate outlet that is properly installed and grounded in accordance with all local codes and ordinances.

This appliance is for use on a nominal 120-volt circuit, and has a grounding plug that looks like the plug illustrated in sketch A. A temporary adapter that looks like the adapter illustrated in sketches B and C may be used to connect this plug to a 2-pole receptacle (sketch B) if a properly grounded outlet is not available. The temporary adapter should be used only until a properly grounded outlet (sketch A) can be installed by a qualified electrician. The green-colored rigid ear, lug, or tab extending from the adapter must be connected to a permanent ground such as a properly grounded outlet box cover. Whenever the adapter is used, it must be held in place by a metal screw.

NOTE: In Canada, the use of a temporary adapter is not permitted by the Canadian Electrical Code.

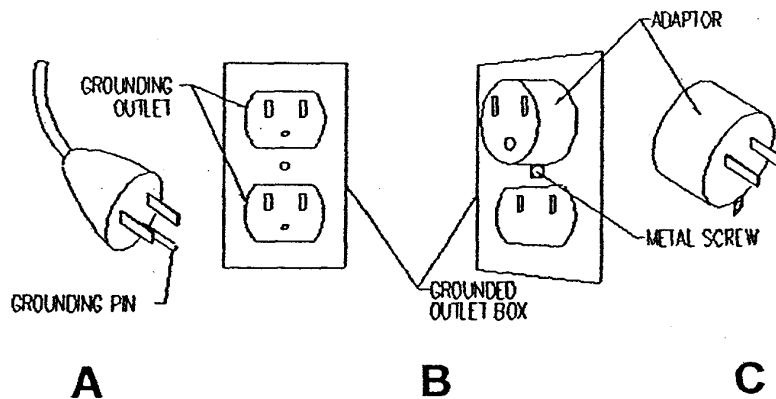

EXTENSION CORD

If an extension cord is used, use only a three wire 12 gauge extension cord that has three prong grounding type plugs and three prong receptacles that accept the machine's plug. This machine is equipped with a 14 gauge power cord. Replace or repair all damaged cords.

WHEN THE MACHINE IS DELIVERED

If machine is damaged, notify the carrier immediately and request an inspection. Be sure to keep the carton, packing inserts, packing lists, and carrier's receipt until the inspector has verified your claim.

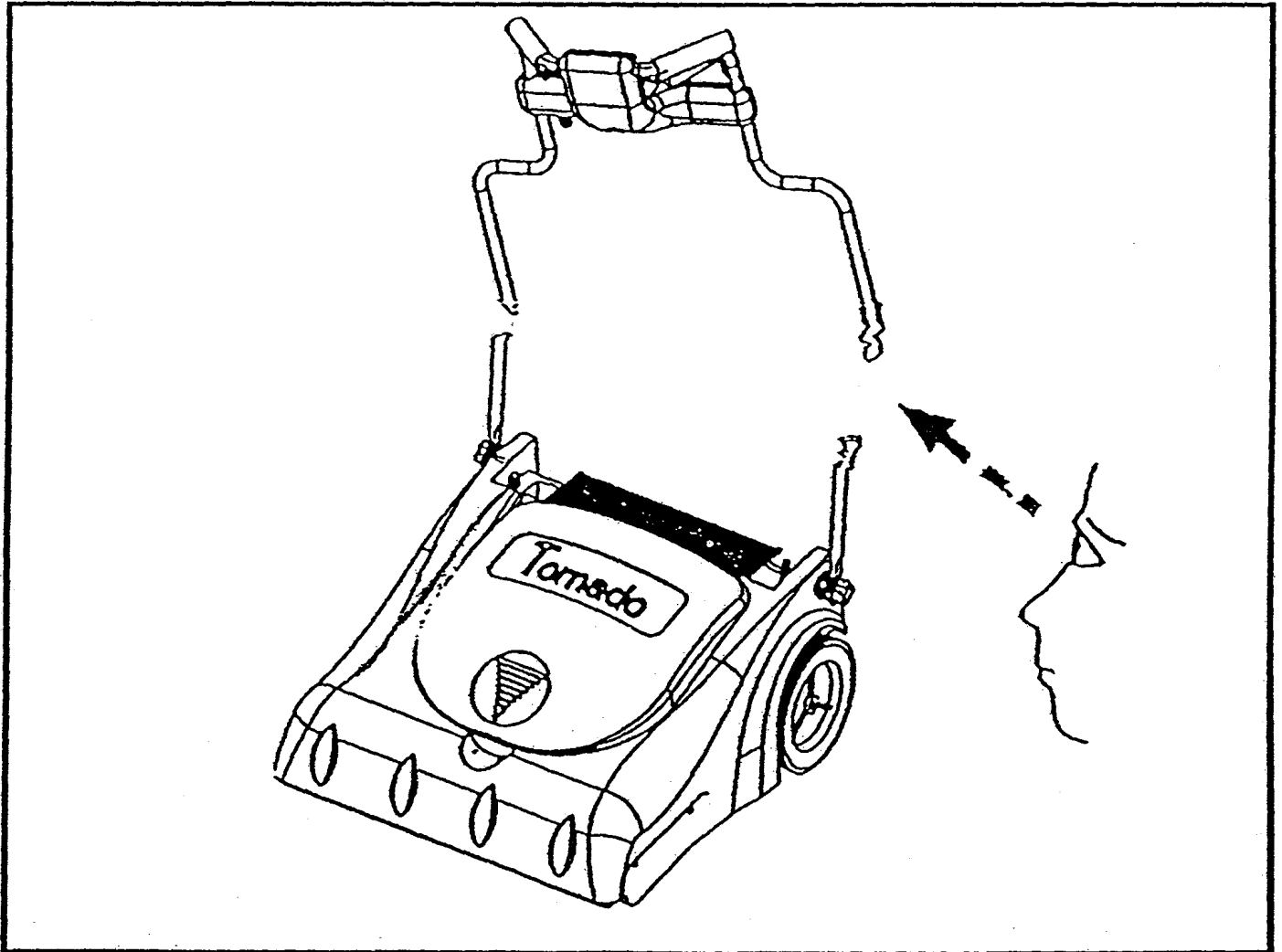
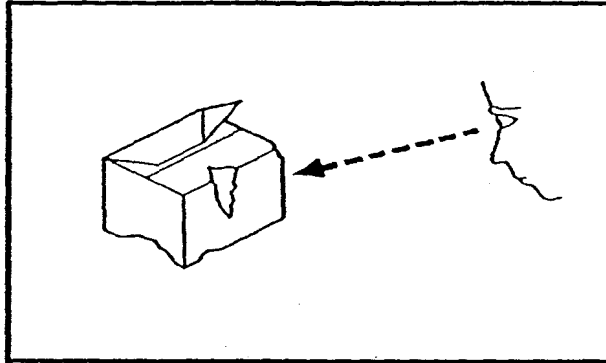

ASSEMBLY INSTRUCTIONS:

1. Loosen handle pivot knobs and adjust handle to comfortable operation height.
2. Tighten knobs to lock handle in place.

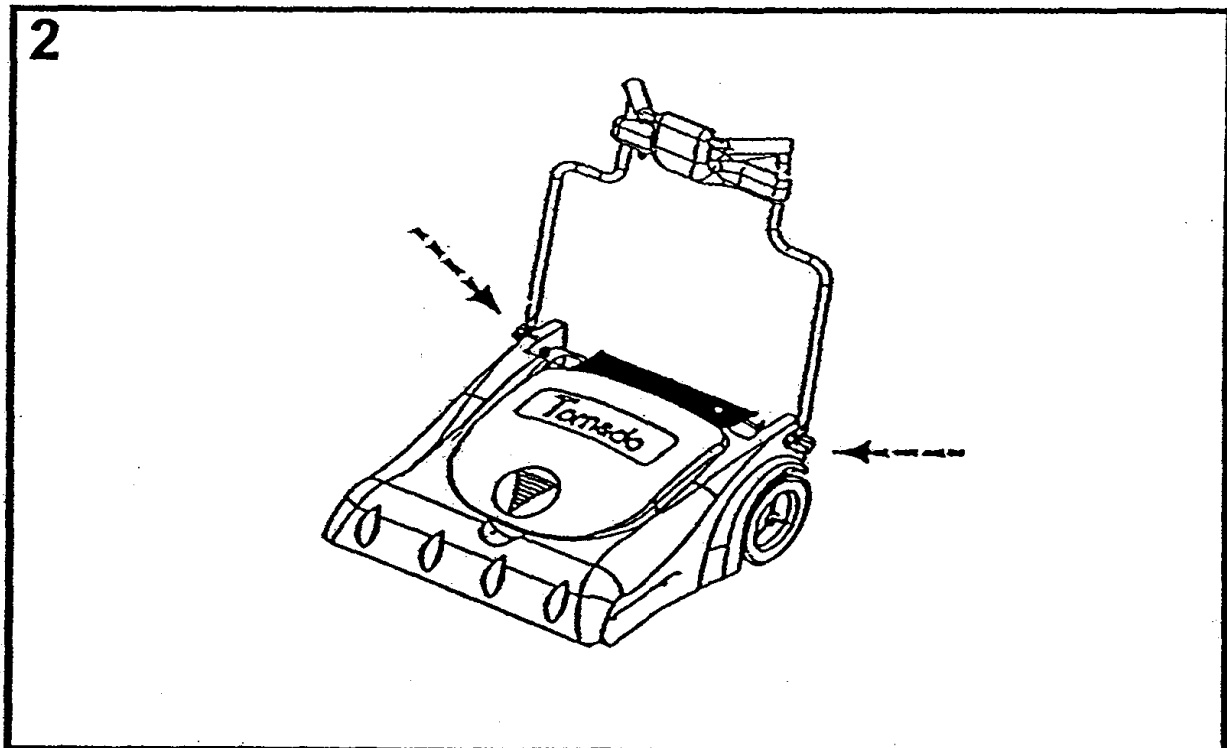
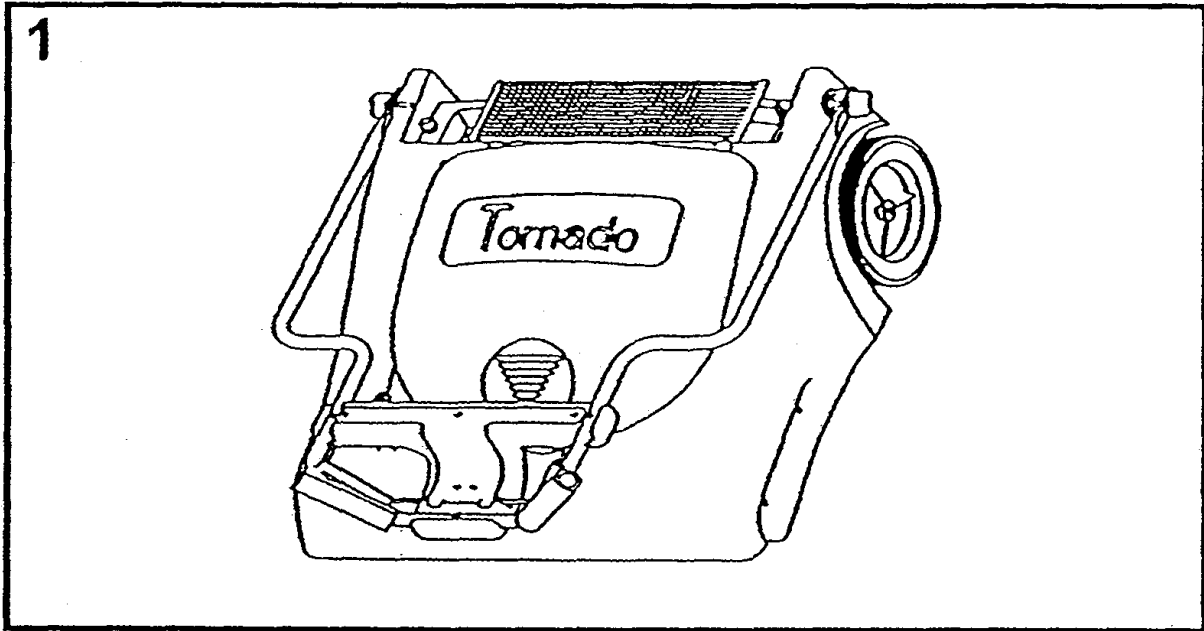

BAG INSTALLATION INSTRUCTIONS:

1. Open Wide Area Vacuum lid.
2. Unzip cloth bag and install paper bag inside.
3. Attach both bag openings together onto vacuum intake housing (see diagram 3 below).
4. Make sure bag is properly deployed inside machine housing.
5. Completely close zipper on cloth bag and close lid of machine.

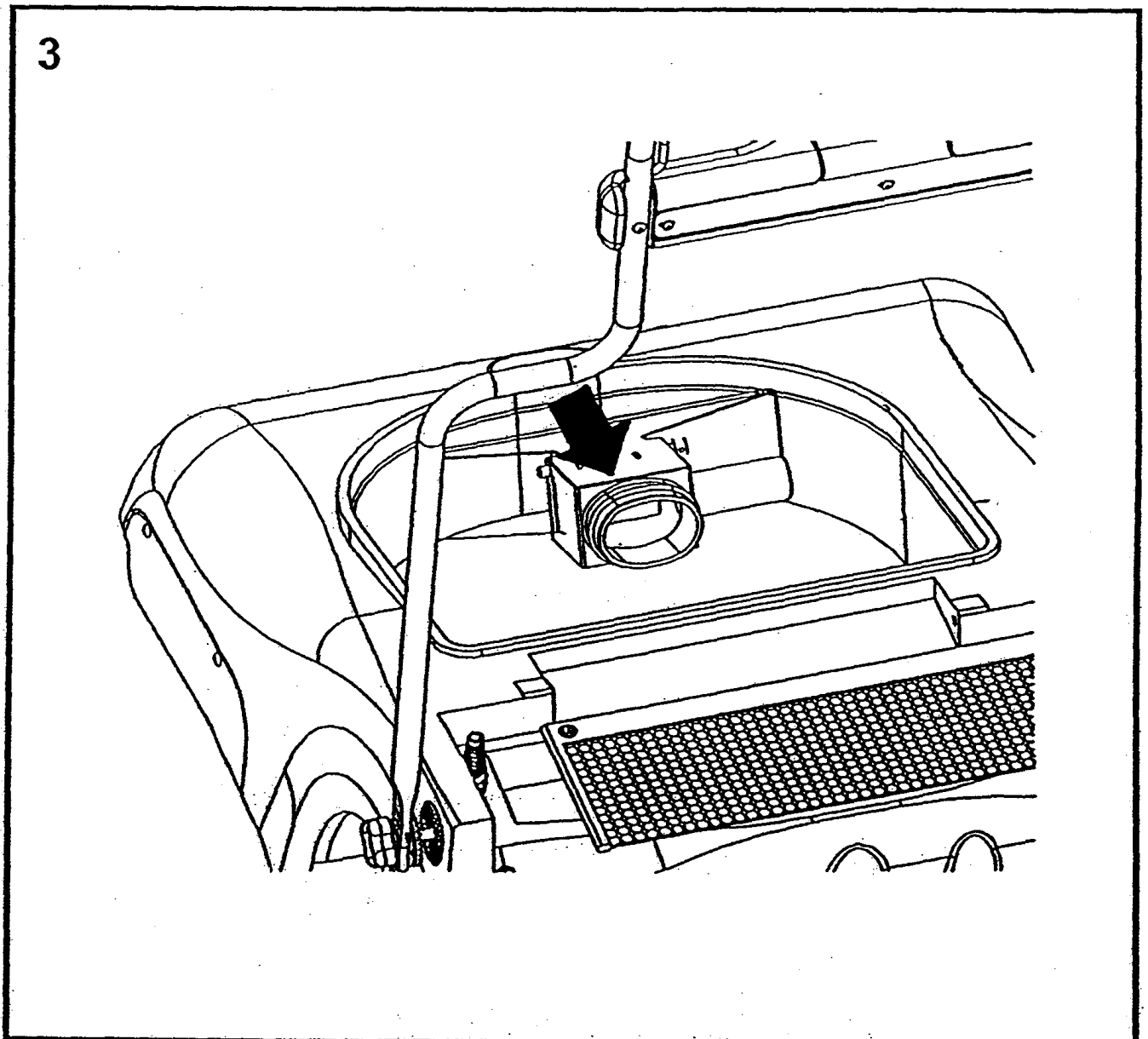

BRUSH HEIGHT ADJUSTMENT:

1. This machine has 5 brush adjustment levels.
2. To raise brush height level: lift up height adjustment bar until desired brush height is attained (see diagram 4 below).
3. To lower brush height level: push down on height adjustment bar until desired brush height is attained (see diagram 5 below).

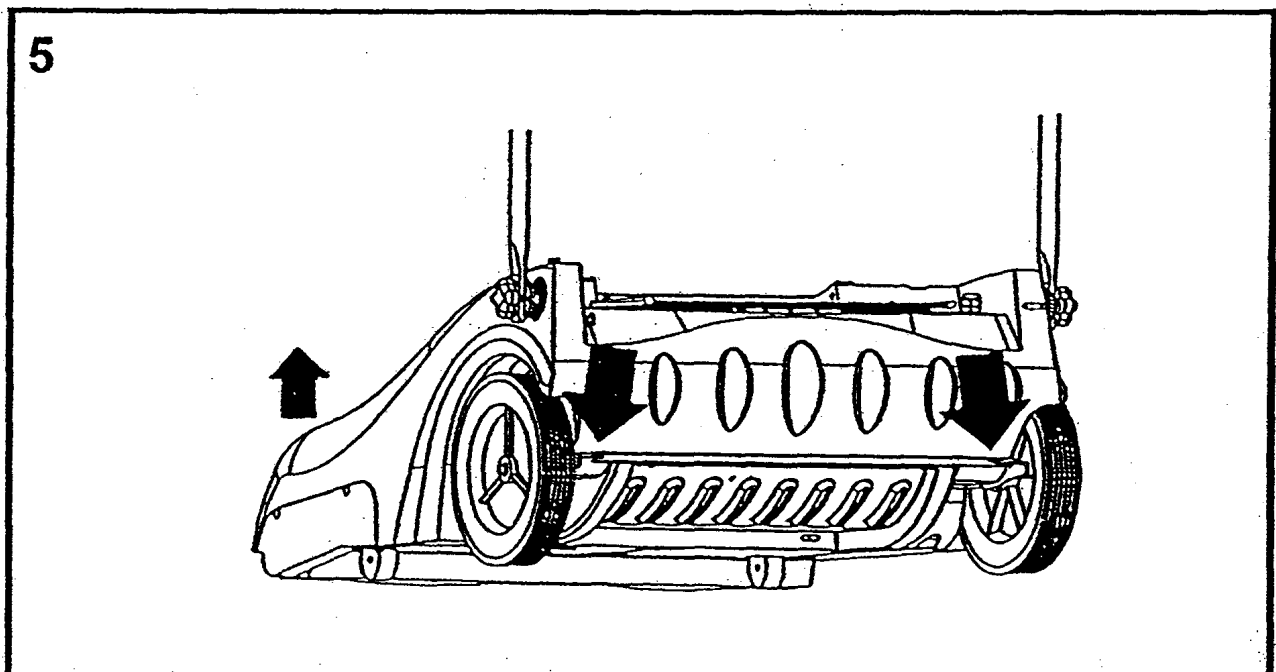
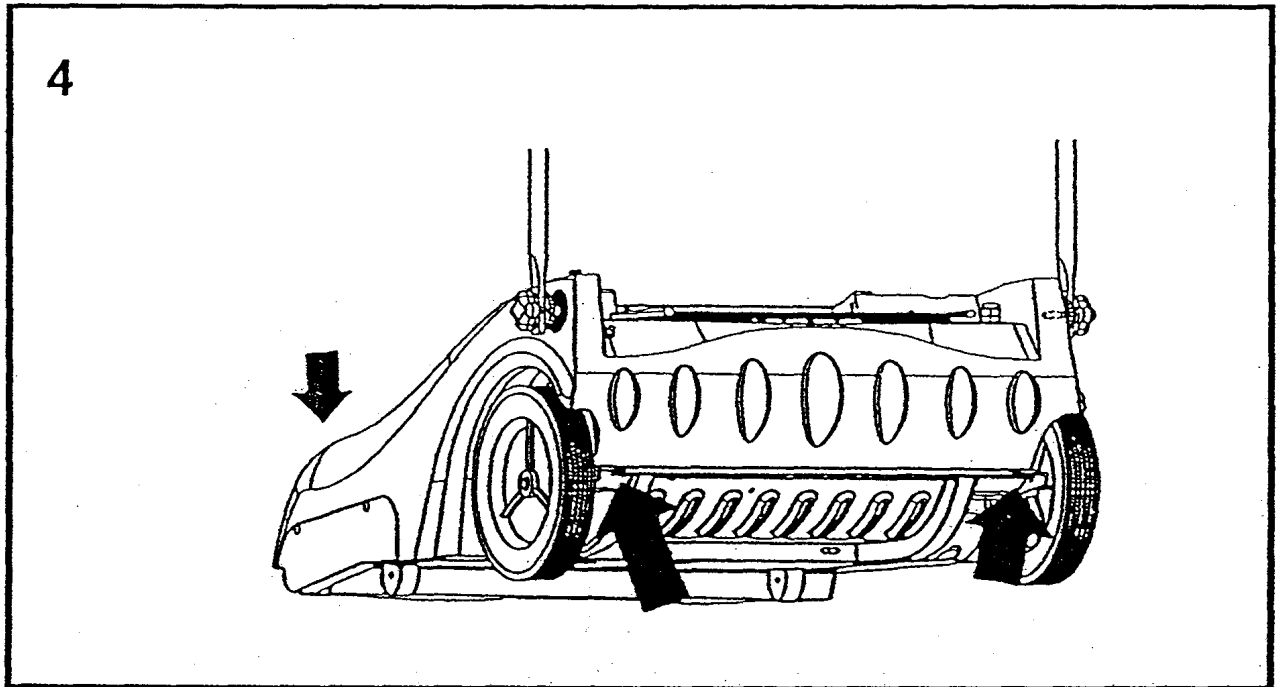

OPERATION OF MACHINE:

1. Depress foot switch (located at rear left of machine) to turn on machine.
2. To operate brush squeeze trigger bar.
3. Adjust height for proper pick-up (refer to height adjustment instructions and diagram 6 below).

6.

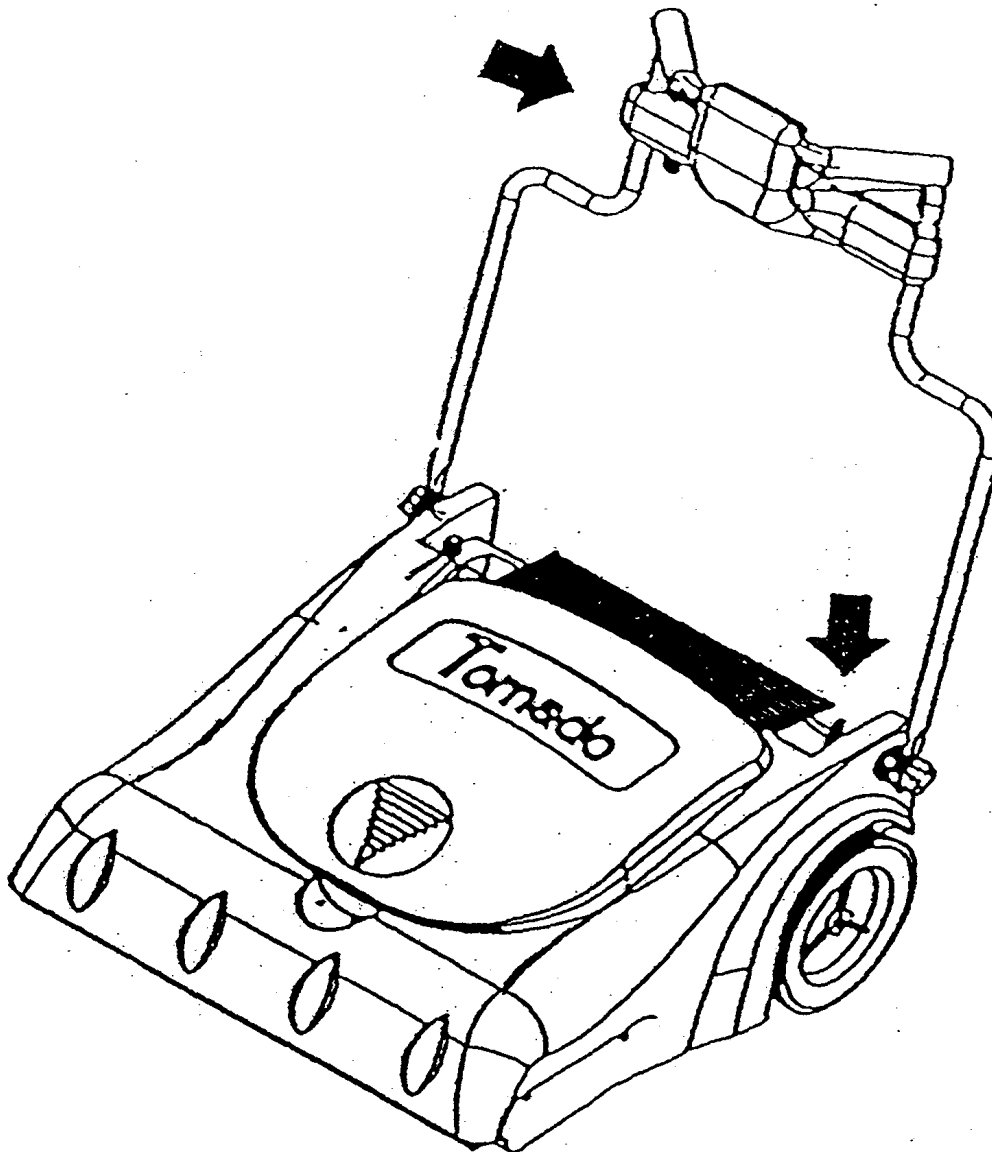

FILTER REPLACEMENT:

1. Remove filter cover screws at back of machine (see diagram 7 below).
2. Remove the two nuts holding filter onto machine.
3. Replace filter in proper position and tighten nuts.
4. Reinstall filter cover.

7.

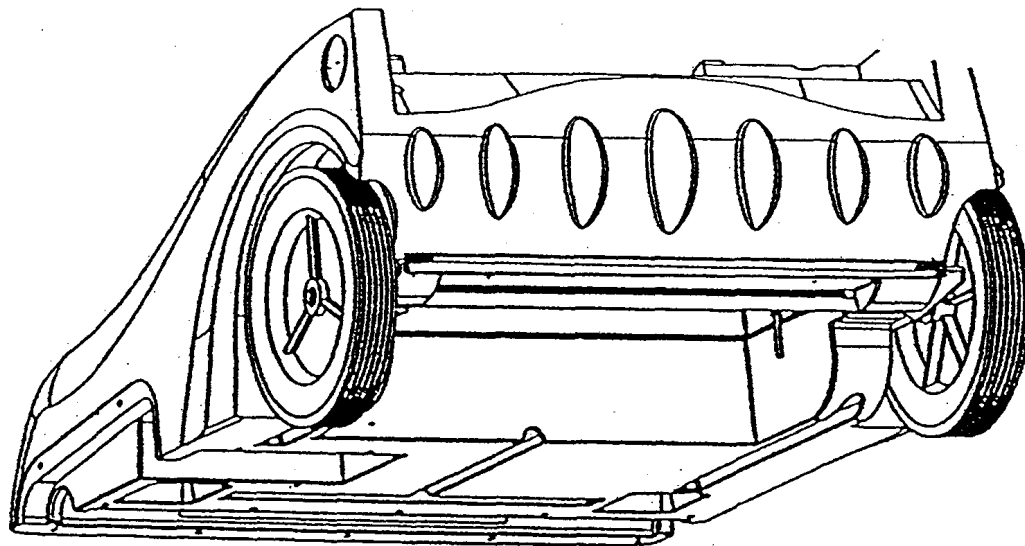

filter

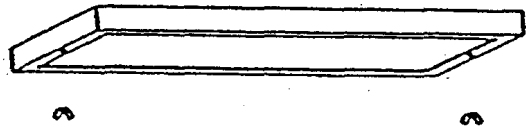

filter cover

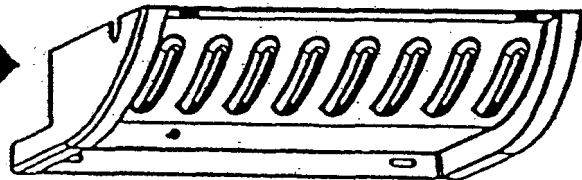

BELT ADJUSTMENT

1. Remove belt cover on left side of machine (refer to diagram).
2. Loosen the two motor belt adjusting screws on motor bracket.
3. Remove belt.
4. Install new belt and reposition motor to eliminate excess slack.
5. Once proper tension is set, tighten motor adjusting screws.
6. Replace belt cover on side of machine.

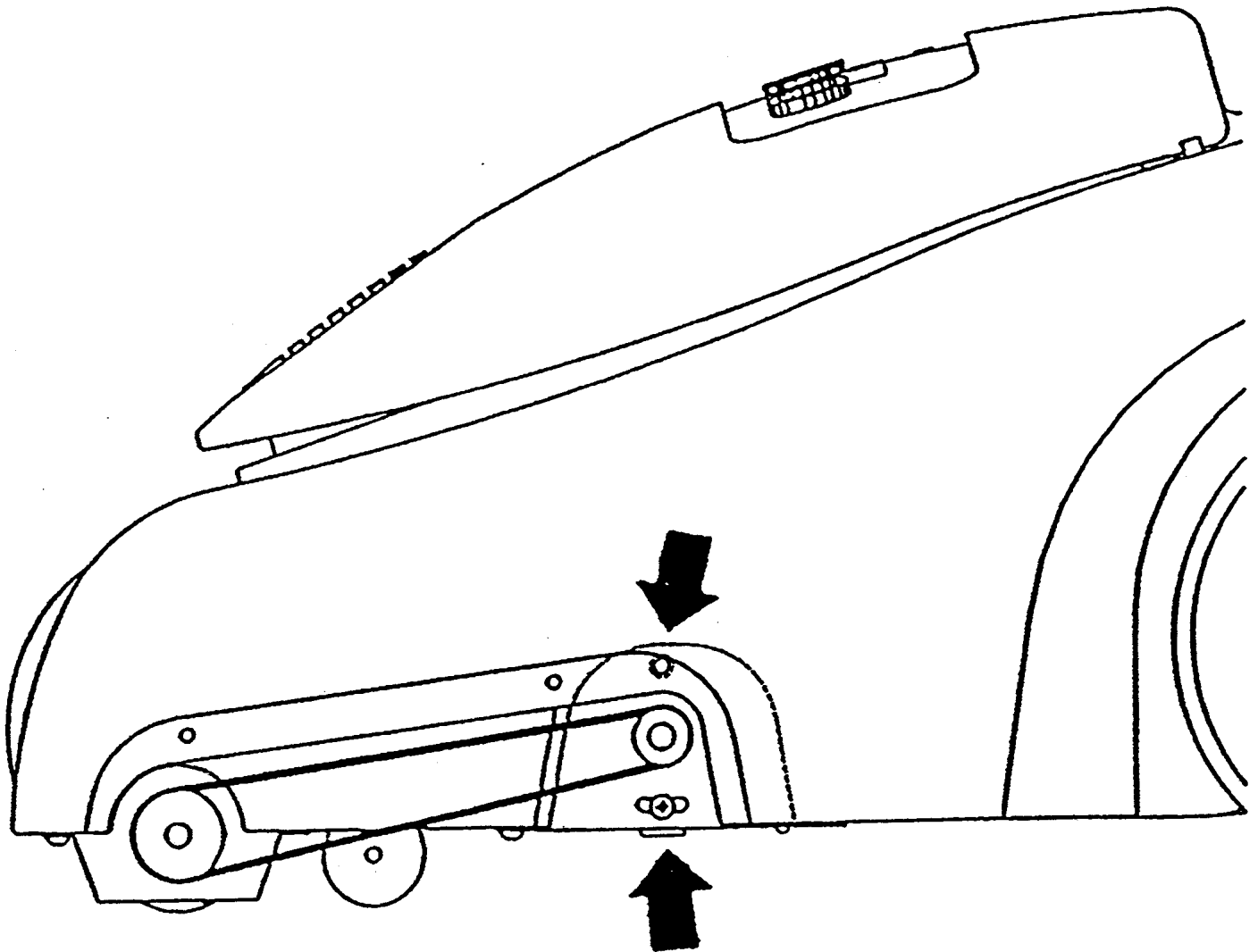

Belt Adjusting Screws

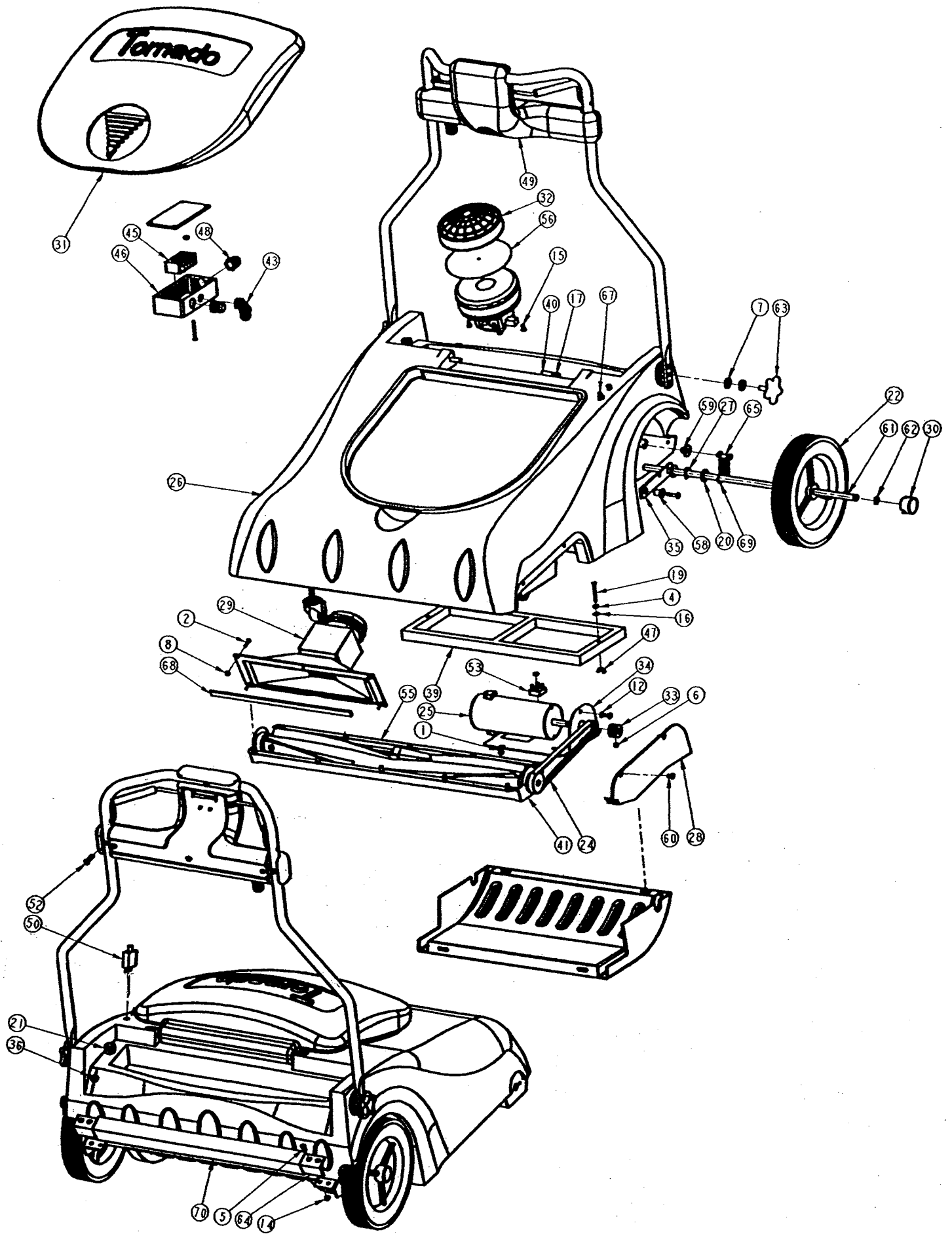

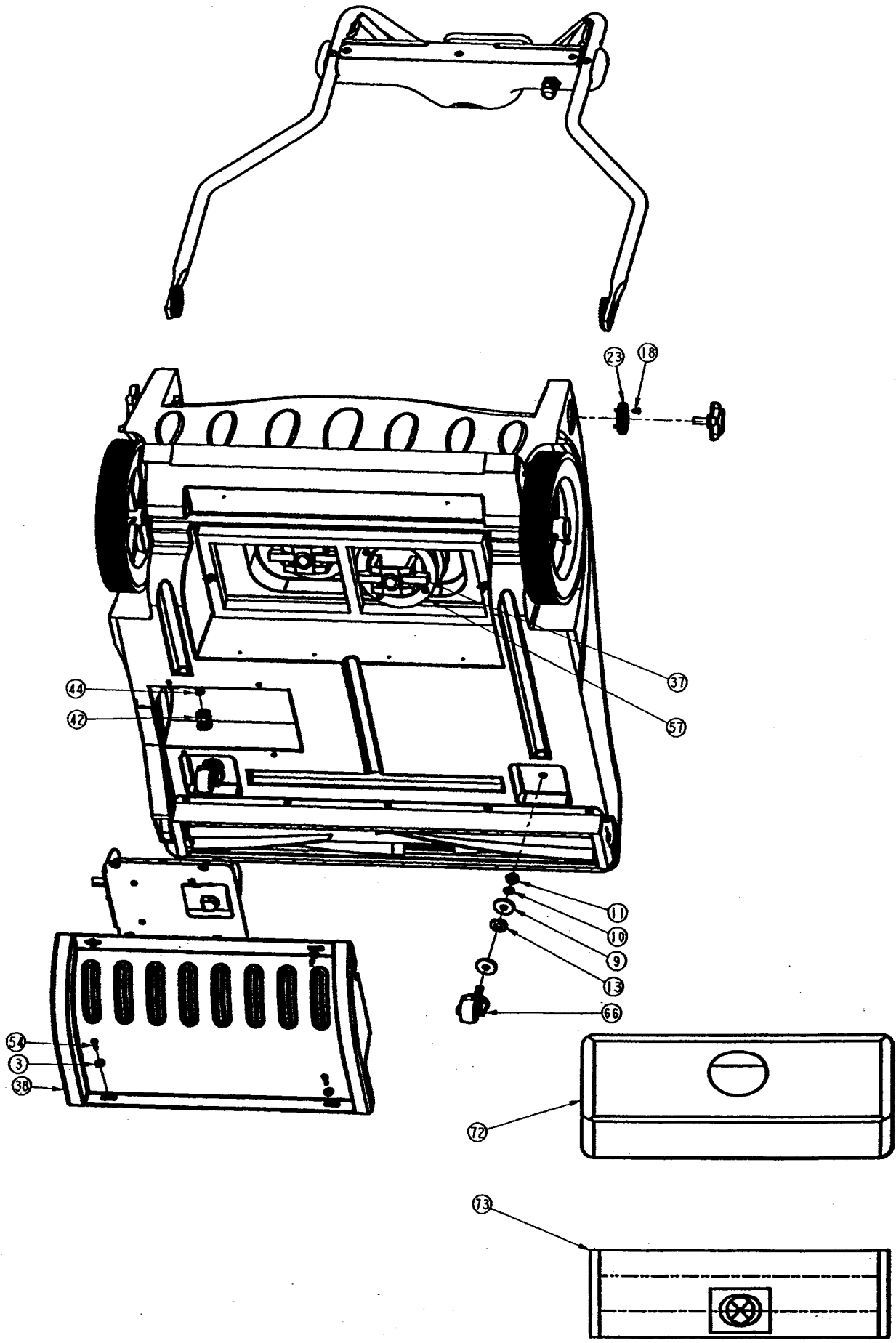

FULL ASSEMBLY PARTS LIST

<u>ITEM</u>	<u>QTY</u>	<u>PART #</u>	<u>DESCRIPTION</u>
1	16	00086	SCREW - PHILLIPS ROUND HEAD MACHINE 1/4-20 X 1/2
2	5	00600	SCREW - SLOTTED ROUND HEAD MACHINE #8-32 X 3/4
3	4	00851	WASHER - PLAIN 1/4
4	4	01604	NUT – FINISHED HEX
5	4	01993	SCREW - PHILLIPS FLAT HEAD MACHINE #10-24 X 3/4
6	1	02011	SET SCREW, BRUSH PULLEY
7	4	02658	WASHER - PLAIN 5/16
8	5	02956	NUT – HEX. LOCK (KEPS) *8-32
9	4	03321	WASHER - PLAIN .391
10	2	03536	WASHER - LOCK 3/8"
11	2	05025	NUT – HEX. LOCK JAM
12	2	07870	WASHER - LOCK (I/T) 1/4"
13	2	10373	WASHER - PLAIN .500
14	4	10894	NUT – HEX. LOCK (P/T)
15	8	11240	SCREW - PHILLIPS PAN HEAD TAPTITE #10-24 X 1/2
16	4	11385	WASHER SEALING
17	2	15357	SPRING - LATCH RELEASE
18	8	19255	SCREW – PHILLIPS FLAT HEAD MACHINE #8-32 X 1/2 (ZP)
19	4	16433	SCREW – PHILLIPS FLAT HEAD MACHINE #10-32 X 1-3/4
20	4	16581	WASHER – PLAIN 1/2"
21	4	18793	STRAIN RELIEF (LIQ.TITE)
22	2	19797	WHEEL 10" PLASTIC HUB 125 LB
23	2	19798	BRACKET GROOVED HANDLE
24	1	19802	BELT, BRUSH DRIVE-POLY
25	1	19803	MOTOR BRUSH DRIVE (115V)
26	1	19814	CHASSIS, MAIN - ROTO MOLDED (93030)
*	1	30872	CHASSIS, MAIN - ROTO MOLDED (93032)
27	2	19818	SPRING, 1/2 CURVED (VEND)
28	1	19819	COVER, BELT ROTO-MOLDED (93030)
*	1	30876	COVER, BELT ROTO-MOLDED (93032)
29	1	19822	INTAKE DUCT (93030)
*	1	30871	INTAKE DUCT (93032)
30	2	19831	HUB CAP, WHEEL WAV
31	1	19832	LID, MOLDED (WAV) (93030)
*	1	30870	LID, MOLDED (WAV) (93032)
32	2	19834	FILTER VAC. MTR. INTAKE
33	1	19835	PULLEY, BRUSH DRIVE MOTOR
34	1	19836	MOUNT, BRUSH MOTOR (STEEL)
35	2	19841	ARM , WHEEL PIVOT - 3/16 X 1
36	1	19850	SWITCH, ON/OFF
37	2	19852	MOTOR VACUUM (115V)
38	1	19854	COVER EXHAUST .13" NOM. THK (93030)
*	1	30875	COVER EXHAUST .13" NOM. THK (93032)
39	1	19855	FILTER, WAV EXHAUST
40	2	19864	PIN, LID HINGE STEEL .340"
41	1	19870	ASS'Y – BRUSH

FULL ASSEMBLY PARTS LIST - CONTINUED

42	1	19875	FITTING STRAIGHT (BLK PLSTC)
43	1	19876	FITTING, ELBOW (FOR CABLE)
44	1	19878	CONDUIT - CABLE 10" LG.
45	1	19879	BLOCK TERMINAL
46	2	19880	BOX - ELECTRICAL
47	1	19975	NUT - WING (10-32) ZINC PL
48	1	19977	STRAIN RELIEF (PLACTIC)
49	1	19984	ASS'Y HANDLE (93030)
*	1	30873	ASS'Y HANDLE (93032)
50	1	19990	CIRCUIT BREAKER
51	2	19991	BOOT, RUBBER – ELECTRICAL CONNECT
52	1	19999	SCREW - PHILLIPS ROUND HEAD MACHINE 1/4-20 X 1-1/8
53	4	24185	RECTIFIER 60 AMP
54	1	30018	SCREW - THUMB W/ SHOULDER #10-32 X 1/2"
55	2	30077	GASKET - SHOE (POLY FOAM)
56	2	30088	FILTER - PRE
57	2	30089	GASKET - MOTOR (POLY FOAM)
58	2	30461	SLEEVE PIVOT .5"(.25"ID)
59	2	30464	SLEEVE PIVOT (LRG).312"ID
60	1	30467	SCREW - PHIL. FLAT HD MACH
61	2	30491	ASS'Y AXLE WHEEL
62	2	30507	SNAP RING 1/2" EXTERNAL
63	1	30558	KNOB - HANDLE ADJ.(BLACK)
64	2	30595	PEDAL - FOOT ADJ. (STEEL)
65	2	30617	SCREW - SOCKET HD SHOULDER 5/16 DIA. X 1-1/2"
66	1	31209	WHEEL, CASTER
67	1	31236	CIRCUIT BREAKER, 3 AMPS
68	2	80605	GASKET MAT'L – NEOPRENE
69	1	30466	SPRING TENSION
70	1	30596	COVER PEDAL
71	1	19473	CORD - POWER (115V) 14/3 75' (MALE PLUG) YELLOW
72	1	19816	BAG, CLOTH
73	4	90701	BAG – PAPER, DISPOS – 10 PACK
(74)	1	18706	WIRE TIES 15" BLACK
(75)	1	30008	DECAL, WIRING
(76)	1	30017	WIRING HARNESS – MAIN BODY
(77)	1	30078	GASKET - HOOD 54" (L-200)

() ITEMS NOT SHOWN

* ITEM TO BE USED WHERE APPLICABLE

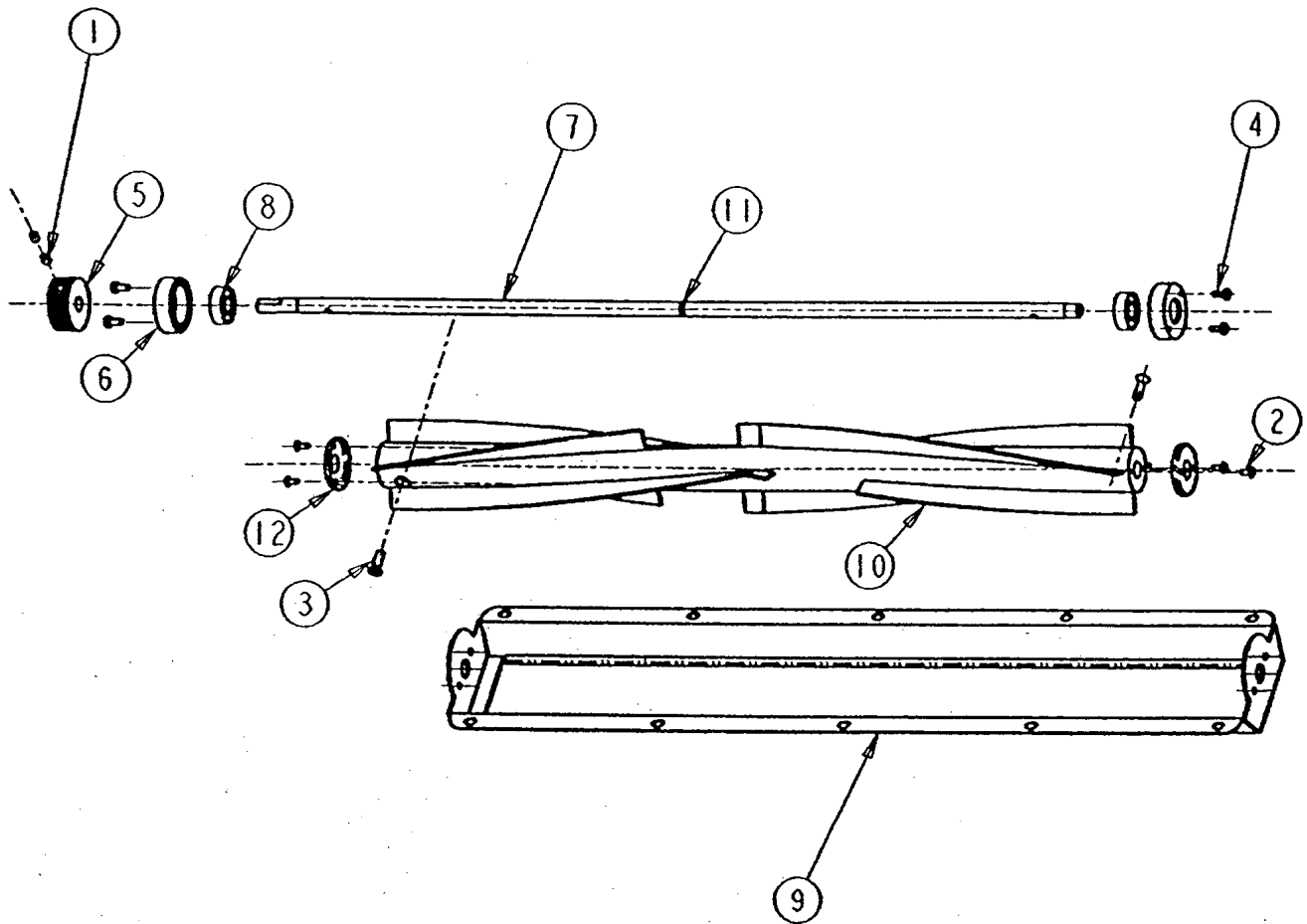

BRUSH ASSEMBLY PARTS LIST

(REF. DRAWING 19870)

<u>ITEM</u>	<u>QTY</u>	<u>PART #</u>	<u>DESCRIPTION</u>
1	2	02011	SET SCREW, BRUSH PULLEY
2	4	07535	SCREW #8-15 X .50 LG. (SHEET METAL)
3	2	11276	SCREW 1/4-20 X 7/8" LG. FLAT HEAD
4	4	16142	SCREW #10-32 X 1/2" LG. PAN HD (PHIL)
5	1	19804	BRUSH PULLEY
6	2	19805	BLOCK, BRUSH BEARING
7	1	19808	AXLE, WAV BRUSH
8	2	19809	BEARING, WAV BRUSH
9	1	19810	SHOE, WAV BRUSH MOUNT
10	1	19811	BRUSH 20" WAV
11	1	19838	"O" RING
12	2	19848	THREAD GUARD

HANDLE ASSEMBLY
(DRWG. P/N 30873)

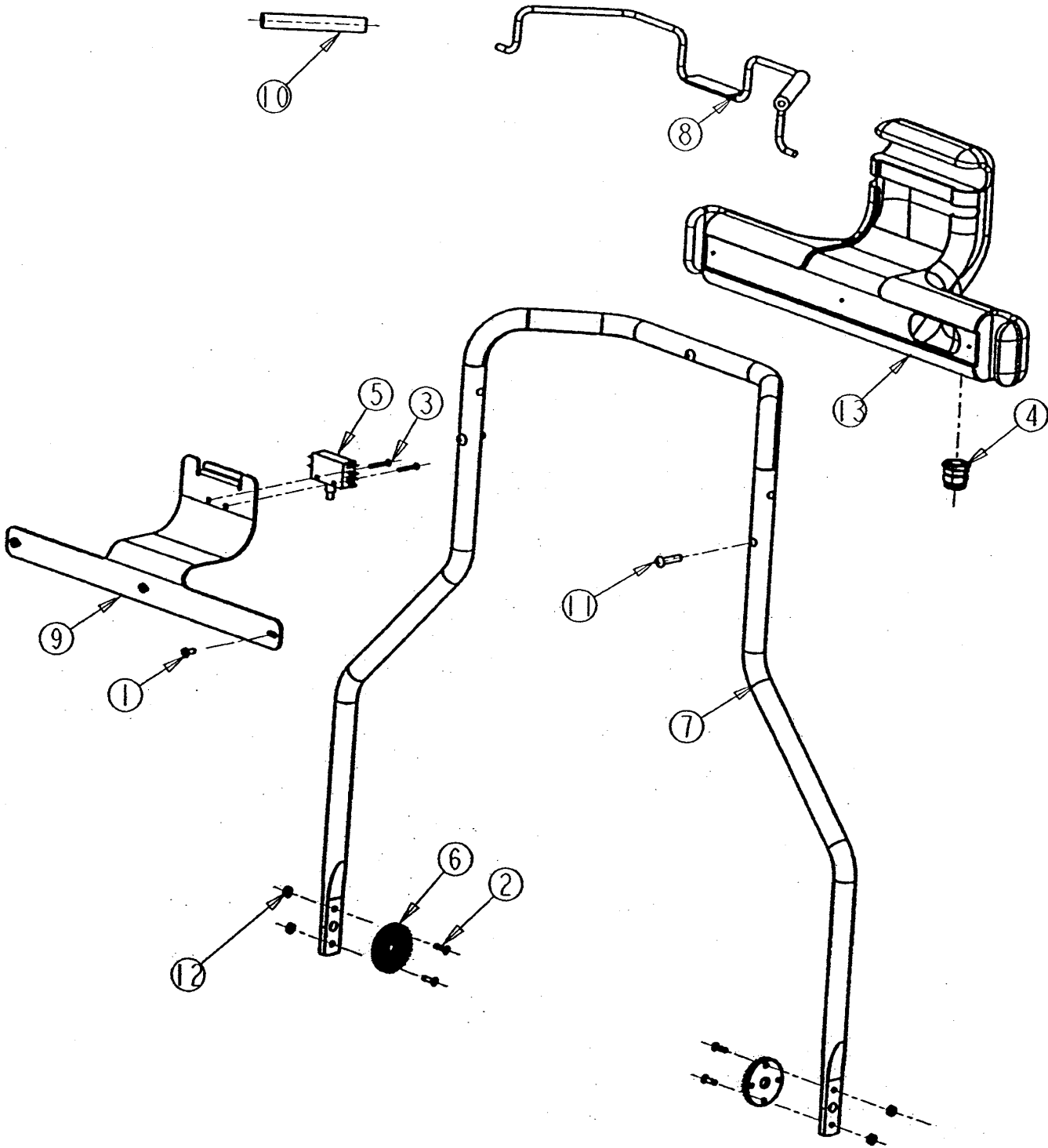

HANDLE ASSEMBLY PARTS LIST

(REF. DRAWING 30873)

<u>ITEM</u>	<u>QTY</u>	<u>PART #</u>	<u>DESCRIPTION</u>
1	3	03660	#10-24 X 7/16" PAN HEAD SCREW
2	4	05769	#8-32 X 5/8" FLAT HEAD SCREW
3	2	06686	#6-32 X 3/4" PAN HEAD SCREW
4	1	18793	STRAIN RELIEF, CONTROL PANEL
5	1	19357	SWITCH, BRUSH
6	2	19798	BRACKET, HANDLE ADJUSTMENT
7	1	19829	HANDLE, MAIN STEEL TUBE
8	1	19849	TRIGGER, BRUSH SWITCH
9	1	19869	COVER, CONTROL PANEL
10	2	19971	FOAM GRIP TRIGGER
11	3	19999	1/4-20 X 1-1/8" ROUND HEAD SCREW
12	4	30074	HEX NUT LOCK
13	1	30874	CONTROL PANEL, WAV (93032)
*	1	19813	CONTROL PANEL, WAV (93030)
(14)	1	19996	WIRE HARNESS

* ITEMS TO BE USED WHERE APPLICABLE

() ITEMS NOT SHOWN

WIRING DIAGRAM

Wide Area Vacuum
(Ref. Drawing #30008)

