

chariot

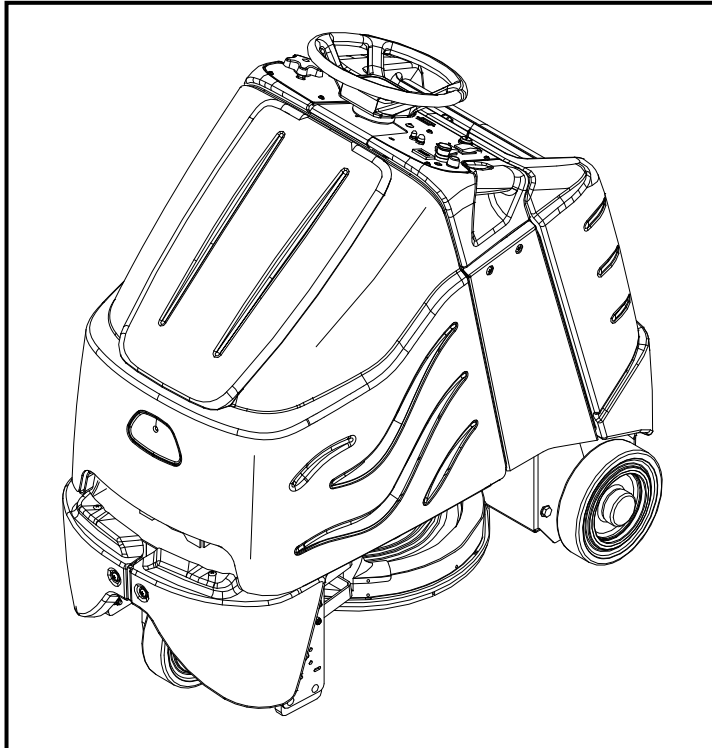

iGLOSS

Operating Instructions (ENG)



FROM SERIAL #10020080000118

MODELS: CB20 CBCD20
 10020080 10020160

CBE20
 10020100

Read these instructions before using the machine.



MACHINE DATA LOG/OVERVIEW

MODEL _____
DATE OF PURCHASE _____
SERIAL NUMBER _____
SALES REPRESENTATIVE # _____

YOUR DEALER
Name: _____
Address: _____
Phone Number: _____

OVERVIEW

The Chariot burnisher is a battery powered, ride-on, hard floor burnisher intended for commercial use. The appliance applies a high luster to hard floor surfaces.

TABLE OF CONTENTS

<i>Machine Data Log/Overview</i>	2
<i>Table Of Contents</i>	3

HOW TO USE THIS MANUAL

<i>How To Use This Manual</i>	1-1
-------------------------------------	-----

SAFETY

<i>Important Safety Instructions</i>	2-1
<i>Hazard Intensity Level</i>	2-2
<i>Safety Label Location</i>	2-3

OPERATIONS

<i>Technical Specifications</i>	3-1
<i>How The Machine Works</i>	3-3
<i>Components</i>	3-4
<i>Drive Controls</i>	3-5
<i>Burnisher Controls</i>	3-9

<i>Machine Operation</i>	3-11
<i>Pre-Run Machine Inspection</i>	3-11
<i>Starting Machine</i>	3-11
<i>Operating The Machine</i>	3-11
<i>Emergency Stop Procedures</i>	3-11
<i>To Begin Burnishing</i>	3-12

MAINTENANCE

<i>Service Schedule</i>	4-1
<i>Batteries</i>	4-2
<i>Dust Bag Replacement</i>	4-7
<i>Pad Installation</i>	4-7
<i>Pad Driver Replacement</i>	4-8
<i>Shunt Adjustment</i>	4-10
<i>Drive Motor & Brake</i>	4-11
<i>Circuit Protection</i>	4-14
<i>Troubleshooting</i>	4-15

GROUP PARTS LIST

<i>Bumper</i>	5-1
<i>Control Panel</i>	5-3
<i>Controls & Housing</i>	5-5
<i>Decal</i>	5-7
<i>Filter</i>	5-9
<i>Frame-Lower</i>	5-11
<i>Frame-Upper</i>	5-13
<i>Hood</i>	5-15
<i>Pedal Platform (From SN)</i>	5-17A-B
<i>Pedal Platform (To SN)</i>	5-18A-B
<i>Rear Cover</i>	5-21
<i>Deck Lift Mechanism</i>	5-23
<i>Deck Lift Linkage</i>	5-25
<i>Steering</i>	5-27
<i>Wheel-Front Drive, Chain</i>	5-29
<i>Wheel-Front Brake</i>	5-31
<i>Wheel-Front Drive, Gear</i>	5-33
<i>Wheel-Rear</i>	5-35
<i>Wiring-Batteries</i>	5-37
<i>Wiring-Components</i>	5-39
<i>Wiring-Control Panel</i>	5-41
<i>Wiring-Drive Motor</i>	5-43
<i>Wiring-Main Harness</i>	5-45
<i>Wiring-Pedal Platform (From SN)</i>	5-47A-B
<i>Wiring-Pedal Platform (To SN)</i>	5-48A-B
<i>Wiring Diagram</i>	5-49
<i>Suggested Spare Parts</i>	5-50
<i>Back-Up Alarm – Option</i>	5-51
<i>Battery Cart – Option</i>	5-53
<i>Seat – Option</i>	5-57
<i>Warning Light – Option</i>	5-59
<i>EC Declaration</i>	5-61
<i>Serial numbers</i>	5-62
<i>Warranty</i>	

HOW TO USE THIS MANUAL

This manual contains the following sections:

- HOW TO USE THIS MANUAL
- SAFETY
- OPERATIONS
- MAINTENANCE
- PARTS LIST

The HOW TO USE THIS MANUAL section will tell you how to find important information for ordering correct repair parts.

Parts may be ordered from authorized Windsor dealers. When placing an order for parts, the machine model and machine serial number are important. Refer to the MACHINE DATA box which is filled out during the installation of your machine. The MACHINE DATA box is located on the inside of the front cover of this manual.

MODEL _____
DATE OF PURCHASE _____
SERIAL NUMBER _____
SALES REPRESENTATIVE # _____

The model and serial number of your machine are located below the battery compartment of the machine.

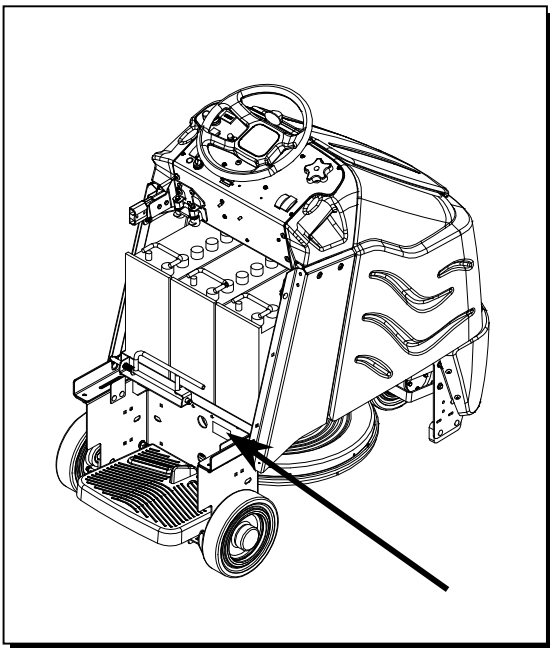

The SAFETY section contains important information regarding hazard or unsafe practices of the machine. Levels of hazards are identified that could result in product or personal injury, or severe injury resulting in death.

The OPERATIONS section is to familiarize the operator with the operation and function of the machine.

The MAINTENANCE section contains preventive maintenance to keep the machine and its components in good working condition. They are listed in this general order:

- Batteries
- Maintenance
- Shunt Adjustment
- Drive Motor & brake
- Circuit Protection
- Machine Troubleshooting

The PARTS LIST section contains assembled parts illustrations and corresponding parts list. The parts lists include a number of columns of information:

- **REF** – column refers to the reference number on the parts illustration.
- **PART NO.** – column lists the part number for the part.
- **PRV NO.** – reference number.
- **QTY** – column lists the quantity of the part used in that area of the machine.
- **DESCRIPTION** – column is a brief description of the part.
- **SERIAL NO. FROM** – column indicates the first machine the part number is applicable to. When the machine design has changed, this column will indicate serial number of applicable machine. The main illustration shows the most current design of the machine. The boxed illustrations show older designs. If column has an asterisk (*), call manufacturer for serial number.
- **NOTES** – column for information not noted by the other columns.

NOTE: If a service or option kit is installed on your machine, be sure to keep the KIT INSTRUCTIONS which came with the kit. It contains replacement parts numbers needed for ordering future parts.

IMPORTANT SAFETY INSTRUCTIONS

When using an battery powered appliance, basic precaution must always be followed, including the following:

READ ALL INSTRUCTIONS BEFORE USING THIS MACHINE.



To reduce the risk of fire, electric shock, or injury:

Use only indoors. Do not use outdoors or expose to rain.

Use only as described in this manual. Use only manufacturer's recommended components and attachments.

If the machine is **not working properly**, has been dropped, damaged, left outdoors, or dropped into water, return it to an authorized service center.

Do not operate the machine with any openings blocked. Keep openings free of debris that may reduce airflow.

This machine **is not** suitable for picking up hazardous dust.

Machine can cause a fire when operating near flammable vapors or materials. Do not operate this machine near flammable fluids, dust or vapors.

This machine is suitable for commercial use, for example in hotels, schools, hospitals, factories, shops and offices for more than normal housekeeping purposes.

Maintenance and repairs **must be done** by qualified personnel.

Disconnect battery before cleaning or servicing.

Before the machine is discarded, the batteries **must be removed** and properly disposed of.

Make sure all warning and caution labels **are legible and properly attached** to the machine.

During operation, attention shall be paid to other persons, especially children.

Before use all covers and doors shall be put in the positions specified in the instructions.

When leaving unattended, secure against unintentional movement.

The machine shall only be operated by instructed and authorized persons.

When leaving unattended, switch off or lock the main power switch to prevent unauthorized use.

This appliance has been designed for use with the high speed burnishing pads intended for wax finishes. The fitting of other pads may affect its safety.

Do not use on surfaces having a gradient of over 10% (6 degrees).

SAVE THESE INSTRUCTIONS

HAZARD INTENSITY LEVEL

The following symbols are used throughout this guide as indicated in their descriptions:

HAZARD INTENSITY LEVEL

There are three levels of hazard intensity identified by signal words -**WARNING** and **CAUTION** and **FOR SAFETY**. The level of hazard intensity is determined by the following definitions:



WARNING - Hazards or unsafe practices which COULD result in severe personal injury or death.



CAUTION - Hazards or unsafe practices which could result in minor personal injury or product or property damage.

FOR SAFETY: To Identify actions which must be followed for safe operation of equipment.

Report machine damage or faulty operation immediately. Do not use the machine if it is not in proper operating condition. Following is information that signals some potentially dangerous conditions to the operator or the equipment. Read this information carefully. Know when these conditions can exist. Locate all safety devices on the machine. Please take the necessary steps to train the machine operating personnel.

FOR SAFETY:

DO NOT OPERATE MACHINE:

Unless Trained and Authorized.

Unless Operation Guide is Read and understood.

In Flammable or Explosive areas.

In areas with possible falling objects.

WHEN SERVICING MACHINE:

Avoid moving parts. Do not wear loose clothing; jackets, shirts, or sleeves when working on the machine. Use Windsor approved replacement parts.



Batteries emit hydrogen gas. Explosion or fire can result. Keep sparks and open flame away. Keep solution tank in raised position when charging. Keep sparks and flames away from the batteries. Do not smoke around batteries.



Disconnect batteries before working on machine. Only qualified personnel should work inside machine. Always wear eye protection and protective clothing when working on or near batteries. Avoid skin contact with the acid contained in the batteries.



Never allow metal to lie across battery tops.

SAFETY LABEL LOCATION

NOTE: These drawings indicate the location of safety labels on the machine. If at any time the labels become illegible, promptly replace them.

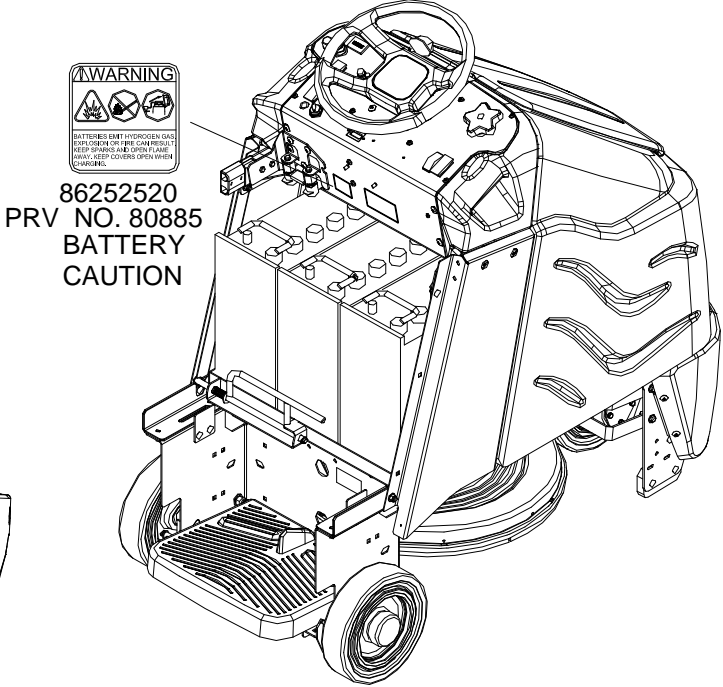
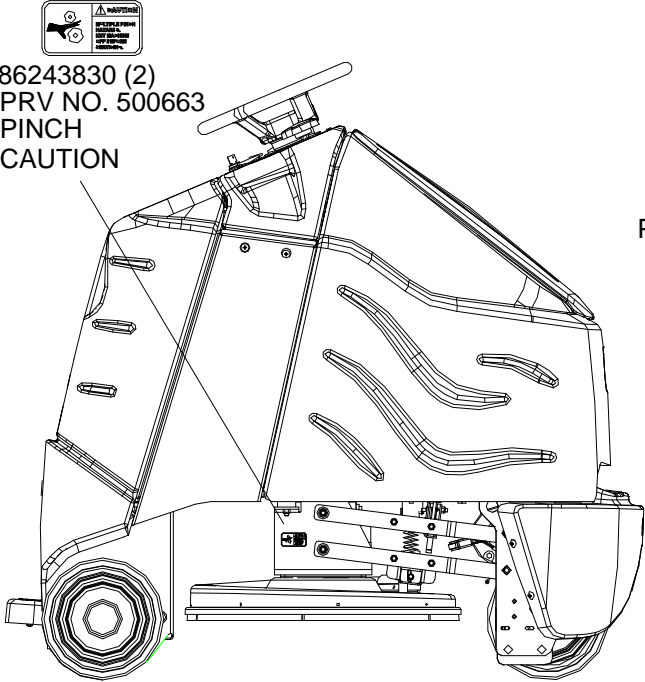
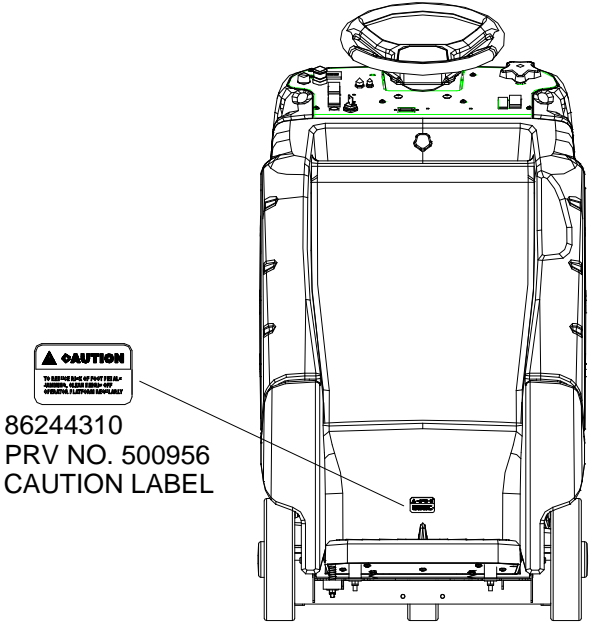

TECHNICAL SPECIFICATIONS

ITEM	DIMENSION/CAPACITY
Nominal power	3450 W
Rated Voltage	36 Volts DC
Rated Amperage	95 amps
Batteries	3 X12 Volt 195-215 AH @ 20 hr. rate
Battery Compartment Dimensions	21 in. x 16 in. x 17 in. tall (533mm x 406mm x 432mm)
Propelling Motor	.75 HP (560 W)
Mass (GVW)	1,001 lbs (455 kg)
Weight empty without batteries	635 lbs (288 kg)
Tires	10" (254mm) Solid gray non-marking
Maximum Speed	3.5 miles/hour (5.6 Km/hour)
Frame Construction	Powder coated steel
Brake	Electrical parking brake, sets automatically whenever operator steps off platform or engages emergency stop.
Minimum aisle u-turn width	56 in. (1425 mm)
Maximum rated climb and descent angle	7.5 degrees

TECHNICAL SPECIFICATIONS

ITEM	MEASURE
Height	50.6 inches (1285 mm)
Length	52.5 inches (1330 mm)
Width	26.5 inches (670 mm)
Width of Burnishing Path	20 inches (508mm)

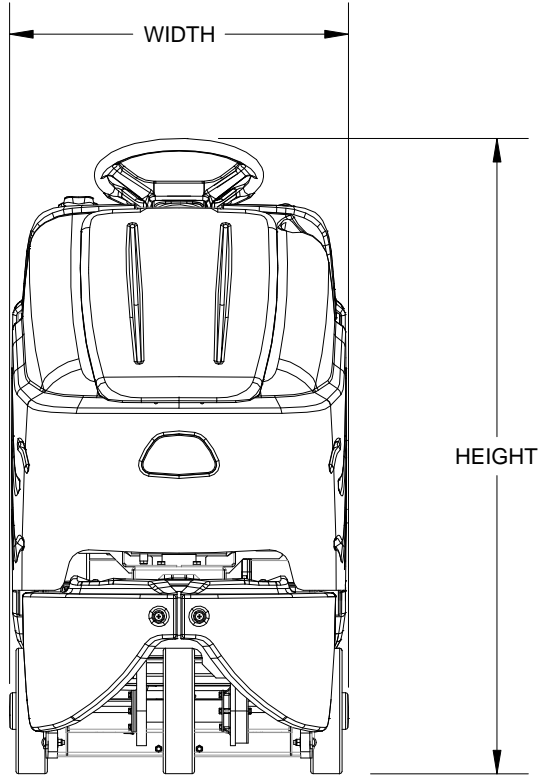
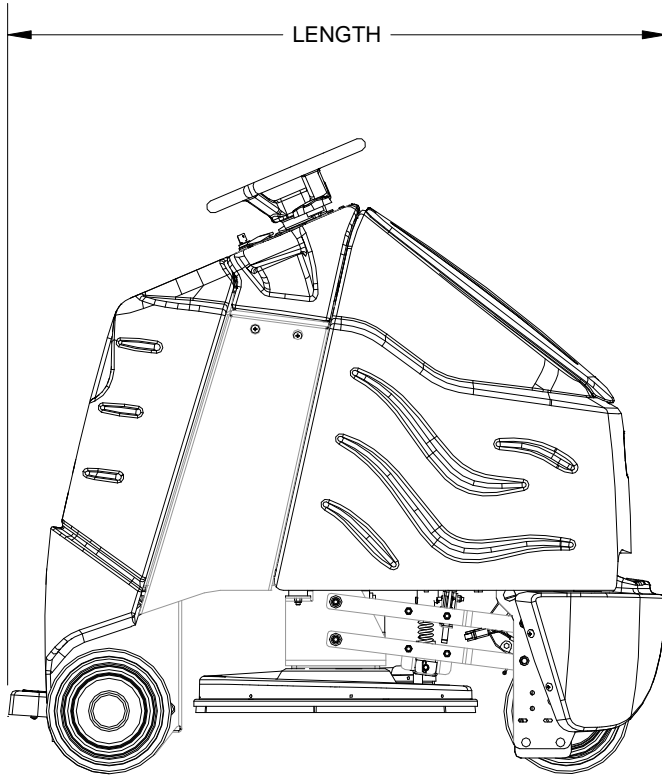

SPECIAL NOTES:

The sound pressure level at the operator's ear was measured to be 64 dBA. This was a nearfield, broad-band measurement taken in a typical industrial environment on a tile floor. This appliance contains no possible source of impact noise. The instantaneous sound pressure level is below 63 Pa.

The weighted root mean square acceleration at the operator's arms was measured to be below 2.5m/s^2 . This was a tri-axial, third-octave-band measurement made during normal operation on a composite tile floor. The measurement and related calculations were made in accordance with ANSI S3.34-1986.

HOW THIS MACHINE WORKS

The Chariot is a battery powered, self propelled, hard floor burnisher intended for commercial use. The appliance spins a high-speed burnishing pad in contact with the floor surface to produce a high luster shine.

The machines primary systems are the burnishing system, the dust control system and the operator control system.

The function of the burnishing system is to spin a high-speed burnishing pad in contact with a floor surface that has had a burnishable floor finish applied. The burnishing pad can be lowered to the floor and raised by the operator, the operator can also control the pad pressure by use of the control knob. The burnishing pad will spin only when the machine is directed to move by the operator.

The function of the dust control system is to collect the dust that is created during the burnishing process. It is normal for a portion of the floor finish to be removed in the form of dust during the process. While burnishing, air movement is created within the burnishing head by the spinning pad. The dust that is also created is entrained in the air stream and transported to a filter bag where it is collected and separated from the air stream. The filter bag can be easily changed without releasing the collected dust.

The function of the operator control system is to control the direction and speed of the machine. The directional control system consists of the direction control switch, throttle pedal, speed control switch, drive reset switch, emergency stop/brake switch, steering wheel, propel controller, drive wheel and operator presence pedal prior to Serial Number (4*). The directional control switch signals forward or reverse direction. The controller interprets signals from the throttle pedal to command the drive wheel to propel or slow the machine. The drive reset switch is to make sure the operator is on platform before machine will propel. The steering wheel points the drive wheel in the direction desired by the operator. The parking brake automatically engages when the operator steps off the platform. The emergency stop/brake can be used to hold the machine on slopes.

*SEE SERIAL NUMBER PAGE.

COMPONENTS

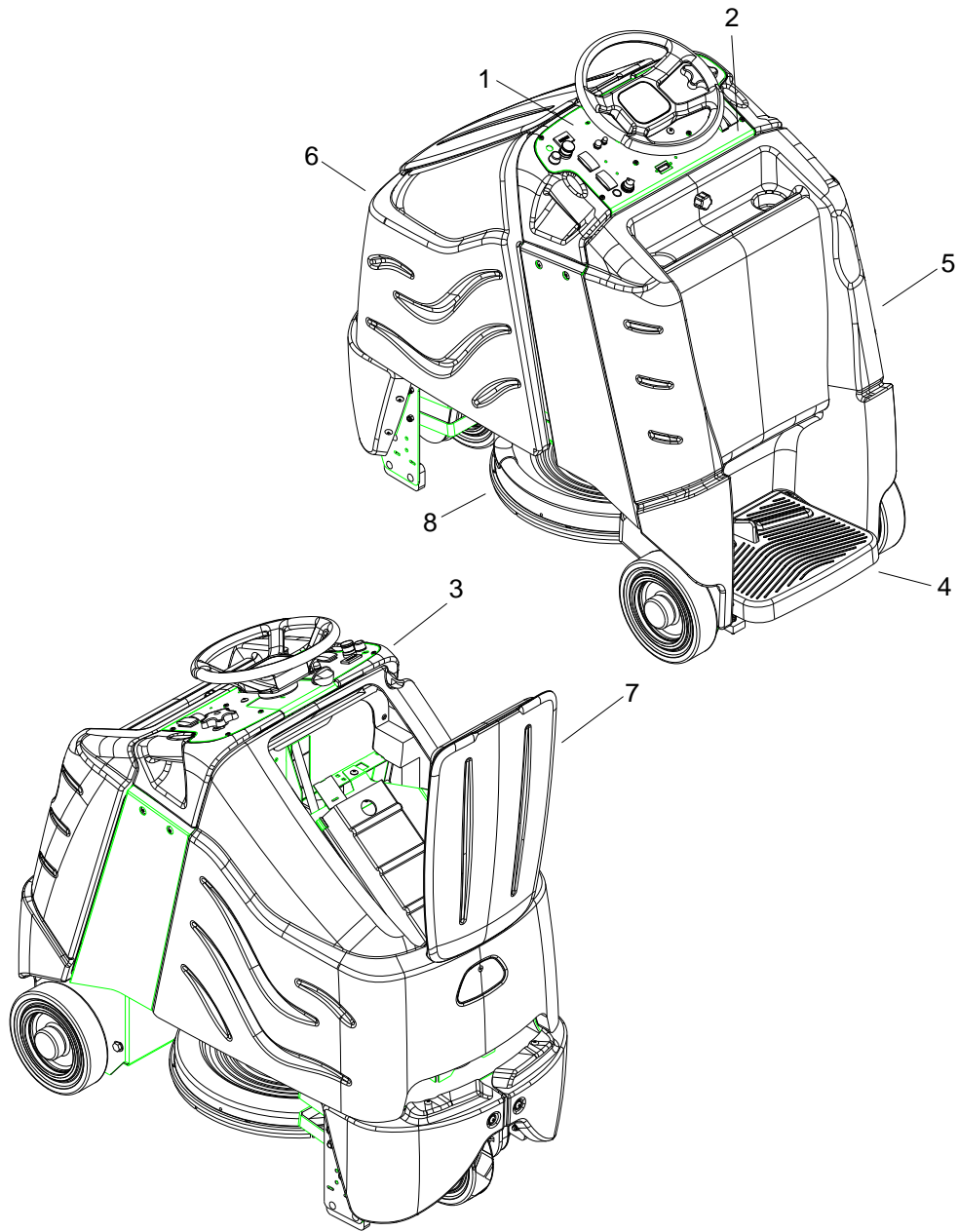

- 1. Control Panel-Drive
- 2. Control Panel-Burnish
- 3. Control Housing
- 4. Pedal Platform

- 5. Rear Cover
- 6. Cover
- 7. Filter Access Lid
- 8. Burnisher Deck

DRIVE CONTROLS

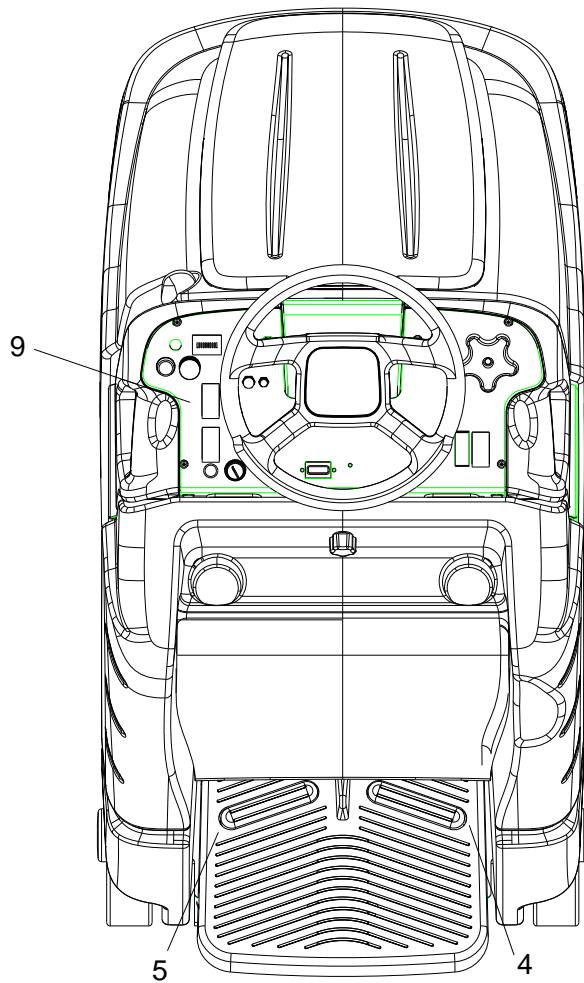
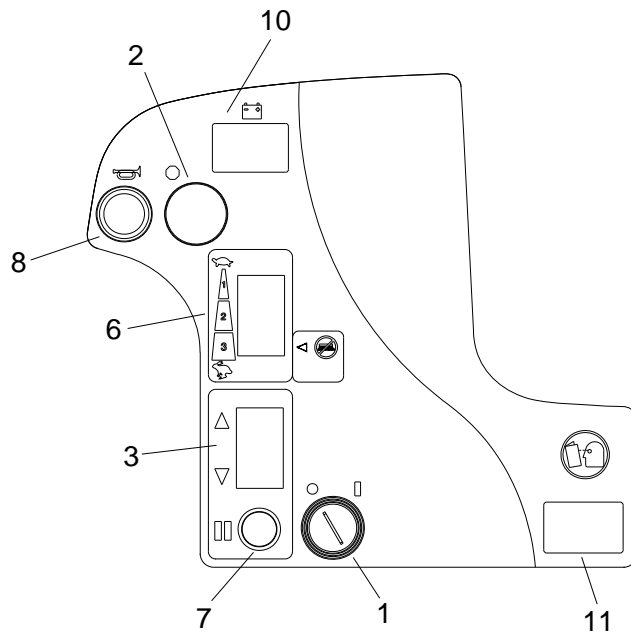

DRIVE CONTROLS

- | | |
|---|--|
| 1. <i>Key Switch</i> | 7. <i>Drive Reset Switch</i> |
| 2. <i>Emergency Stop/Brake Switch</i> | 8. <i>Horn Button</i> |
| 3. <i>Directional Control Switch</i> | 9. <i>Steering Wheel</i> |
| 4. <i>Throttle Pedal</i> | 10. <i>Battery Discharge Indicator</i> |
| 5. <i>Operator Presence Pedal - Prior to Serial Number (4*)</i> | 11. <i>Hour Meter</i> |
| 6. <i>Speed Control Switch</i> | |

1. KEY SWITCH

Controls the power for machine functions.

To turn the machine power on, rotate key clockwise.

To turn the machine off, rotate key counterclockwise.

2. EMERGENCY STOP/BRAKE SWITCH

This safety feature is designed to cut all power to the machine at any time and apply parking brake.

To shut the machine power off, push the Emergency Stop Switch, this will also engage the parking brake and cause the machine to stop immediately.

To reset the machine, rotate the switch clockwise.

3. DIRECTIONAL CONTROL SWITCH

Controls the direction of travel of the vehicle. The position of the switch indicates direction of travel.

To travel forward, press the top of the switch.

To travel in reverse, press the bottom of the switch.

4. THROTTLE PEDAL

Controls the speed of the vehicle within the speed control setting selected. Pressing the pedal causes the machine to travel in the direction selected by the Directional Control Switch.

To increase speed, increase pressure on the pedal.

To decrease speed, decrease pressure on the pedal.

5. OPERATOR PRESENCE PEDAL - Prior to Serial Number (4*)

This safety feature is designed to ensure that the operator has their left foot on pedal platform whenever machine is moving. The operator must have left foot on Operator Presence Pedal for machine to move.

***SEE SERIAL NUMBER PAGE.

DRIVE CONTROLS

6. SPEED CONTROL SWITCH

Controls the maximum speed of the machine. There are two setting intended for scrubbing, speeds 1 and 2. Speed 3 is recommended for transport only, not scrubbing.

To increase speed, press the top of the switch.

To decrease speed, press bottom of the switch. Speeds can be adjusted at any time, whether machine is moving or not.

Basic: The position of the switch indicates speed setting.

Deluxe: The display indicates speed setting. When the key is turned on the controller will automatically adjust the speed to setting 2.

7. DRIVE RESET SWITCH

This safety feature is designed to ensure safe engagement of propel drive. Each time the machine power is turned on, and each time an operator steps on to the platform, the Drive Reset Switch must be pushed before machine will propel.

8. HORN BUTTON

The horn is activated by pressing the horn button.

9. STEERING WHEEL

The steering wheel turns the front wheel causing the machine to change direction.

10. BATTERY CHARGE LEVEL INDICATOR-BASIC

Indicates the charge level of the batteries.

The meter display is divided into 10 vertical bars. Bars illuminated on the far right indicate full charge. Bars flashing near the left side indicate the batteries should be recharged. Further operation of the machine could damage the machine or the batteries.

If the batteries are not fully recharged, the meter will continue to flash on the left side.

11. HOUR METER-BASIC

Records the number of hours the machine has been in operation. This information is useful in determining when to service the machine.

BURNISHER CONTROLS

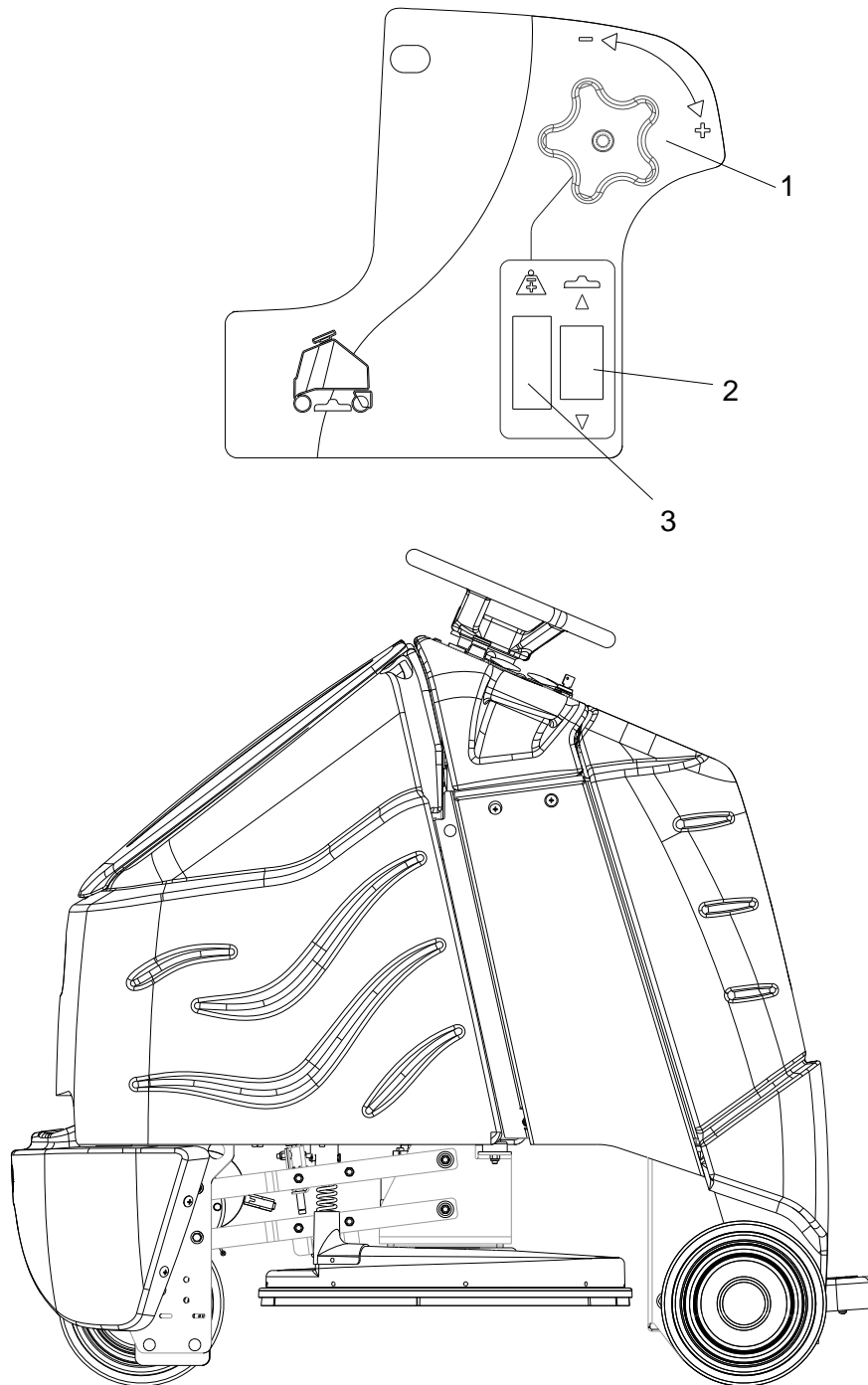

1. *Pad Adjustment Knob*
2. *Burnisher Head Switch*
3. *Pad Pressure Meter*

BURNISHER CONTROLS

1. PAD ADJUSTMENT KNOB

Rotate knob to adjust pad pressure.

2. BURNISHER HEAD SWITCH

Raises/lowers burnisher head.

To lower head, press the bottom of the switch. To raise head, press the top of the switch.

The motor will run only when the head is down and the machine is propelling.

3. PAD PRESSURE METER

Indicates relative pad pressure. "Blue area" indicates proper pad pressure range.

MACHINE OPERATION

PRE-RUN MACHINE INSPECTION

Do a pre-run inspection to find possible problems that could cause poor performance or lost time from breakdown. Follow the same procedure each time to avoid missing steps.

NOTE: See maintenance section for pre-run machine inspection checklist items.

STARTING MACHINE

NOTE: Perform pre-run machine check before operating machine.

FOR SAFETY: Before starting machine, make sure that all safety devices are in place and operating properly.

1. Disconnect the battery charger.
2. Close the cover.
3. Turn or install a new burnishing pad as needed.
4. Stand on the operator platform. Throttle pedal must be in neutral position.

Note: Prior to Serial Number (4*). Place left foot on operator presence pedal. Throttle pedal must be in neutral position.

5. Turn the machine power on by turning key switch clockwise to the "ON" position.
6. Check the position of the Directional Control Switch to make sure the machine will travel in the direction intended.
7. Press the Drive Reset Switch.
8. Press lightly on the throttle pedal with right foot.

*SEE SERIAL NUMBER PAGE.

OPERATING THE MACHINE

1. Lower or raise deck by pressing burnishing head switch.
2. The pad motor will only run when the burnishing head is lowered to within 2 inches of the floor.
3. The pad pressure is adjusted using the knob at right of panel. The operator monitors the amp draw using the meter located on the control panel and ensures that the needle remains in the "blue" operating range.

CAUTION:

To prevent possible damage to the floor surface, always keep the machine moving while the pad is spinning.

4. When the head is down and the machine is propelled, the pad motor runs.
5. Return the machine to the battery charger when the battery light indicator meter indicates discharged batteries

EMERGENCY STOP PROCEDURES

1. Release the throttle pedal by lifting right foot.
2. Turn machine power off with key switch, by turning key switch counterclockwise.
3. If an electrical problem is suspected, push in emergency stop button. This will also engage the parking brake and cause the machine to stop immediately.

MACHINE OPERATION

TO BEGIN BURNISHING

When operating the machine around people, pay close attention for unexpected movement. Use extra caution around children.

1. Stand on the operator platform. Throttle pedal must be in neutral position.

Note: *Prior to Serial Number (4*). Place left foot on operator presence pedal. Throttle pedal must be in neutral position.*

2. Turn machine power on.
3. Check position of Directional Control Switch to ensure that machine is set to travel in direction intended.
4. Press the Drive Reset Switch.

*SEE SERIAL NUMBER PAGE.

NORMAL BURNISHING

Plan the burnishing pattern in advance. The longest track is around the perimeter of the area to be burnished. For efficient operation, the runs should be the longest possible without turning, stopping, or raising or lowering the burnisher head.

In order to achieve the best possible results, the area which is to be burnished should be swept before burnishing.

INEFFICIENT BURNISHING PATH

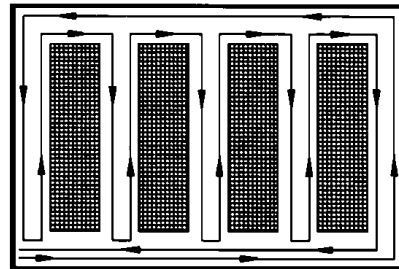

RECOMMENDED BURNISHING PATH

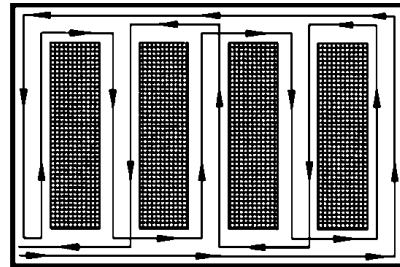

MAINTENANCE

SERVICE SCHEDULE

MAINTENANCE	BEFORE EACH WORK PERIOD	AFTER EACH WORK PERIOD	50 HRS	100 HRS	200 HRS
Check water level of batteries after charging; add distilled water if necessary.	*				
Visually check for damaged or worn tires.	*				
Check pad for proper installation.	*				
Check dust vacuum hose connections.	*				
Check pedal(s), brake and steering for proper operation.	*				
Check dust bag.		*			
Charge batteries.		*			
Clean off top of batteries.			*		
Check battery cells with hydrometer.			*		
Check battery connections are tight.			*		
Clean battery cases and battery compartment.				*	
Clean and check drive tension chain for wear and tension.				*	
Check parking brake.					*
Clean pivot points on burnishing head.					*
Check drive motor for carbon brush wear.					*
Check steering chain tension.					*

NOTE: The pad drive motor contains no carbon brushes and requires no service.

MAINTENANCE-BATTERIES

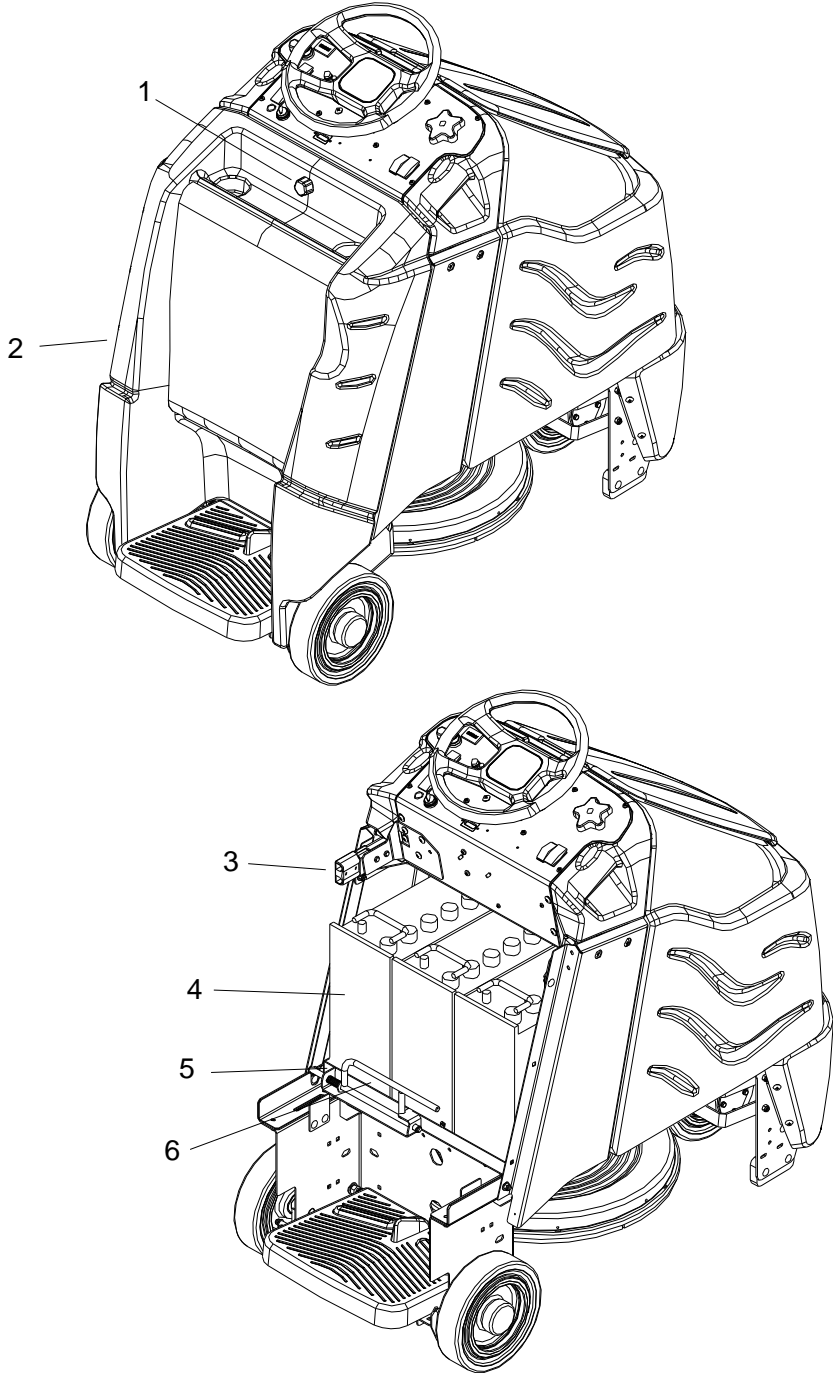

-
- 1. *Rear Cover Retainer Knob*
 - 2. *Rear Cover*
 - 3. *Battery Connector-Machine*
 - 4. *Batteries*
 - 5. *Battery Tray*
 - 6. *Battery Tray Latch*

MAINTENANCE-BATTERIES

BATTERIES

The batteries provide the power to operate the machine. The batteries require regular maintenance to keep them operating at peak efficiency.

The machine batteries will hold their charge for long periods of time, but they can only be charged a certain number of times. To get the greatest life from the batteries, charge them when their charge level reaches 25% of a full charge. Use a hydrometer to check the charge level.

Do not allow the batteries to remain in a discharged condition for any length of time. Never expose a discharged battery to temperatures below freezing. Discharged batteries will freeze causing cracked cases. Do not operate the machine if the batteries are in poor condition or if they have a charge level below 25% (specific gravity below 1.155).

Keep all metallic objects off the top of the batteries, as they may cause a short circuit. Replace worn or damaged cables and terminals.

Check the electrolyte level in each battery cell before and after charging the batteries. Never add acid to the batteries, use distilled water. Do not allow water level to fall below the battery plates. Portions of plates exposed to air will be destroyed. Do not overfill. Keep plugs firmly in place at all times.

 **CAUTION:** When servicing machine, avoid contact with battery acid.

 **WARNING:** Batteries emit hydrogen gas. Explosion or fire can result. Keep sparks and open flame away. Keep covers open when charging.

 **WARNING:** Wear eye protection and protective clothing when working with batteries.

 **WARNING:** Charge batteries in a well ventilated area.

BATTERY MAINTENANCE

1. When cleaning the batteries, use a solution of baking soda and water. Do not allow the cleaning fluid to enter the battery cells, electrolyte will be neutralized.
2. Maintain the proper electrolyte level in each battery cell. If a cell should accidentally overflow, clean immediately.
3. Wipe off the top of the batteries at least once a week.
4. Test battery condition with a hydrometer at least once a week.
5. Ensure that all connections are tight and all corrosion removed.
6. Every 4 to 6 months, remove that batteries from the machine and clean the battery cases and battery compartment.

MAINTENANCE-BATTERIES

CHECKING BATTERY SPECIFIC GRAVITY

Use a hydrometer to check the battery specific gravity.

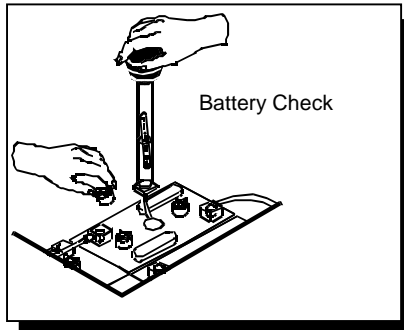

CHECKING GRAVITY

- A. Hydrometer
- B. Battery

NOTE: Do not take readings immediately after adding distilled water, if the water and acid are not thoroughly mixed, the reading may not be accurate.

Check the hydrometer readings against this chart.

SPECIFIC GRAVITY @ 80° F (27°C)	BATTERY CONDITION
1.265	100% CHARGED
1.225	75% CHARGED
1.190	50% CHARGED
1.155	25% CHARGED
1.120	DISCHARGED

NOTE: If the readings are taken when the battery electrolyte is any temperature other than 80° F (27°C), the reading must be temperature corrected.

To find the corrected specific gravity reading when the temperature of the battery electrolyte is other than 80° F (27°): Add (+) to the specific gravity reading 0.004 (4 points), for each 10° F (6° C) above 80° (27° C).

Subtract (-) from the specific reading 0.004 (4 points), for each 10° F (6° C) below 80° F (27° C).

CHARGING BATTERIES

CAUTION: When servicing machine, avoid contact with battery acid.

WARNING: Batteries emit hydrogen gas. Explosion or fire can result. Keep sparks and open flame away. Keep covers open when charging.

WARNING: Wear eye protection and protective clothing when working with batteries.

WARNING: Charge batteries in a well ventilated area.

Use a 36 volt, 20 amp maximum output DC charger which will automatically shut off when the batteries are fully charged.

1. Stop the machine in a clean, well ventilated area next to the charger.
2. Turn "OFF" machine.

FOR SAFETY: Before leaving or servicing machine; stop on level surface, turn off machine and remove key.

3. Remove rear cover, unplug batteries from machine, unlatch battery tray and pull out to expose batteries.

WARNING: Batteries emit hydrogen gas. Explosion or fire can result. Keep sparks and open flame away. Keep covers open when charging.

4. Check the electrolyte level in each battery cell. Before charging, add just enough distilled water to cover the plates. After charging is complete, add just enough distilled water to bring up the level to the indicator ring. If the water level is too high before charging, normal expansion rate of the electrolyte may cause an overflow resulting in a loss of battery acid balance and damage the machine.

MAINTENANCE-BATTERIES

5. Replace the battery caps, and leave them in place while charging.
6. Unplug the battery connector from the machine.

FOR SAFETY: When charging, connect the charger to the batteries before connecting the charger to the AC wall outlet. Never connect the charger to the AC wall outlet first. Hazardous sparks may result.

7. Plug the charger connector into the battery connector. Connect the charger AC plug to a wall outlet. The charger gauge should indicate that the batteries are charging.
8. When the batteries are fully charged, disconnect the charger from the AC wall outlet, then disconnect the charger from the batteries.
9. Connect the batteries to the machine connector.
10. Check the electrolyte level. It should be up to the indicator ring. If necessary, add distilled water.
11. Install the rear cover.

CHANGING BATTERIES

Stop the machine in a clean area next to the charger. Turn off machine.

FOR SAFETY: Before leaving or servicing the machine; stop on level surface, turn off machine and remove key.

1. Remove the rear cover.
2. Disconnect battery pack from machine.
3. Unlatch battery tray from machine and pull out to expose batteries.
4. Use the proper size open end wrench to disconnect main ground wire first and secure cable terminal away from batteries.
5. Disconnect main positive lead and secure cable terminals away from batteries.
6. Loosen both terminals on each jumper cable and remove one at a time.
7. Prepare a suitable site to place the batteries.
8. Attach suitable battery lifting device and lift batteries from the machine.

⚠ WARNING: Batteries are a potential environmental hazard. Consult your battery supplier for safe disposal methods.

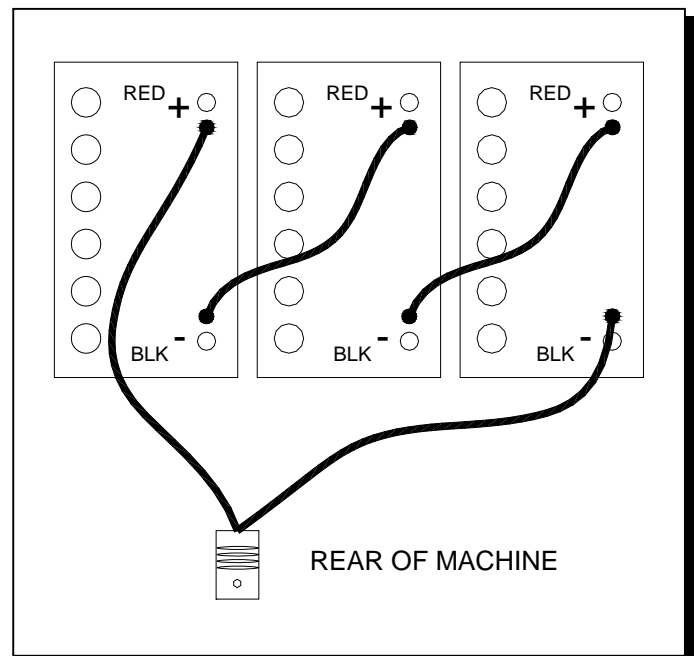

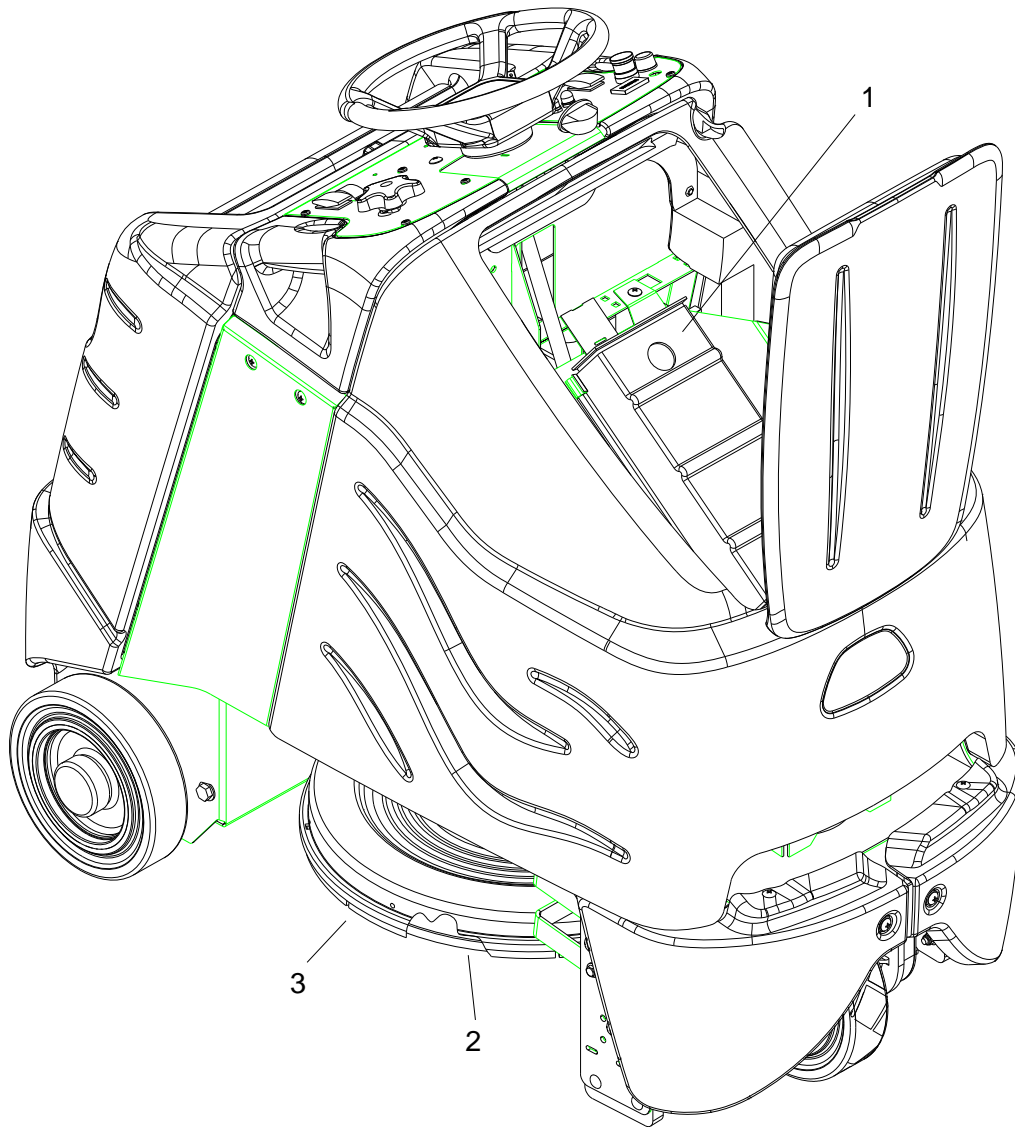

-
1. *Dust Bag/Filter*
 2. *Pads*
 3. *Skirts*

MAINTENANCE

DUST BAG REPLACEMENT

1. Raise cover to expose filter cover.
2. Using lifting access hole, lift bag cover.
3. Carefully remove bag from hose.
4. Slide a new bag onto hose. Ensure bag is pushed on so that top of bag rest on top lip of filter cover.

DUST CONTROL SKIRTS

Replace skirts when worn, torn, or damaged in any way that allows dust to escape.

1. Remove skirt strips by pulling down.
2. Insert new skirt strips and snap them into place.

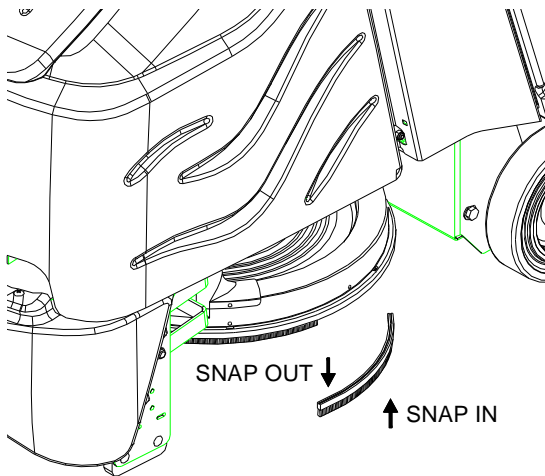

PAD INSTALLATION

Install pad using the pad centering tool (86064370 – PRV NO. 66829).

1. Lay the pad in the pan and position under the pad driver. The edges of the pan will align the pad and driver.
2. Screw the center lock in place through the hole in the pan. The center lock has a right hand thread.

The pad centering tool can be stored under the hood.

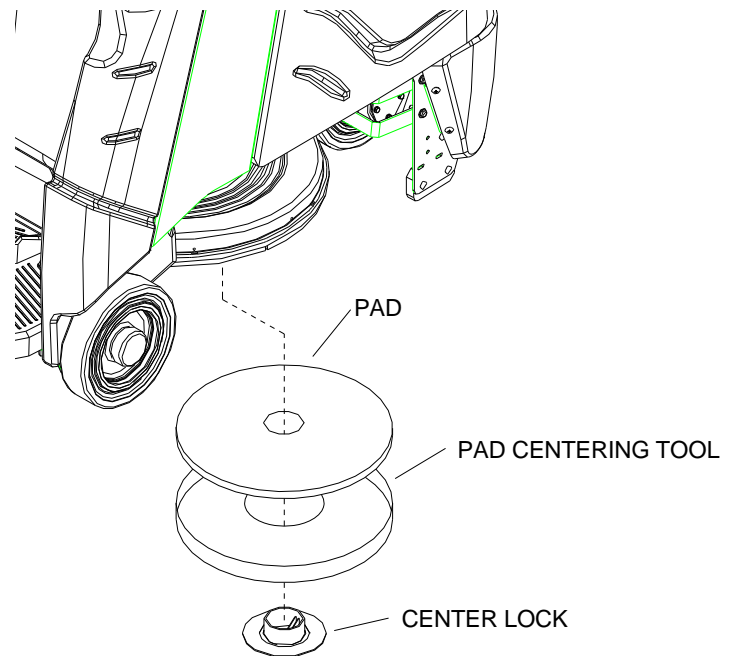

MAINTENANCE-PAD DRIVER

PAD DRIVER REPLACEMENT

Turn key switch on to lower deck down. Make sure pad adjustment knob is turned fully in the up position (-) counter clockwise. Use needle nose vise grips to clamp together spring retainer bars between spring.

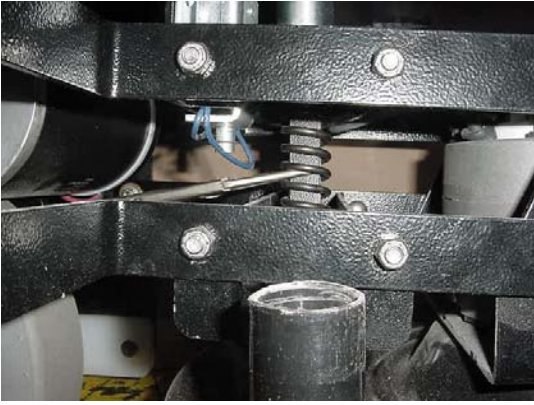

Remove the four bolts holding deck assembly onto frame. Two bolts on each side.

Label and remove wires coming off of motor. Disconnect by unplugging motor wire harness from machine wire harness. Take note cable tie locations.



Slide deck out from under machine and turn deck assembly over on to motor. Remove pad lock and pad.



Attach metal ring (86082070 – PRV NO. 629000) using same screws that held pad lock keeper. Screw in spacer (862454470 – PRV NO. 739000) into motor shaft.

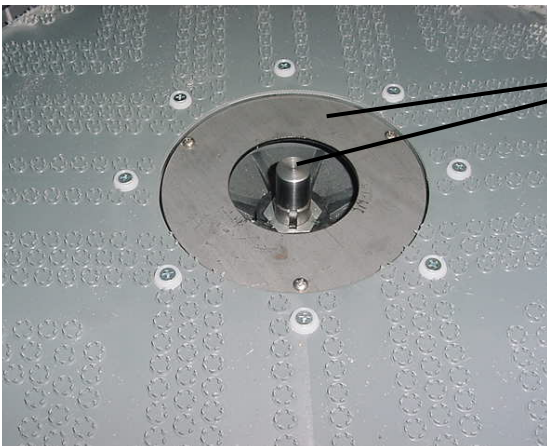

MAINTENANCE-PAD DRIVER

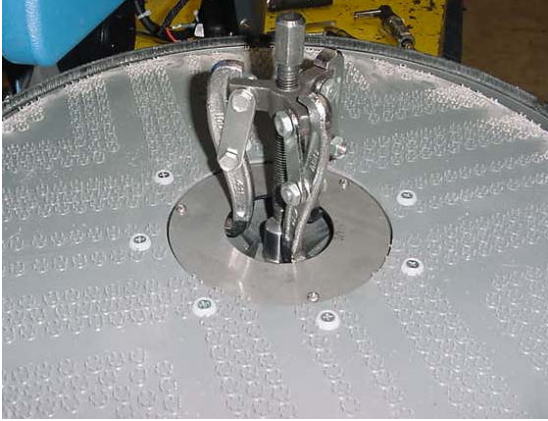

Use Gear puller to remove pad driver from motor shaft. Take care not to misplace motor shaft key.



Install new pad driver, motor shaft key, spacer, washer and bolt. Then install pad lock keeper, pad and pad lock. Turn deck assembly over onto pad

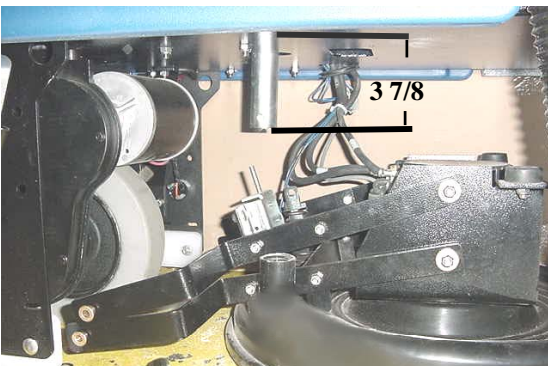

Reattach wires to motor and connect motor wire harness to frame harness. Tie wires in place. Set actuator barrel by rotating barrel up or down to set barrel at $3 - 7/8 +0 - 3/16$ from top of frame to bottom of barrel.



Reattach deck assembly to frame. Install actuator barrel on to spring retainer bars. Lift bottom of deck using your hand to align hole for clevis pin. Install clevis and rue ring. Turn machine on, raise deck, drive machine check that machine is working properly. If not recheck actuator barrel and reset again if needed.

SHUNT ADJUSTMENT

This pad pressure meter adjustment is factory set. Over the course of time it may become necessary to adjust this setting using the slotted connection on the shunt.

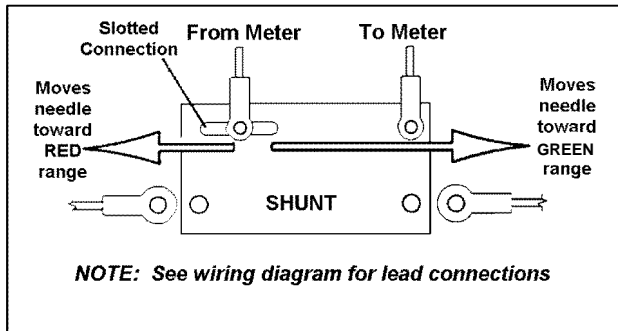

Check the amp range when nuisance tripping of the pad motor controller indicates that the shunt may be out of adjustment.

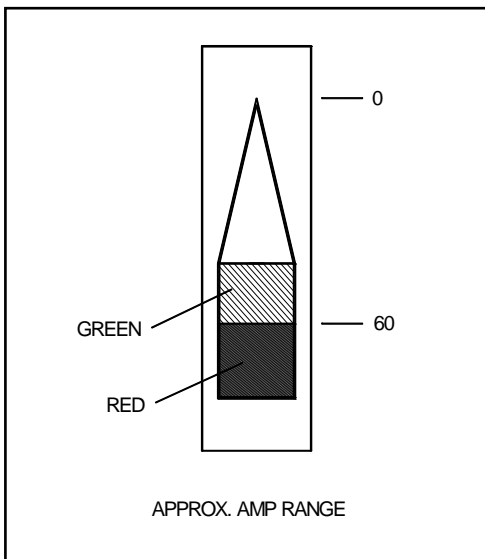

1. Connect a DC ampere meter to the positive battery lead. Running the machine with a pad, lower the pad to the floor until it is operating at 60 ± 5 amps.
2. Moving the wire in the slot, adjust the pad pressure meter until the needle sets at the line between the blue and red areas.

MAINTENANCE-DRIVE MOTOR & BRAKE

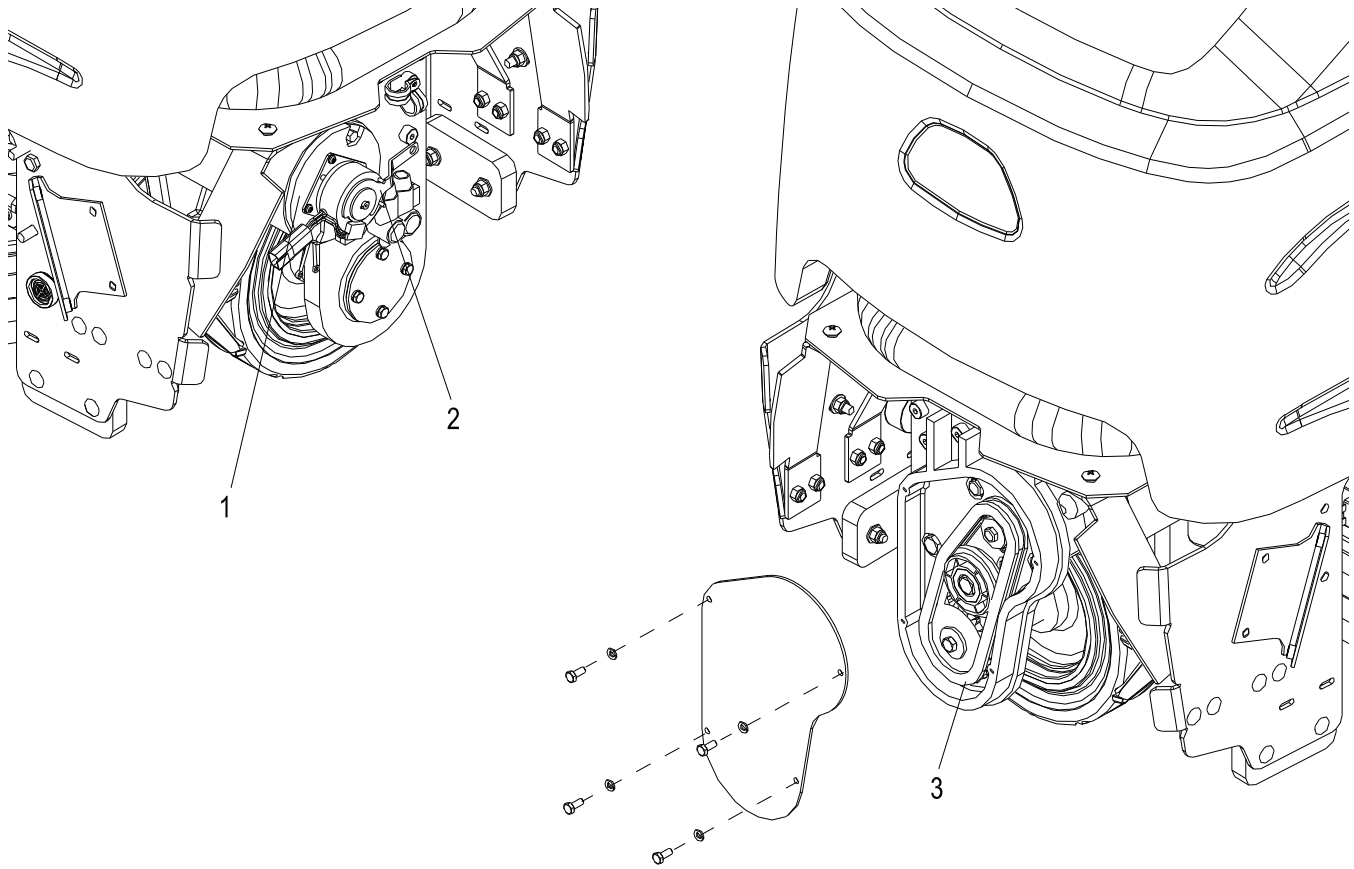

-
1. *Drive motor*
 2. *Parking brake*
 3. *Drive chain*

MAINTENANCE-DRIVE MOTOR & BRAKE

ELECTRIC PARKING BRAKE ENGAGEMENT

FOR SAFETY: Before leaving or servicing machine, stop on a level surface, turn off machine and remove key.

Electric Brake Engagement

This machine is equipped with an electric parking brake.

The brake automatically engages and keeps the machine from moving whenever the operator steps off the platform or when emergency stop is engaged.

The brake has a mechanical over-ride that can be engaged so machine can be pushed or towed (slowly).

When the mechanical over-ride is engaged the machine cannot be driven.

To engage brake:

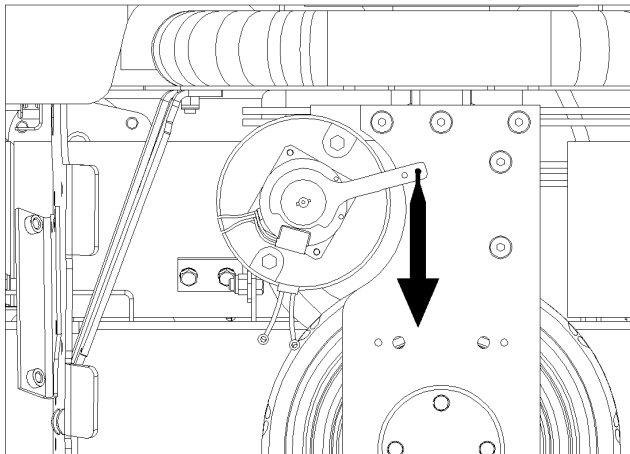

1. Mechanical over-ride engaged.
Machine can be pushed or towed (slowly).
2. Push lever firmly in direction of arrow

Note: There is an intermediate stop. Make sure lever is fully in the down position.

To disengage brake:

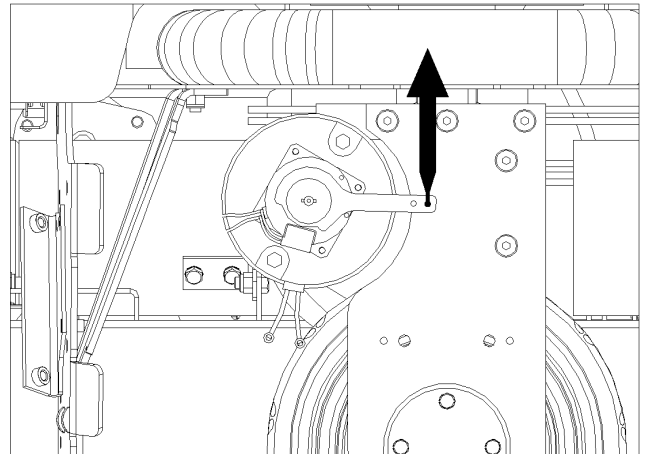

1. Mechanical over-ride disengaged
Machine can be driven.
2. Push lever firmly in direction of arrow.

MAINTENANCE-DRIVE MOTOR & BRAKE

DRIVE MOTOR CARBON BRUSH REPLACEMENT

⚠ WARNING: Do not use a pressure washer to clean around the motors. Use tap pressure only.

FOR SAFETY: Before leaving or servicing machine, stop on a level surface, turn off machine and remove key.

1. Disconnect batteries from machine.
2. Disconnect the electrical connection to the traction motor.

BRAKE REMOVAL

(Must be done to access carbon brushes)

3. Remove 4 mounting screws and remove brake.
4. Drive roll pin out of the hex hub enough to allow hex hub to slide off shaft. Its is recommended that the roll pin be left partially in the hex hub.

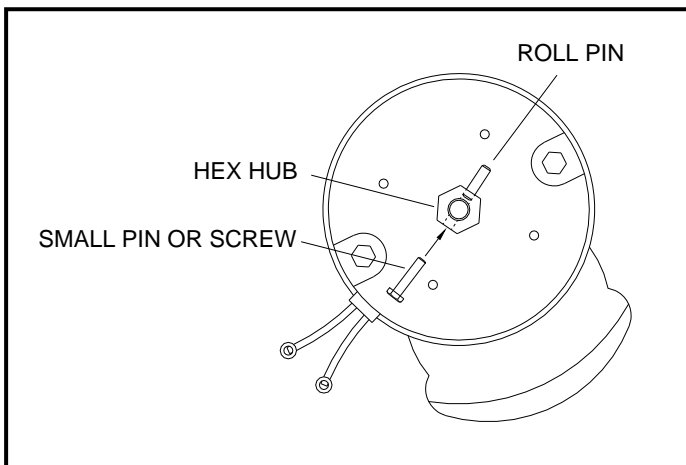

7. Install new brush and reinstall connecting screw and lead.
8. When all new brushes are installed. Place all in retracted position, held into brush holder by spring tension.
9. Carefully replace brush cap.

Reinstalling:

10. When replacing the hex hub, use a small pin or screw to help align the holes.
11. Drive the pin into the hub and make sure it is flush to the hex surface. The brake will not fit on the hub if the roll pin is protruding from the hub.
12. Replace the hub and use Lock-Tite on the screws.

5. Remove brush cap.
6. Release brush from spring tension. Remove screw connecting brush wire lead to brush holder. Clean brush holder to insure free movement.

MAINTENANCE-CIRCUIT PROTECTION

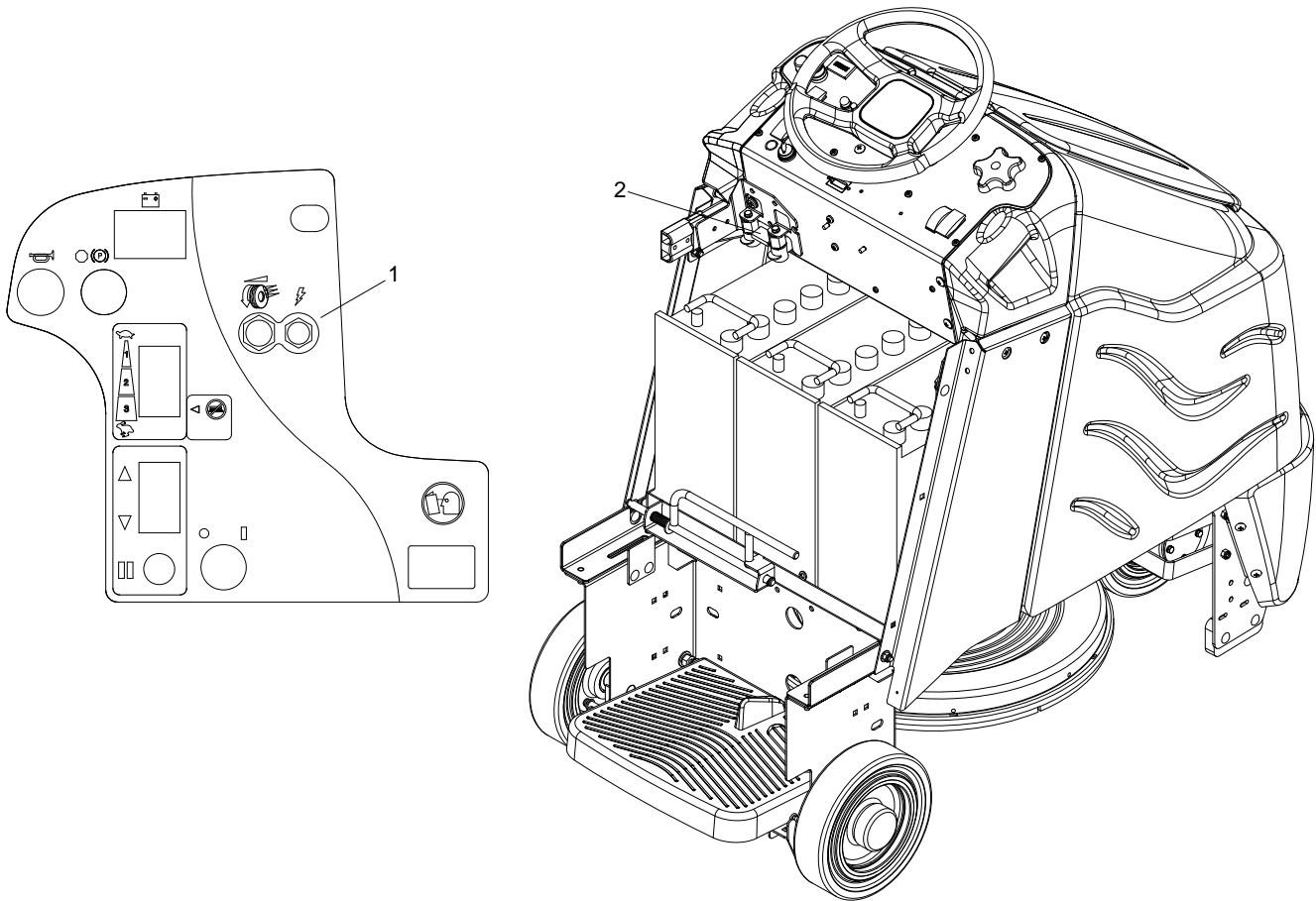

1. CIRCUIT BREAKERS

Circuit breakers interrupt the flow of power in the event of an electrical overload. When a circuit breaker is tripped, reset it by pressing the exposed button. If a circuit breaker continues to trip, the cause of the electrical overload should be found and corrected.



30 Amp. Protects the propel motor.



3 Amp. Protects the machine controls. (Basic only).

2. FUSE

The fuse is a one-time circuit protection device designed to stop the flow of electrical current in the event of an electrical overload. The fuse protects the burnisher pad motor and controller. If fuse is blown, it must be replaced.

The fuse is located inside the battery compartment.

TROUBLESHOOTING

PROBLEM	CAUSE	SOLUTION
No power to machine	Battery disconnected	Check all battery cable connections
	Emergency shut-off activated	Reset
	Battery cables corroded	Clean connections
	Faulty key switch	Replace switch
Little or no propel	Low battery charge	Charge batteries
	Machine turned on with pedal not in neutral position	Allow pedal to return to neutral. Restart
	Tripped circuit breaker	Reset circuit breaker
	Controller overheated	Allow cool down period
	Loose motor connection	Check wires and connections from controller to motor
	Faulty throttle circuit or potentiometer	Check wires and connections from throttle to controller and potentiometer resistance
	Faulty drive reset circuit or switch	Check wires, connections and switch
	Faulty operator presence pedal circuit or switch - Prior to Serial Number (4*).	Check wires, connections and switch
	Faulty platform circuit or switch	Check wires, connections and switch
	Brake over-ride engaged	Disengage brake over-ride
	Faulty brake circuit or over-ride switch	Check wires, connections and switch
Machine does not change speeds	Faulty speed control circuit or switch	Check wires, connections and switch
Forward speed only Reverse speed only	Faulty forward/reverse switch	Replace switch
Deck won't go up or down	Circuit breaker tripped	Reset circuit breaker
Pad motor won't run	Fuse blown	Replace fuse
	Faulty switch or connection	Check switch or connections
	Faulty relay	Check pad motor relay
Deck vibrates	Pad off center	Re-center or replace pad using pad install tool
Dust leaks from skirts	Dust hose blocked	Check for blockage and clear if needed

*SEE SERIAL NUMBER PAGE.

MACHINE TROUBLESHOOTING- CONTROLLER FAULT CODES

PROPEL CIRCUIT BOARD TROUBLESHOOTING

Curtis 1228 LED DIAGNOSTICS- Basic and Cylindrical

During normal operation, with no faults present, the status LED is steadily on. If the controller detects a fault, the status LED provides two types of information. First, it displays a slow flash (2 Hz) or a fast flash (4 Hz) to indicate the severity of the fault. Slow-flash faults are self-clearing; as soon as the fault is corrected, the vehicle will operate normally. Fast-flash faults (“.” in Table 2) are considered to be more serious in nature and require that the key switch be cycled to resume operation after the fault is corrected.

After the severity indication has been active for 10 seconds, the status LED flashes a 2-digit fault identification code continuously until the fault is corrected. For example, code “1,4”—low battery voltage—appears as: one LED flash, followed by a pause, then 4 LED flashes, and then repeats.

LED CODE	PROGRAMMER LCD DISPLAY	EXPLANATION	POSSIBLE CAUSE
1,1	THERMAL CUTBACK	over-/under-temperature cutback	<ol style="list-style-type: none"> 1. Temperature >92°C or < -25°C. 2. Excessive load on vehicle. 3. Operation in extreme environments. 4. Electromagnetic brake not releasing.
1,2	THROTTLE FAULT 1	throttle fault	<ol style="list-style-type: none"> 1. Throttle input wire open or shorted. 2. Throttle pot defective. 3. Wrong throttle type selected.
1,3	SPD LIMIT POT FAULT	speed limit pot fault	<ol style="list-style-type: none"> 1. Speed limit pot wire(s) broken or shorted. 2. Broken speed limit pot.
1,4	LOW BATTERY VOLTAGE	battery voltage too low	<ol style="list-style-type: none"> 1. Battery voltage <17 volts. 2. Bad connection at battery or controller.
1,5	OVERVOLTAGE	battery voltage too high	<ol style="list-style-type: none"> 1. Battery voltage >36 volts. 2. Vehicle operating with charger attached. 3. Intermittent battery connection.
2,1	MAIN OFF FAULT	main contactor driver Off fault	<ol style="list-style-type: none"> 1. Main contactor driver failed open.
2,3	MAIN CONT FLTS	main contactor fault	<ol style="list-style-type: none"> 1. Main contactor welded or stuck open. 2. Main contactor driver fault. 3. Brake coil resistance too high.
2,4	MAIN ON FAULT	main contactor driver On fault	<ol style="list-style-type: none"> 1. Main contactor driver failed closed.

MACHINE TROUBLESHOOTING- CONTROLLER FAULT CODES

LED CODE	PROGRAMMER LCD DISPLAY	EXPLANATION	POSSIBLE CAUSE
3,1	PROC/WIRING FAULT	HPD fault present for >10 sec.	1. Misadjusted throttle. 2. Broken throttle pot or throttle mechanism.
3,2	BRAKE ON FAULT	brake On fault	1. Electromagnetic brake driver shorted. 2. Electromagnetic brake coil open.
3,3	PRECHARGE FAULT	precharge fault	1. Low battery voltage. 2. KSI and throttle turned on at same time.
3,4	BRAKE OFF FAULT	brake Off fault	1. Electromagnetic brake driver open. 2. Electromagnetic brake coil shorted.
3,5	HPD	HPD (High Pedal Disable) fault	1. Improper sequence of throttle and KSI, push, or inhibit inputs. 2. Misadjusted throttle pot.
4,1	CURRENT SENSE FAULT	current sense fault	1. Short in motor or in motor wiring. 2. Controller failure. *
4,2	HW FAILSAFE	motor voltage fault (hardware)	1. Motor voltage does not correspond to throttle request. 2. Short in motor or in motor wiring. 3. Controller failure. *
4,3	EEPROM FAULT	EEPROM fault	1. EEPROM failure or fault.
4,4	POWER SECTION FAULT	power section fault	1. EEPROM failure or fault. 2. Short in motor or in motor wiring. 3. Controller failure.



***BURNISHER
PARTS***

BUMPER

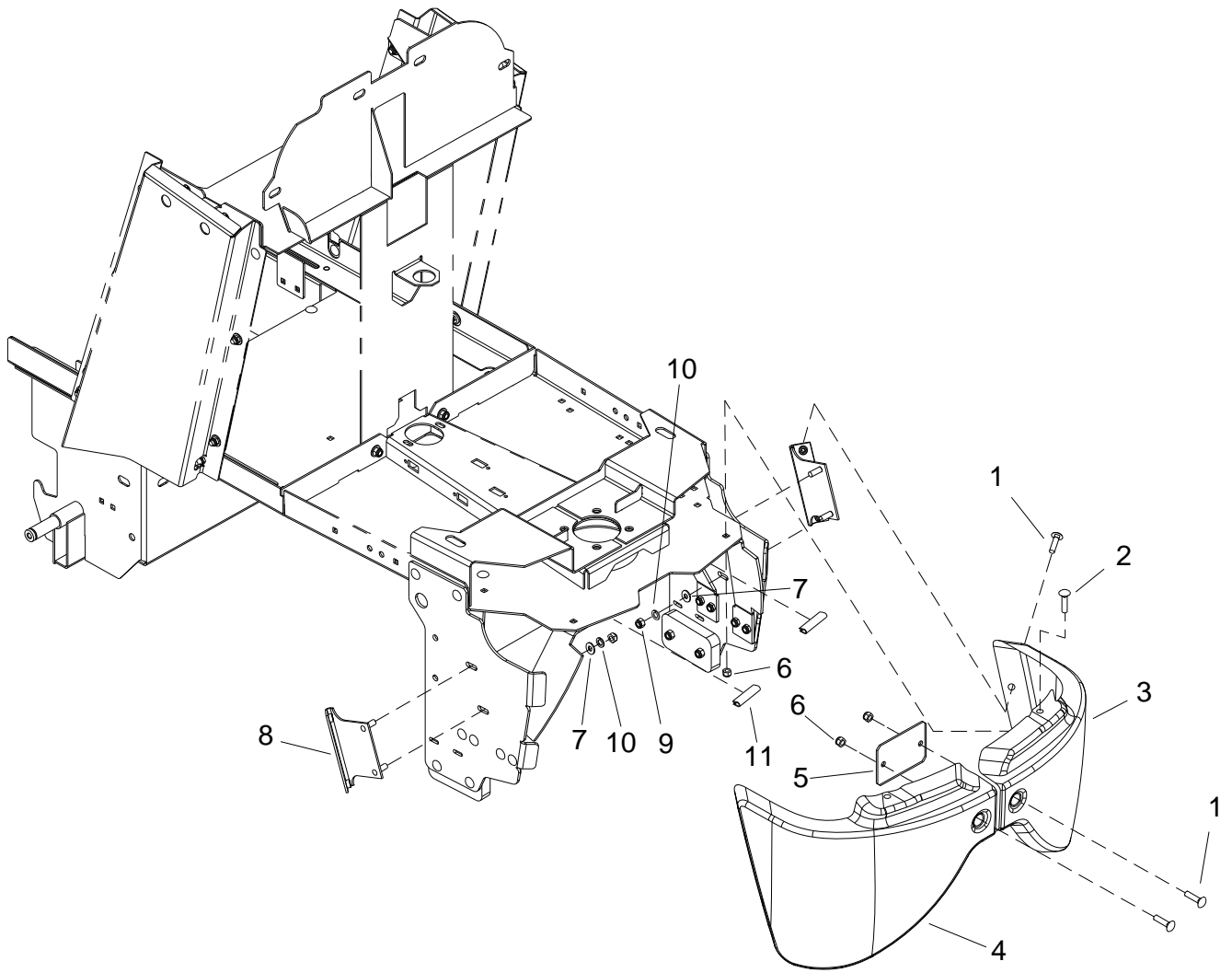

BUMPER

REF	PART NO.	PRV NO.	QTY	DESCRIPTION	SERIAL NO. FROM	NOTES:
1	86276890	70752	6	SCR, 5/16-18X3/4 PTHMS SS		
2	86007070	70849	2	SCR, #12 X 1.25 PPHMS SS		
3	86063230	140813	1	BUMPER, LEFT		
4	86063240	140814	1	BUMPER, RIGHT		
5	86071020	140783	1	BRKT, FRONT BUMPER		
6	86270830	57023	4	NUT, 5/16-18 HEX NYLOCK SS		
7	86010670	87029	4	WASHER, 5/16 FLAT SS		
8	86070730	140729	2	BRKT, BUMPER MOUNT, SIDE		
9	86197040	57264	4	NUT, 5/16-18 HEX ACORN PLTD		
10	86279130	87083	4	WASHER, 5/16 SPLIT LOCK		
11	86251750	67602	2	RISER, BUMPER		

CONTROL PANEL

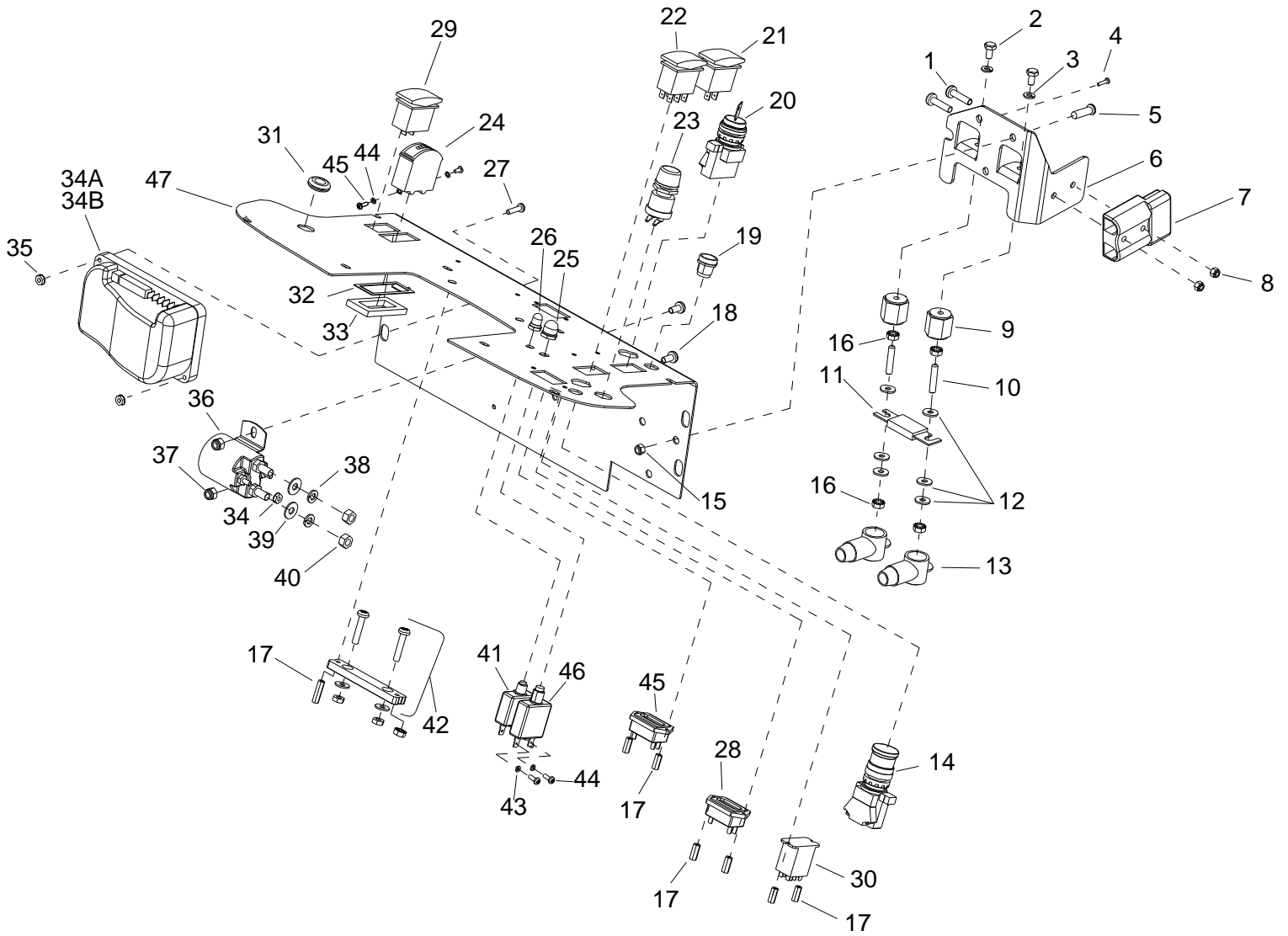

CONTROL PANEL

REF	PART NO.	PRV NO.	QTY	DESCRIPTION	SERIAL NO. FROM	NOTES:
1	86273820	70019	2	SCR, 1/4-20 X 1.25 HHCS		
2	86273830	70020	2	SCR, 1/4-20 X 1/2 HHCS SS		
3	86010780	87162	2	WASHER, 1/4 SPLIT LOCK		
4	86274380	70192	2	SCR, M5 X 15 PPHMS PLTD		
5	86277480	70850	3	SCR, 5/16-18 X 1/2 PTHMS SS		
6	86070670	140722	1	BRKT, BATTERY CONNECTOR		
7	86008760	80682	1	CONN, 175 DCA GRY W/O TERMS		
8	86005810	57245	2	NUT, 1/4-20 HEX NYLOCK SS		
9	86255910	73659	2	STANDOFF, 1/4-20 X 1.0 HEX INS		
10	86006850	70393	2	SET SCR, 1/4-20 X 1.25L		
11	86237000	80688	1	FUSE, 80 AMP		
12	86010630	87013	6	WASHER, 1/4 ID X 5/8 OD SS		
13	86008920	80889	2	BOOT, RUBBER TERM. ISOLATOR		
14	86007180	72160	1	SWITCH, EMERGENCY STOP		
15	86270830	57023	3	NUT, 5/16-18 HEX NYLOCK SS		
16	86005710	57105	4	NUT, 1/4-20 HEX W/STAR WASHER		
17	86255900	73538	8	STANOFF, 6-32 X 5/8 HEX NYL		
18	86223740	70872	2	SCR, 1/4-20 X .59 PPHMS SS C		
19	86257140	72196	1	SWITCH ASM, SEALED PB RND GRN		
20	86007190	72161	1	SWITCH KEY DPST		
21	86007140	72130	1	SWITCH, SPST 2-POSITION ROCKER		
22	86257110	72189	1	SWITCH, 4P3T FIXED POS ROCKER		
23	86257280	81371	1	SWITCH, PUSH BUTTON		
24	86246920	54131	1	METER, 0-70 AMP L2020B		
25	86008900	80845	1	BOOT, SEAL-PUSH BUTTON 7/16-28		
26	86002010	14942	1	BOOT, 3/8 CIRCUIT BREAKER		
27	86273980	70066	2	SCR, 10-32 X 3/4 PPHMS		
28	86246930	54144	1	METER, 36V BATTERY CHARGE LEVEL		
29	86007130	72128	1	SWITCH, DPDT 2-POSITION ROCKER		
30	86251410	67506	1	RELAY, 15A 36V MINI		
31	86226560	36082	1	GROMMET, 1/2 ID X 3/32 GROOVE		
32	86249290	62283	1	PLATE, METER RETAINING		
33	86237830	35264	1	GASKET, AMP METER		
34A	86002760	270092	1	CONTROLLER, CHAIN DRIVE BASIC	FOR 29269	DRIVE UNIT (CHAIN)
34B	86027740	27911	1	CONTROLLER, GEAR DRIVE BASIC	FOR 29276	DRIVE UNIT (GEAR)
35	86005700	57104	3	NUT, 10-32 W/STAR WASHER PLTD		
36	86006370	67315	1	RELAY, 36VDC 100AMP HVY DUTY		
37	86005810	57245	2	NUT, 1/4-20 HEX NYLOCK SS		
38	86279130	87083	2	WASHER, 5/16 SPLIT LOCK PLTD		
39	86010670	87029	2	WASHER, 5/16 FLAT SS		
40	86271120	57125	2	NUT, 5/16-18 BRASS		
41	86002000	14717	1	BREAKER, 3 AMP		
42	86229770	140805	1	BLOCK, SHUNT MOUNT		
43	86279300	87134	4	WASHER, #6 LOCK		
44	86273990	70067	4	SCR, 6-32 X 3/8 PPHMS		
45	86005530	54154	1	METER, 12-48 VDC LED HOUR		
46	86001910	14606	1	BREAKER, 30A 50VDC CIRCUIT		
47	86078170	61479	1	PANEL, BURNISHER		

CONTROLS & HOUSING

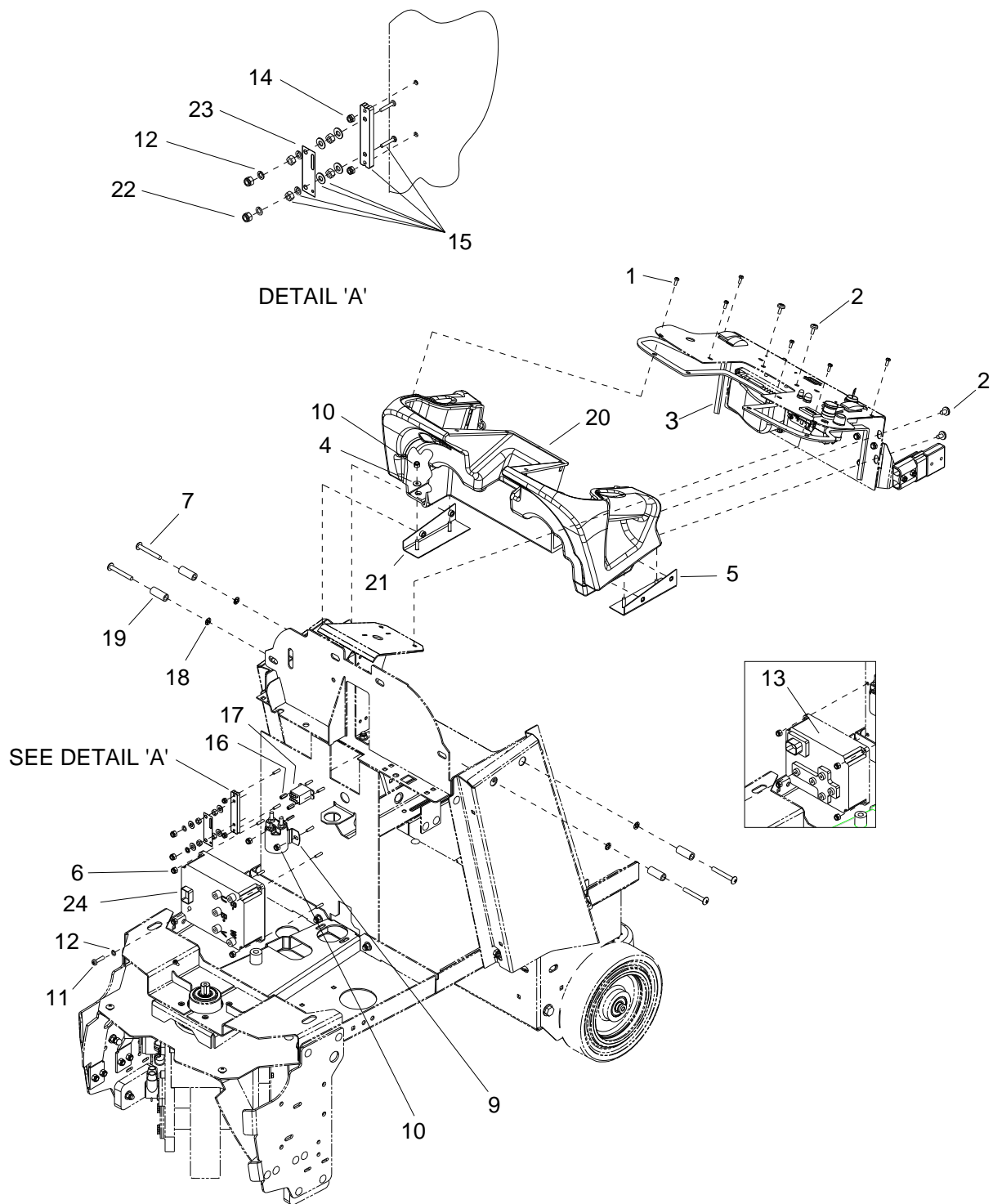

CONTROLS & HOUSING

REF	PART NO.	PRV NO.	QTY	DESCRIPTION	SERIAL NO. FROM	NOTES:
1	86290540	-	6	SCR, 10-32 X 1/2 TORX SS BLK NP		
2	86277480	70850	2	SCR, 5/16-18 X 1/2 PTHMS SS		
3	86237900	35278	3	GASKET, .125 T X .25 W X 23.L		
4	86010670	87029	4	WASHER, 5/16 FLAT SS		
5	86070710	140726	1	BRKT, LEFT CONSOLE MOUNT		
6	86270850	57026	2	NUT, 8-32 HEX NYLOCK SS		
7	86277420	70841	4	SCR, 5/16-18 X 2.5 PTHMS SS		
8	86062220	270117	1	CONSOLE		
9	86006370	67315	1	RELAY, 36VDC 100AMP HVY DUTY		
10	86005810	57245	6	NUT, 1/4-20 HEX NYLOCK SS		
11	86273300	00-000277	5	SCR, MACH 6MM X 14MM		
12	86010780	87162	5	WASHER, 1/4 SPLIT LOCK PLTD		
13	86331360	-	1	KIT, BURNISHER CONTROLLER		
14	86270990	57090	4	NUT, 10-32 HEX NYLOCK SS		
15	86229770	140805	1	BLOCK, SHUNT MOUNT		
16	86255900	73538	2	STANDOFF, 6-32 X 5/8 HEX NYL		
17	86251410	67506	1	RELAY, 15A 36V MINI		
18	86279750	87252	4	WASHER, RET, PUSHNUT, 5/16 BOLT		
19	86089650	78524	4	TUBE, 5/8 OD X .357 ID X 1.57		
20	86273980	70066	2	SCR, 10-32 X 3/4 PPHMS		
21	86070700	140725	1	BRKT, RIGHT CONSOLE MOUNT		
22	86005710	57105	2	NUT, 1/4-20 HEX W/STAR WASHER		
23	86253600	73445	1	SHUNT, 50MV 70AMP		
24	86233990	240145	1	CONTROLLER, PAD MOTOR	**	WAS 270106

DECALS

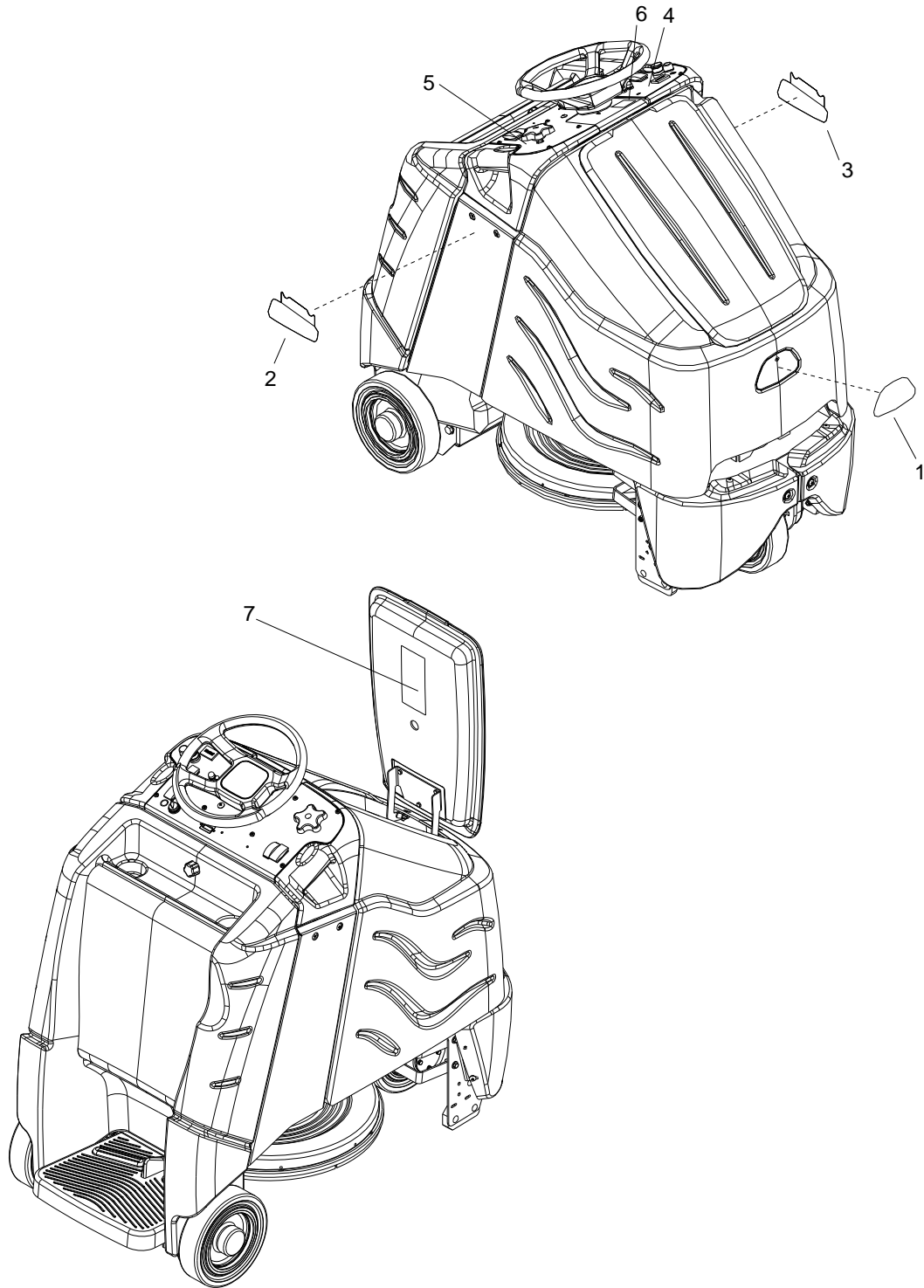

DECALS

REF	PART NO.	PRV NO.	QTY	DESCRIPTION	SERIAL NO. FROM	NOTES:
1	86004970	50990	1	LABEL, WINDSOR LOGO DOMED		
2	86244760	501224	1	DECAL, CHARIOT SIDE IGLOSS RT		
3	86244770	501225	1	DECAL, CHARIOT, SIDE IGLOSS LT		
4	86244190	500882	1	LABEL, PANEL BASIC LEFT		
5	86244290	500943	1	LABEL, PANEL DECAL , RH		
6	86243990	500780	1	LABEL, COVER PANEL		
7	86244350	501050	1	LABEL, PAD ALIGNMENT		

NOTE: See "SAFETY LABEL LOCATION" page for safety label information.

FILTER

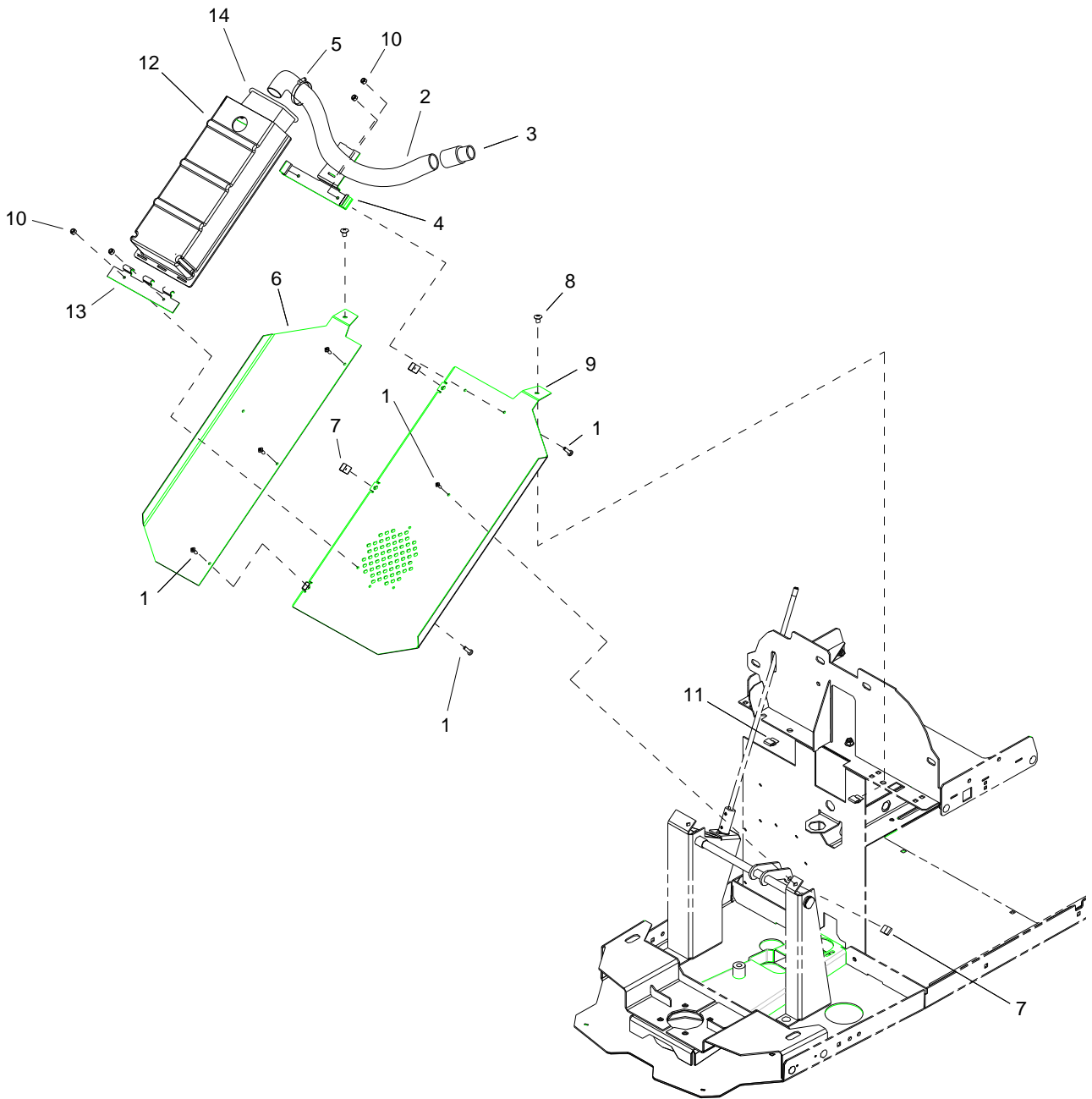

FILTER

REF	PART NO.	PRV NO.	QTY	DESCRIPTION	SERIAL NO. FROM	NOTES:
1	86006590	70088	6	SCR, 10-32 X 1/2 PPHMS SS		
2	86270320	39729	1	HOSE ASM, 1.5 BLK VAC X 36		
3	86002840	27282	1	CUFF, 1.5 SLIP X 1.5 HOSE		
4	86072500	14398	1	BRKT, FILTER COVER LATCH		
5	86002380	20046	1	CLAMP, 2.25" WORM GEAR		
6	86079280	620094	1	PLATE, FAN/BAG, MOUNT		
7	86270970	57081	5	NUT, 10-32 CAPTIVE J-TYPE		
8	86276890	70752	2	SCR, 5/16-18 X 3/4 PTHMS SS		
9	86079250	620091	1	PLATE, FAN/BAG MOUNT		
10	86270990	57090	4	NUT, 10-32 HEX NYLOCK SS		
11	86271820	57270	2	NUT, 5/16-18 CAPTIVE "J" PLTD		
12	86063790	27880	1	COVER FILTER		
13	86072510	14399	1	BRKT, FILTER COVER HINGE		
14	86284870	2003SM	-	SM FILTER BAG PACKS 10/PKG		

FRAME-LOWER

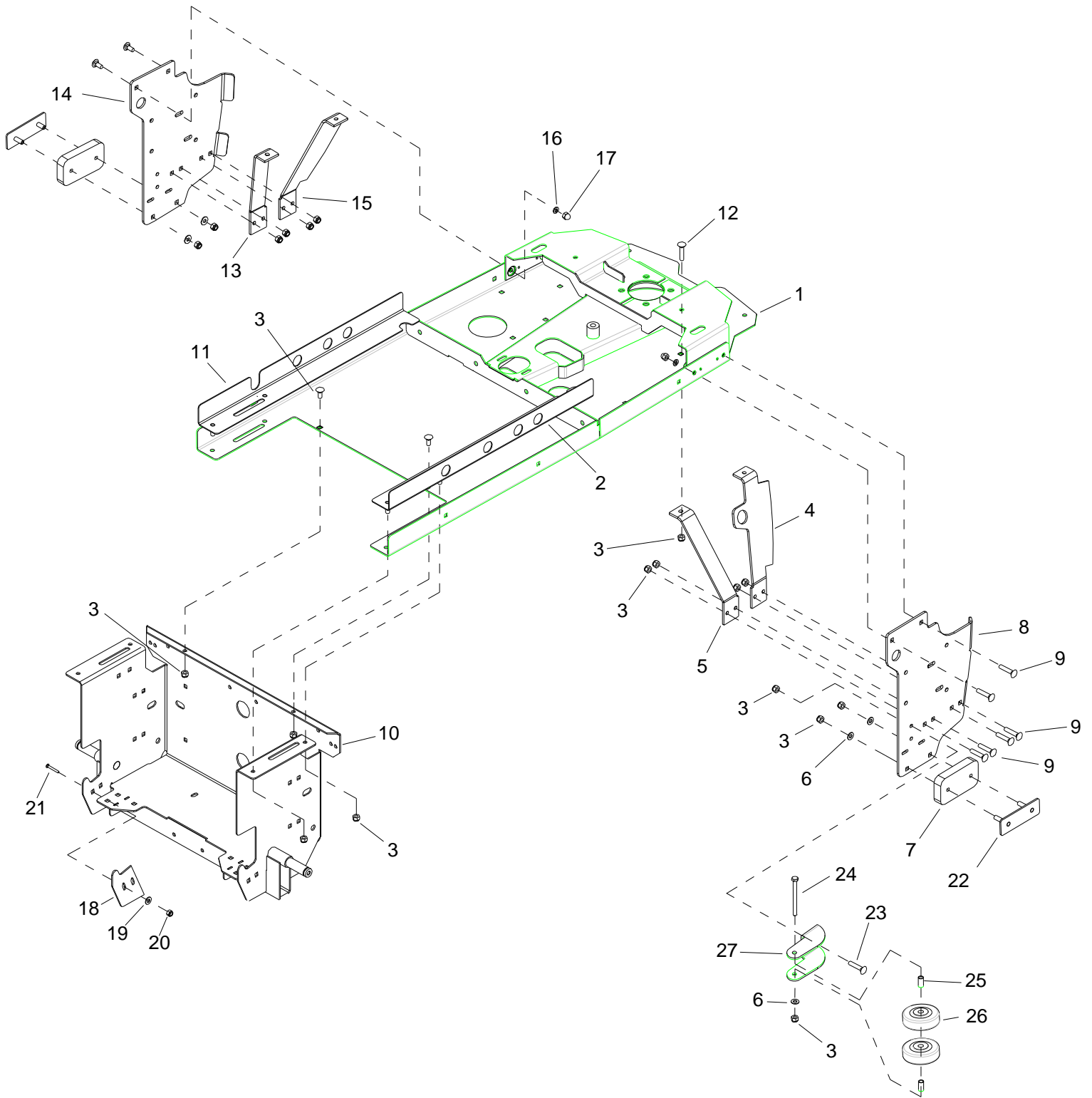

FRAME-LOWER

REF	PART NO.	PRV NO.	QTY	DESCRIPTION	SERIAL NO. FROM	NOTES:
1	86300060	-	1	FRAME, MAIN ASM		WAS 34440
2	86088760	75458	1	TRAY, SLIDE, LEFT		
3	86270830	57023	21	NUT, 5/16-18 HEX NYLOCK SS		
4	86071430	140863	1	BRKT, BRACE, RGT FRONT		
5	86071120	140811	1	BRKT, TIP BRACE, RIGHT, REAR		
6	86010670	87029	5	WASHER, 5/16 FLAT SS		
7	86064300	140790	2	PAD, TIPPING BAR		
8	86070740	140730	1	BRKT, LINKAGE, RIGHT		
9	86276070	70593	16	SCR, 5/16-18 X 3/4 CARRIAGE SS		
10	86091420	05251	1	AXLE, REAR WELDMENT		
11	86088750	75457	1	TRAY, SLIDE, RIGHT		
12	86277470	70848	6	SCR, 5/16-18 X 1.5 CARRIAGE SS		
13	86071130	140812	1	BRKT, TIP BRACE, LEFT, REAR		
14	86070750	140731	1	BRKT, LINKAGE, LEFT		
15	86070760	140733	1	BRKT, BRACE, LEFT FRONT		
16	86279130	87083	4	WASHER, 5/16 SPLIT LICK PLTD		
17	86197040	57264	4	NUT, 5/16-18 HEX ACORN PLTD		
18	86079290	620097	2	PLATE, REAR COVER ADJ.		
19	86010630	87013	4	WASHER, 1/4 ID X 5/8 OD SS		
20	86271870	57290	4	NUT, 1/4-20 HEX NYLOCK THIN SS		
21	86276950	70772	4	SCR, 1/4-20 X 3/4 CARRIAGE SS		
22	86079320	620101	2	PLATE, PAD RETAINER		
23	86277130	70795	2	SCR, 5/16-18 X 1.00 CARRIAGE SS		
24	86276910	70754	1	SCR, 5/16-18 X 3 HHCS SS NP		
25	86001350	140390	2	BUSHING, SPANNER .435 X 1.10		
26	86011020	89202	2	WHEEL, 3" DIA CUSHION RUBBER		
27	86300100	-	1	BRKT, WHEEL MOUNT		

FRAME-UPPER

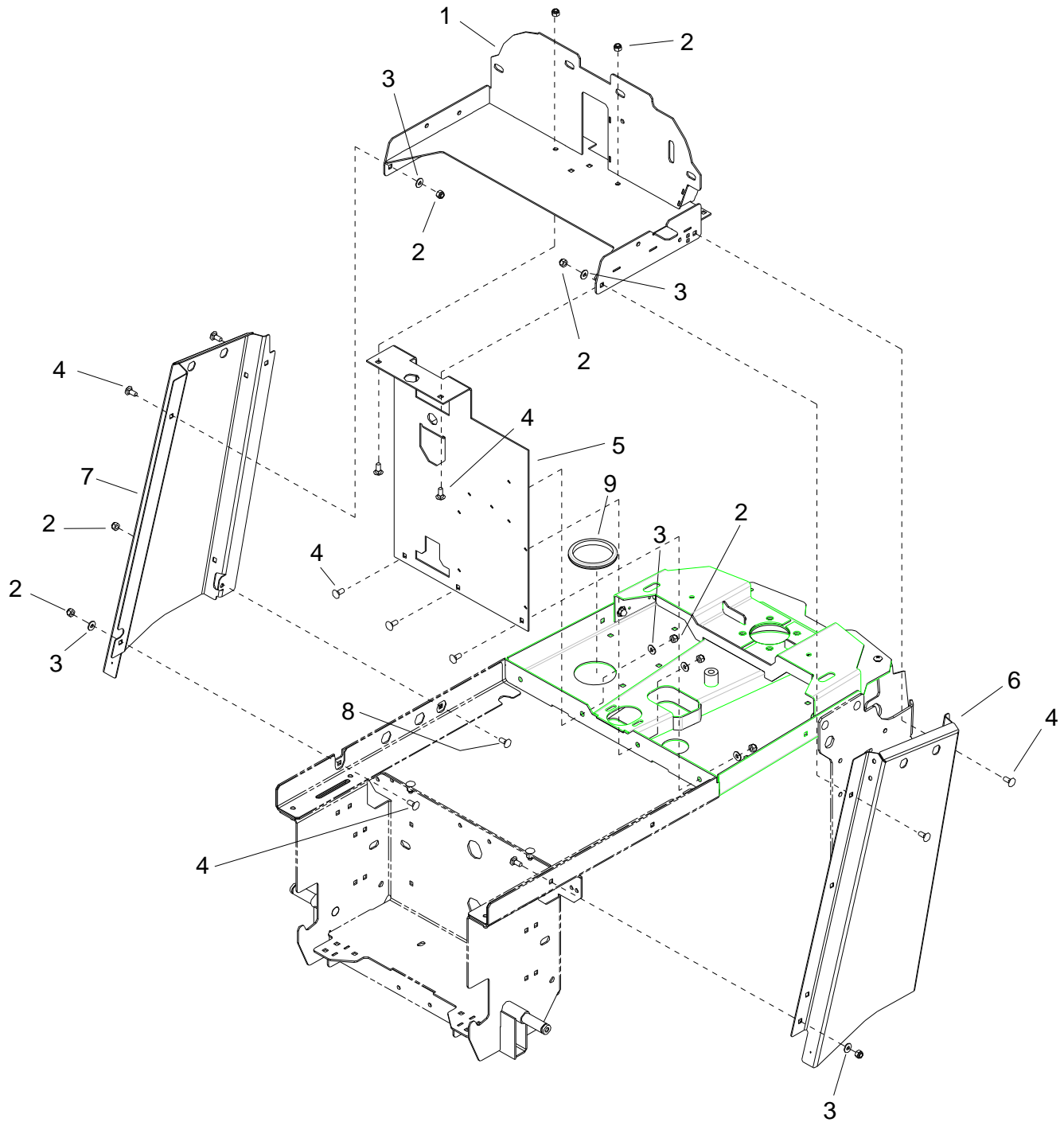

FRAME-UPPER

REF	PART NO.	PRV NO.	QTY	DESCRIPTION	SERIAL NO. FROM	NOTES:
1	86071360	140855	1	BRKT, HORIZ ELECT, BURNISHER		
2	86270830	57023	10	NUT, 5/16-18 HEX NYLOCK SS		
3	86010670	87029	9	WASHER, 5/16 FLAT SS		
4	86276070	70593	9	SCR, 5/16-18 X 3/4 CARRIAGE SS		
5	86292100	-	1	PLATE VERTICAL SUPPORT		
6	86074160	270101	1	CHANNEL, RIGHT DELUXE		
7	86073500	270090	1	BRKT, SIDE CHANNEL L		
8	86277460	70847	2	SCR, 5/16-18 X 5/8 BSHCS SS		
9	86238450	36245	1	GROMMET, 3.0 ID X 3.25 GROOVE		

HOOD

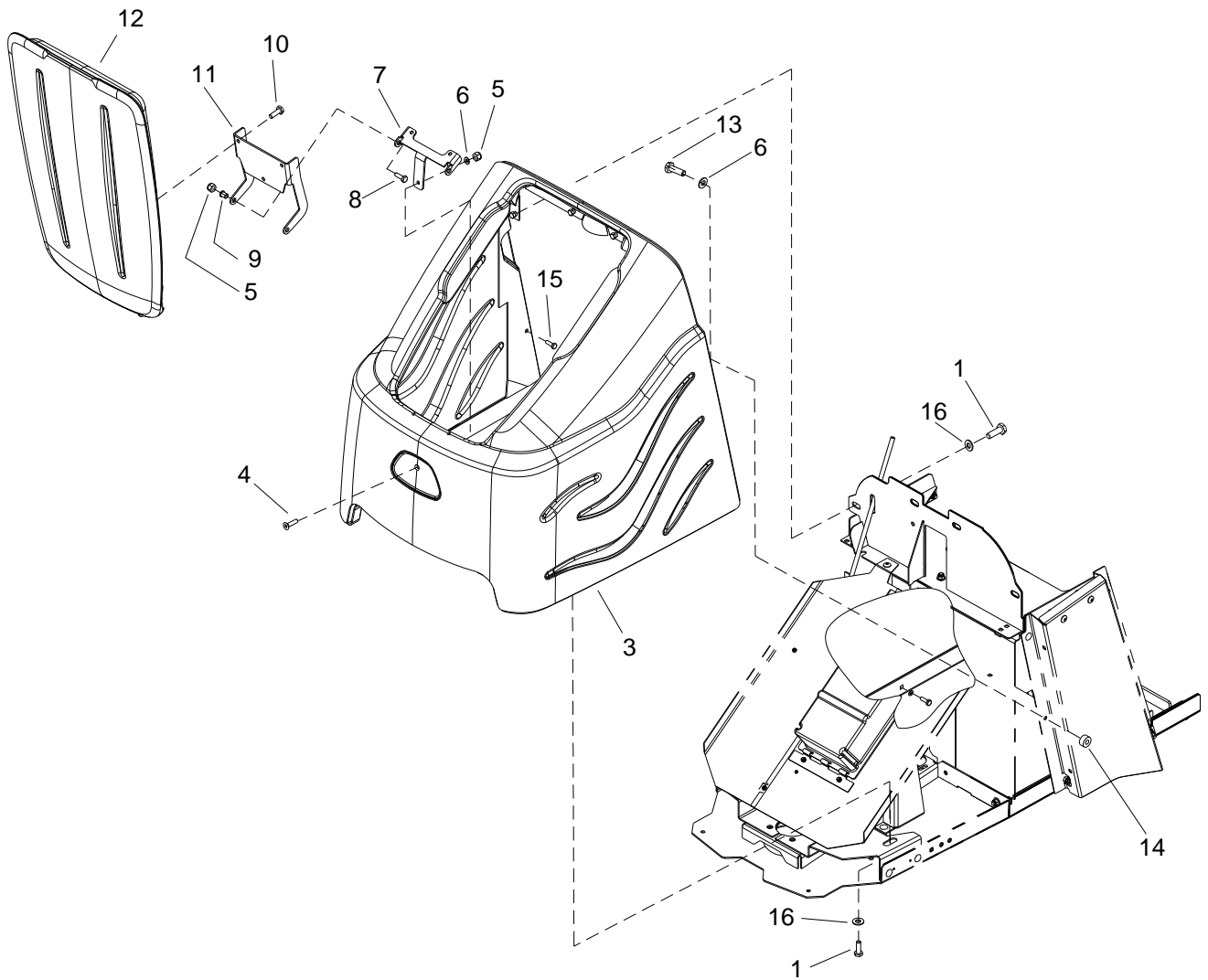

HOOD

REF	PART NO.	PRV NO.	QTY	DESCRIPTION	SERIAL NO. FROM	NOTES:
1	86274460	70205	6	SCR, 1/4-20 X 3/8 HHCS PLT		
2	OPEN	-	-	-		
3	86032920	75482	1	TANK, VACUUM BODY COVER		
4	86006840	70390	3	SCR, 1/4-20 X 1 FHCS PLTD		
5	86005810	57245	5	NUT, 1/4-20 HEX NYLOCK SS		
6	86010630	87013	5	WASHER, 1/4 ID X 5/8 OD SS		
7	86076710	41533	1	HINGE, TANK		
8	86273780	70015	2	SCR, 1/4-20 X 3/4 HHCS SS NP		
9	86226370	14493	2	BUSH, BRZ FLG .25 X .38 X .38		
10	86273830	70020	3	SCR, 1/4-20 X 1/2 HHCS SS		
11	86076720	41534	1	HINGE, LID		
12	86031140	51408	1	LID, BURNISHER		
13	86275570	70505	2	SCR, 1/4-20 X 1 HHCS GR5 PLTD		
14	86254280	730331	2	SPACER, 1.00 OD X .321ID X .375		
15	86250250	66286	2	PLUSNUT, 1/4-20 FLATHEAD		
16	86279630	87212	6	WASHER, .344 ID X 1.13 OD X .09 T PLT		

PEDAL PLATFORM-From Serial Number (4*)

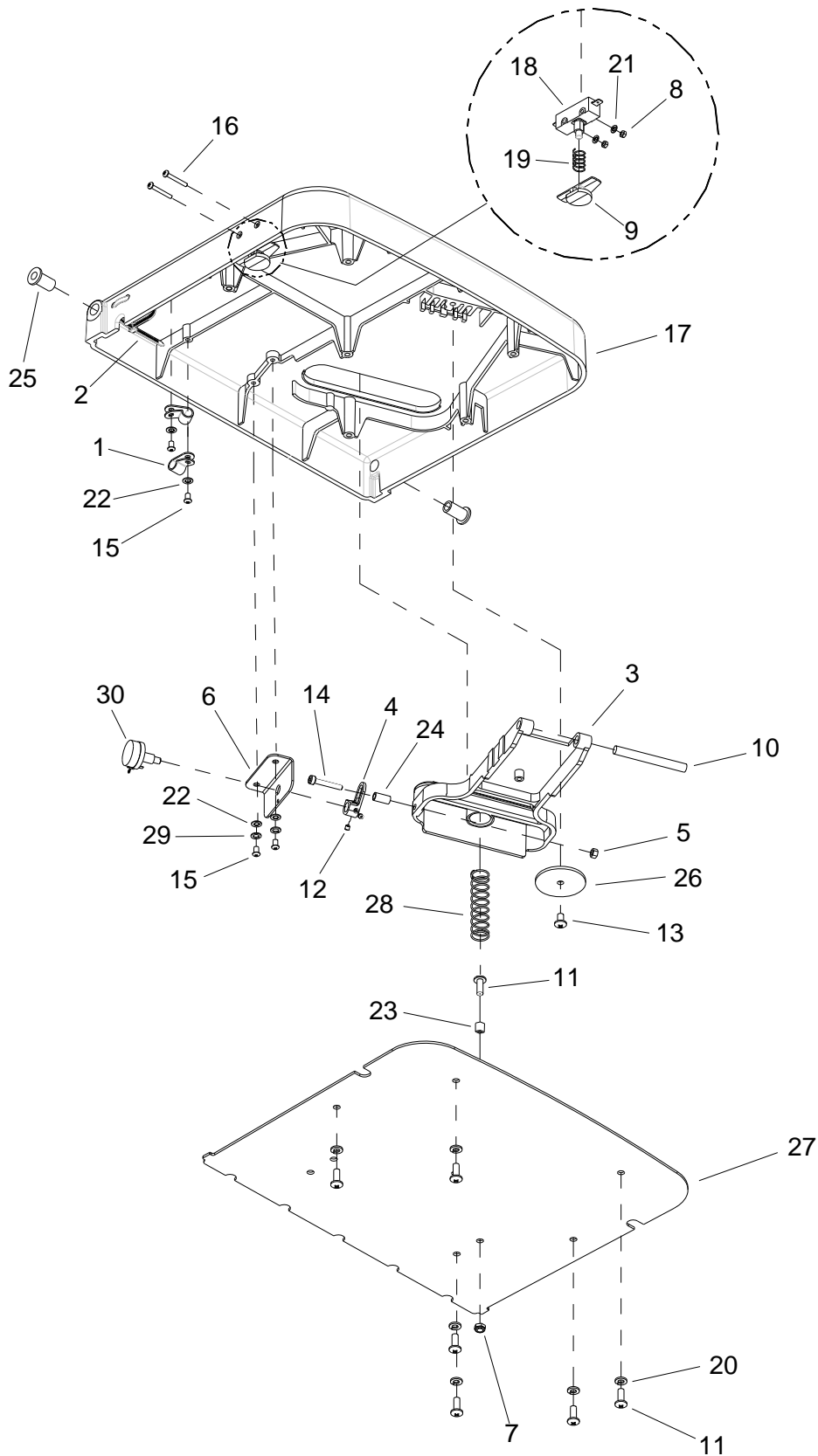

PEDAL PLATFORM-From Serial Number (4*)

REF	PART NO.	PRV NO.	QTY	DESCRIPTION	SERIAL NO. FROM	NOTES
1	86233170	20054	2	CLAMP, 3/8 NYLON UL/CSA		
2	86264920	27049	1	CABLE TIE, .19 X 7 UL/CSA		
3	86222510	34430	1	PEDAL, THROTTLE		
4	86221850	34433	1	LINK, THROTTLE		
5	86136310	57086	1	NUT, M5 HEX		
6	86312820	-	1	BRACKET, POT, SPEED		
7	86288720	57277	1	NUT, M6 NYLOCK PLATED		
8	86272040	57503	2	NUT, M3.5 X 2.8 HEX		
9	86223260	66085	1	PLUNGER, PLATFORM SWITCH		
10	86223580	67502	1	ROD, PIVOT, 8.5MM X 77		
11	86274340	70179	7	SCR, M6 X 16 PH		
12	86278060	70759	2	SET SCR, M4 X 4MM NP		
13	86277360	70833	1	SCR, M6 X 10 PH		
14	86277370	70834	1	SCR, M5 X 30 SHCS		
15	86277380	70835	4	SCR, M4.8 X 16 PHTF		
16	86277390	70836	2	SCR, M3.5 X 38 PH		
17	86312770	-	1	PLATFORM		
18	86007110	72123	1	SWITCH, 25A SPST 125-250V SNAP		
19	86224750	73993	1	SPRING, COMP, .48OD X .91L		
20	86279140	87085	6	WASHER, M6 SPLIT LOCK DIN127B		
21	86279720	87248	2	WASHER, M4 INT STAR		
22	86279730	87249	4	WASHER, M5 INT STAR		
23	86224360	730325	1	SPACER 12.7MMOD X 2.78W X 6L		
24	86224350	730305	1	SPACER, 8MM X 16LG		
25	86333280	-	2	BUSHING, 8MM X 10 LG SS		
26	86222780	620047	1	PLATE, PIVOT		
27	86222810	620050	1	PLATE, COVER		
28	86254970	730304	1	SPRING, COMP 18MM OD X 83 X 2		
29	86137300	87084	2	WASHER, M5 SPLIT LOCK PLTD		
30	86250280	66135	1	POTENTIOMETER 5K OHMS		

NOTE: Complete platform assembly is available, Part No. 86028310.

**CALL MANUFACTURER FOR SERIAL NUMBER

***SEE SERIAL NUMBER PAGE.**

PEDAL PLATFORM-To Serial Number (4*)

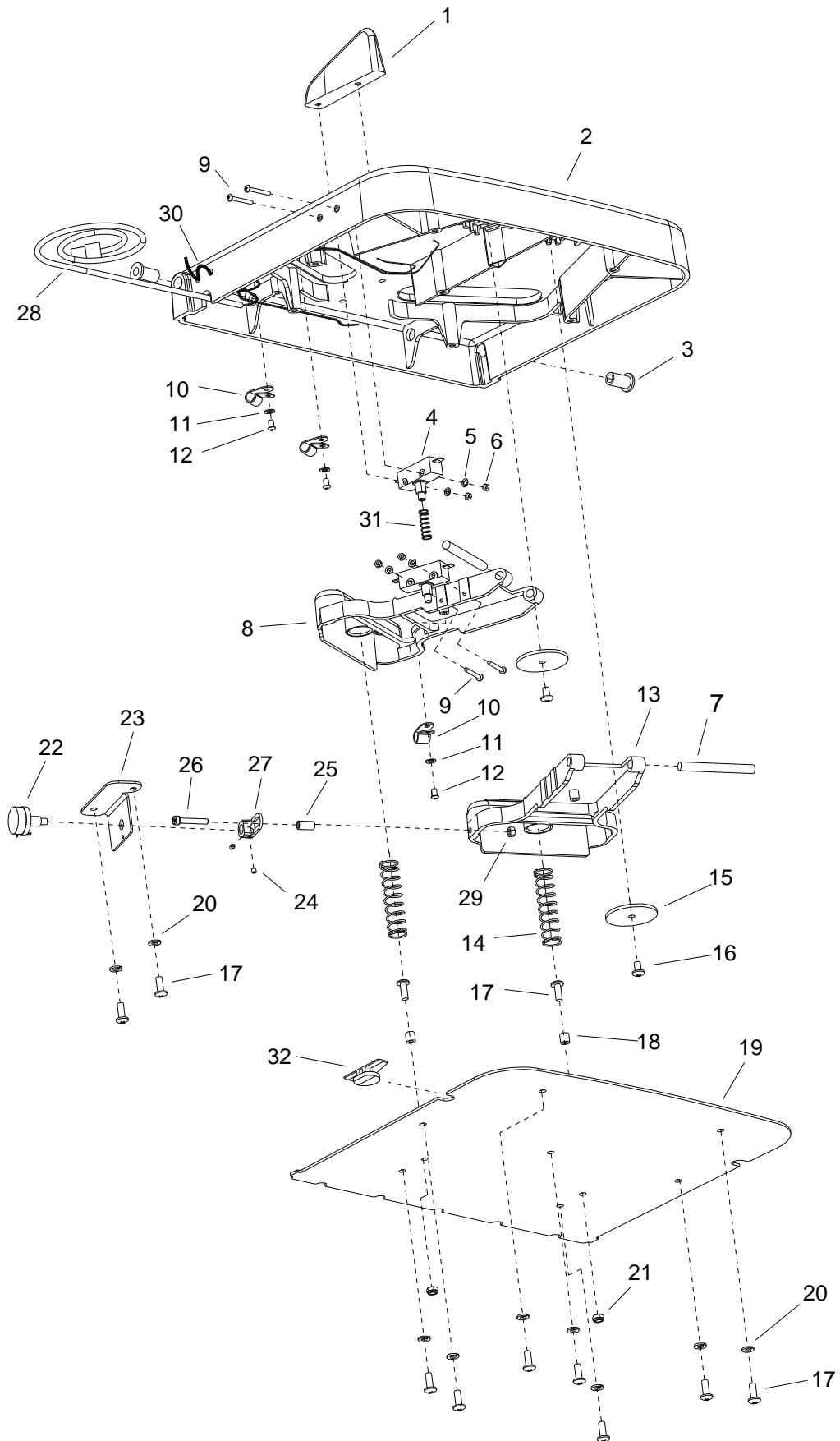

PEDAL PLATFORM-To Serial Number (4*)

REF	PART NO.	PRV NO.	QTY	DESCRIPTION	SERIAL NO. FROM	NOTES:
1	86217650	34432	1	DIVIDER		
2	86222700	34429	1	PLATFORM		
3	86216380	140713	2	BUSHING, 8MM X 10LG CLY		
4	86007110	72123	2	SWITCH, 25A SPST 125-250V SNAP		
5	86279720	87248	4	WASHER, M4 INT STAR		
6	86272040	57503	4	NUT, M3.5 X 2.8 HEX		
7	86223580	67502	2	ROD, PIVOT, 8.5MM X 77		
8	86222520	34431	1	PEDAL, BRAKE		
9	86277390	70836	4	SCR, M3.5 X 38 PHMS		
10	86079000	20054	3	CLAMP, 3/8 NYLON UL/CSA		
11	86279730	87249	4	WASHER, M5 INT STAR		
12	86204290	70835	4	SCR, M4.8 X 16 PHTF		
13	86222510	34430	1	PEDAL, THROTTLE		
14	86254970	730304	2	SPRING, COMP 18MM OD X 83 X 2		
15	86222780	620047	2	PLATE, PIVOT		
16	86277360	70833	2	SCR, M6 X 10 PH		
17	86274340	70179	11	SCR, M6 X 16 PH		
18	86224360	730325	2	SPACER 12.7MM ID X 2.78W X 6L		
19	86911060	620050	1	PLATE, COVER		
20	86279140	87085	9	WASHER, M6 SPLIT LOCK DIN127B		
21	86288720	57277	2	NUT, M6 NYLOCK PLATED		
22	86250270	66135	1	POTENTIOMETER, 5K OHMS		
23	86222790	620048	1	PLATE, THROTTLE		
24	86278060	70759	2	SET SCR, M4 X 4MM NP		
25	86224350	730305	1	SPACER, 8MM 16L		
26	86277370	70834	1	SCR, M5 X 30 SHCS		
27	86221850	34433	1	LINK, THROTTLE		
28	86218810	23717	1	HARNESS, TWISTER PEDAL		
29	86136310	57086	1	NUT, M5 HEX		
30	86264920	27049	1	CABLE TIE, 7" UL/CSA		
31	86224750	73993	1	SPRING, COMP, .480D X .91		
32	86223260	66085	1	PLUNGER, PLATFORM SWITCH		

***SEE SERIAL NUMBER PAGE.**

PEDAL PLATFORM

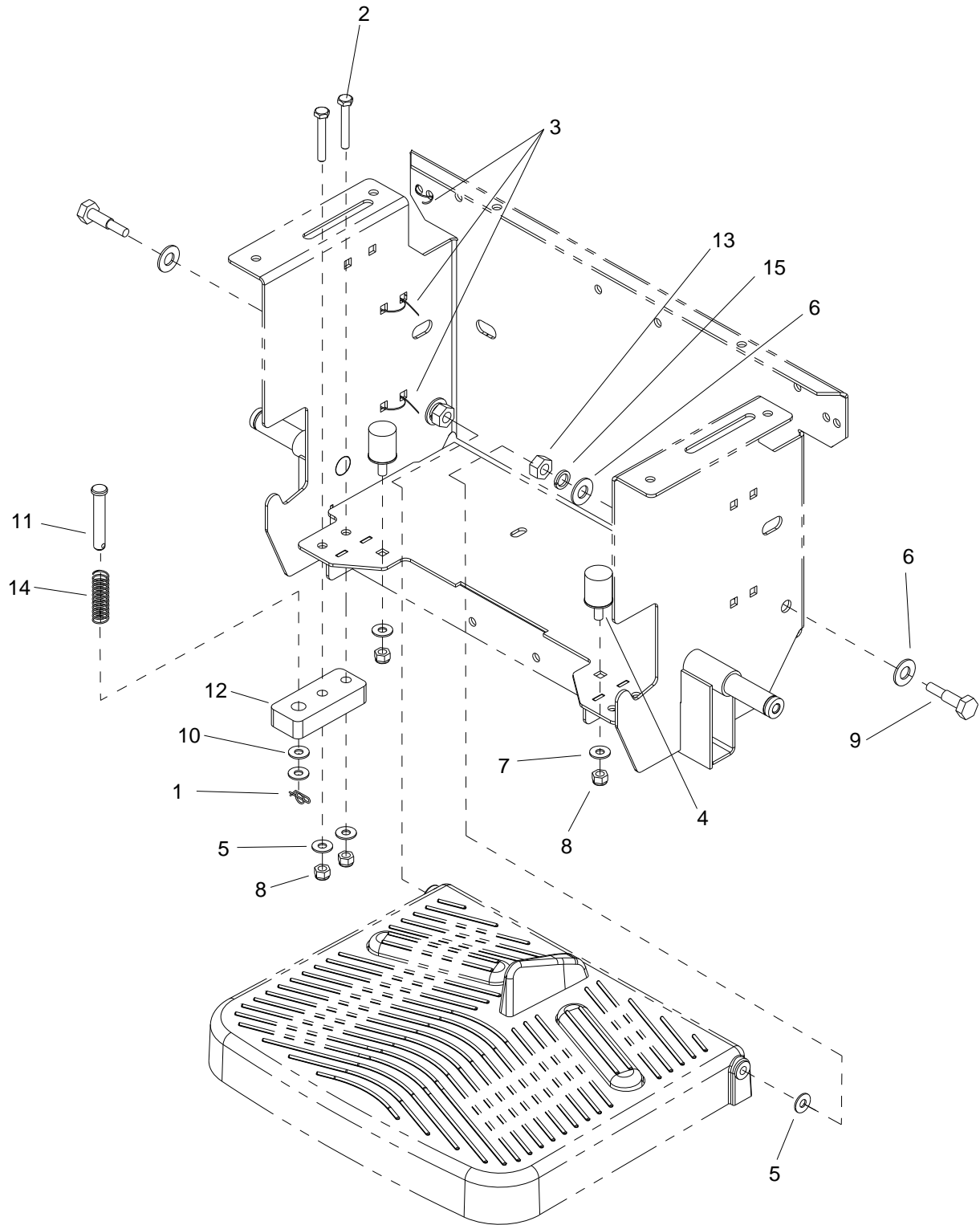

PEDAL PLATFORM

REF	PART NO.	PRV NO.	QTY	DESCRIPTION	SERIAL NO. FROM	NOTES:
1	86008680	80607	1	COTTER, 1/2" RING		
2	86274690	70258	2	SCR, 5/16-18 X 1.5 HHCS GR5PLT		
3	86264920	27049	3	CABLE TIE, 7" UL/CSA		
4	86231070	730328	2	BUMPER, 1 X 1.375 RUBBER		
5	86010670	87029	5	WASHER, 5/16 FLAT SS		
6	86259430	87485	4	M12 FLAT WASHER		
7	86010770	87143	2	WASHER, 7/16ID X1D.08 FLT SS		
8	86270830	57023	4	NUT, 5/16-18 HEX NYLOCK SS		
9	86211280	70852	2	STUB AXLE, M12-1.75 X 45MM		
10	86278850	80613	2	WASHER, .506 ID X .94D X .064 NYL		
11	86248920	66487	1	PIN, CLEVIS 1/2 X 2.25		
12	86249560	629993	1	PLATE, SWITCH BASE		
13	86271190	57142	2	NUT, M12 X 1.75 HEX DIN934 PLT		
14	86007780	73576	1	SPRING, COMP .60D X2.0L X .045W		
15	86259440	87486	2	WASHER, M12 SPRING LOCK		

REAR COVER

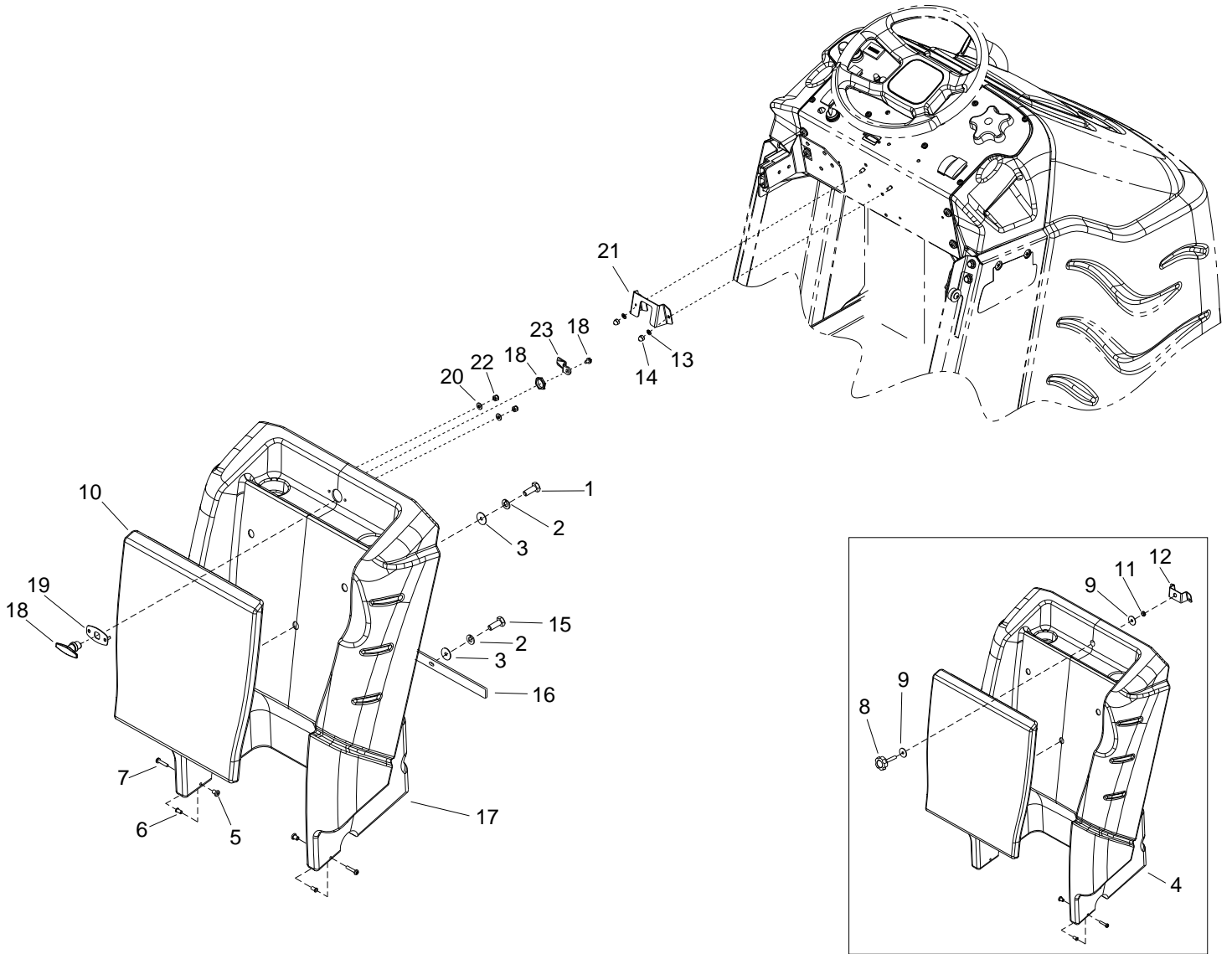

REAR COVER

REF	PART NO.	PRV NO.	QTY	DESCRIPTION	SERIAL NO. FROM	NOTES:
1	86276780	70728	3	SCR, 5/16-18 X 3/4 HHCS SS		
2	86279130	87083	5	WASHER, 5/16 SPLIT LOCK PLTD		
3	86010670	87029	5	WASHER, 5/16 FLAT SS		
4	86031780	270082	1	COVER, REAR, DELUXE		
5	86005860	57273	2	NUT, 1/4-20 X 12MM HEX BARREL		
6	86228980	09152	2	BEARING FLANGED .377ID X .505OD		
7	86275870	70556	2	SCR, 1/4-20 X 1.5" PPHMS SS		WAS 70697
8	86242140	72193	1	KNOB, 3/8-16 X 1.5		
9	86010770	87143	2	WASHER, 7/16ID X 1D X .08FLT SS		
10	86248380	66433	1	PAD, FLAT LEANING		
11	86005630	57022	1	NUT, 3/8-16 HEX NYLOCK THIN SS		
12	86071030	140786	1	BRKT, ASSEMBLY, REAR COVER		
13	86010780	87162	2	WASHER, 1/4 SPLIT LOCK		
14	86271940	57299	2	NUT, 1/4-20 ACORN SS		
15	86006560	70083	2	SCR, 5/16-18 X 1 HHCS SS		
16	86066940	140891	1	BAR, COVER		
17	86324320	-	1	REAR COVER, DELUXE	*(3)	
18	86324640	-	1	HANDLE, CAM LATCH	*(3)	
19	86324760	-	1	PLATE, COVER LATCH	*(3)	
20	86010630	87013	2	WASHER, 1/4 ID X 5/8 OD SS	*(3)	
21	86324340	-	1	BRKT, REAR COVER	*(3)	
22	86005810	57245	2	NUT, 1/4-20 HEX NYLOCK SS	*(3)	
23	86324650	-	1	PAWL, HANDLE	*(3)	

*See Serial Number Page

DECK LIFT MECHANISM

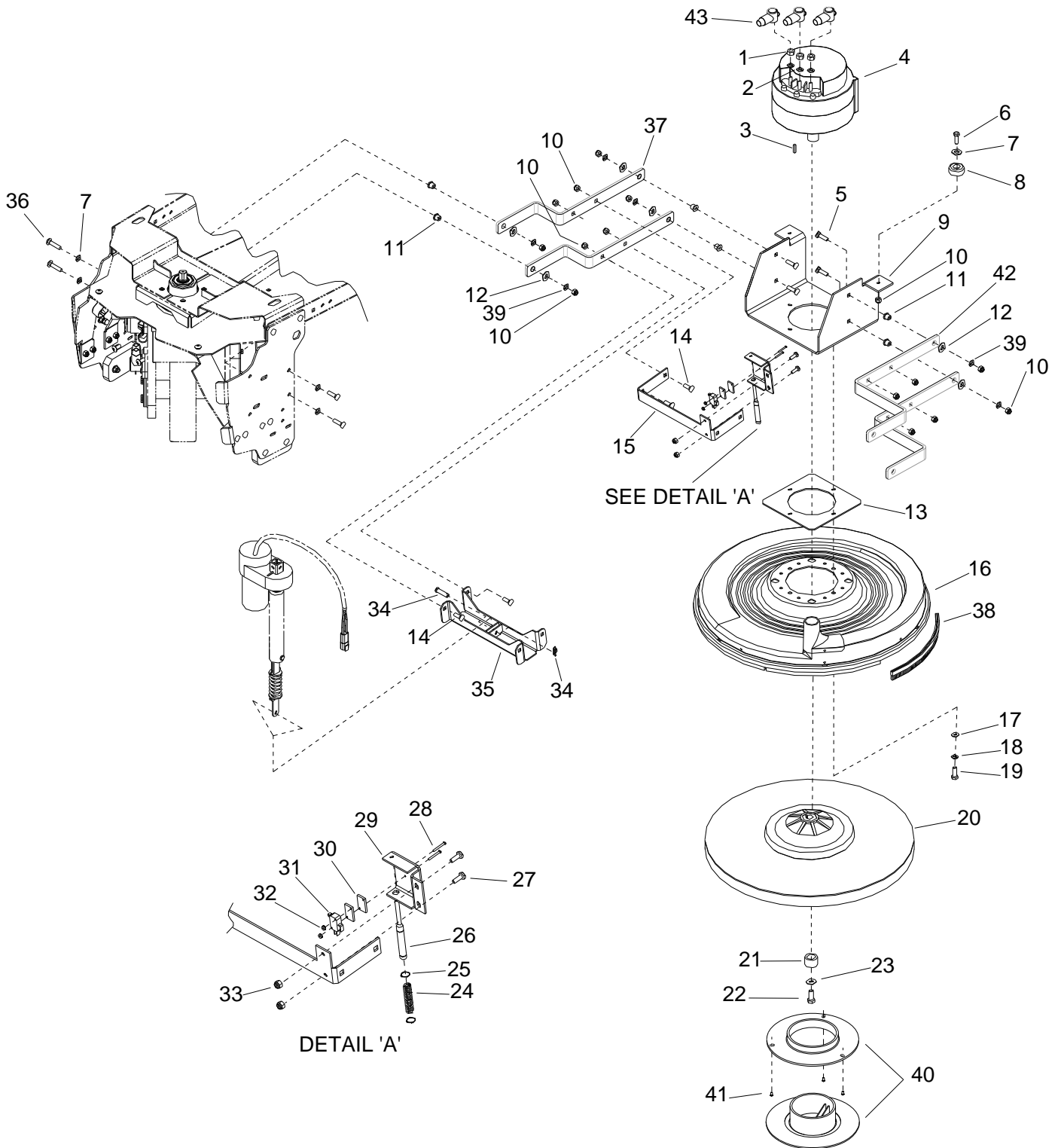

DECK LIFT MECHANISM

REF	PART NO.	PRV NO.	QTY	DESCRIPTION	SERIAL NO. FROM	NOTES:
1	86271840	57285	3	NUT, 5/16-18 HEX NYLOCK THIN SS		
2	86279130	87083	3	WASHER, 5/16 SPLIT LOCK PLTD		
3	86135970	48045	1	KEY, 3/16 SQ X 5/8 LONG		
4	86028170	53269	1	MOTOR, 36VDC 4HP 2000RPM		
5	86277030	70780	4	SCR, 5/16-18 X 1.25 CARRIAGE SS		
6	86006560	70083	2	SCR, 5/16-18 X 1 HHCS SS		
7	86010670	87029	4	WASHER 5/16 FLAT SS		
8	86231090	80809	2	BUMPER, RUBBER 5/16" ID X 1.50		
9	86071480	140868	1	BRKT, MOTOR MOUNT		
10	86270830	57023	14	NUT, 5/16-18 HEX NYLOCK SS		
11	86228840	09124	8	BEARING, FLANGED .314 ID X .502 OD		
12	86259400	87205	8	WASHER, .51 ID X 1 ODBRO		
13	86083510	66834	1	PLATE, MOTOR SPACER		
14	86277130	70795	8	SCR, 5/16-18 X 1.00 CARRIAGE SS		
15	86073440	149992	1	BRKT, SWITCH MOUNT		
16	86026450	730352	1	SHROUD, 20 IN BURNISHER		INCLUDES BRUSH STRIPS (730074)
17	86278910	87003	4	WASHER, 3/8 OD X 7/8 OD SS		
18	86010790	87163	4	WASHER, 3/8 SPLIT LOCK		
19	86276920	70755	4	SCR, 3/8-16 X 1 HHCS SS NP		
20	86248280	64110	1	PAD DRIVER ASSEM 20", .88 BORE		INCLUDES 40 & 41
21	86254310	730355	1	SPACER, BURNISHER HUB		
22	86277540	70863	1	SCR, 7/16-20 X 1 HHCS PLTD		
23	86010710	87080	1	WASHER, .5 X 1.25 FLAT GR8 PLTD		
24	86007780	73576	1	SPRING, COMP .60D X 2.0L X .045W		
25	86270270	27721	2	CLIP, RETAINING 7/16		
26	86223270	66482	1	PLUNGER, MICRO SWITCH		
27	86276950	70772	2	SCR, 1/4-20 X 3/4 CARRIAGE SS		
28	86276010	70580	2	SCR, 4-40 X 1.0 PPHMS		
29	86072460	14387	1	BRKT, MIRCOSWITCH MOUNT		
30	86087520	73456	2	SPACER, PLUNGER SWITCH		
31	86007160	72157	1	SWITCH, 10A ROLLER MINI		
32	86271280	57163	2	NUT, 4-40 W/STAR WASHER		
33	86005810	57245	2	NUT, 1/4-20 HEX NYLOCK SS		
34	86008670	80606	2	COTTER, 3/8" RING		
35	86071470	140867	1	BRKT, HEAD ATTACH		
36	86007020	70673	4	SCR, 5/16-18 X 1.25 HHCS SS		
37	86300120	-	2	BRKT, HEAD ATTACH RT.		
38	86216230	730074	-	BRUSH, STRIP (PACKAGE OF 6)		
39	86279650	87222	8	WASHER, SEAL 5/16 X 3/4 OD SS		
40	86226930	51419	-	LOCK, PAD DRIVER YELLOW		
41	86161960	70222	-	SCR, #8 X 1/2 PPHST BLK		
42	86300130	-	2	BRKT, HEAD ATTACH LT.		
43	86008920	80889	3	BOOT, RUBBER TERM. ISOLATOR	**	

*SEE SERIAL NUMBER PAGE

** CALL MANUFACTURER FOR SERIAL NUMBER

DECK LIFT LINKAGE

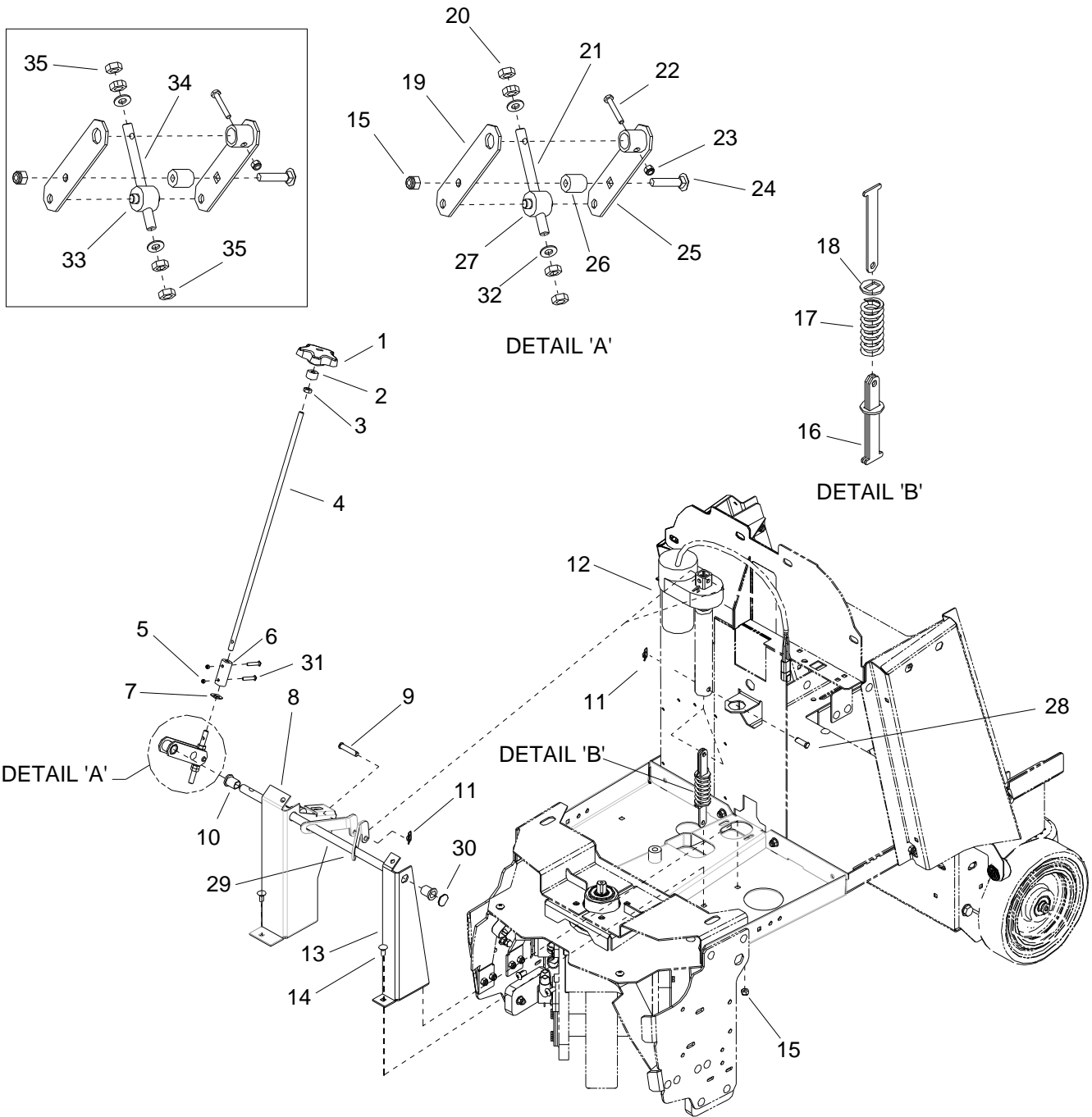

DECK LIFT LINKAGE

REF	PART NO.	PRV NO.	QTY	DESCRIPTION	SERIAL NO. FROM	NOTES:
1	86004870	48077	1	KNOB, 3.50 OD X 3/8-16 THRU HOLE		
2	86254590	81247	1	SPACER, .500 OD X .391 ID X .300		
3	86005690	57085	1	NUT, 3/8-16 HEX JAM		
4	86253260	730348	1	SHAFT, PAD ADJ, UPPER		
5	86270990	57090	2	NUT, 10-32 HEX NYLOCK SS		
6	86234620	270107	1	COUPLER, PAD ADJ		
7	86259410	87206	1	WASHER, THRUST .51 ID X 1 OD X .063		
8	86071330	140846	1	BRKT, ARM SUPPORT RT		
9	86248980	81438	1	PIN, CLEVIS 3/8 X 1.75 PLTD		
10	86231330	14664	2	BUSH, BRZ FLG .63 X .75 X 1.0		
11	86008670	80606	1	COTTER, 3/8" RING		
12	86012130	-	1	ACTUATOR, 36VDC DBLSPD, NOOK		
13	86071320	140845	1	BRKT, ARM SUPPORT LFT		
14	86276070	70593	2	SCR, 5/16-18 X 3/4 CARRIAGE SS		
15	86270830	57023	5	NUT, 5/16-18 HEX NYLOCK SS		
16	86066980	149990	3	BAR, COMP. SPRING RETAINER		
17	86255100	73443	1	SPRING, DIE COMP. 1.25 OD X 3.0 LG		
18	86090360	87492	2	WASHER, SPRING RETAINER		
19	86078730	51412	1	PLATE ADJUSTMENT ROD		
20	86316620	-	4	NUT, 3/8-16 LG THN HEX SS	*(1)	
21	86316630	-	1	SHAFT, PAD ADJ. LOWER 3/8-16	*(1)	
22	86273820	70019	1	SCR, 1/4-20 X 1.25 HHCS		
23	86005810	57245	1	NUT, 1/4-20 HEX NYLOCK SS		
24	86277470	70848	1	SCR, 5/16-18 X 1.5 CARRIAGE SS		
25	86091830	140847	1	BRKT, ADJUSTMENT ARM		
26	86254580	80835	1	SPACER, .32 ID X .71 OD X .79 L NYL		
27	86316640	-	1	PIVOT, PAD ADJ L/H THD 3/8-16	*(1)	
28	86248980	81438	1	PIN, CLEVIS 3/8 X 1.75 PLTD		
29	86300150	-	1	LINK, ACTUATOR CONTROL ARM		
30	86001660	41236	1	HUBCAP, 5/8" SHAFT		
31	86274410	70195	2	SCR, 10-32 X 1.25 PPHMS SS		
32	86010680	87030	2	WASHER, 3/8 ID X 3/4 OD NYLON		
33	86249190	66826	1	PIVOT, PAD ADJUST, L/H THD		
34	86253270	730349	1	SHAFT, PAD ADJ, LOWER		
35	86272010	57310	4	NUT, 3/8-24 LH THN HEX SS		

*SEE SERIAL NUMBER PAGE

** CALL MANUFACTURER FOR SERIAL NUMBER

STEERING

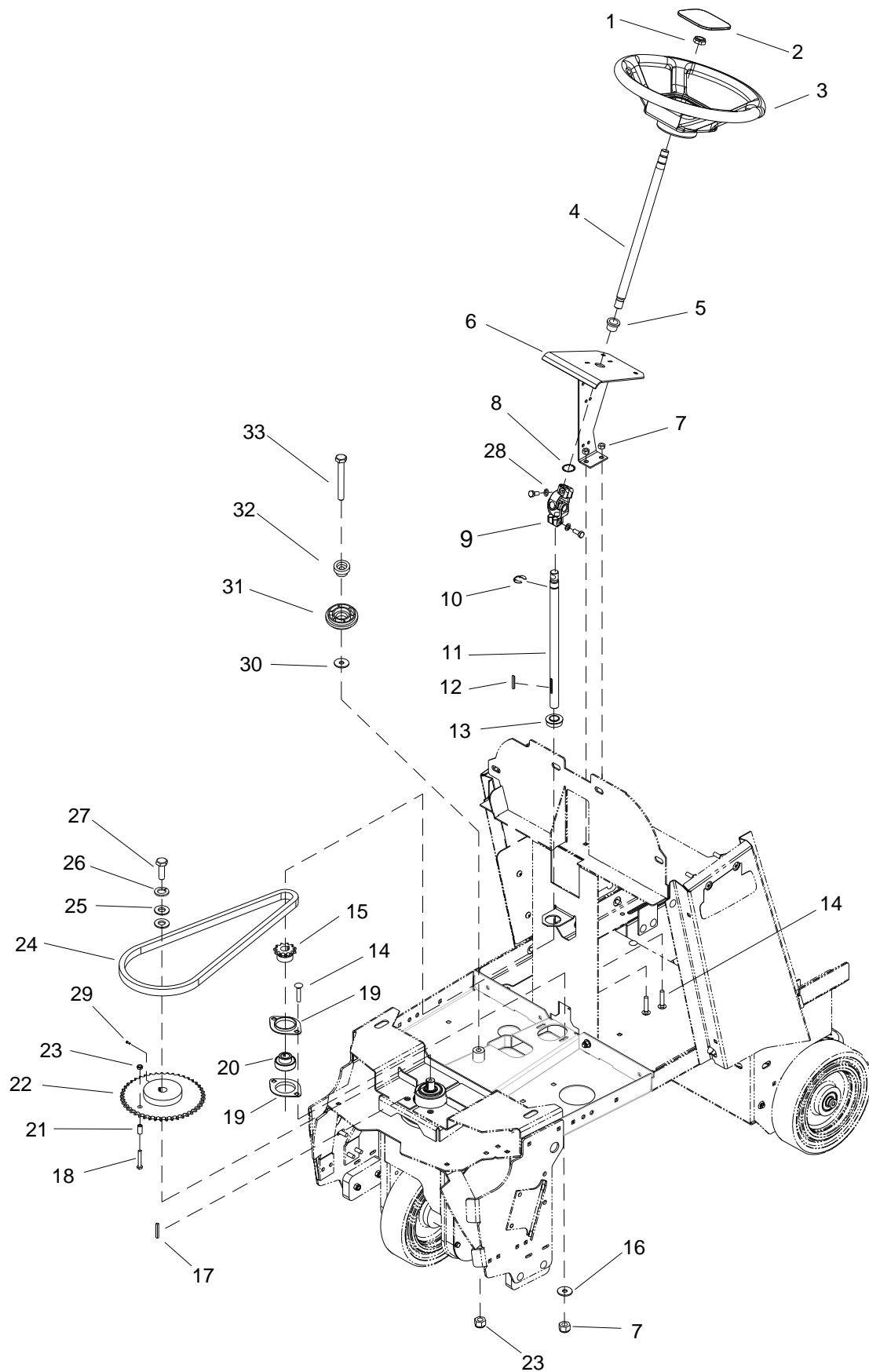

STEERING

REF	PART NO.	PRV NO.	QTY	DESCRIPTION	SERIAL NO. FROM	NOTES:
1	86271610	57228	1	NUT, 5/8-16 HEX NYLOCK THN		
2	86234810	27945	1	COVER, STEERING WHEEL		
3	86259610	730117	1	WHEEL, STEERING 40 SPLINE HUB		
4	86224050	730318	1	SHAFT, UPPER STEERING		
5	86228790	09111	1	BEARING, FLANGE .88ODX.75IDX.75		
6	86091740	140720	1	BRKT, UPPER STEERING		
7	86270830	57023	4	NUT, 5/16-18 HEX NYLOCK SS		
8	86005610	57016	1	NUT, 7/8 DIA PUSHLOCK		
9	86219600	45012	1	JOINT, UNIVERSAL FEMALE		
10	86272900	67416	1	RING, 3/4" KLIP		
11	86224060	730319	1	SHAFT, LOWER STEERING		
12	86219650	48110	1	KEY, 5MM SQ X 39MM L		
13	86228670	09072	1	BEARING, 3/4" BORE FLANGED		
14	86276070	70593	4	SCR, 5/16-18 X 3/4 CARRIAGE SS		
15	86224800	730315	1	SPROCKET, STEERING SHAFT		
16	86010670	87029	2	WASHER, 5/16 FLAT SS		
17	86135970	48045	1	KEY, 3/16 SQ X 5/8 LONG		
18	86275190	70377	1	SCR, 3/8-16 X 1.25 HHCS SS		
19	86008610	80595	2	FLANGE, BEARING PRESS STEEL		
20	86001030	09148	1	BEARING, BALL 3/4 BORE SPHERED		
21	86224320	730221	1	SPACER, .63 OD X .385ID X .64L		
22	86224810	730316	1	SPROCKET, DRIVE WHEEL STEERING		
23	86005630	57022	2	NUT, 3/8-16 HEX NYLOCK THIN SS		
24	86300190	-	1	CHAIN, 12.7MM PITCH		
25	86278940	87008	2	WASHER, 1/4 ID X 1-1/4OD		
26	86010780	87162	1	WASHER, 1/4 SPLIT LOCK PLTD		
27	86274330	70175	1	SCR, M6 X 20HHMS PLTD		
28	86279130	87083	2	WASHER, 5/16 SPLIT LOCK		
29	86253200	70806	1	SET SCR, M6 X 25 NP		SERVICE ONLY
30	86279620	87200	1	WASHER, .4 ID X 1.3 OD NYLON		
31	86002710	270076	1	CHAIN TENSIONER		
32	86224270	730293	1	SLEEVE, CHAIN TENSIONER		
33	86275990	70577	1	SCR, 3/8-16 X 3.5 SHCS PLTD		
-	86232780	279001	-	CHAIN, MASTERLINK 12.7MM		SERVICE ONLY
-	86232770	279000	-	CHAIN, OFF-SET LINK 12.7MM		SERVICE ONLY

WHEEL-FRONT DRIVE-CHAIN

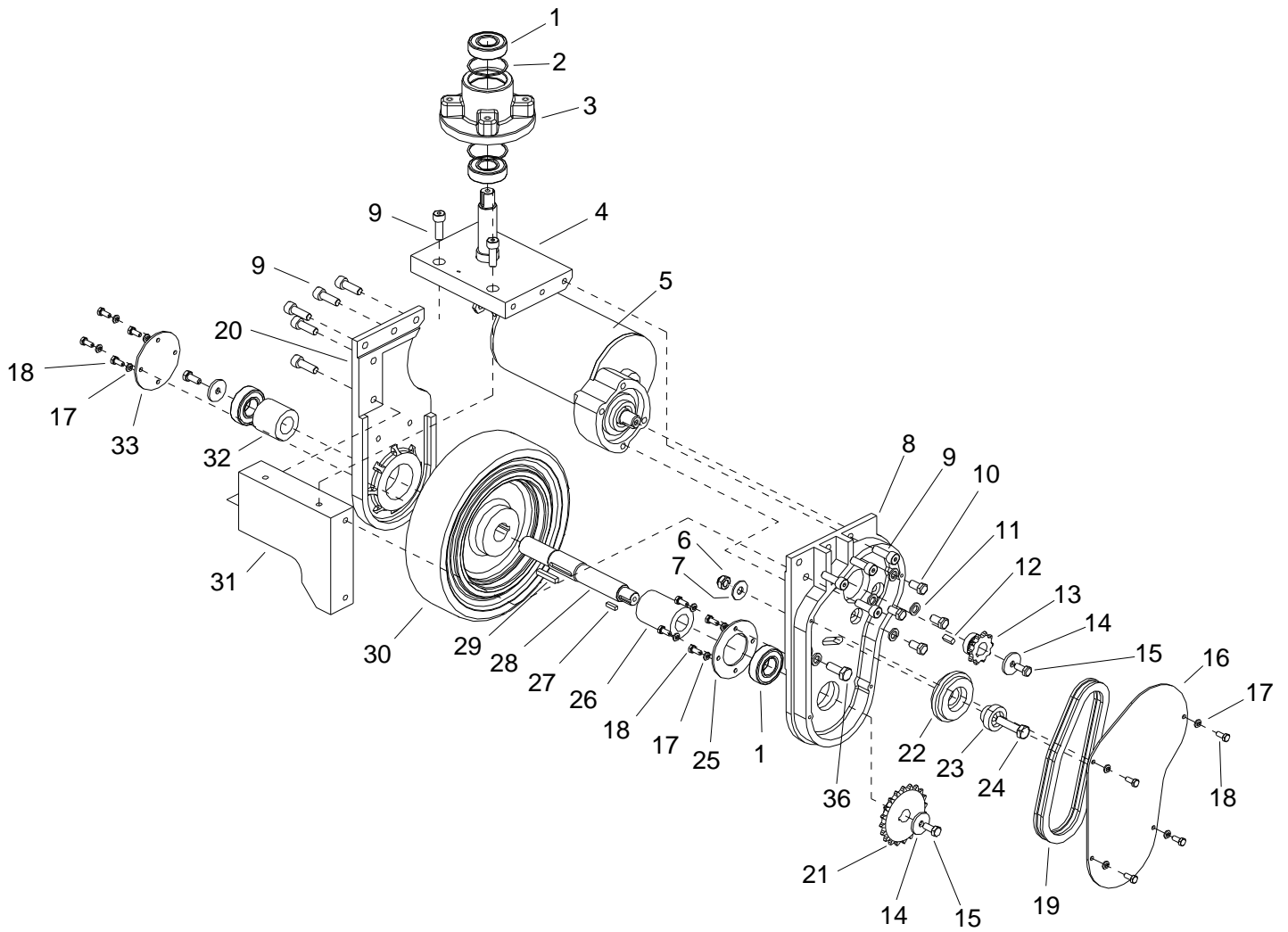

WHEEL-FRONT DRIVE-CHAIN

REF	PART NO.	PRV NO.	QTY	DESCRIPTION	SERIAL NO. FROM	NOTES:
1	86223980	09134	4	SEALED BALL BRNG, 25MM X 52MM		
2	86223480	67450	2	RING, 52MM INTERNAL SNAP		
3	86219420	41510	1	STEERING, HUB		
4	86224040	730306	1	SHAFT, ASM, DRIVE PIVOT		
5	86005510	53810	1	MOTOR, 36V 180RPM GEAR		
-	86216210	53820	-	BRUSH SET MOTOR 53810		
-	86227440	05261	1	ARMATURE 53810 MOTOR		
6	86136360	57275	1	NUT, M10X1.5 HEX NYLOCK PLTD		
7	86010720	87086	1	WASHER, M10 X 30 PLTD		
8	86222730	620038	1	PLATE, DRIVE WHEEL YOKE		
9	86318830	-	11	SCR, M10 X 30 SHCS		
10	86275640	70515	4	SCR, 3/8-24 X 3/4 HHCS GR5 PLTD		
11	86279700	87244	5	WASHER, M10 X 18 FLAT		
12	86219620	48106	1	KEY, 1/4 SQ. X .63		
13	86007620	730310	1	SPROCKET, MOTOR SHAFT		
14	86279710	87245	3	WASHER, M8 X 32 FLAT		
15	86136640	70262	2	SCR, M8-1.25 X 20HHMS PLTD		
16	86222710	620036	1	PLATE, CHAIN COVER		
17	86279690	87243	12	WASHER, M6 SPLIT LOCK		
18	86277340	70830	12	SCR, M6 X 15 HHCS		
19	86002730	270085	1	CHAIN, ISO 08B 12.7MM PITCH/LINK		
-	86232770	279000	-	CHAIN, OFF-SET LINK 12.7MM		SERVICE ONLY
-	86232780	279001	-	CHAIN, MASTERLINK 12.7MM		SERVICE ONLY
20	86222760	620041	1	PLATE, DRIVE YOKE RH		
21	86007630	730311	1	SPROCKET, DRIVE WHEEL		
22	86002710	270076	1	CHAIN TENSIONER		
23	86224270	730293	1	SLEEVE, CHAIN TENSIONER		
24	86277330	70829	1	SCR, M10 X 45 HHCS		
25	86222720	620037	1	PLATE, BEARING RETAINER		
26	86224330	730294	1	SPACER, 25.5ID X 45OD X 65L		
27	86219630	48107	1	KEY, 3/16 SQ X .67		
28	86000850	05231	1	AXLE, TWISTER		
29	86219640	48108	1	KEY, 1/4 SQ X 1.5		
30	86259940	89275	1	WHEEL, 10X2, W/KEYWY, GRY, NT		
31	86222750	620040	1	PLATE, DRIVE YOKE FRONT		
32	86224340	730295	1	SPACER, 25.5ID X 45OD X 43L		
33	86222770	620042	1	PLATE, BEARING COVER		
34	86217720	29269	-	DRIVE ASM, MOTOR		COMPLETE
35	86311040	-	1	SPACER, CHAIN DRIVE AXLE		
36	86277320	70828	1	SCR, M10 X 30 HHCS		

WHEEL-FRONT BRAKE

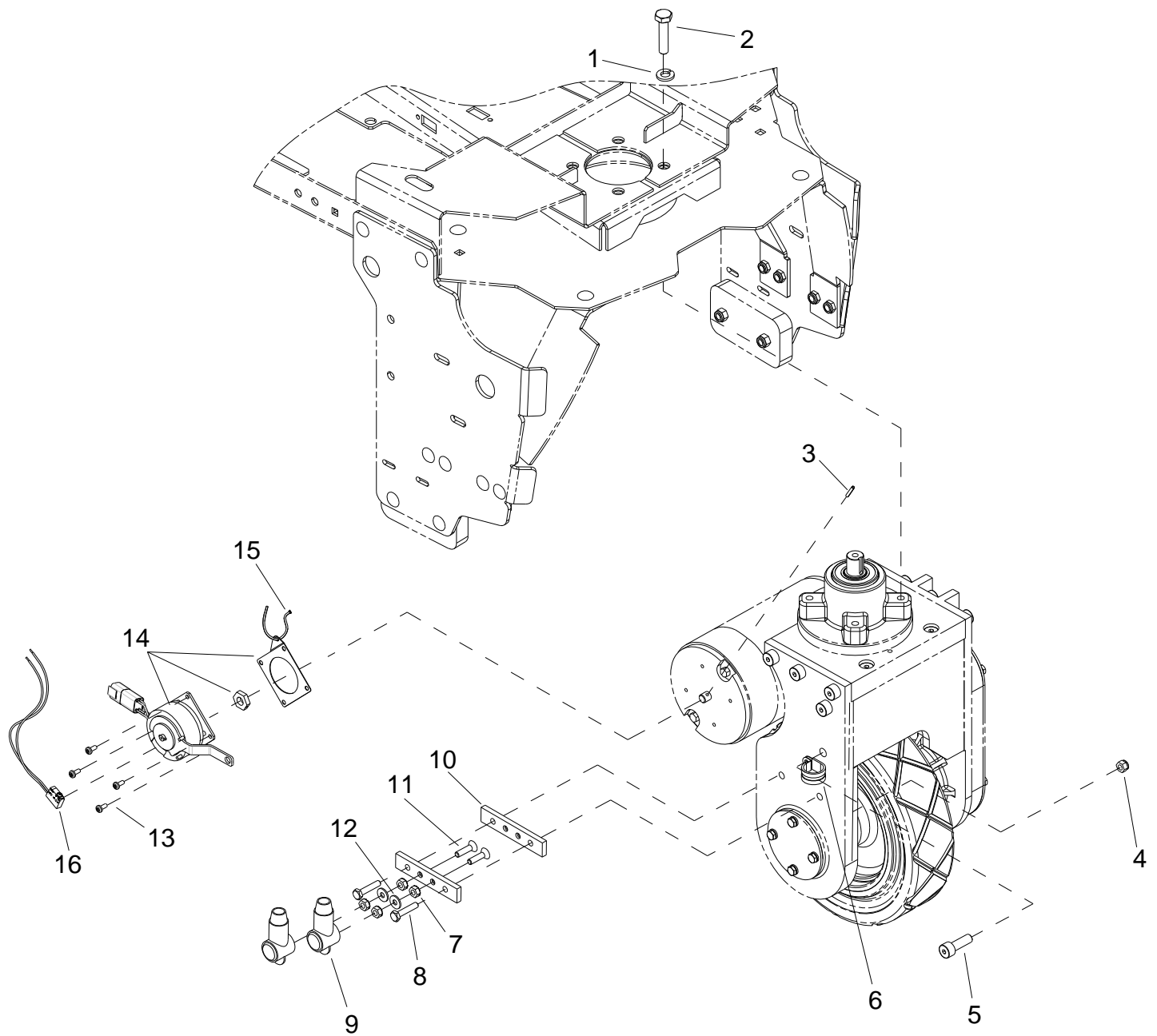

WHEEL-FRONT BRAKE

REF	PART NO.	PRV NO.	QTY	DESCRIPTION	SERIAL NO. FROM	NOTES:
1	86010790	87163	4	WASHER, 3/8 SPLIT LOCK PLTD		
2	86275190	70377	4	SCR, 3/8-16 X 1.25 HHCS SS		
3	86006170	66031	1	PIN, ROLL 1/8" X 3/4"L SS		
4	86005810	57245	2	NUT, 1/4-20 HEX NYLOCK SS		
5	86318830	-	1	SCR, M10 X 30 SHCS		
6	86233410	81270	1	CLAMP, 3/4 DIA CUSHION .406DIA		
7	86005710	57105	4	NUT, 1/4-20 HEX W/STAR WASHER		
8	86273740	70010	2	SCR, 1/4-20 X 1.50 HHCS		
9	86008920	80889	2	BOOT, RUBBER TERM. ISOLATOR		
10	86257490	76155	2	TERMINAL MOUNT		
11	86006840	70390	2	SCR, 1/4-20 X 1 FHCS PLTD		
12	86010630	87013	2	WASHER, 1/4 ID X 5/8 OD SS		
13	86273340	00-000289	4	SCR, 8-32 X 3/8 SHCS SS		
14	86001740	140816	1	BRAKE, 36VDC W/CONNECTOR		
15	86264930	27050	1	CABLE TIE, 3.5" UL/CSA		
16	86320870	-	1	SWITCH, 36V BRAKE		

WHEEL-FRONT DRIVE, GEAR

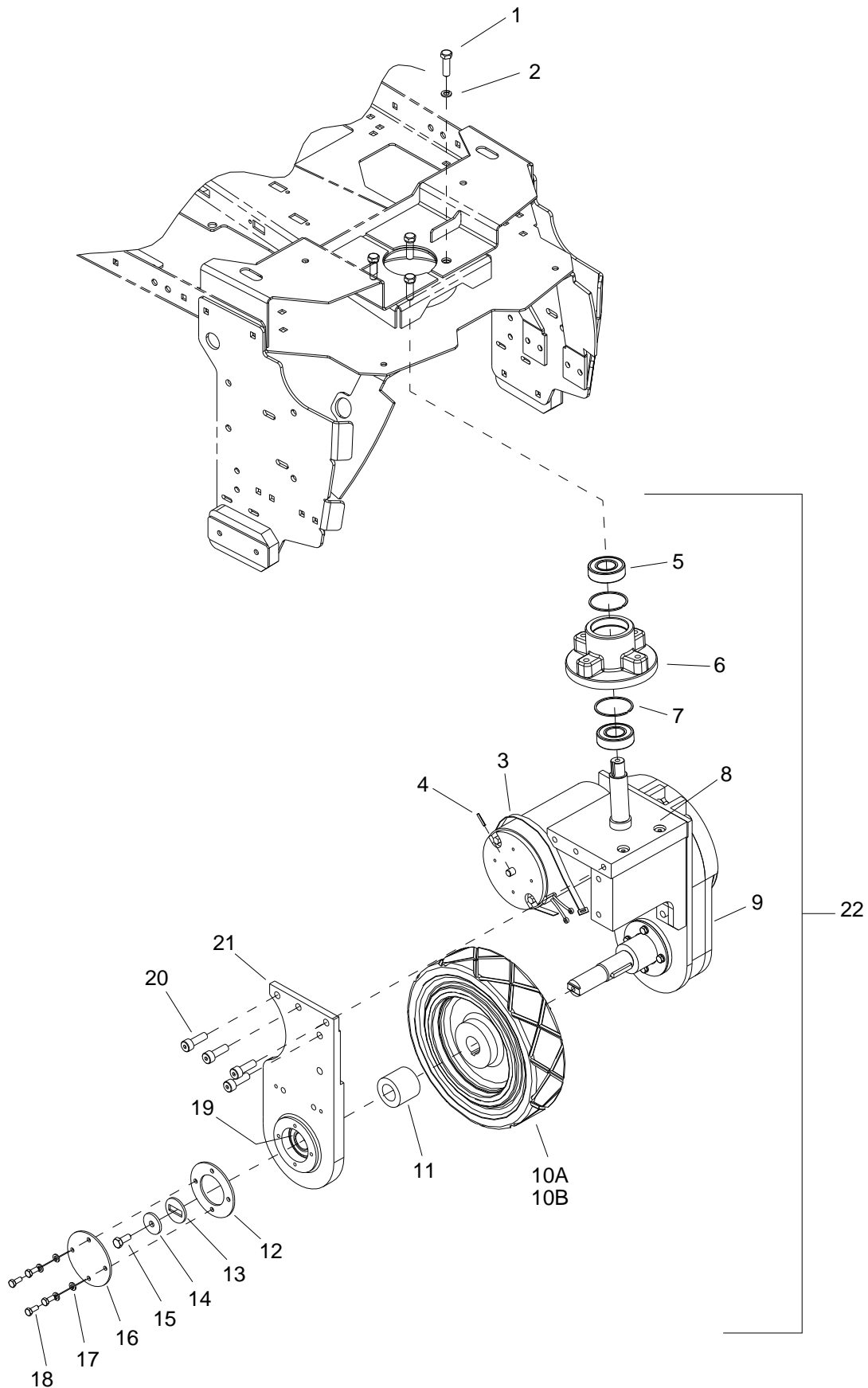

WHEEL-FRONT DRIVE, GEAR

REF	PART NO.	PRV NO.	QTY	DESCRIPTION	SERIAL NO. FROM	NOTES:
1	86275190	70377	4	SCR, 3/8-16 X 1.25 HHCS SS		
2	86010790	87163	4	WASHER, 3/8 SPLIT LOCK PLTD		
3	86002830	27196	1	CABLE TIE, .375 X 24.7		
4	86006170	66031	1	PIN, ROLL 1/8" X 3/4"L		
5	86223980	09134	3	SEALED BALL BRNG, 25MM X 52MM		
6	86219420	41510	1	HUB STEERING		
7	86223480	67450	2	RING, 52MM INTERNAL SNAP		
8	86224020	730233	1	SHAFT ASM, DRIVE PIVOT		
9	86317190	-	1	DRIVE MOTOR ASSEMBLY HELICAL		
10A	86011120	89262	1	WHEEL, 10 X 2, 5 X 1.06 W/KEYWAY		
10B	86259920	89273	1	WHEEL, 10 X 2. 5 W/KEYWAY, GRY		OPTION
11	86224440	730387	1	SPACER, 25.51 ID X 45 OD X 39.1 L		
12	86222720	620037	1	PLATE, BEARING RETAINER		
13	86225810	87506	1	WASHER, ANTI-ROTATION		
14	86279710	87245	1	WASHER, M8 (2THK X 26 OD)		
15	86136640	70262	1	SCR, M8-1.25 X 20 HHMS PLTD		
16	86222770	620042	1	PLATE, BEARING COVER		
17	86279690	87243	4	WASHER, M6 SPLIT LOCK BLK		
18	86277340	70830	4	SCR, M6 X 15 HHCS BLK		
19	86223980	09134	3	SEALED BALL BRNG, .25MM X 52MM		
20	86318830	-	10	SCR, M10 X 30 SHCS		
21	86222760	620041	1	PLATE, DRIVE YOKE RH		
22	86317200	-	1	GEAR BOX DRIVE UNIT HELICAL		WHEEL NOT INCLUDED
-	86216210	53820	-	BRUSH SET MOTOR, 53810 86005510		

WHEEL-REAR

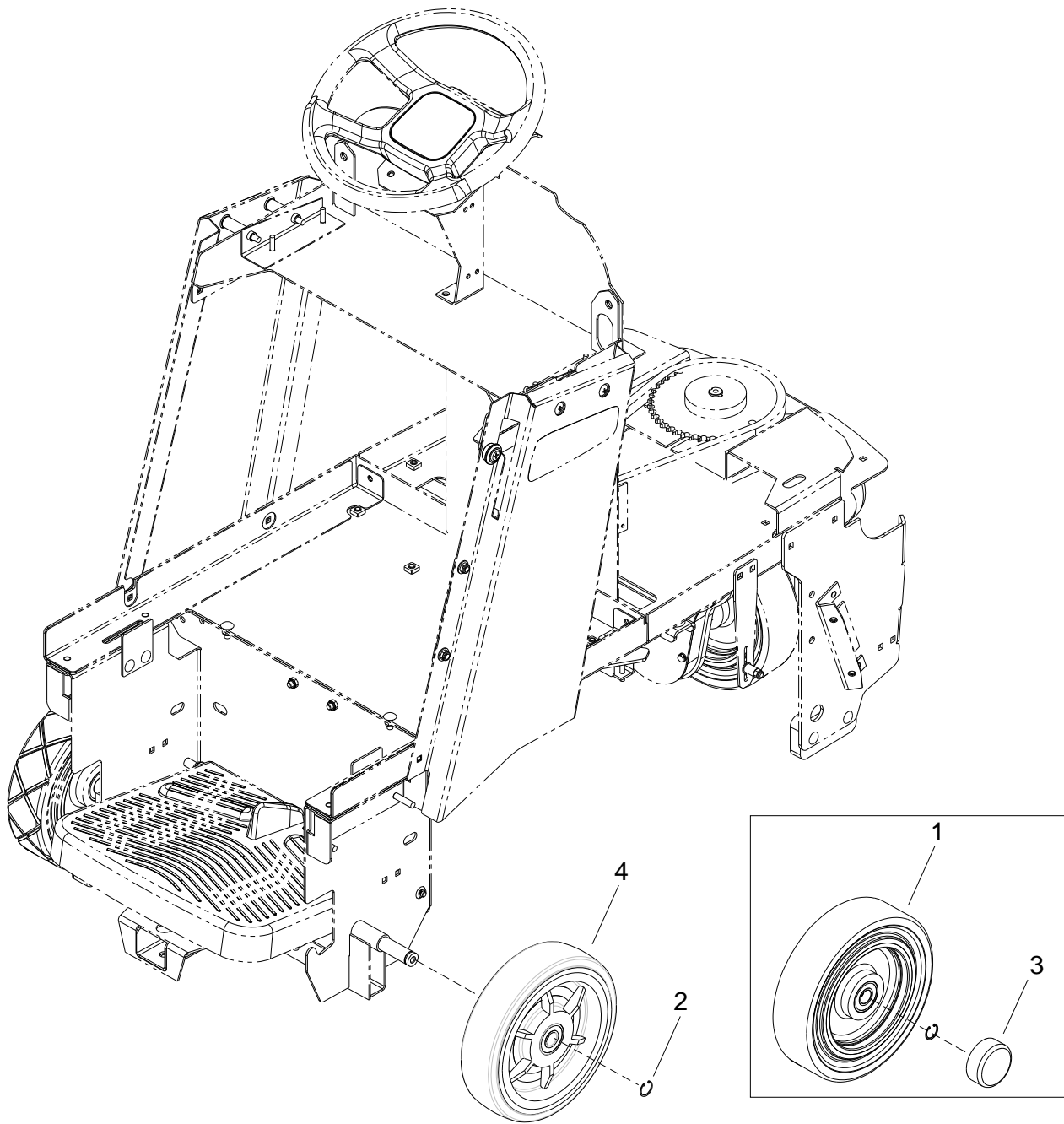

WHEEL-REAR

REF	PART NO.	PRV NO.	QTY	DESCRIPTION	SERIAL NO. FROM	NOTES:
1	86259950	89276	2	WHEEL, 10X2.5 W/BRNGS, GRY, NT		
2	86008710	80623	2	RING, 3/4" EXT SNAP H-D		
3	86232130	17309	2	CAP, 2.75 ID X 1.0 L BLK VINYL		
4	86322590	-	2	WHEEL, 10X2.5 W/BRNGS, GRY, NT	*(2)	

*SEE SERIAL NUMBER PAGE

** CALL MANUFACTURER FOR SERIAL NUMBER

WIRING-BATTERIES

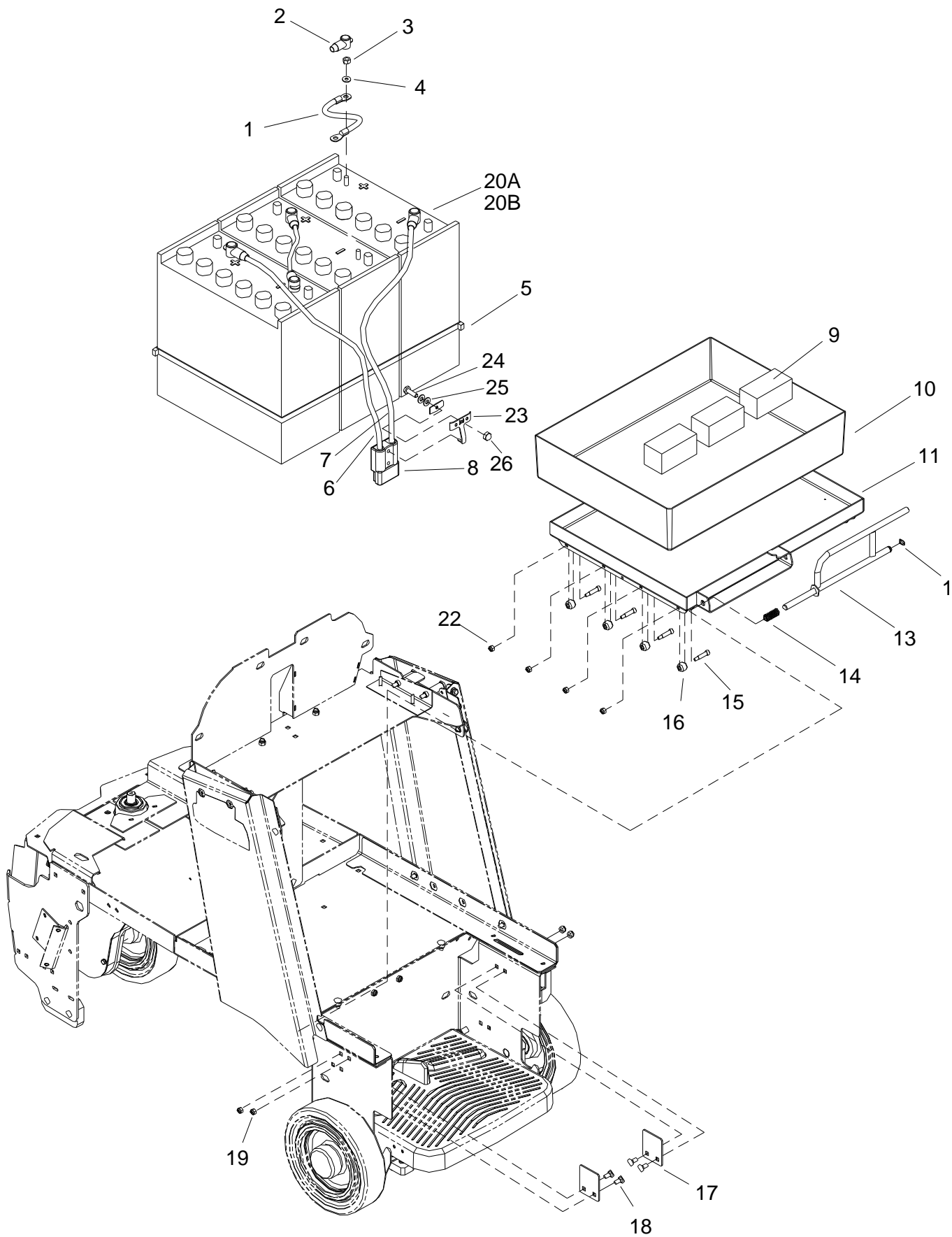

WIRING-BATTERIES

REF	PART NO.	PRV NO.	QTY	DESCRIPTION	SERIAL NO. FROM	NOTES:
1A	86260200	80872	2	WIRE, 4X14.5BK 5/16RINGX5/16RING		
1B	86002510	23125	2	WIRE, 4X15 BCLAMPXBCLAMP		
2	86008920	80889	6	BOOT, RUBBER TERM. ISOLATOR		
3	86271910	57295	6	NUT, 5/16-18 FLEXLOCK		
4	86010670	87029	6	WASHER, 5/16 FLAT SS		
5	86264960	27915	2	CABLE TIE, .375 X 43"		
6A	86260610	880836	1	WIRE, 4X25RD CTERM X 3/8RING		
6B	86002570	23190	1	WIRE, 4X27 RD BCLAMP X CTERM		
7A	86260230	80876	1	WIRE, 4X30 BK CTERM X 3/8RING		
7B	86002580	23191	1	WIRE, 4X27 BK BCLAMP X CTERM		
8	86008760	80682	1	CONN, 175 DCA GRY W/O TERMS		
9	86229700	08071	3	BLOCK, 3.0 X 1.5 X 1.5		
10	86008300	78242	1	TRAY, BATTERY LINEAR		
11	86008410	78568	1	TRAY, BATTERY		
12	86272810	67132	1	RING, 1/2 EXT. SNAP H-D		
13	86092910	51396	1	LATCH ROD, BATTERY TRAY		
14	86254990	730313	1	SPRING, COMP, 63ODX3.5LX.074W		
15	86278150	70117	8	SHOULDER BOLT, 5/16 OD X 1.0 L		
16	86259910	89265	8	WHEEL, BATTERY TRAY		
17	86088790	78571	2	TRAY, STANDARD STOP		
18	86276070	70593	4	SCR, 5/16-18 X 3/4 CARRIAGE SS		
19	86270830	57023	4	NUT, 5/16-18 HEX NYLOCK SS		
20A	86228410	10023	3	BATTERY, 12V, 205AH		
20B	86283410	10030	3	BATTERY, 12V, 225AH		
21	86284090	02456	1	CHARGER, 36V, 20A, 115V, C175		NOT SHOWN
22	86005810	57245	8	NUT, 1/4-20 HEX NYLOCK, SS		
23	86233360	28038	1	CLAMP, CABLE KIT SY945		
24	86273980	70066	1	SCREW, 10-32 X 3/4 PPHMS SS		
25	86010650	87018	1	WASHER, #10 X 9/16 OD		
26	86270890	57034	1	NUT, ACORN 10-32		

WIRING-COMPONENTS

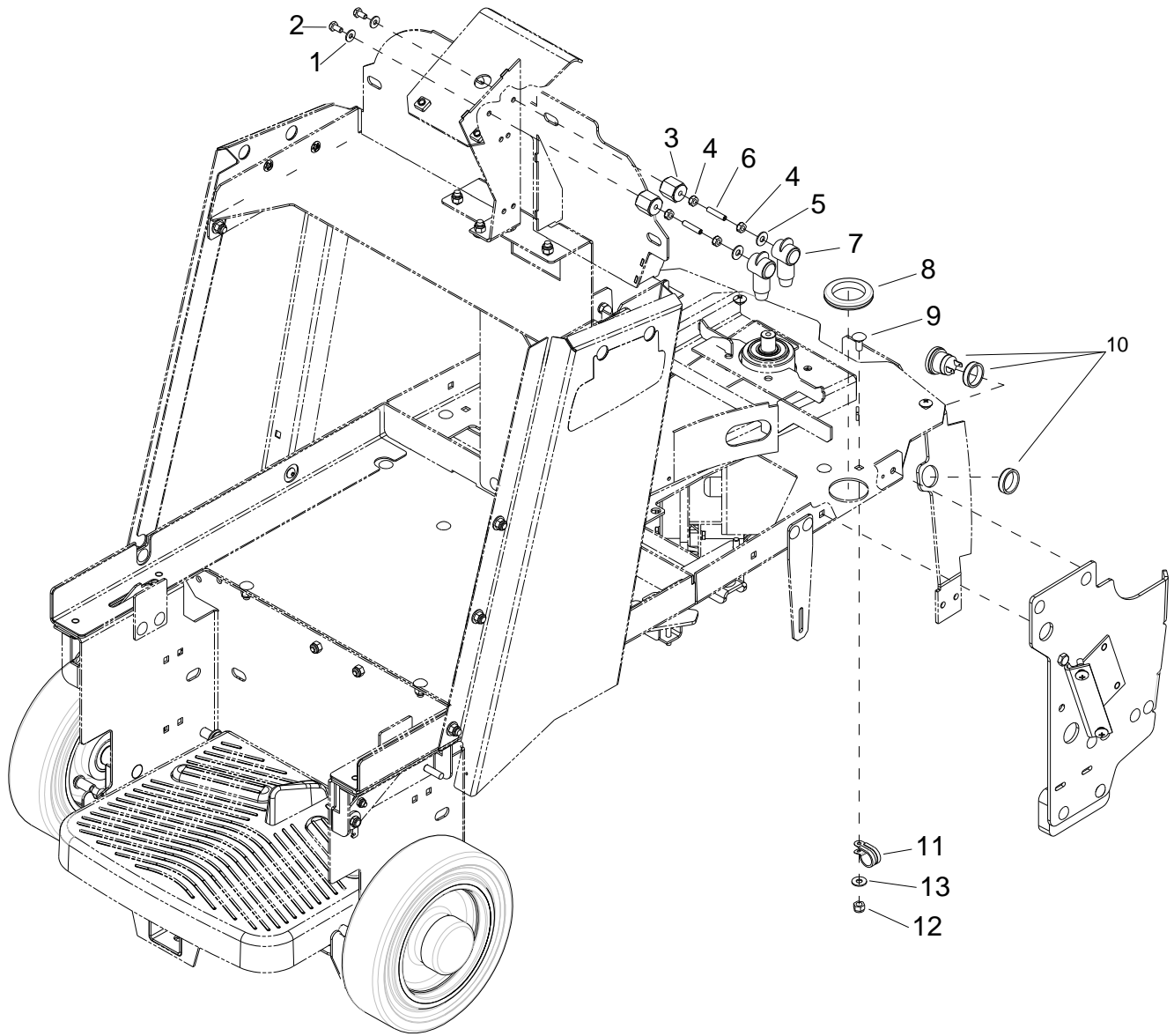

WIRING-COMPONENTS

REF	PART NO.	PRV NO.	QTY	DESCRIPTION	SERIAL NO. FROM	NOTES:
1	86273830	70020	2	SCR, 1/4-20 X 1/2 HHCS SS		
2	86010780	87162	2	WASHER, 1/4 SPLIT LOCK PLTD		
3	86255910	73659	2	STANDOFF, 1/4-20 X 1.0 HEX INS		
4	86005710	57105	2	NUT, 1/4-20 HEX W/STAR WASHER		
5	86006850	70393	2	SET SCR, 1/4-20 X 1.25L		
6	86005710	57105	2	NUT, 1/4-20 HEX W/STAR WASHER		
7	86010630	87013	3	WASHER, 1/4 ID X 5/8 OD SS		
8	86008920	80889	2	BOOT, RUBBER TERM. ISOLATOR		
9	86238500	81427	2	GROMMET, 1.703 ID X 2.5 OD X .125 GRV		
10	86276070	70593	1	SCR, 5/16-18 X 3/4 CARRIAGE SS		
11	86233410	81270	1	CLAMP, 3/4 DIA CUSHION .406 DIA		
12	86270830	57023	1	NUT, 5/16-18 HEX NYLOCK SS		
13	86239720	41520	1	HORN, 108DB MINIATURE PIEZO		

WIRING-CONTROL PANEL

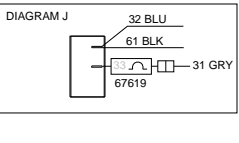
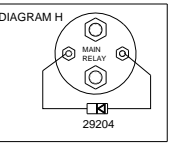
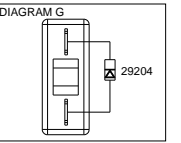
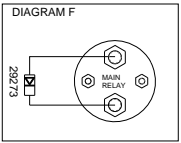
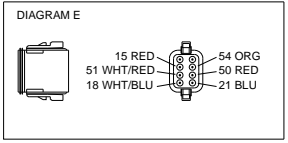
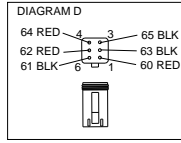
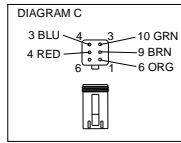
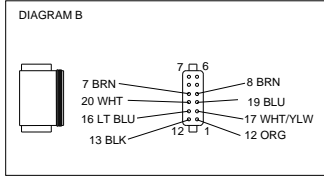
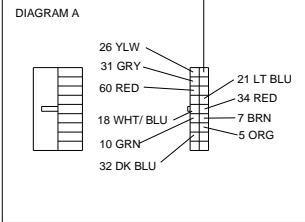
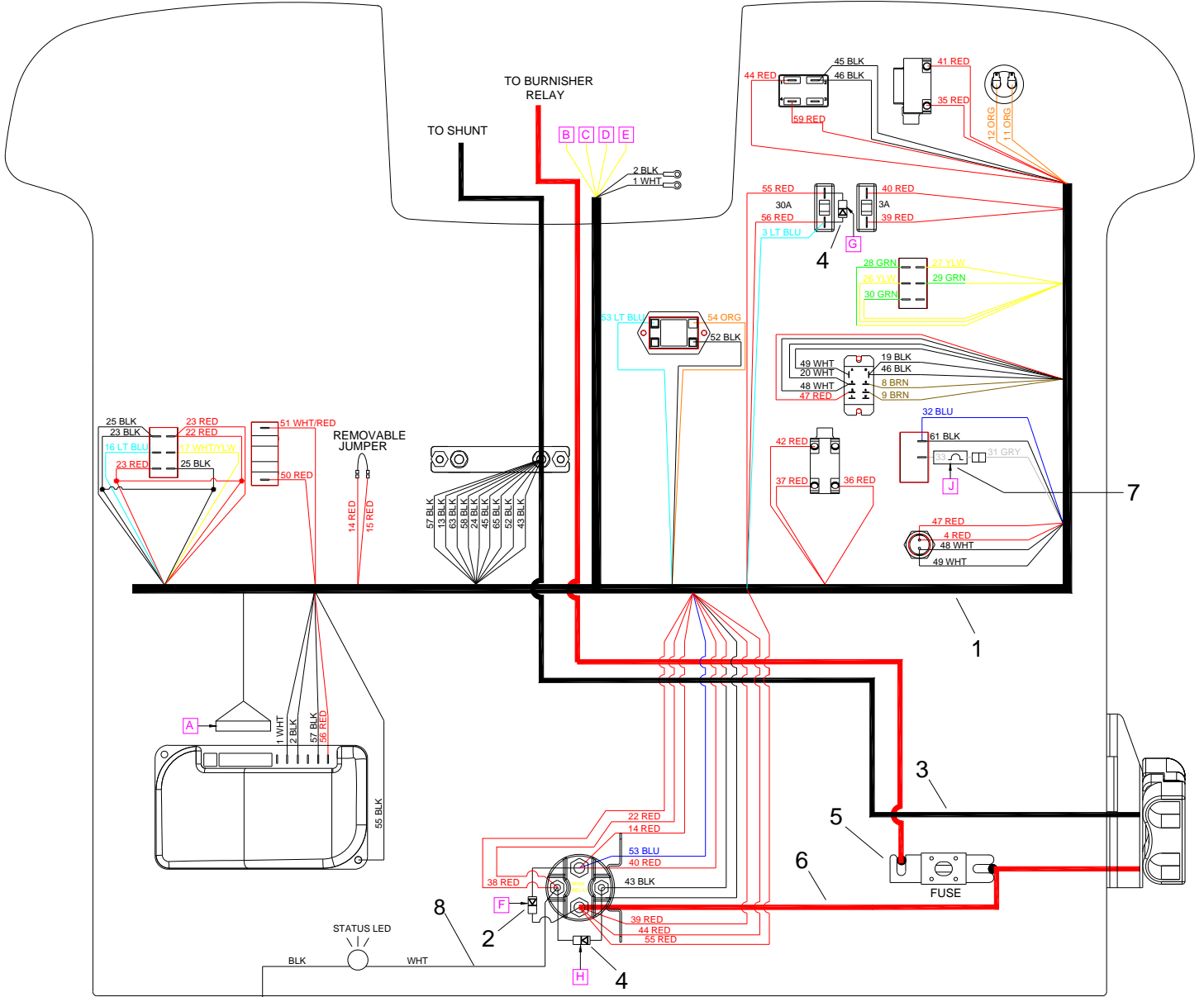

WIRING-CONTROL PANEL

REF	PART NO.	PRV NO.	QTY	DESCRIPTION	SERIAL NO. FROM	NOTES:
1	86239180	41537	1	HARNESS, CONTROL PANEL BRSHR		
2	86261250	29273	1	DIODE ASM, FAST RECOVERY		
3	86010860	880353	1	WIRE, 4X20 BK CTERM X 5/16 RING		
4	86261210	29204	2	DIODE ASM, 76008 X 76008		
5	86237000	80688	1	FUSE, 80 AMP		
6	86260560	880428	1	WIRE, 4X10RD 5/16RING X 5/16RING		
7	86251490	67619	1	RESISTOR ASM, 1/2 WATT 33 OHM		
8	86311210	-	1	LIGHT ASM, INDICATOR, CODE		

WIRING-DRIVE MOTOR

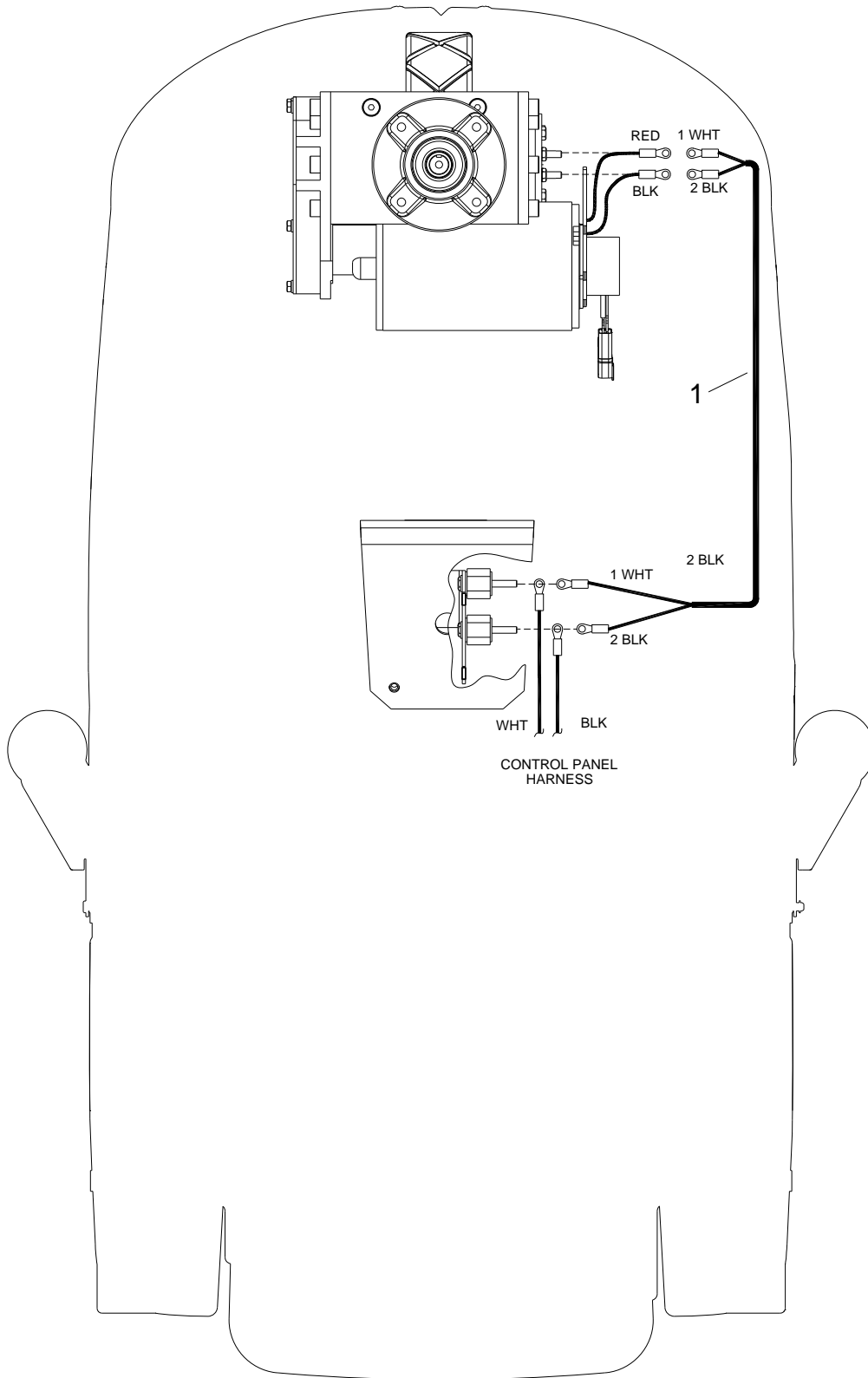

WIRING-DRIVE MOTOR

120 REF	PART NO.	PRV NO.	QTY	DESCRIPTION	SERIAL NO. FROM	NOTES:
1	86239120	41522	1	HARNESS, CHARIOT PROPEL		

WIRING-MAIN HARNESS

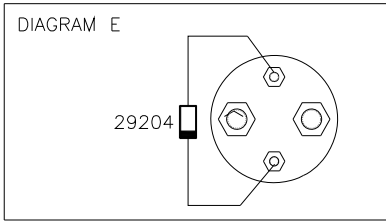
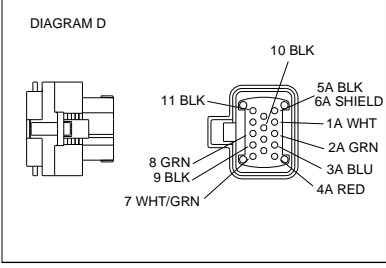
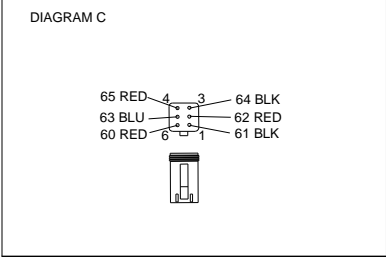
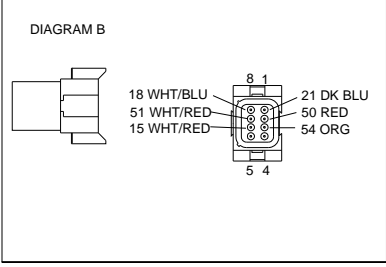
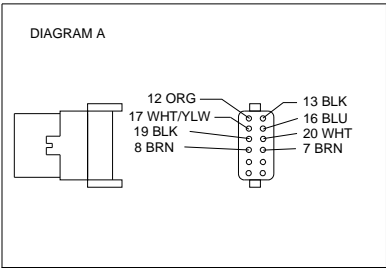
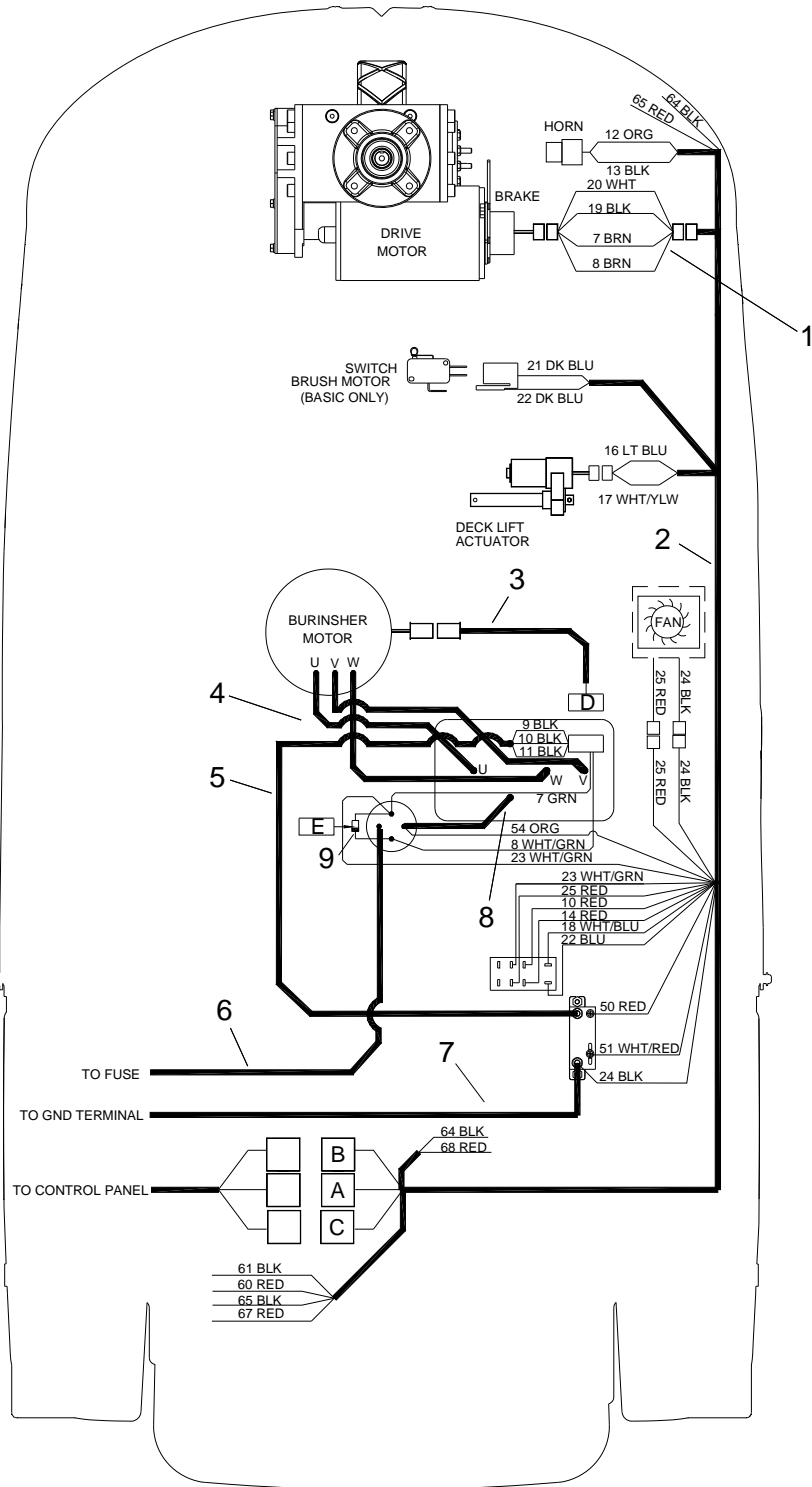

SHOWS OPTIONAL EQUIPMENT

WIRING-MAIN HARNESS

REF	PART NO.	PRV NO.	QTY	DESCRIPTION	SERIAL NO. FROM	NOTES:
1	86239170	41528	1	HARNESS, BRAKE		
2	86239190	41538	1	HARNESS, MAIN BRSHR		
3	86239520	880446	1	HARNESS, HALL SENSOR		
4	86260220	80875	3	WIRE4X30BK 5/16RINGX5/16RING		
5	86009000	81131	1	WIRE4X9.5BK 5/16RINGX5/16RING		
6	86260600	880445	1	WIRE, 4X36 RD 5/16 RING		
7	86010860	880353	1	WIRE, 4X20 BK CTERM X 5/16 RING		
8	86260580	880443	1	WIRE, 4X12 RD 5/16 RING		
9	86261210	29204	1	DIODE ASM, 76008 X 76008		

WIRING-PEDAL PLATFORM-From Serial Number (4*)

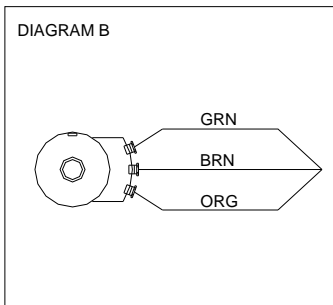
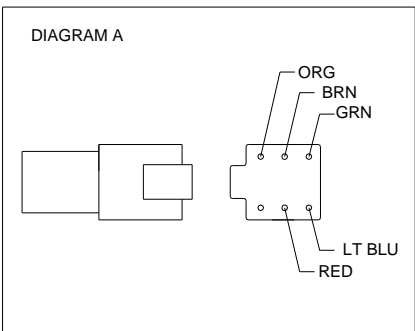
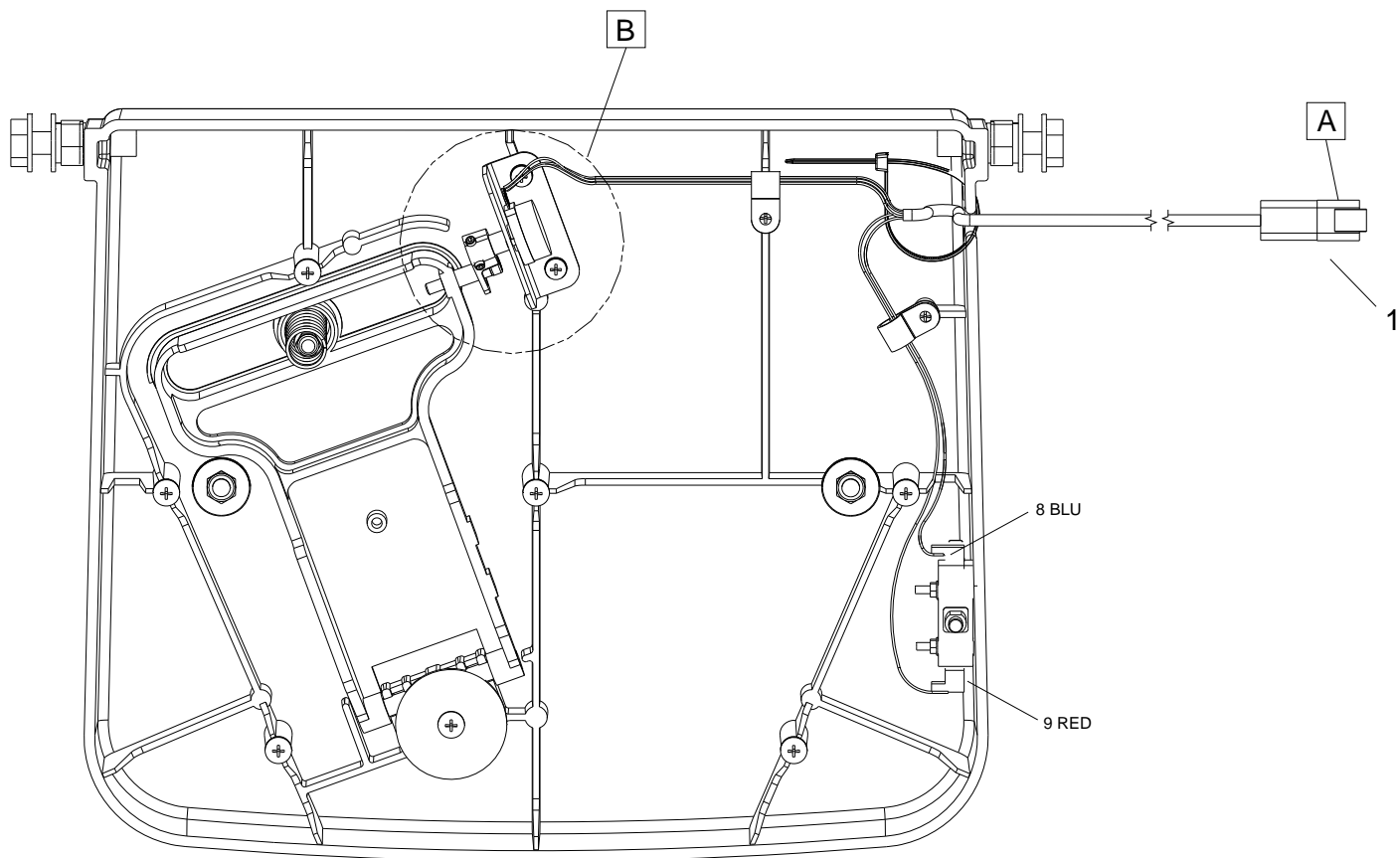

WIRING-PEDAL PLATFORM-From Serial Number (4*)

REF	PART NO.	PRV NO.	QTY	DESCRIPTION	SERIAL NO. FROM	NOTES:
1	86315100	-	1	HARNESS, PEDAL		

***SEE SERIAL NUMBER PAGE.**

WIRING-PEDAL PLATFORM-To Serial Number (4*)

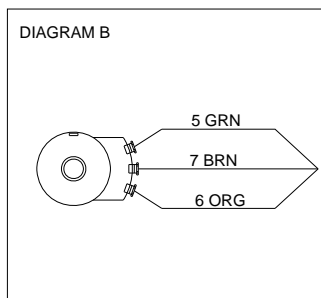
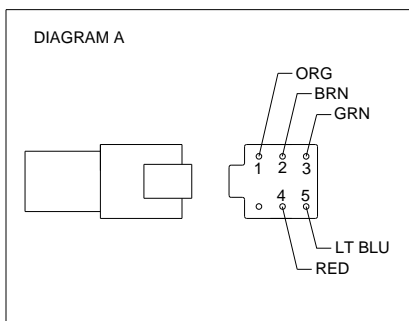
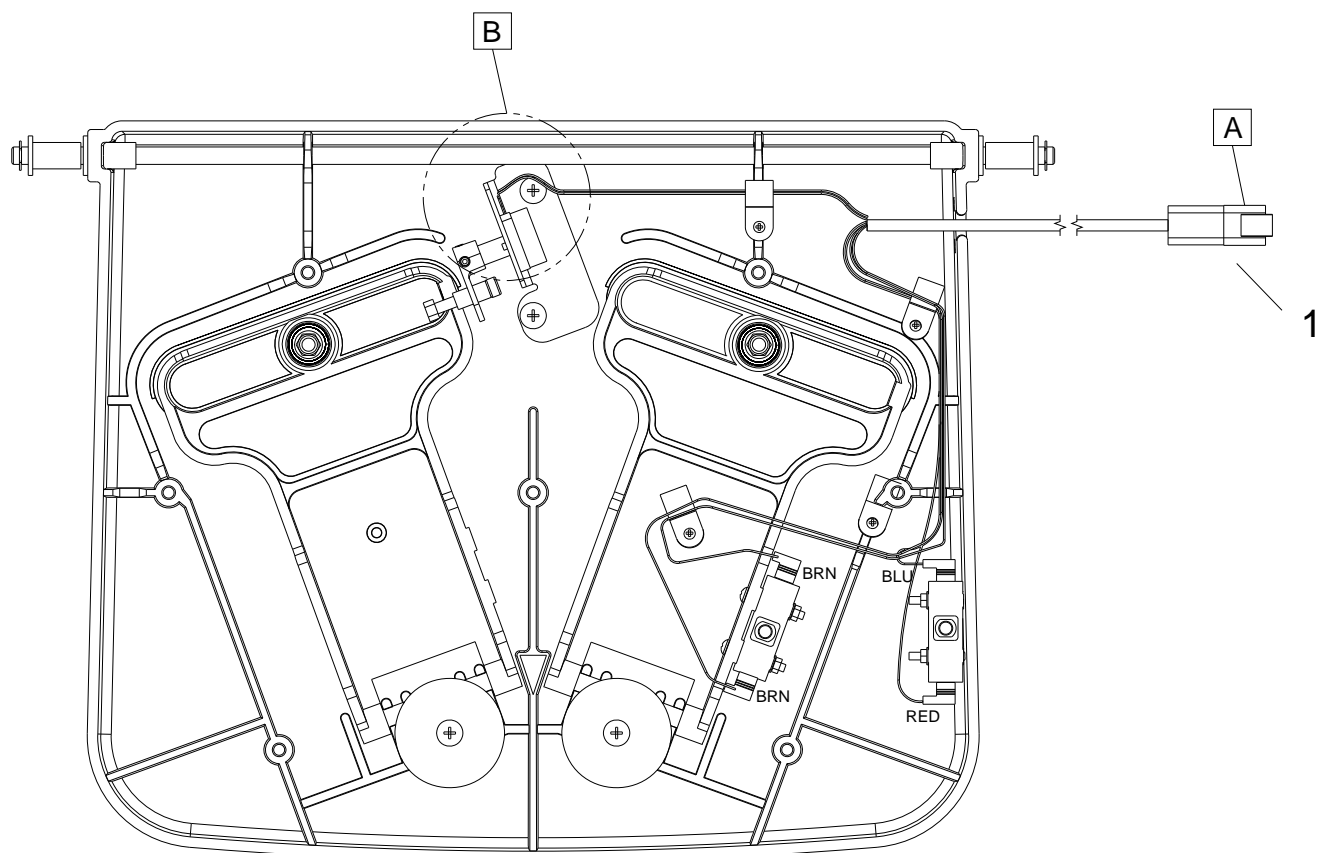

WIRING-PEDAL PLATFORM-To Serial Number (4*)

REF	PART NO.	PRV NO.	QTY	DESCRIPTION	SERIAL NO. FROM	NOTES:
1	86218810	23717	1	HARNESS, TWISTER PEDAL		

***SEE SERIAL NUMBER PAGE.**

WIRING DIAGRAM

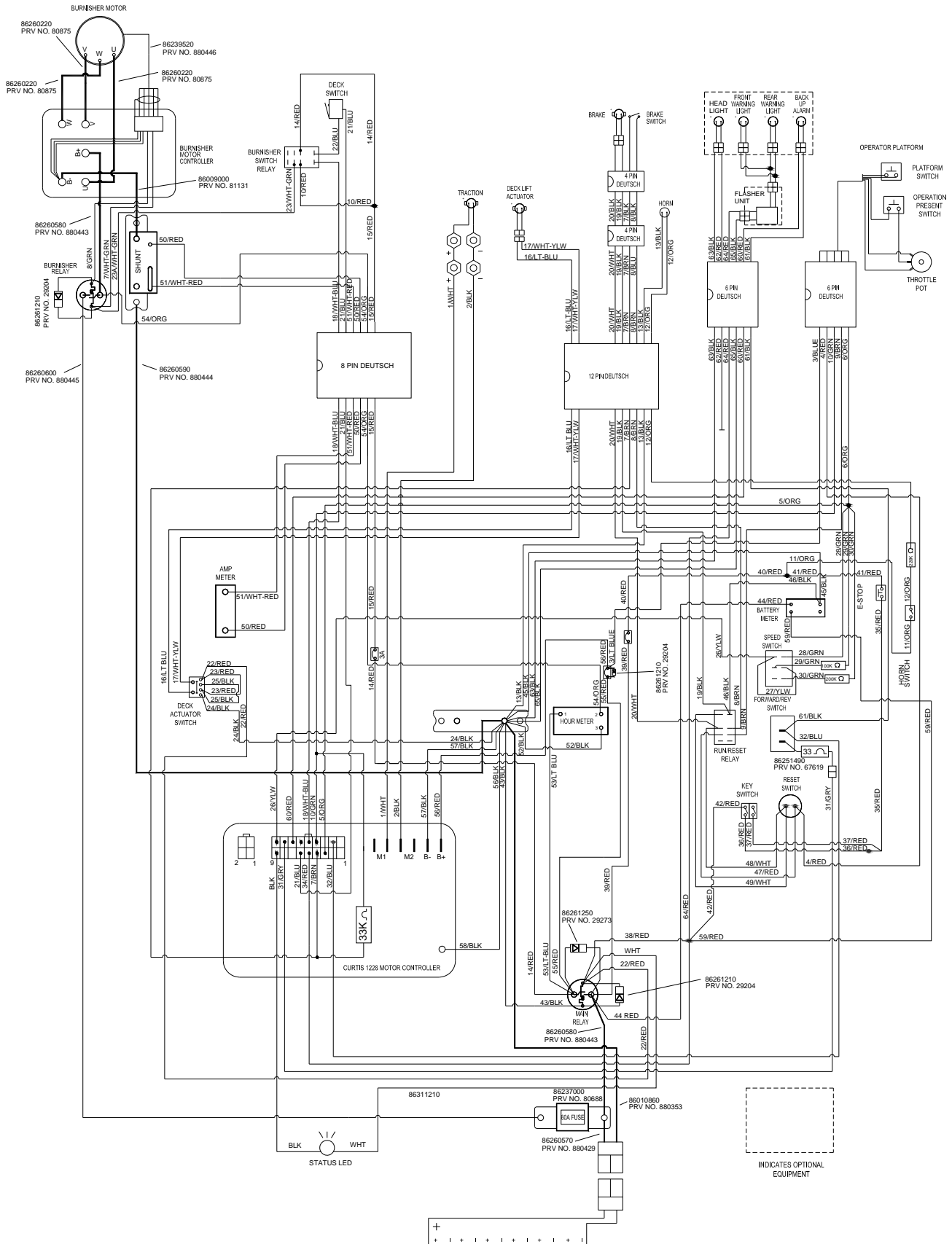

SUGGESTED SPARE PARTS

PART NO.	PRV NO.	DESCRIPTION	SERIAL NO. FROM	NOTES:
86284870	2003SM	SM FILTER BAG PACKS 10/PKG		
86001910	14606	BREAKER, 30A 50VDC CIRCUIT		
86002000	14717	BREAKER, 3 AMP		
86002010	14942	BOOT, 3/8 CIRCUIT BREAKER		
86004870	48077	KNOB, 3.50 OD X 3/8-16		
86248280	64110	PAD DRIVER ASSEMBLY 20", .88 BORE		
86251410	67506	RELAY, 15A 36V MINI		
86007140	72130	SWITCH, SPST 2-POSITION ROCKER		
86007170	72159	SWITCH KEY TWO POSITION		
86007190	72161	SWITCH KEY DPST		
86007240	72190	SWITCH, SEALED PB ROUND		
86237000	80688	FUSE, 80 AMP		
86001740	140816	BRAKE, 36 VDC W/CONNECTOR		
86002730	270085	CHAIN, ISO 08B 12.7 MM PITCH		
86216230	730074	BRUSH, STRIP (PACKAGE OF 6)		
86026450	730352	SHROUD, 20" BURNISHER		
86064370	66829	PAN, BURNISHER PAD		PAD INSTALLATION TOOL
86226930	51419	LOCK, PAD DRIVER YELLOW		

BACK-UP ALARM - OPTION

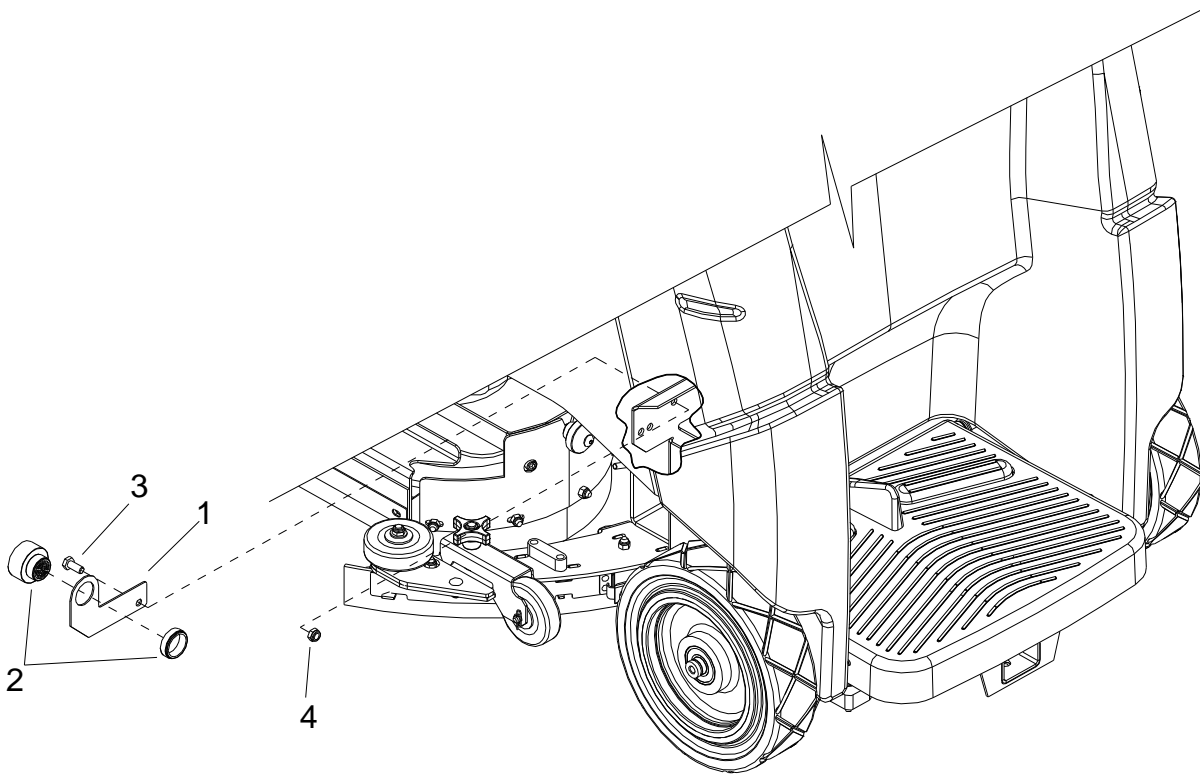

BACK-UP ALARM - OPTION

REF	PART NO.	PRV NO.	QTY	DESCRIPTION	SERIAL NO. FROM	NOTES:
1	86071140	140817	1	BRKT, BACK UP ALARM		
2	86231500	80882	1	BUZZER, PIEZO 6-28VCD		
3	86276780	70728	1	SCR, 5/16-18 X 3/4 HHCS SS		
4	86271840	57285	1	NUT, 5/16-18 HEX NYLOCK THN SS		

BATTERY CART - OPTION

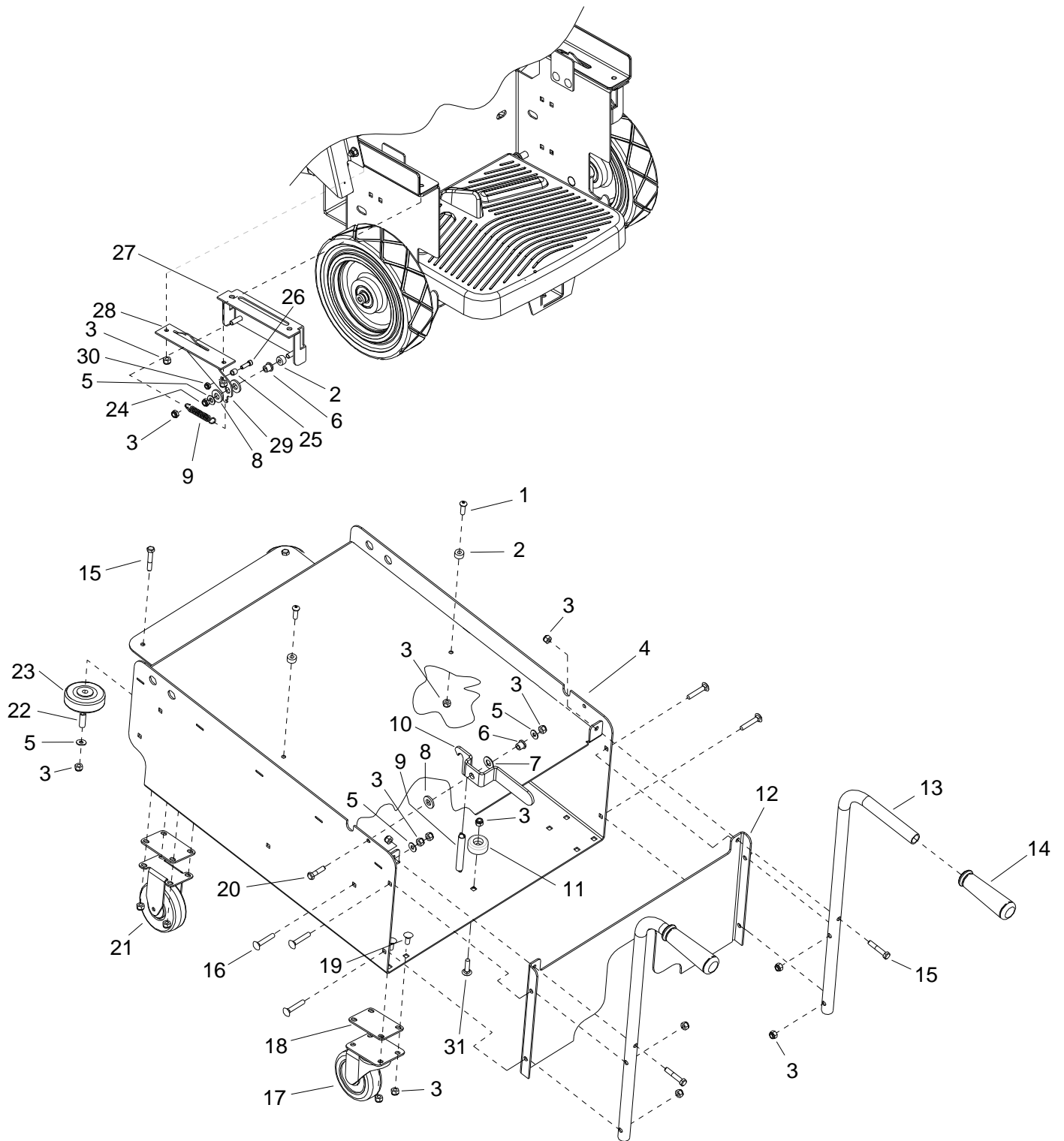

BATTERY CART - OPTION

REF	PART NO.	PRV NO.	QTY	DESCRIPTION	SERIAL NO. FROM	NOTES:
1	86006930	70514	2	SCR, 5/16-18 X 1.00 BSHCS SS		
2	86254290	730338	4	SPACER, 10D X .343ID, .5 LG		
3	86270830	57023	33	NUT, 5/16-18 HEX NYLOCK SS		
4	86077010	41517	1	HOUSING, BATTERY CART		
5	86010670	87029	7	WASHER, 5/16 FLAT SS		
6	86228840	09124	3	BEARING, FLANGED .314D X .502OD		
7	86259410	87206	1	WASHER, THRUST, .51 ID X 1 OD X .063		
8	86259400	730331	4	WASHER, THRUST .51 ID X 1 OD		
9	86254890	730018	3	SPRING, EXT, .50D X 4.0L		
10	86068490	140019	1	BRKT, TRAY CATCH		
11	86231090	80809	1	BUMPER, RUBBER 5/16" ID X 1.50		
12	86083120	66442	1	PLATE, BATTERY CART BACK		
13	86076600	38318	2	HANDLE, BATTERY CART		
14	86004070	36196	2	GRIP, POLISHER HANDLE		
15	86276790	70732	4	SCR, 5/16-18 X 1.75 HHCS SS		
16	86276690	70715	7	SCR, 5/16-18 X 1.75 CARR SS		
17	86199430	040-03	2	CASTER SWIVEL 4" 250# CPCTY		
18	86078890	620020	8	PLATE, CASTER SPACER		
19	86277130	70795	16	SCR, 5/16-18 X 1.00 CARRIAGE SS		
20	86007020	70673	1	SP SCR, 5/16-18 X 1.25 HHCS SS NP		
21	86232590	18032	2	CASTER, 4" HARD RUBBER RIGID		
22	86001350	140390	2	BUSHING, SPANNER .435 X 1.10		
23	86011020	89202	2	WHEEL, 3" DIA CUSHION RUBBER		
24	86271840	57285	2	NUT, 5/16-18 HEX NYLOCK THIN SS		
25	86008130	73958	2	SPACER, 3/8OD X .62W X .312L, AL		
26	86274730	70265	2	SCR, 1/4-20 X 3/4 SHCS PLTD		
27	86070790	140737	2	BRKT, BATTERY LOCK MOUNT		
28	86087340	730339	2	SPACER, LATCH GUIDE		
29	86070800	140738	2	BRKT, BATTERY TRAY LOCK		
30	86271870	57290	2	NUT, 1/4-20 HEX NYLOCK THIN SS		
31	86276070	70593	1	SCR, 5/16-18 X 3/4 CARRIAGE SS		

BATTERY CART - OPTION

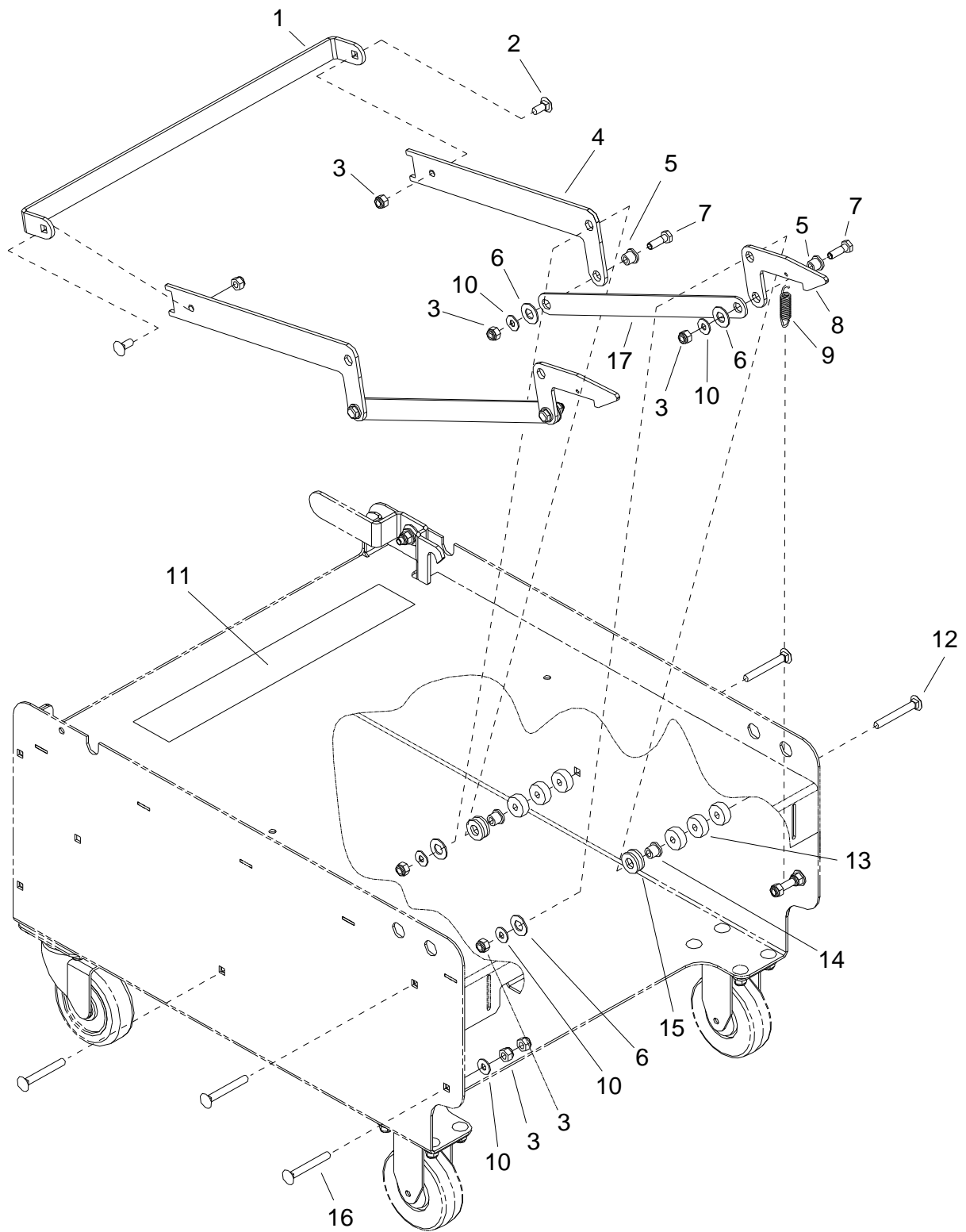

BATTERY CART - OPTION

REF	PART NO.	PRV NO.	QTY	DESCRIPTION	SERIAL NO. FROM	NOTES:
1	86078330	66478	1	PEDAL, BATTERY CART		
2	86276070	70593	2	SCR, 5/16-18 X 3/4 CARRIAGE SS		
3	86270830	57023	12	NUT, 5/16-18 HEX NYLOCK SS		
4	86087800	730307	2	STIFFENER, PEDAL, BATTERY CART		
5	86228840	09124	4	BEARING, FLANGED .314ID X .502OD		
6	86259410	87206	6	WASHER, THRUST .51 ID X 1 OD X .063		
7	86006560	70083	4	SCR, 5/16-18 X 1 HHCS SS		
8	86077140	51404	2	LATCH, BATTERY CART		
9	86226830	73268	2	SPRING, EXT .68D X 3.00L X .098W		
10	86010670	87029	10	WASHER, 5/16 FLAT SS		
11	86244280	500934	1	LABEL, BATTERY CAR OPERATION		
12	86276060	70590	4	SCR, 5/16-18 X 2.5 CARR GR5		
13	86254280	730331	12	SPACER, 1.00 ODX .32ID X .375		
14	86231150	09151	4	BUSHING FLANGE, .314 X .502 OD		
15	86259400	87205	8	WASHER, THRUST .51 ID X 1 OD		
16	86276690	70715	16	SCR, 5/16-18 X 1.75 CARR SS		
17	86077530	51403	2	LINKAGE, LATCH, BATT CART		

SEAT - OPTION

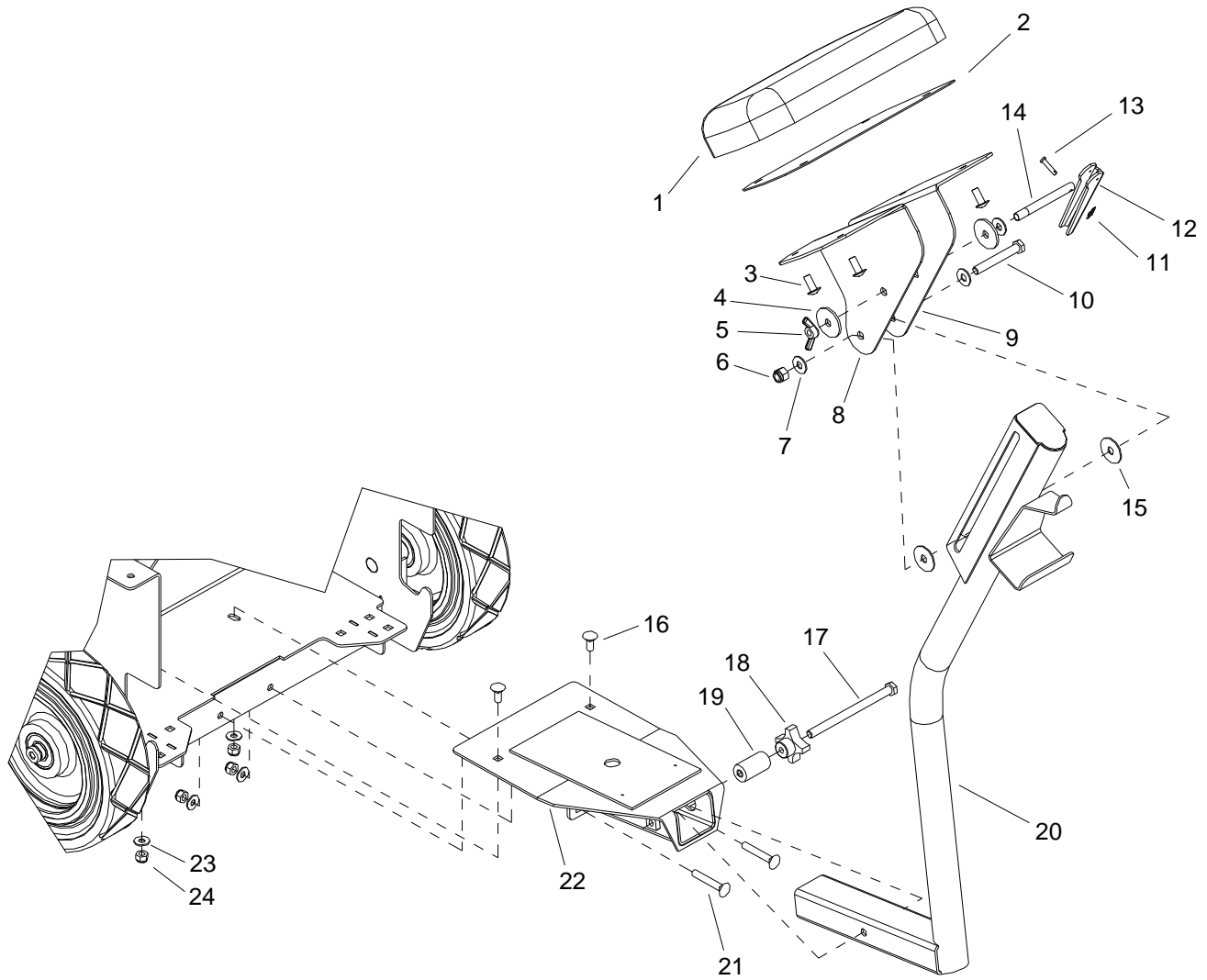

SEAT - OPTION

REF	PART NO.	PRV NO.	QTY	DESCRIPTION	SERIAL NO. FROM	NOTES:
1	86248390	730324	1	PAD, REAR REST		
2	86082640	629995	1	PLATE, SEAT COVER		
3	86276890	70752	4	SCR, 5/16-18 X 3/4 PTHMS SS		
4	86279460	87164	2	WASHER, 1/2 SPLIT LOCK		
5	86270710	01-000277	1	NUT, WING 3/8-16		
6	86271930	57297	1	NUT, 3/8-16 HEX NYLOCK SS		
7	86278910	87003	3	NUT, 3/8-16 HEX NYLOCK SS		
8	86070830	140742	1	BRKT, LEFT REAR SEAT		
9	86070840	140743	1	BRKT, RIGHT REAR SEAT		
10	86277710	730347	1	SCR, 3/8-16 X 2.75 HHCS SS		
11	86008650	80604	1	COTTER, 1/4" RING		
12	86246320	51142	1	LEVER, HANDLE LOCK		
13	86272300	66133	1	PIN, CLEVIS 3/16 X .88 PLTD		
14	86251860	66481	1	ROD, ARM HANDLE LOCK 4" LG		
15	86279620	87200	2	WASHER, .41D X 1.3OD NYLON		
16	86276070	70593	2	SCR, 5/16-18 X 3/4 CARRIAGE SS		
17	86277510	70857	1	SCR, 3/8-16 X 5.0 HHCS SS FT		
18	86009200	81535	1	KNOB, 3/8-16 4 PRONG ALUM		
19	86254300	730350	1	SPACER, SEAT LOCK		
20	86094000	05246	1	SEAT MOUNT POST		
21	86276710	70717	2	SCR, 5/16-18 X 2.0 CARRIAGE SS		
22	86093790	05247	1	RECEIVER ASSY, SEAT MOUNT		
23	86010670	87029	4	WASHER, 5/16 FLAT SS		
24	86270830	57023	4	NUT, 5/16-18 HEX NYLOCK SS		

WARNING LIGHTS - OPTION

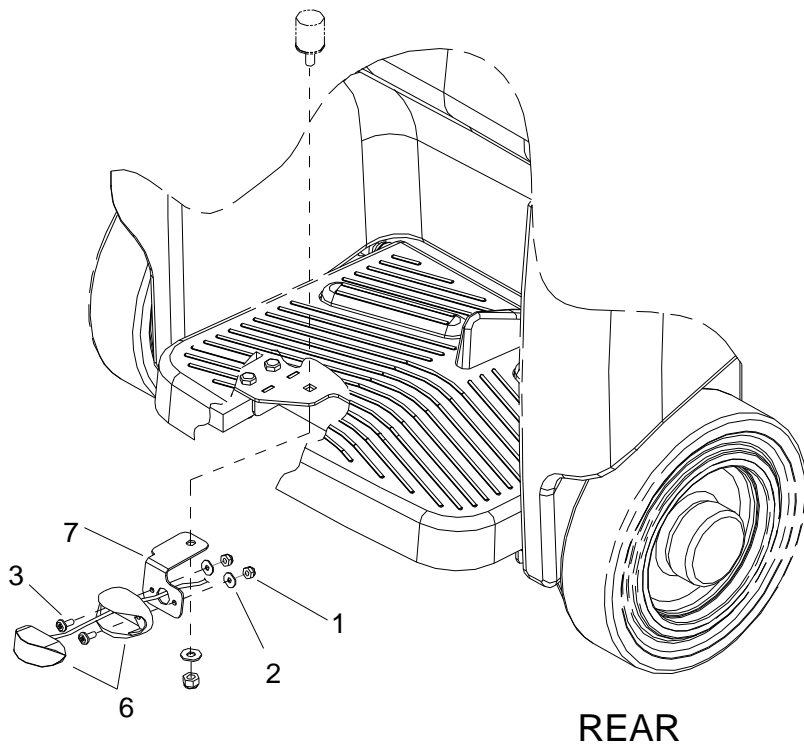
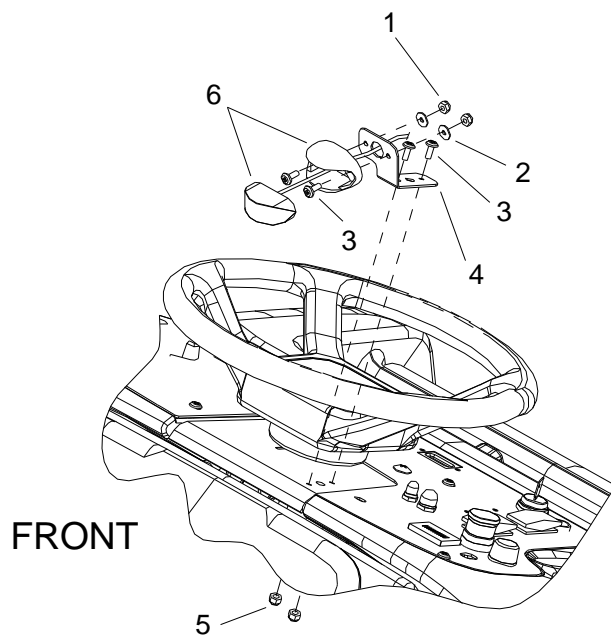

WARNING LIGHTS - OPTION

REF	PART NO.	PRV NO.	QTY	DESCRIPTION	SERIAL NO. FROM	NOTES:
1	86270990	57090	4	NUT, 10-32 HEX NYLOCK SS		
2	86010650	87018	4	WASHER, #10 X 6/16 OD		
3	86276820	70740	4	SCR, 10-32 X 1/2 PTHMS BLK		
4	86071490	140871	1	BRKT, UPPER WARNING LIGHT		
5	86270990	57090	2	NUT, 10-32 HEX NYLOCK SS		
6	86246200	51454	2	LED AMBER LIGHT, 12V		
7	86071500	140872	1	BRKT, LOWER WARNING LIGHT		



Manufacturers of Innovative Building Maintenance Equipment

Windsor Industries, Inc.
1351 West Stanford Avenue
Englewood, CO 80110 USA

Phone: 303.762.1800
FAX: 303.762.0817
<http://www.windsorind.com>

EC Declaration of Conformity

We herewith declare, Windsor Industries, Inc.
1351 W. Stanford Ave.
Englewood, CO 80110-5545 USA

that the following product complies with the appropriate essential health and safety requirements of the relevant EC Directives listed below, based on the relevant sections of the applicable EC standards and other normative documents.

Product: Chariot Burnisher 20 - Euro

Product Identification: Rated 36 VDC 95 A

Trademark:



Model/Type Ref.: CBE20

Product Description: This product is a battery powered, self-propelled, wet floor scrubber intended for commercial use.

Applicable EC Directives: EC Machinery Directive
(89/392/EEC & 91/368/EEC & 93/44/EEC & 93/68/EEC)
EC Low Voltage Directive
(73/23/EEC & 93/68/EEC)
EC Directive of Electromagnetic Compatibility
(89/336/EEC & 93/68/EEC)

Applicable Harmonized Standards: EN 60335-1: 1991
EN 60335-2-67: 1992
EN 60335-2-72: 1995
EN 55022: 1998-09
EN 55011: 1998-05
EN 61000-6-2: 1999
EN 61000-4-2: 1995
EN 61000-4-3: 1997

 7-5-05
Authorized Signature Date

Title of Signature: Vice President, Windsor Industries, Inc.



SERIAL NUMBERS

REF. NO.	MODEL: SERIAL #
1	CBE20:10020100000010, CB20: 10020080000369, CB20X: 100200900096
2	CBE20:10020100000011, CB20: 10020080000406, CBCD20: 10020160000002
3	CBE20:10020100000011, CB20: 10020080000437, CBCD20: 10020160000003
4	CBE20:10020100000017, CB20: 10020080000509, CBCD20: 10020160000008