

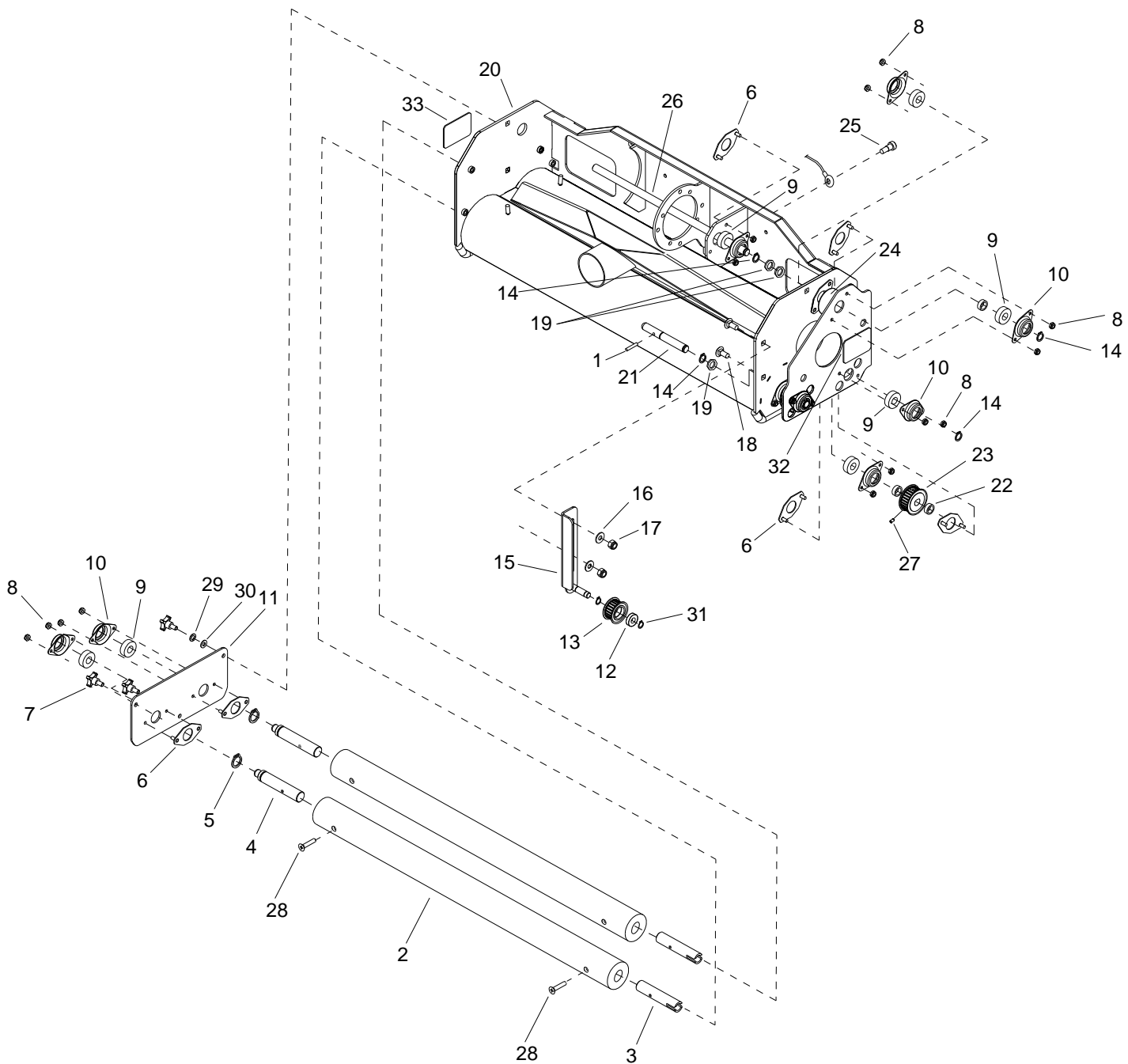

chariot[®]
PARTS

BRUSH DECK



BRUSH DECK

REF	PART NO.	PRV NO.	QTY	DESCRIPTION	SERIAL NO. FROM	NOTES:
1	86272350	66194	2	PIN, DOWEL GROOVE 3/16" X 3/4"L		
2	86230700	12536	2	BRUSH, 27.75 X 4.0 OD		
3	86227730	03130	2	AXLE, BRUSH DRIVE RECIEVER STUB		
4	86227720	03129	2	AXLE, BRUSH BEARING STUB		
5	86008710	80623	4	RING, 3/4" EXT SNAP H-D		
6	86079420	620113	9	PLATE, LOCK W/STUDS		
7	86200500	140-11	3	KNOB, RT/TANK	*(12)	WAS 70893
8	86271900	57294	18	NUT, 10-24 HEX NYLOCK THIN SS		
9	86319050	-	9	BEARING, SHIELDED 1.125 OD X .500 ID	*(13)	WAS 09019
10	86000920	09055	9	BEARING FLANGE		
11	86079430	620114	1	PLATE, BRUSH DOOR		
12	86229010	09162	2	BEARING, 22 X 10 X 6 SS		
13	86250740	64118	1	PULLEY, TIMING 5MM HTD 22T 15W		
14	86272810	67132	7	RING, 1/2 EXT. SNAP H-D		
15	86068460	78943	1	BRACKET, BELT TENSIONER		
16	86279630	87212	2	WASHER, .344 ID X .13 OD X .09 T PLT		
17	86270830	57023	2	NUT, 5/16-18 HEX NYLOCK SS		
18	86277130	70795	2	SCR, 5/16-18 X 1.0 CARRIAGE SS		
19	86279350	87140	8	WASHER, WAVE 1/2ID X 3/4D X .125		
20	86092260	29278	1	DECK, BRUSH VACUUM		
21	86323980	-	2	AXLE, BRUSH STUB	*(15)	WAS 86227710
22	86254330	730401	5	SPACER. .504 ID X .690 OD X .25 L		
23	86250750	64119	3	PULLEY, TIMING 5MM HTD 30T, 15W		
24	86229450	11050	1	BELT, TIMING, 5MM X 12MM 2-SIDED		
25	86278330	70641	1	SHOULDER BOLT, 3/8OD X 3/8L SS		
26	86227700	03127	1	AXLE, .50DIA X 14 W/FLATS, JACK		
27	86278100	70894	3	SET SCR, 10-32 X .5 SOC CUP PT SS		
28	86277650	70895	4	SCR, 1/4-20 X 1.25 PFHMS SS		
29	86010780	87162	3	WASHER, 1/4 SPLIT LOCK PLTD		
30	86010630	87013	3	WASHER, 1/4 ID X 5/8 OD SS		
31	86272830	67138	2	RING, 3/8 EXT SNAP		
32	86296990	-	1	LABEL, BELT ROUTING, IVAC	*(1)	
33	86244500	501107	1	LABEL, BRUSH ORIENTATION	*(1)	

* SEE SERIAL NUMBER PAGE

**CALL MANUFACTURER FOR SERIAL NUMBER

BRUSH DECK LINKAGE

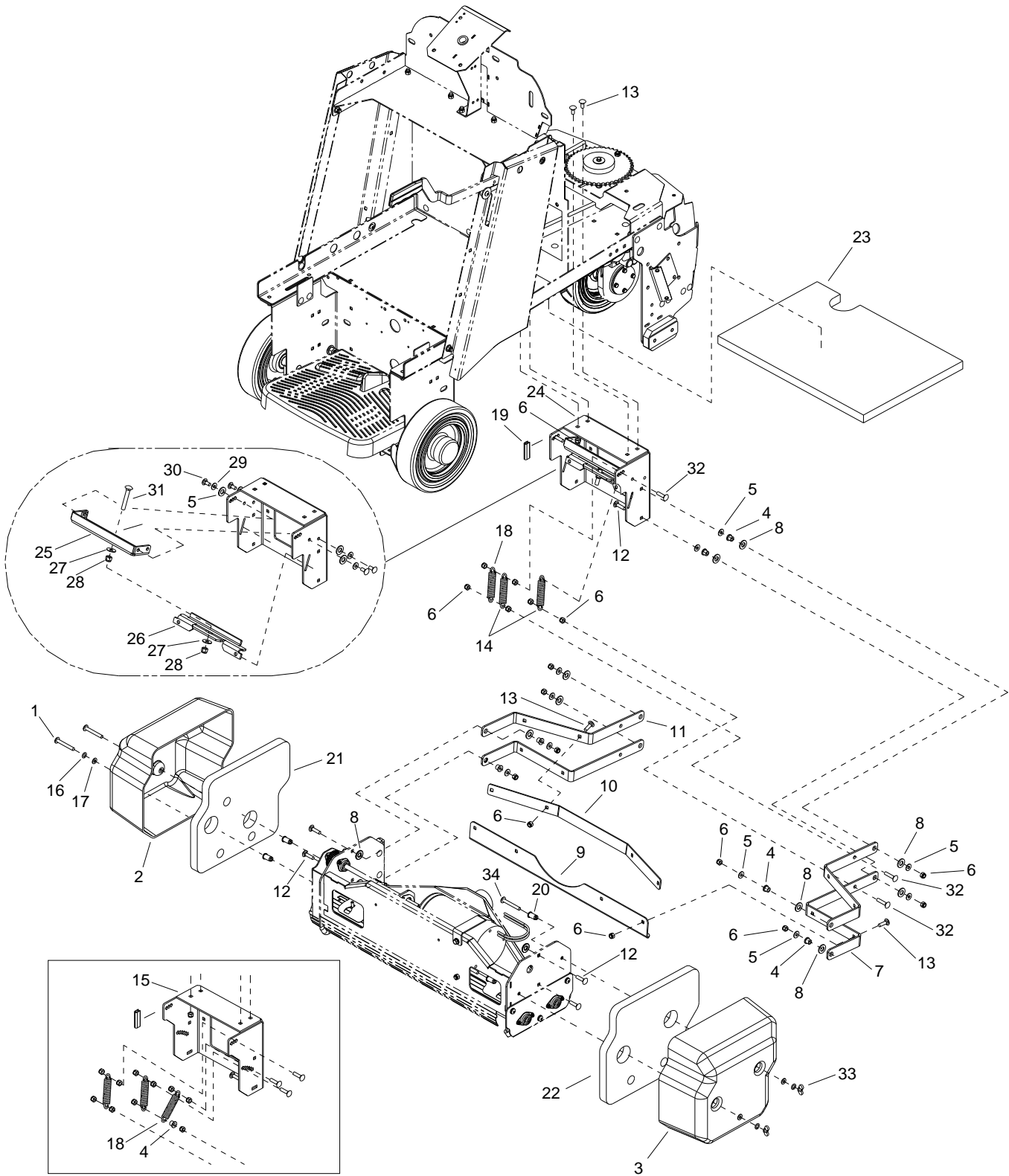

BRUSH DECK LINKAGE

REF	PART NO.	PRV NO.	QTY	DESCRIPTION	SERIAL NO. FROM	NOTES:
1	86273920	70049	4	SCR, 1/4-20 X 1.75 PPHMS SS		
2	86063340	270141	1	COVER, DECK SIDE, RIGHT		
3	86063350	270142	1	COVER, DECK SIDE, LEFT		
4	86228840	09124	6	BEARING, FLANGED .314ID X .502 OD		
5	86010670	87029	16	WASHER, 5/16 FLAT SS		
6	86270830	57023	28	NUT, 5/16-18 HEX NYLOCK SS		
7	86073550	51420	2	BRKT, HEAD ATTACH		
8	86259420	87232	10	WASHER, THRUST .51 ID X 1 OD BRO		
9	86068410	14838	1	BRACE, ANGLE		
10	86088730	14819	1	BAR, TIE, DECK		
11	86073560	51421	2	BRKT, HEAD ATTACH		
12	86277030	70780	8	SCR, 5/16-18 X 1.25 CARRIAGE SS		
13	86276070	70593	8	SCR, 5/16-18 X 3/4 CARRIAGE SS		
14	86255000	730385	4	SPRING, EXT. .75 OD X 3.5L		
15	86068420	29279	1	BRACKET, SCRUB DECK MOUNTING		
16	86010780	87162	4	WASHER, 1/4 SPLIT LOCK PLTD		
17	86010810	87191	4	WASHER, 1/4 ID X 1.0 OD FLAT SS		
18	86226830	73268	2	SPRING, EXT .68D X 3.00L X .098W		
19	86235410	78946	1	EDGING, 3/16" GRIP X 2.0 LG		
20	86189050	790464	4	NUT, WELL 1/4-20 HD		
21	86236560	43002	1	FOAM, SOUND INSUL, LFT CVR	*(2)	
22	86236550	43001	1	FOAM, SOUND INSUL, RT CVR	*(2)	
23	86236570	43003	1	FOAM, SOUND INSUL, UNDR CARR	*(2)	
24	86068360	141900	1	BRACKET, SCRUB DECK MOUNTING	*(3)	
25	86072210	141901	1	BRACKET, SPRING TENSIONER	*(3)	
26	86068370	141903	1	BRACKET, SPRING ANCHOR	*(3)	
27	86279510	87171	2	WASHER, 3/8 FLAT		
28	86271930	57297	2	NUT, 3/8-16 HEX NYLOCK SS		
29	86279130	87083	2	WASHER, 5/16 SPLIT LOCK PLTD		
30	86006560	70083	4	SCR, 5/16-18 X 1 HHCS SS NP		
31	86276870	70748	1	SCR, 3/8-16 X 2.50 CARRIAGE SS		
32	86276710	70717	6	SCR, 5/16-18 X 2.0 CARRIAGE SS		
33	86270900	57037	2	NUT, 1/4-20 WING SS	*(12)	
34	86276610	70697	2	SCR, 1/4-20 X 1.25 PPHMS SS	**	WAS 70049

* SEE SERIAL NUMBER PAGE

** CALL MANUFACTURER FOR SERIAL NUMBER

BRUSH DECK MOTOR & NOZZLE

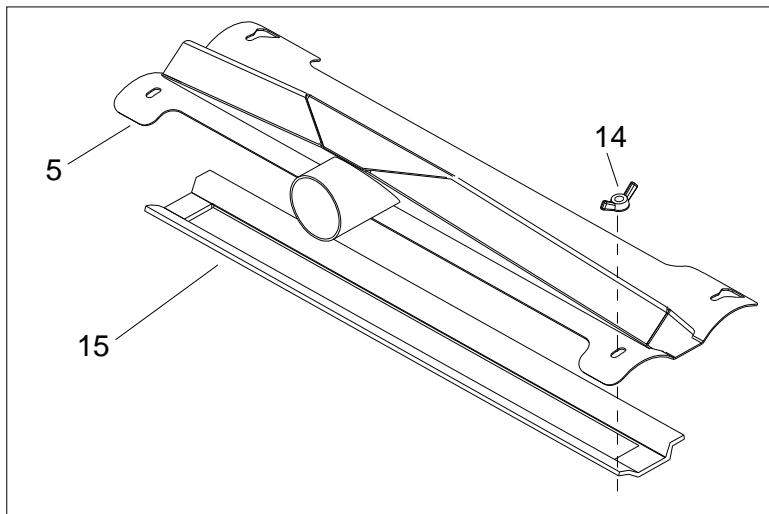
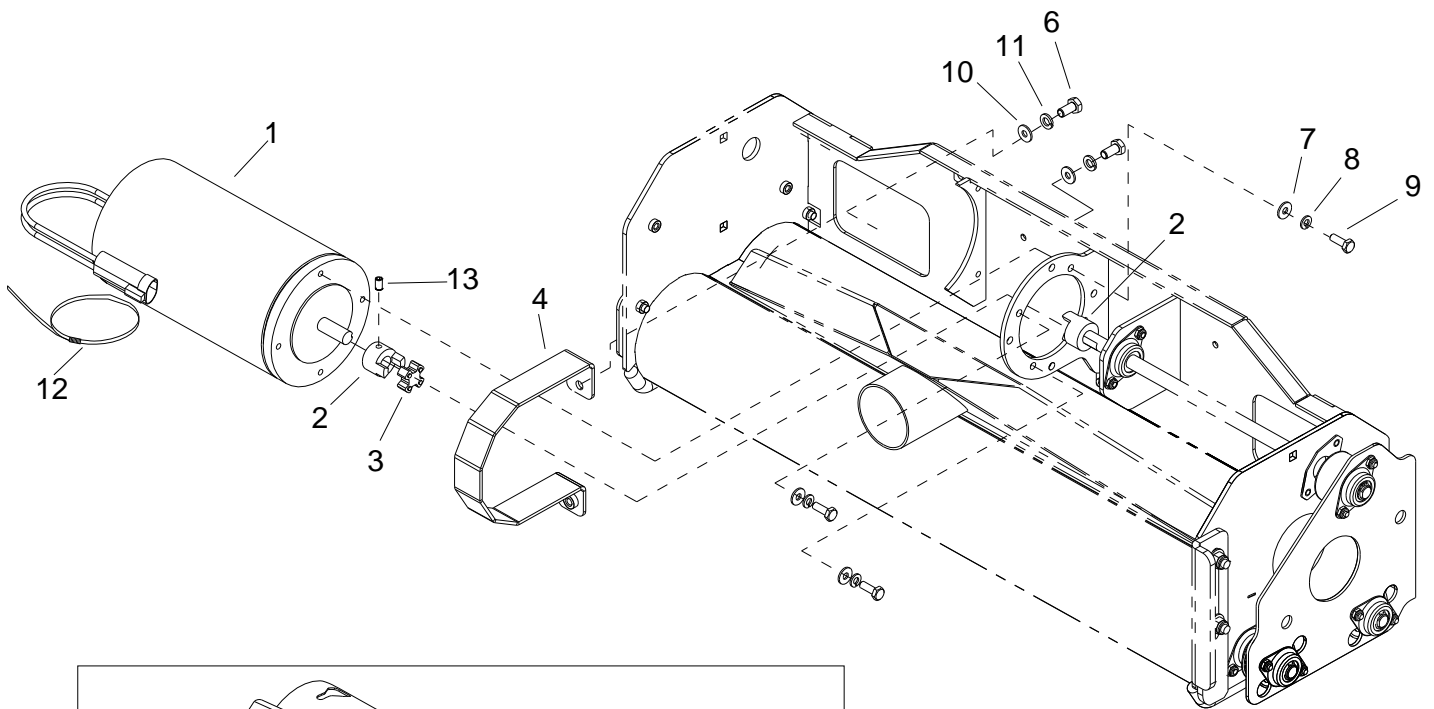

BRUSH DECK MOTOR & NOZZLE

REF	PART NO.	PRV NO.	QTY	DESCRIPTION	SERIAL NO. FROM	NOTES:
1	86222130	53275	1	MOTOR, 36VDC, 20A, .5HP	*(4)	WAS 53638
-	86332010	-	-	BRUSH SET FOR MOTOR 53275		
2	86234610	22112	2	COUPLER, .501 ID, 1/2 JAW "D"	*(4)	WAS 22108
3	86234600	22109	1	COUPLER, SPIDER, SHL070, HYTREL		
4	86088100	730403	1	STRAP, BRUSH MOTOR		
5	86078040	58006	1	NOZZLE, VACUUM	*(5)	
6	86276780	70728	2	SCR, 5/16-18 X 3/4 HHCS SS		
7	86010630	87013	3	WASHER, 1/4 ID X 5/8 OD SS		
8	86010780	87162	3	WASHER, 1/4 SPLIT LOCK PLTD		
9	86273780	70015	3	SCR, 1/4-20 X 3/4 HHCS SS NP		
10	86010670	87029	2	WASHER, 5/16 FLAT SS		
11	86279130	87083	2	WASHER, 5/16 SPLIT LOCK PLTD		
12	86264940	27051	2	CABLE TIE, 11.38" UL/CSA		
13	86277930	70119	2	SET SCR, 1/4-20 X 3/8 KCP DL		
14	86271720	57246	4	NUT, 1/4-20 WING NYLOCK ZINC	*(5)	
15	86238060	36247	1	GASKET, 3.50 W X 25.75L X .19T	*(5)	

* SEE SERIAL NUMBER PAGE

BRUSH DECK LIFT

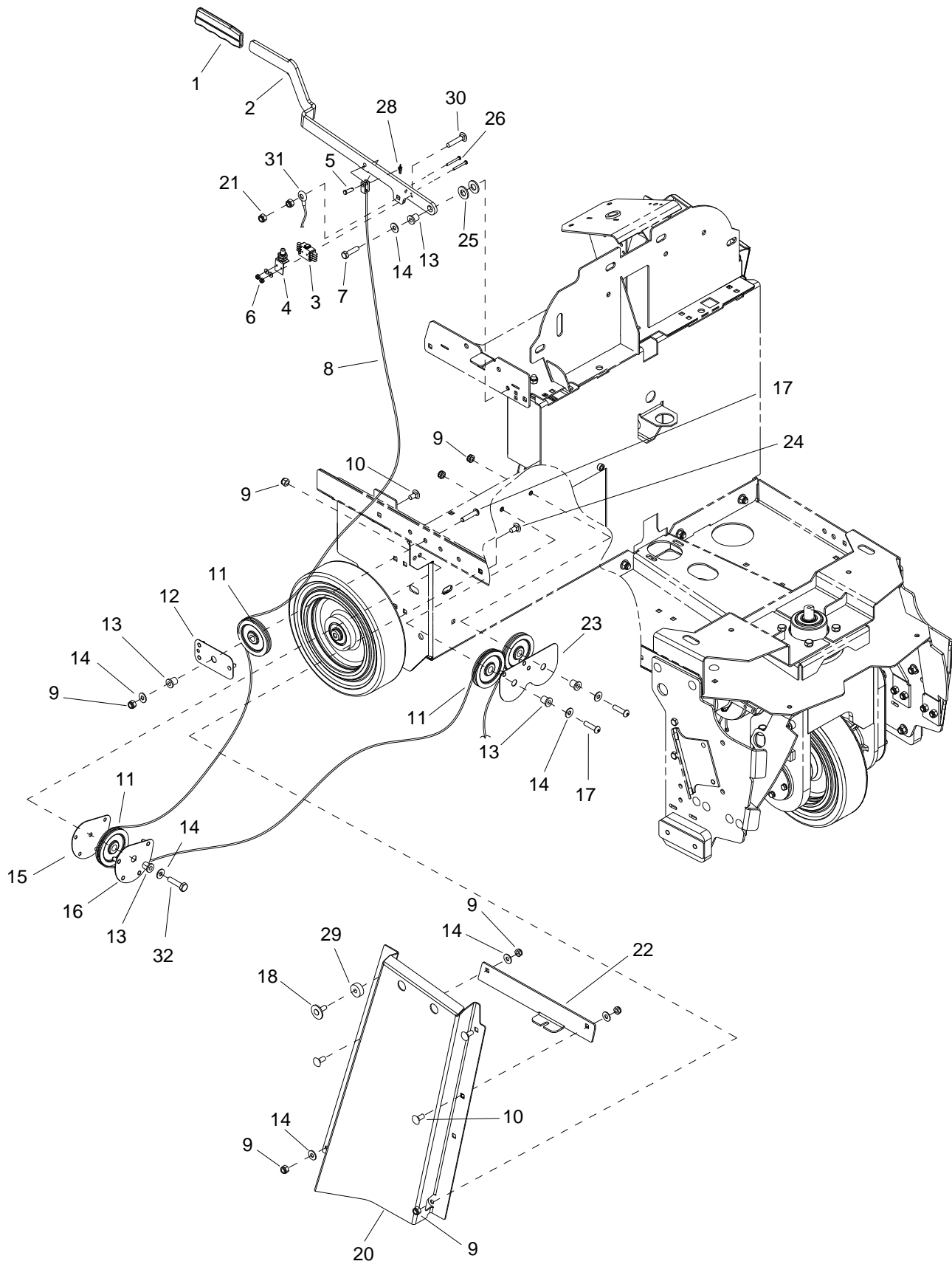

BRUSH DECK LIFT

REF	PART NO.	PRV NO.	QTY	DESCRIPTION	SERIAL NO. FROM	NOTES:
1	86238350	36214	1	GRIP, 3/16 X 1.00 BLUE		
2	86076610	38319	1	HANDLE, SQUEEGEE LIFT		
3	86257170	72200	1	SWITCH, DPDT, SNAP ACTION		
4	86250240	72201	1	PLUNGER, SWITCH, OVERTRAVEL		
5	86009560	82053	1	PIN, CLEVIS 1/4 X .63 PLTD		
6	86271660	57233	2	NUT, 4-40 HEX NYLOCK		
7	86007020	70673	1	SCR, 5/16-18 X 1.25 HHCS SS NP		
8	86231570	270105	1	CABLE, SQG LIFT SCRUBPLUS		
9	86270830	57023	8	NUT, 5/16-18 HEX NYLOCK SS		
10	86276070	70593	2	SCR, 5/16-18 X 3/4 CARRIAGE SS		DELUXE ONLY
11	86223370	66464	4	PULLEY, PLASTIC 3.0 DIA.		
12	86073600	66833	1	BRKT, PULLEY RETAINER, SINGLE		
13	86231150	09151	5	BUSHING FLANGE, .314 ID X.502 OD		
14	86010670	87029	8	WASHER, 5/16 FLAT SS		
15	86083500	66832	1	PLATE, PULLEY RETAINER, CORNER		
16	86083490	66831	1	PLATE, PULLEY MOUNT, CORNER		
17	86276760	70724	4	SCR, 5/16-18 X 1.25 BSHCS SS		
18	86066130	89501	1	ASM, HANDLE RETAINER	*(6)	
19	OPEN	-	-	-	-	-
20	86091820	140807	1	BRKT, SIDE CHANNEL R		
21	86271840	57285	2	NUT, 5/16-18 HEX NYLOCK THIN SS		DELUXE ONLY
22	86068400	14623	1	BRKT, CABLE MOUNT		DELUXE ONLY
23	86083440	66824	1	PLATE, PULLEY MOUNTING, CENTER		
24	86277460	70847	1	SCR, 5/16-18 X 5/8 BSHCS SS		
25	86259420	87232	2	WASHER, THRUST .51 ID X 1 OD BRO		
26	86276010	70580	2	SCR, 4-40 X 1.0 PPHMS		
27	86279450	87161	2	WASHER, #6 FLAT SAE PLTD		
28	86008650	80604	1	COTTER, 1/4" RING		
29	86254280	730331	1	SPACER, 1.00 OD X .32 ID X .375		
30	86277130	70795	1	SCR, 5/16-18 X 1.00 CARRIAGE SS		DELUXE ONLY
31	86231760	27725	1	CABLE ASM, SQUEEGEE TC		DELUXE ONLY

* SEE SERIAL NUMBER PAGE

BUMPER

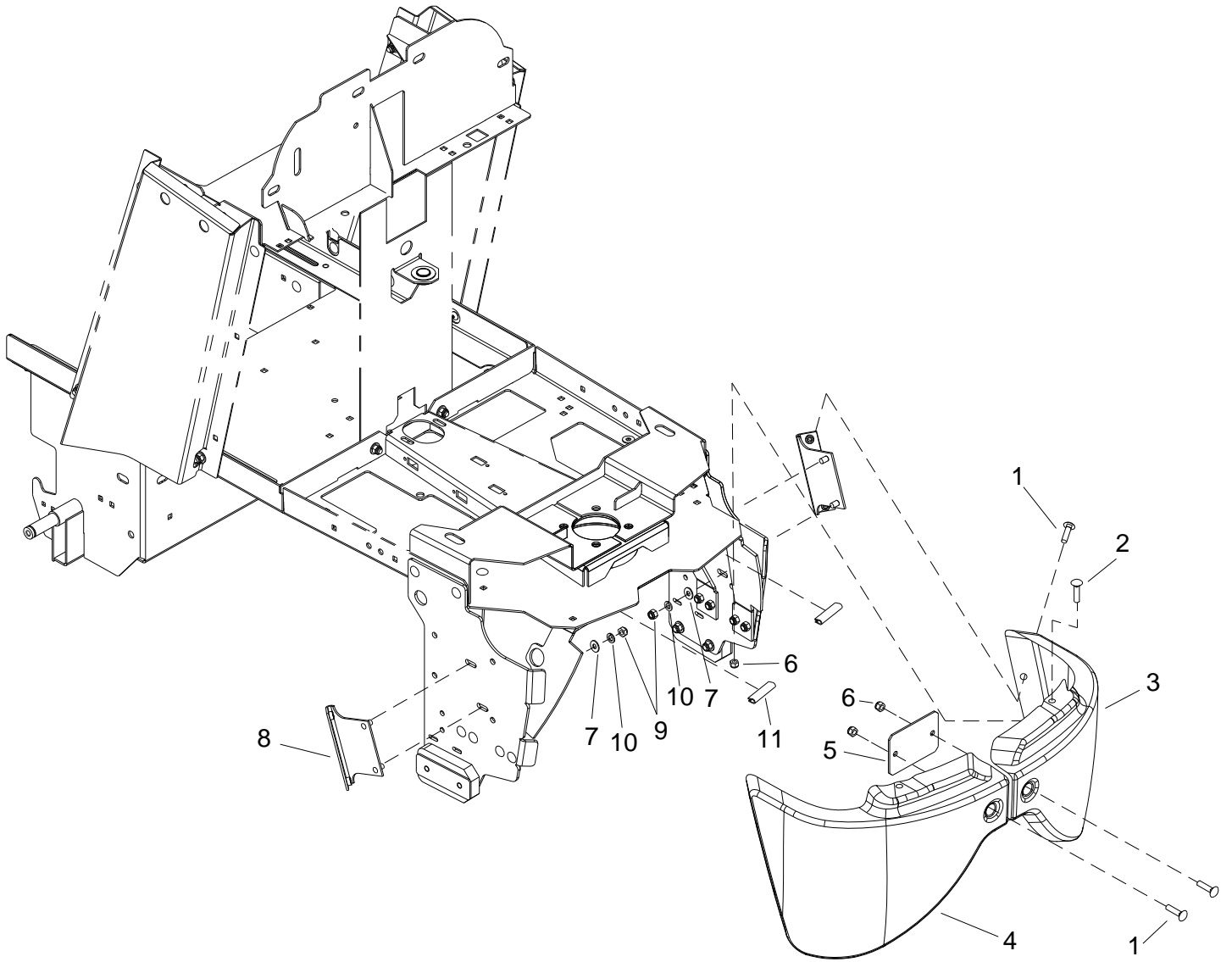

BUMPER

REF	PART NO.	PRV NO.	QTY	DESCRIPTION	SERIAL NO. FROM	NOTES:
1	86276890	70752	6	SCR, 5/16-18X3/4 PTHMS SS		
2	86007070	70849	2	SCR, 5/16-18 X 1.00 PPHMS SS		
3	86063230	140813	1	BUMPER, LEFT		
4	86063240	140814	1	BUMPER, RIGHT		
5	86071020	140783	1	BRKT, FRONT BUMPER		
6	86270830	57023	4	NUT, 5/16-18 HEX NYLOCK SS		
7	86010670	87029	4	WASHER, 5/16 FLAT SS		
8	86070730	140729	2	BRKT, BUMPER MOUNT, SIDE		
9	86197040	57264	4	NUT, 5/16-18 HEX ACORN PLTD		
10	86279130	87083	4	WASHER, 5/16 SPLIT LOCK PLTD		
11	86251750	67602	2	RISER, BUMPER		

CONTROL PANEL

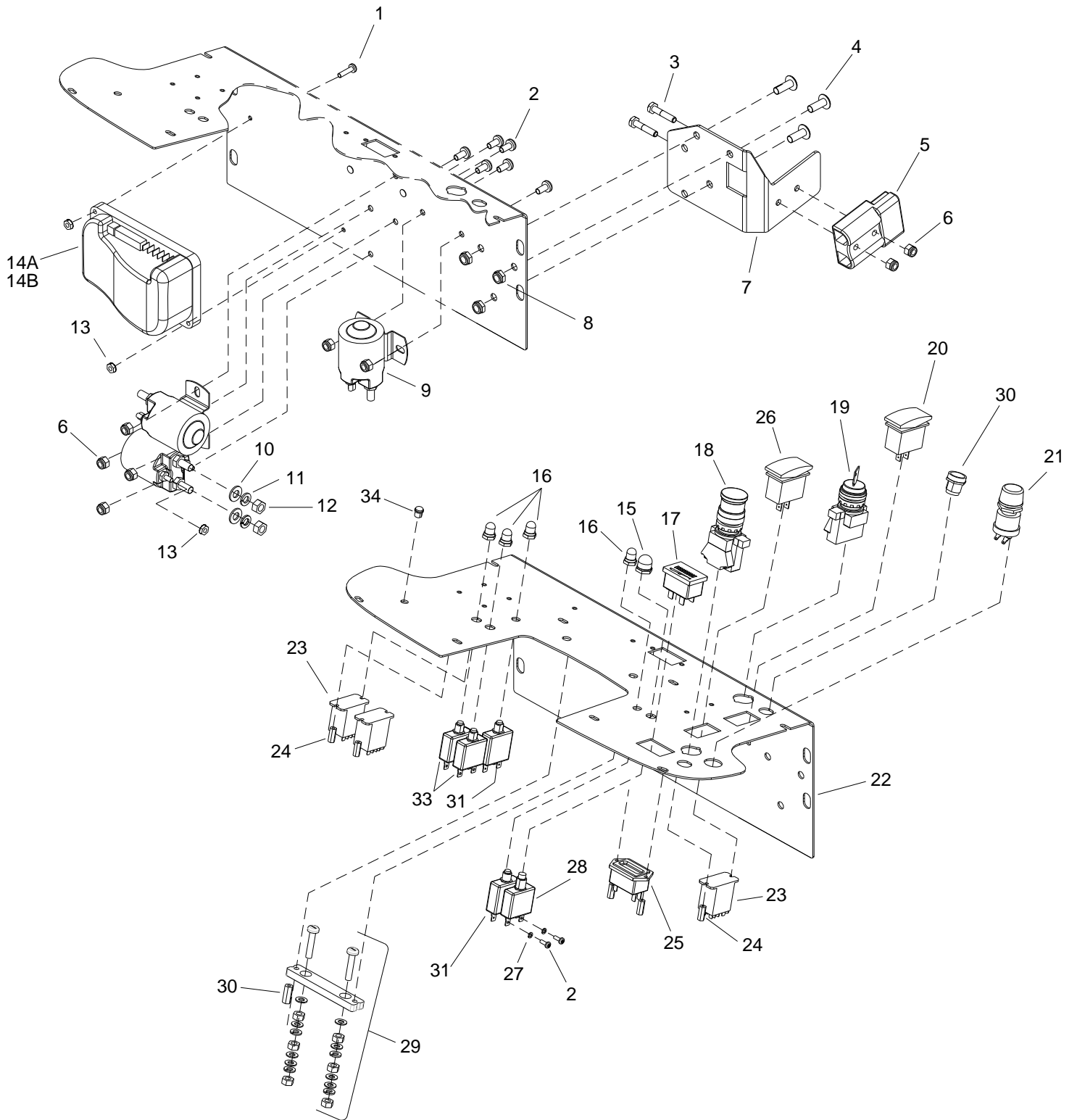

CONTROL PANEL

REF	PART NO.	PRV NO.	QTY	DESCRIPTION	SERIAL NO. FROM	NOTES:
1	86273980	70066	2	SCR, 10-32 X 3/4 PPHMS SS		
2	86223740	70872	6	SCR, 1/4-20 X .59 PPHMS SSC		
3	86273820	70019	2	SCR, 1/4-20 X 1.25 HHCS SS		
4	86277480	70850	3	SCR, 5/16-18 X 1/2 PTHMS SS		
5	86008760	80682	1	CONN, 175 DCA GRY W/O TERMS		
6	86005810	57245	8	NUT, 1/4-20 HEX NYLOCK SS		
7	86070720	140728	1	BRKT, BATT CONN BASIC		
8	86271840	57285	3	NUT, 5/16-18 HEX NYLOCK THIN SS		
9	86006370	67315	3	RELAY, 36VDC 100 AMP HVY DUTY		
10	86010670	87029	6	WASHER, 5/16 FLAT SS		
11	86279130	87083	6	WASHER, 5/16 SPLIT LOCK PLTD		
12	86271120	57125	6	NUT, 5/16-18 BRASS		
13	86005700	57104	5	NUT, 10-32 W/STAR WASHER PLTD		
14A	86002760	270092	1	CONTROLLER, CHAIN DRIVE BASIC		CHAIN DRIVE ONLY
14B	86027740	27911	1	CONTROLLER, GEAR BASIC	**	GEAR DRIVE ONLY
15	86008900	80845	1	BOOT, SEAL-PUSH BUTTON 7/16-28		
16	86002010	14942	4	BOOT, 3/8 CIRCUIT BREAKER		BASIC (3) DELUXE (4)
17	86005560	54199	1	METER, 36V LED BATTERY		
18	86007180	72160	1	SWITCH, EMERGENCY STOP		
19	86007190	72161	1	SWITCH KEY DPST		
20	86007130	72128	1	SWITCH, DPDT 2-POSITION ROCKER		
21	86257280	81371	1	SWITCH, PUSH BUTTON		
22	86078180	61481	1	PANEL, VACUUM		
23	86251410	67506	3	RELAY, 15A 36V MINI		
24	86255900	73538	10	STANDOFF, 6-32 X 5/8 HEX NYL		
25	86005530	54154	1	METER, 12-48 VDC LED HOUR		
26	86257110	72189	1	SWITCH, 4P3T FIXED POS ROCKER		
27	86279300	87134	2	WASHER, #6 LOCK		
28	86001910	14606	1	BREAKER, 30A 50VDC CIRCUIT		
29	86229770	140805	1	BLOCK, SHUNT MOUNT		
30	86257140	72196	1	SWITCH ASM, SEALED PB RND GRN		
31	86002000	14717	2	BREAKER, 3 AMP 1681-090-300		BASIC (1) DELUXE (2)
32	86250210	66873	1	PLUG, DOME .375		BASIC (NOT SHOWN)
33	86230080	141044	2	BREAKER, 22A 250VAC, 50VDC	*(4)	
34	86246630	82996	1	LIGHT, INDICATOR, RED		

* SEE SERIAL NUMBER PAGE

** CALL MANUFACTURER FOR SERIAL NUMBER

CONTROL PANEL HOUSING

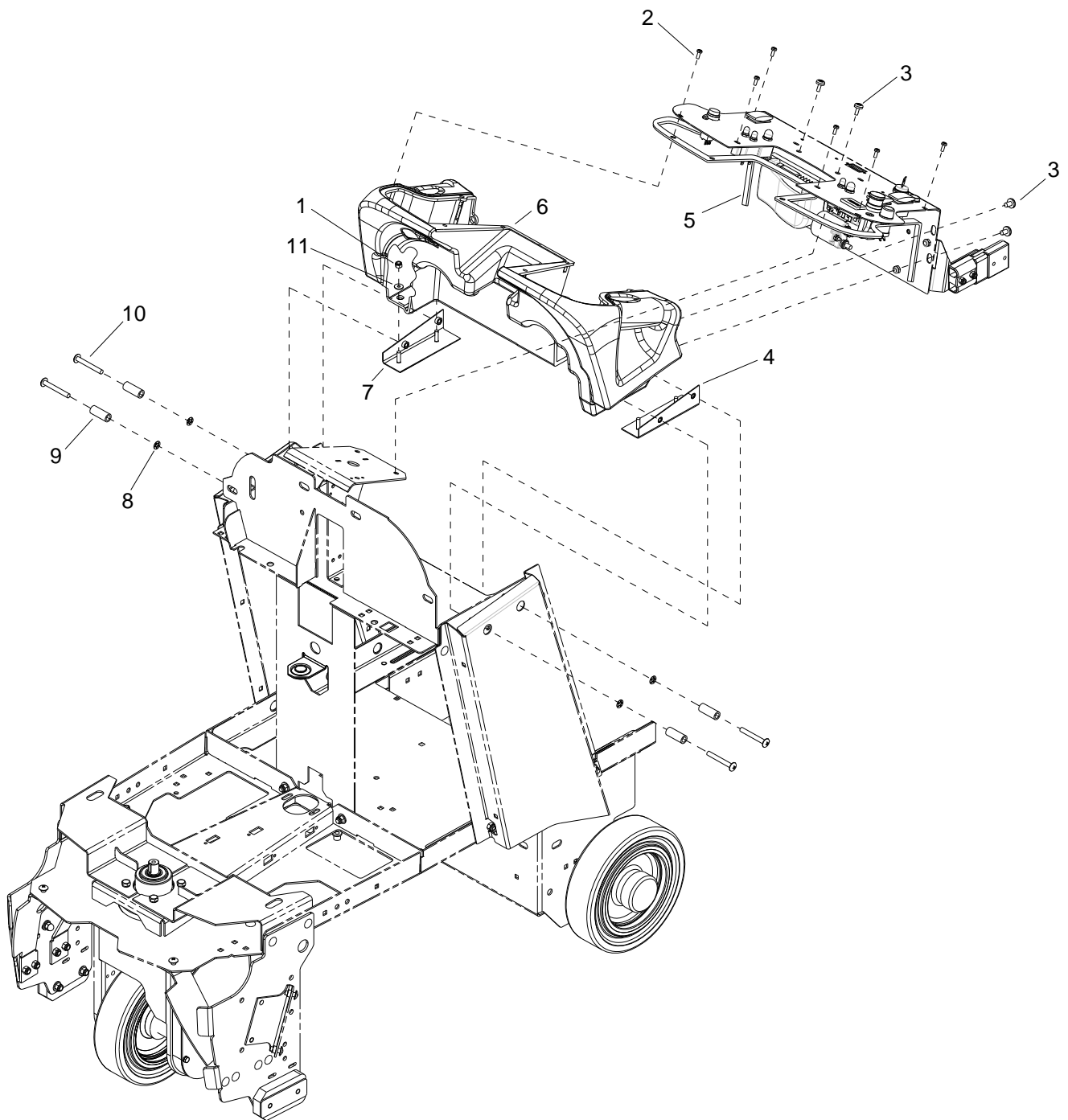

CONTROL PANEL HOUSING

REF	PART NO.	PRV NO.	QTY	DESCRIPTION	SERIAL NO. FROM	NOTES:
1	86005810	57245	4	NUT, 1/4-20 HEX NYLOCK SS		
2	86290540	-	6	SCR, 10-32 X 1/2 TORX SS BLK NP		
3	86277480	70850	6	SCR, 5/16-18 X1/2 PTHMS SS		
4	86070710	140726	1	BRKT, LEFT CONSOLE MOUNT		
5	86237900	35278	3	GASKET, .125T X .25W X 23L		
6	86062220	270117	1	CONSOLE, BURNISHER		
7	86070700	140725	1	BRKT, RIGHT CONSOLE MOUNT		
8	86279750	87252	4	WASHER, RET, PUSHNUT, 5/16 BOLT		
9	86089650	78524	4	TUBE, 5/8 OD X .357 ID X 1.57		
10	86277420	70841	4	SCR, 5/16-18 X 2.5 PTHMS SS		
11	86010630	87013	4	WASHER, 1/4 ID X 5/8 OD SS		

DECAL

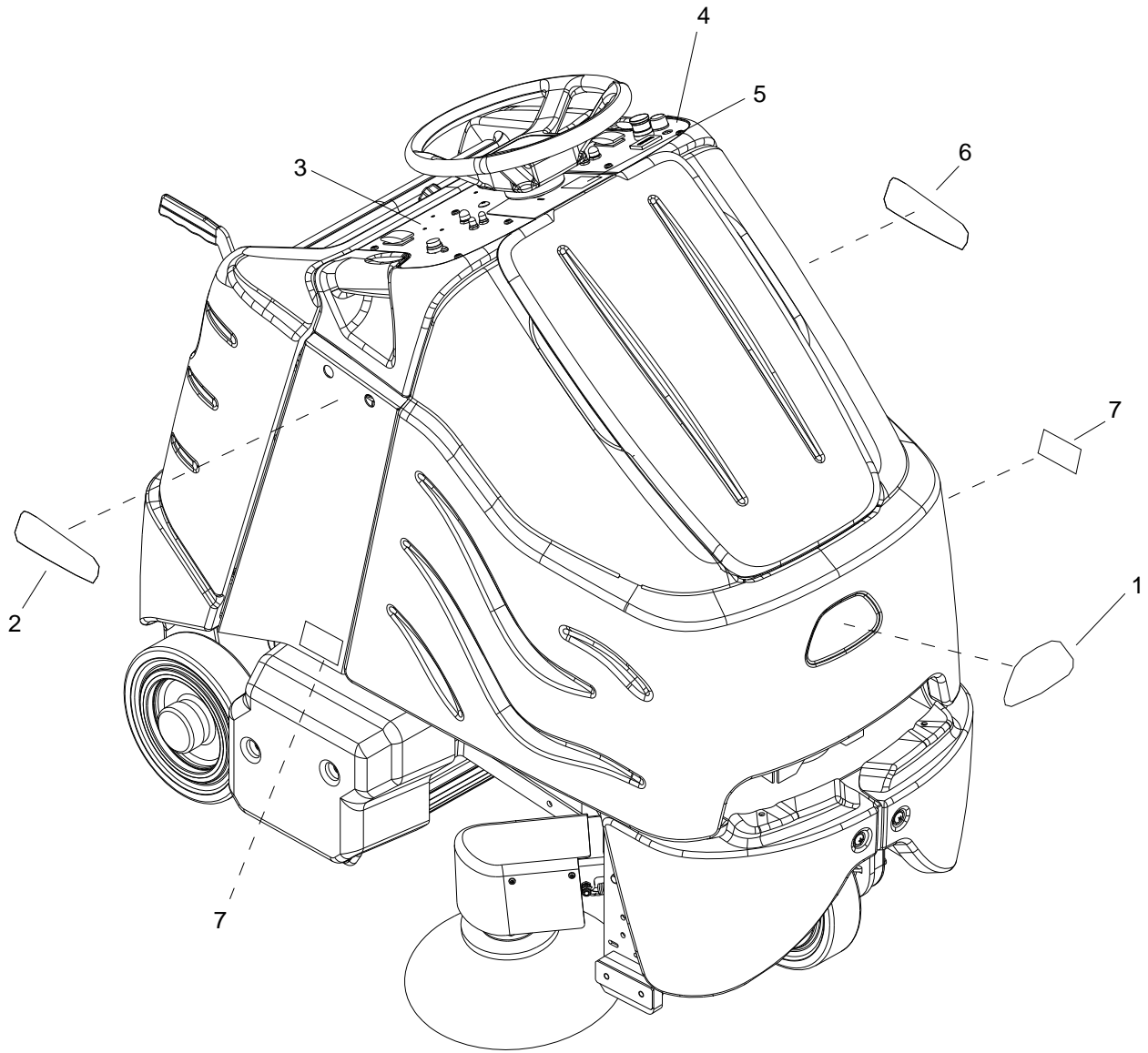

DECAL

REF	PART NO.	PRV NO.	QTY	DESCRIPTION	SERIAL NO. FROM	NOTES:
1	86004970	50990	1	LABEL, WINDSOR LOGO DOMED		
2	86244800	501228	1	LABEL, CHARIOT IVACUUM RT		WAS 500884
3	86244360	501071	1	LABEL, PANEL R VAC		
4	86244190	500882	1	LABEL, PANEL BASIC LEFT		
5	86243990	500780	1	LABEL, COVER PANEL		
6	86244810	501229	1	LABEL, CHARIOT IVACUUM LT		WAS 500885
7	86334860	-	2	LABEL, HEPA FILTRATION	*(18)	

NOTE: See "SAFETY LABEL LOCATION" page for safety label information.

* SEE SERIAL NUMBER PAGE

FRAME-LOWER

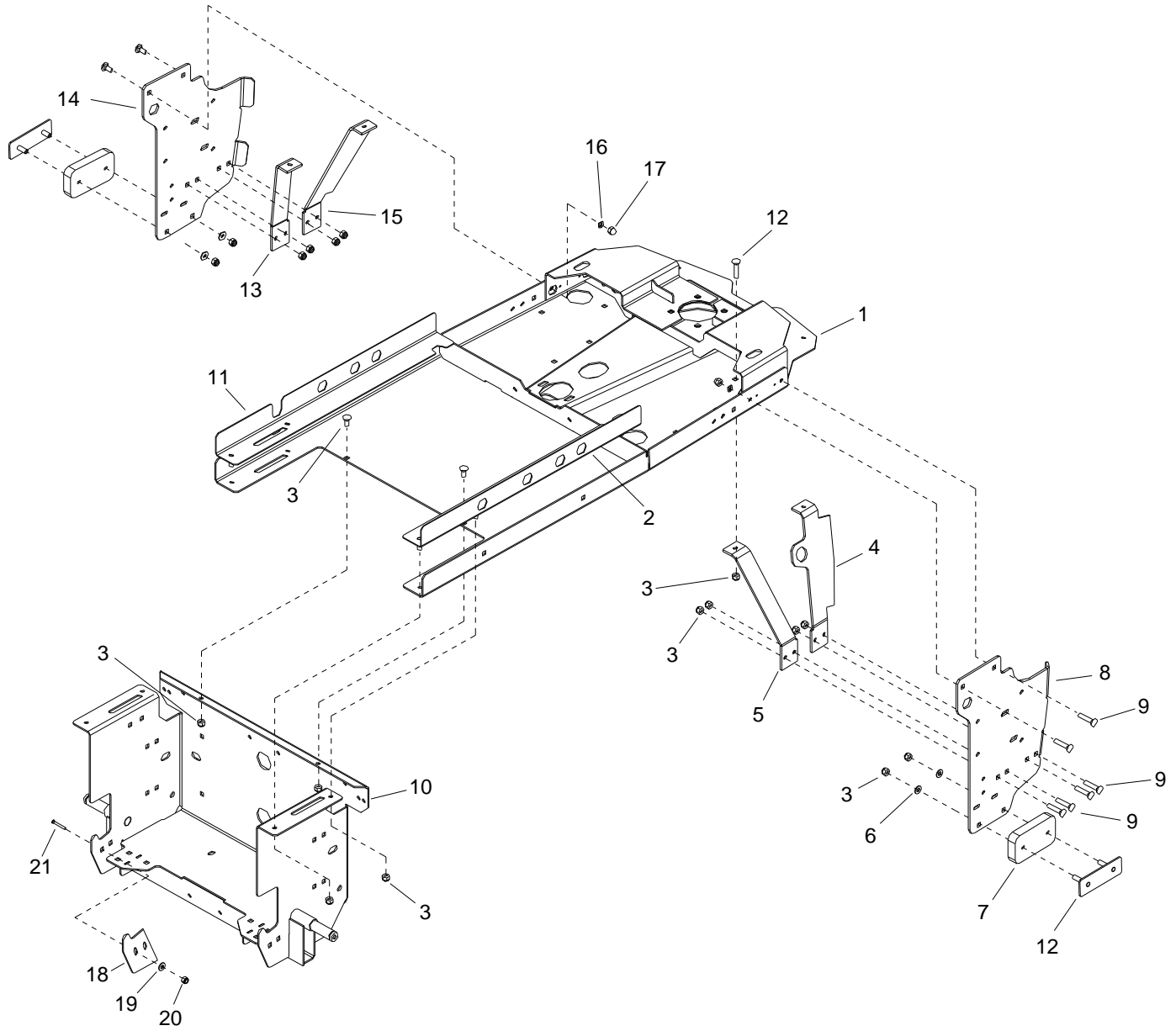

FRAME-LOWER

REF	PART NO.	PRV NO.	QTY	DESCRIPTION	SERIAL NO. FROM	NOTES:
1	86092510	34440	1	FRAME, MAIN ASM		
2	86088760	75458	1	TRAY, SLIDE, LEFT		
3	86270830	57023	18	NUT, 5/16-18 HEX NYLOCK SS		
4	86071430	140863	1	BRKT, BRACE, RGT FRONT		
5	86071120	140811	1	BRKT, TIP BRACE, RIGHT, REAR		
6	86010670	87029	4	WASHER, 5/16 FLAT SS		
7	86064300	140790	2	PAD, TIPPING BAR		
8	86070740	140730	1	BRKT, LINKAGE, RIGHT		
9	86276070	70593	16	SCR, 5/16-18 X 3/4 CARRIAGE SS		
10	86091420	05251	1	AXLE, REAR WELDMENT		
11	86088750	75457	1	TRAY, SLIDE, RIGHT		
12	86079320	620101	2	PLATE, PAD RETAINER		
13	86071130	140812	1	BRKT, TIP BRACE, LEFT, REAR		
14	86070750	140731	1	BRKT, LINKAGE, LEFT		
15	86070760	140733	1	BRKT, BRACE, LEFT FRONT		
16	86279130	87083	4	WASHER, 5/16 SPLIT LOCK PLTD		
17	86197040	57264	4	NUT, 5/16-18 HEX ACORN PLTD		
18	86079290	620097	2	PLATE, REAR COVER ADJ.		
19	86010630	87013	4	WASHER, 1/4 ID X 5/8 OD SS		
20	86271870	57290	4	NUT, 1/4-20 HEX NYLOCK THIN SS		
21	86276950	70772	4	SCR, 1/4-20 X 3/4 CARRIAGE SS		

FRAME-UPPER

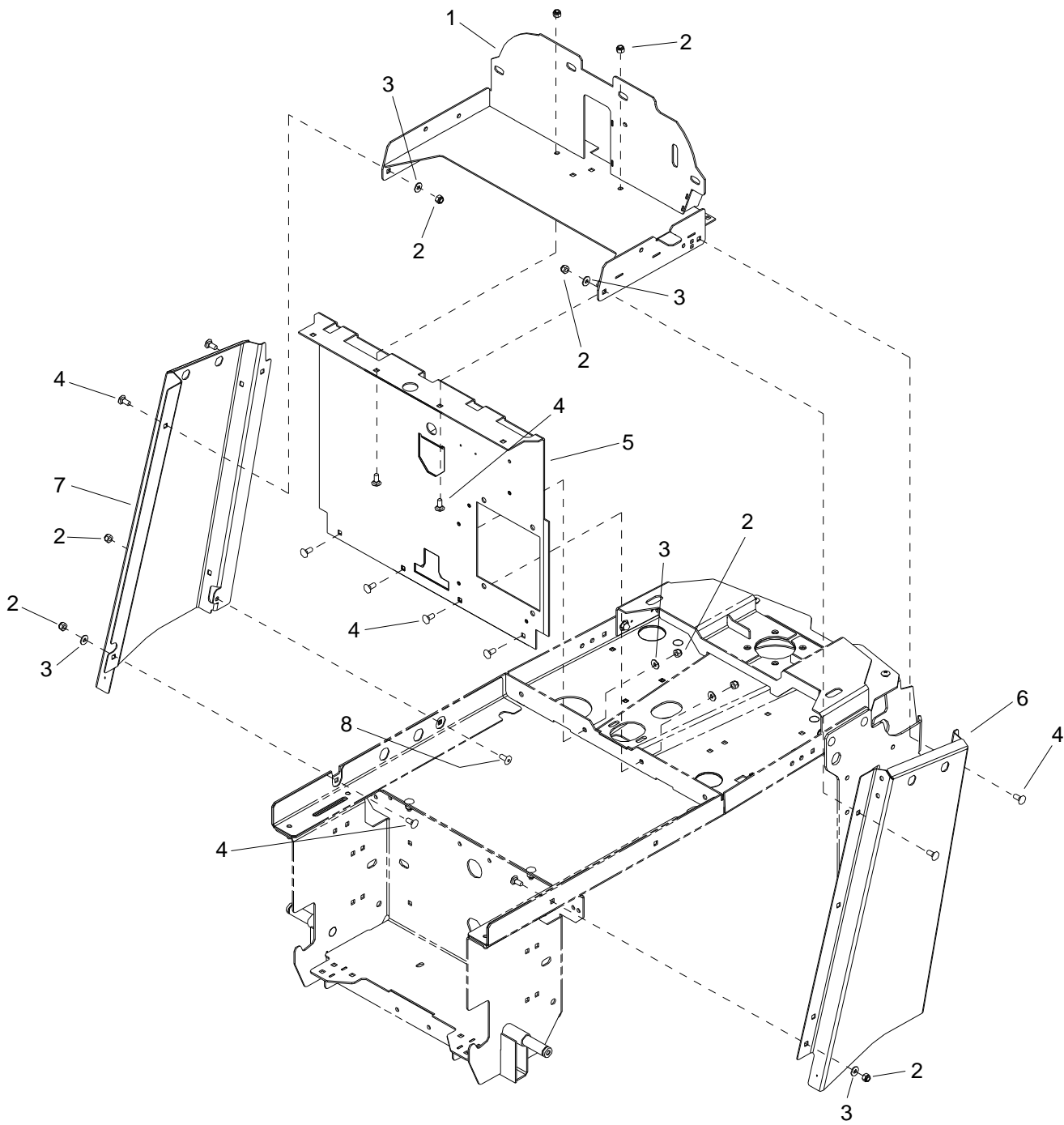

FRAME-UPPER

REF	PART NO.	PRV NO.	QTY	DESCRIPTION	SERIAL NO. FROM	NOTES:
1	86071360	140855	1	BRKT, HORIZ ELECT, BURNISHER		
2	86270830	57023	13	NUT, 5/16-18 HEX NYLOCK SS		
3	86010670	87029	12	WASHER, 5/16 FLAT SS		
4	86276070	70593	12	SCR, 5/16 X 3/4 CARRIAGE SS		
5	86078620	14023	1	BRKT, VERTICAL SUPPORT		
6	86091820	140807	1	BRKT, SIDE CHANNEL R		
7	86073500	270090	1	BRKT, SIDE CHANNEL L		
8	86277460	70847	1	SCR, 5/16-18 X 5/8 BSHCS SS		

HOOD

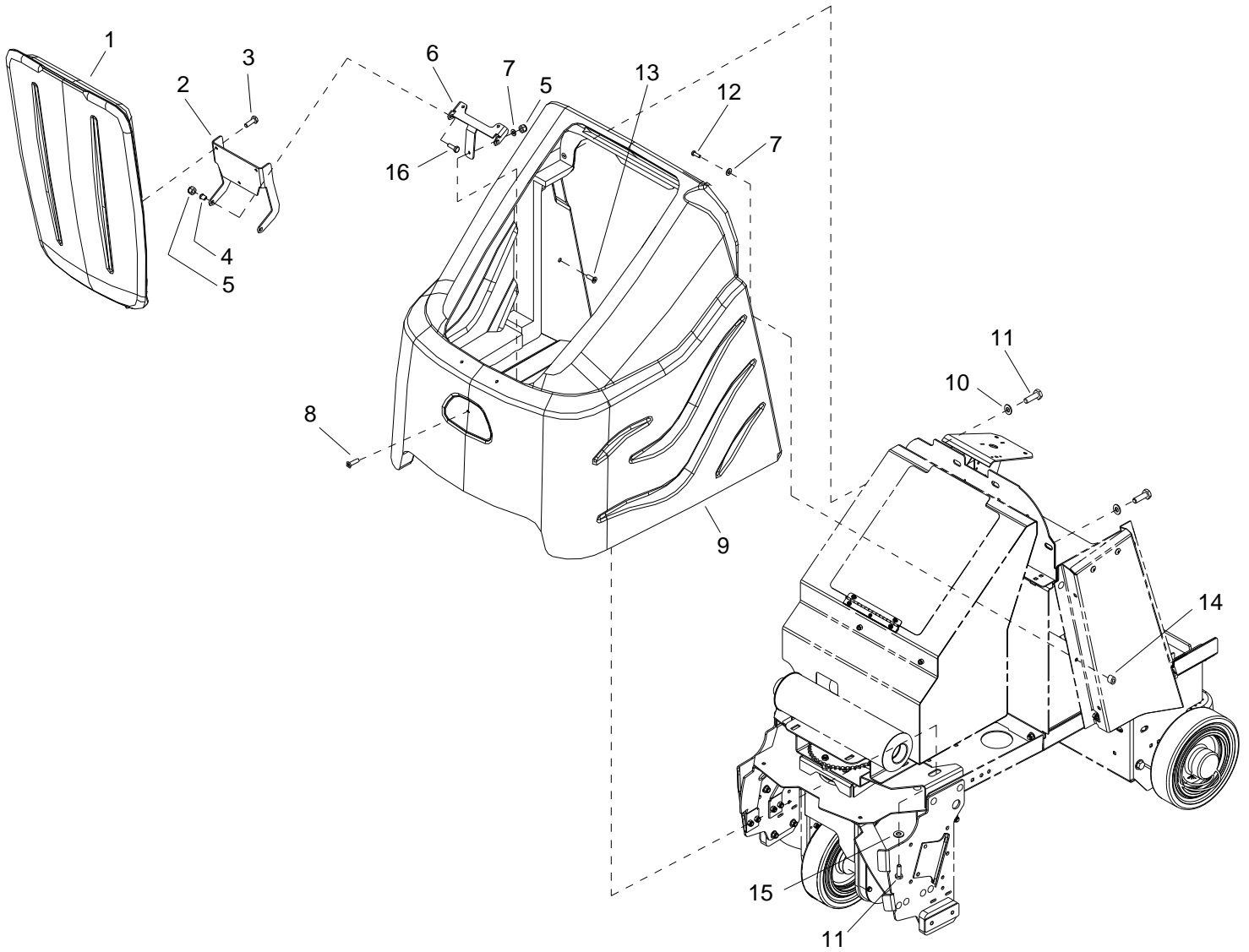

HOOD

REF	PART NO.	PRV NO.	QTY	DESCRIPTION	SERIAL NO. FROM	NOTES:
1	86293630	-	1	LID, VACUUM		
2	86076720	41534	1	HINGE, LID		
3	86273830	70020	3	SCR, 1/4-20 X 1/2 HHCS SS NP		
4	86226370	14493	2	BUSH, BRZ FLG .25 X .38 X .38		
5	86005810	57245	2	NUT, 1/4-20 HEX NYLOCK SS		
6	86076710	41533	1	HINGE, TANK		
7	86010630	87013	5	WASHER, 1/4 ID X 5/8 OD SS		
8	86006840	70390	3	SCR, 1/4-20 X 1 FHCS PLTD		
9	86032920	75482	1	TANK, VACUUM BODY COVER		
10	86279630	87212	4	WASHER, .344 ID X 1.13 OD X .09 T PLT		
11	86006760	70305	6	SCR, 5/16-18 X 3/4 HHCS GR5 PLTDL		
12	86273820	70019	2	SCR, 1/4-20 X 1.25 HHCS SS		
13	86250250	66286	2	PLUSNUT, 1/4-20 FLATHEAD		
14	86254280	730331	2	SPACER, 1.00 OD X .32 ID X .375		
15	86279630	87212	2	WASHER, .344 ID X 1.13 OD X .09 T PLT		
16	86273780	70015	2	SCR, 1/4-20 X 3/4 HHCS SS NP		

PEDAL PLATFORM-From Serial Number (17*)

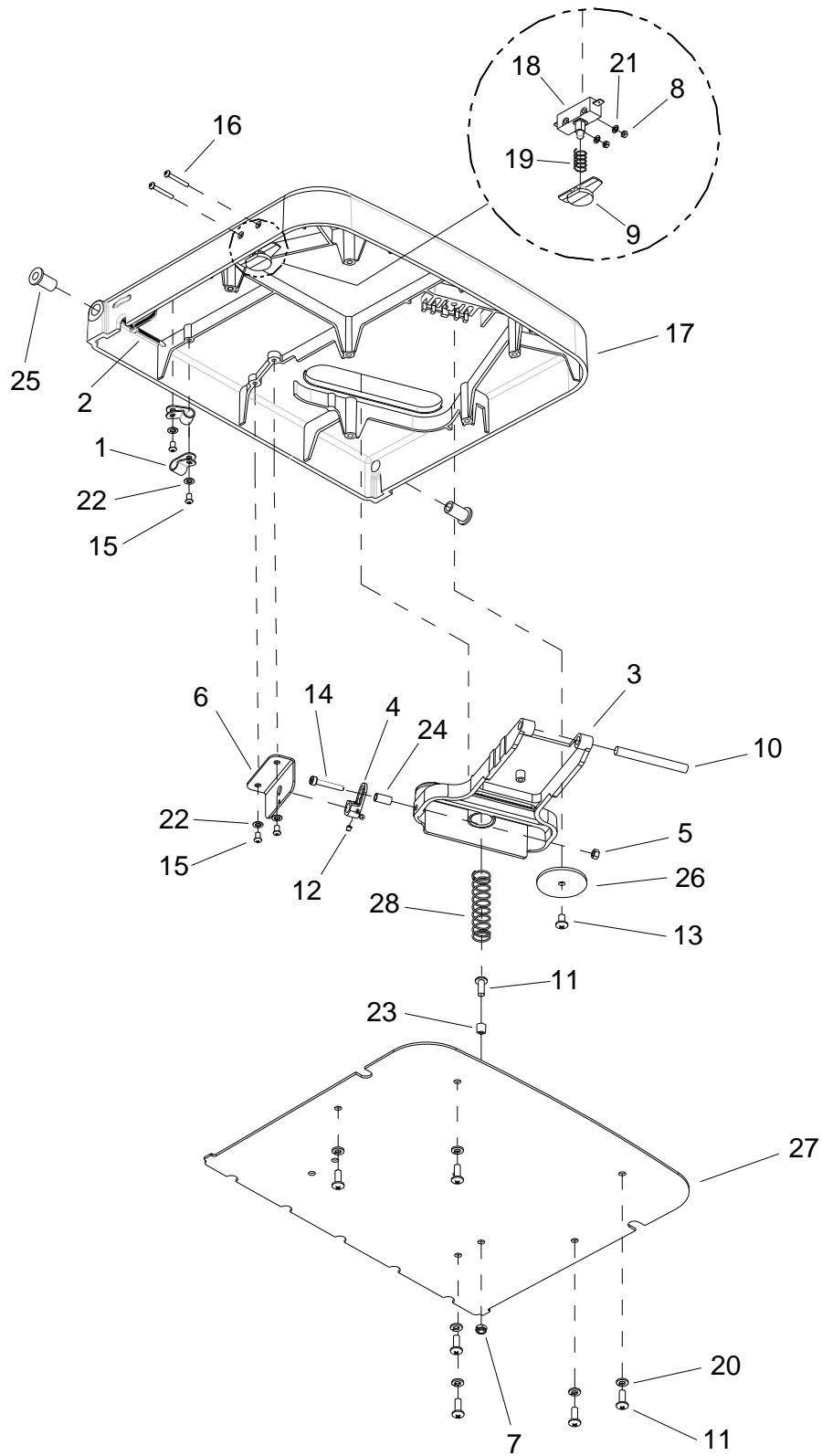

PEDAL PLATFORM-From Serial Number (17*)

REF	PART NO.	PRV NO.	QTY	DESCRIPTION	SERIAL NO. FROM	NOTES
1	86233170	20054	2	CLAMP, 3/8 NYLON UL/CSA		
2	86264920	27049	1	CABLE TIE, .19 X 7 UL/CSA		
3	86222510	34430	1	PEDAL, THROTTLE		
4	86221850	34433	1	LINK, THROTTLE		
5	86136310	57086	1	NUT, M5 HEX		
6	86312820	-	1	BRACKET, POT, SPEED		
7	86288720	57277	1	NUT, M6 NYLOCK PLATED		
8	86272040	57503	2	NUT, M3.5 X 2.8 HEX		
9	86223260	66085	1	PLUNGER, PLATFORM SWITCH		
10	86223580	67502	1	ROD, PIVOT, 8.5MM X 77		
11	86274340	70179	7	SCR, M6 X 16 PH		
12	86278060	70759	2	SET SCR, M4 X 4MM NP		
13	86277360	70833	1	SCR, M6 X 10 PH		
14	86277370	70834	1	SCR, M5 X 30 SHCS		
15	86277380	70835	4	SCR, M4.8 X 16 PHTF		
16	86277390	70836	2	SCR, M3.5 X 38 PH		
17	86312770	-	1	PLATFORM		
18	86007110	72123	1	SWITCH, 25A SPST 125-250V SNAP		
19	86224750	73993	1	SPRING, COMP, .48OD X .91L		
20	86279140	87085	6	WASHER, M6 SPLIT LOCK DIN127B		
21	86279720	87248	2	WASHER, M4 INT STAR		
22	86279730	87249	4	WASHER, M5 INT STAR		
23	86224360	730325	1	SPACER 12.7MMOD X 2.78W X 6L		
24	86224350	730305	1	SPACER, 8MM X 16LG		
25	86333280	-	2	BUSHING, 8MM X 10 LG SS		
26	86222780	620047	1	PLATE, PIVOT		
27	86222810	620050	1	PLATE, COVER		
28	86254970	730304	1	SPRING, COMP 18MM OD X 83 X 2		

NOTE: Complete platform assembly is available, Part No. 86028310.

**CALL MANUFACTURER FOR SERIAL NUMBER

*See Serial Number page.

PEDAL PLATFORM-To Serial Number (17*)

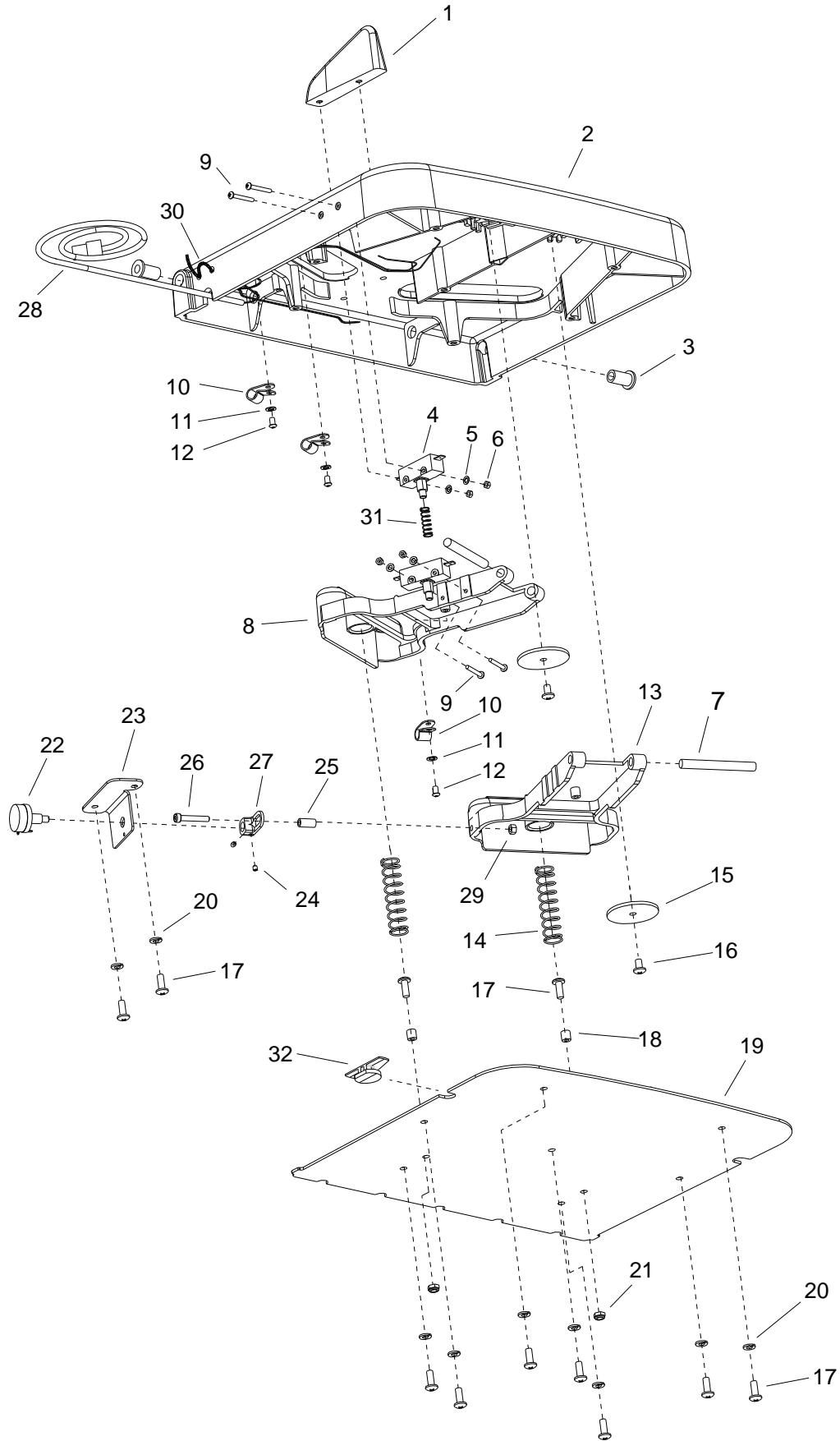

PEDAL PLATFORM-To Serial Number (17*)

REF	PART NO.	PRV NO.	QTY	DESCRIPTION	SERIAL NO. FROM	NOTES:
1	86217650	34432	1	DIVIDER		
2	86222700	34429	1	PLATFORM		
3	86216380	140713	2	BUSHING, 8MM X 10LG CLY		
4	86007110	72123	2	SWITCH, 25A SPST 125-250V SNAP		
5	86279720	87248	4	WASHER, M4 INT STAR		
6	86272040	57503	4	NUT, M3.5 X 2.8 HEX		
7	86223580	67502	2	ROD, PIVOT, 8.5MM X 77		
8	86222520	34431	1	PEDAL, BRAKE		
9	86277390	70836	4	SCR, M3.5 X 38 PHMS		
10	86233170	20054	3	CLAMP, 3/8 NYLON UL/CSA		
11	86279730	87249	4	WASHER, M5 INT STAR		
12	86277380	70835	4	SCR, M4.8 X 16 PHTF		
13	86222510	34430	1	PEDAL, THROTTLE		
14	86254970	730304	2	SPRING, COMP 18MM OD X 83 X 2		
15	86222780	620047	2	PLATE, PIVOT		
16	86277360	70833	2	SCR, M6 X 10 PH		
17	86274340	70179	11	SCR, M6 X 16 PH		
18	86224360	730325	2	SPACER 12.7MM ID X 2.78W X 6L		
19	86222810	620050	1	PLATE, COVER		
20	86279140	87085	9	WASHER, M6 SPLIT LOCK DIN127B		
21	86288720	57277	2	NUT, M6 NYLOCK PLATED		
22	86250280	66135	1	POTENTIOMETER, 5K OHMS		
23	86222790	620048	1	PLATE, THROTTLE		
24	86278060	70759	2	SET SCR, M4 X 4MM NP		
25	86224350	730305	1	SPACER, 8MM 16L		
26	86277370	70834	1	SCR, M5 X 30 SHCS		
27	86221850	34433	1	LINK, THROTTLE		
28	86218810	23717	1	HARNESS, TWISTER PEDAL		
29	86136310	57086	1	NUT, M5 HEX		
30	86264920	27049	1	CABLE TIE, 7" UL/CSA		
31	86224750	73993	1	SPRING, COMP, .480D X .91	*(7)	
32	86223260	66085	1	PLUNGER, PLATFORM SWITCH	*(7)	

* SEE SERIAL NUMBER PAGE

PEDAL PLATFORM

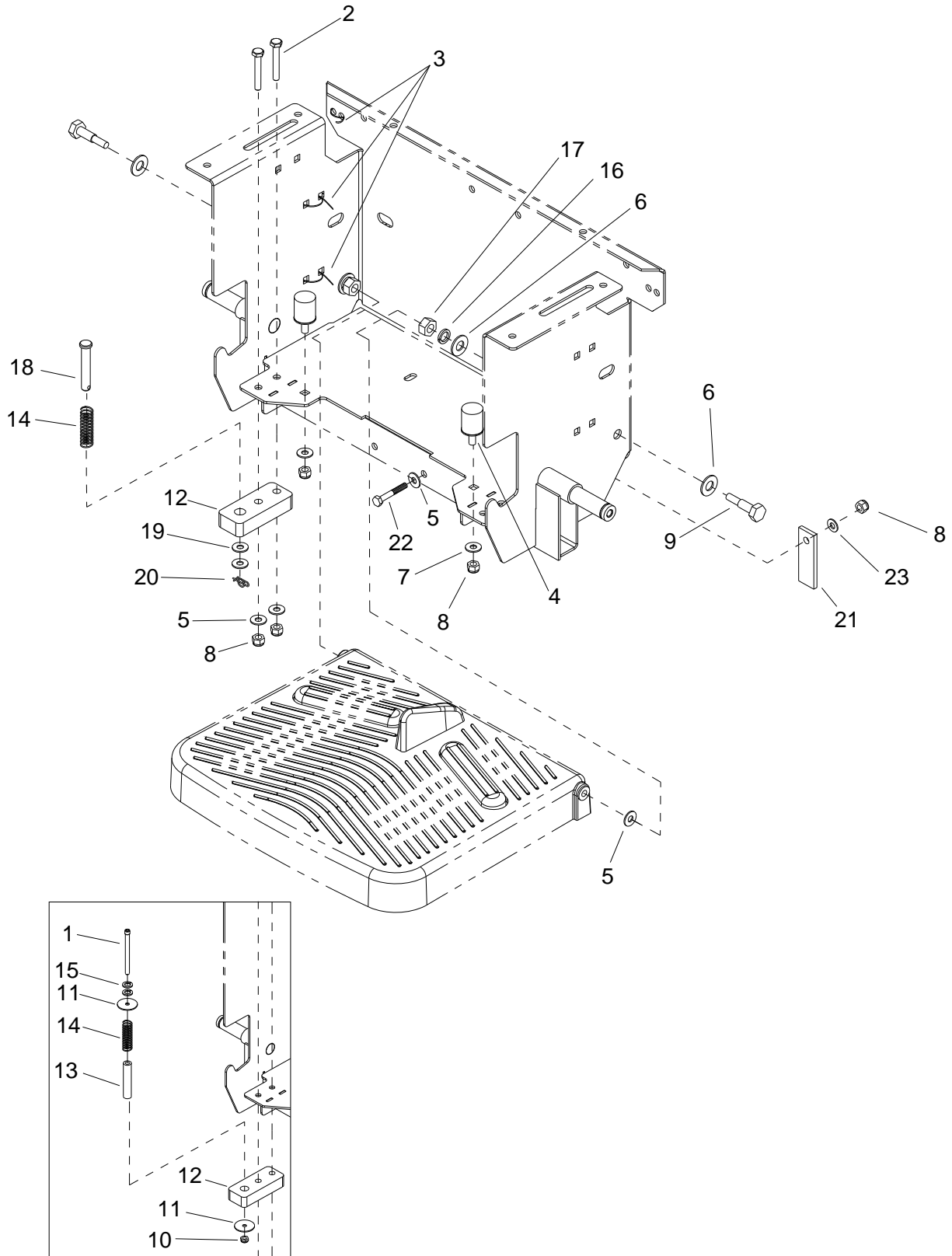

PEDAL PLATFORM

REF	PART NO.	PRV NO.	QTY	DESCRIPTION	SERIAL NO. FROM	NOTES:
1	86277430	70843	1	SCR, 1/4-20 X 3.00 SHCS		
2	86274690	70258	2	SCR, 5/16-18 X 1.5 HHCS GR5PLT		
3	86264920	27049	3	CABLE TIE, 7" UL/CSA		
4	86231070	730328	2	BUMPER, 1 X 1.375 RUBBER		
5	86010670	87029	5	WASHER, 5/16 FLAT SS		
6	86259430	87485	4	M12 FLAT WASHER		
7	86010770	87143	2	WASHER, 7/16ID X1D.08 FLT SS		
8	86270830	57023	5	NUT, 5/16-18 HEX NYLOCK SS		
9	86256470	70852	2	STUB AXLE, M12-1.75 X 45MM		
10	86005810	57245	1	NUT, 1/4-20 HEX NYLOCK SS		
11	86010810	87191	2	WASHER, 1/4" IDX1.0OD FLAT SS		
12	86064480	629993	1	PLATE, SWITCH BASE		
13	86286580	47479	1	SPACER, ACTUATOR SWITCH		
14	86007780	73576	1	SPRING, COMP .60D X2.0L X .045W		
15	86279760	87256	2	WASHER, 1/4 LOCK HICOLLAR PLT		
16	86259440	87486	2	WASHER, M12 SPRING LOCK		
17	86271190	57142	2	NUT, M12 X 1.75 HEX DIN934 PLT		
18	86248920	66487	1	PIN, CLEVIS 1/2 X 2.25	*(7)	
19	86278850	80613	2	WASHER, .506 ID X .94D X .064 NYL	*(7)	
20	86008680	80607	1	COTTER, 1/2" RING	*(7)	
21	86256130	730402	1	STRAP, STATIC, .2T X 1W X 3L		
22	86276980	70775	1	SCR, 5/16 X 2 HHCS SS		
23	86279630	87212	1	WASHER, .344ID X 1.13 OD X .09T PLT		

* SEE SERIAL NUMBER PAGE

REAR COVER

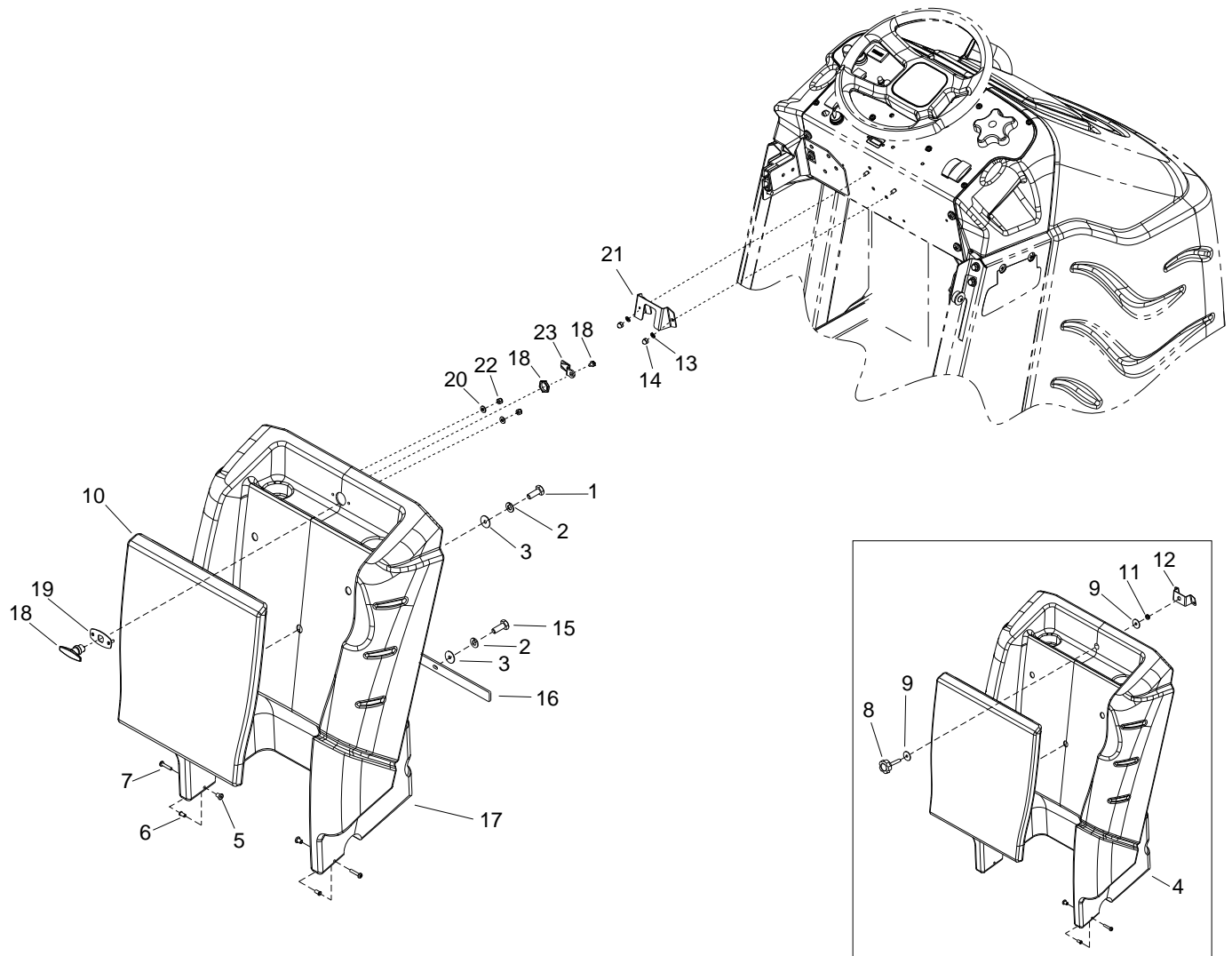

REAR COVER

REF	PART NO.	PRV NO.	QTY	DESCRIPTION	SERIAL NO. FROM	NOTES:
1	86276780	70728	3	SCR, 5/16-18 X 3/4 HHCS SS		
2	86279130	87083	5	WASHER, 5/16 SPLIT LOCK PLTD		
3	86010670	87029	5	WASHER, 5/16 FLAT SS		
4	86062910	270701	1	COVER, REAR, BASIC		
5	86005860	57273	2	NUT, 1/4-20 X 12MM HEX BARREL		
6	86228980	09152	2	BEARING FLANGED .377ID X .505OD		
7	86275870	70556	2	SCR, 1/4-20 X 1.5" PPHMS SS		WAS 70697
8	86242140	72193	1	KNOB, 3/8-16 X 1.5		
9	86010770	87143	2	WASHER, 7/16ID X 1D X .08FLT SS		
10	86248380	66433	1	PAD, FLAT LEANING		
11	86005630	57022	1	NUT, 3/8-16 HEX NYLOCK THIN SS		
12	86071030	140786	1	BRKT, ASSEMBLY, REAR COVER		
13	86010780	87162	2	WASHER, 1/4 SPLIT LOCK		
14	86271940	57299	2	NUT, 1/4-20 ACORN SS		
15	86006560	70083	2	SCR, 5/16-18 X 1 HHCS SS		
16	86066940	140891	1	BAR, COVER		
17	86324660	-	1	REAR COVER, BASIC	*(16)	
18	86324640	-	1	HANDLE, CAM LATCH	*(16)	
19	86324760	-	1	PLATE, COVER LATCH	*(16)	
20	86010630	87013	2	WASHER, 1/4 ID X 5/8 OD SS	*(16)	
21	86324340	-	1	BRKT, REAR COVER	*(16)	
22	86005810	57245	2	NUT, 1/4-20 HEX NYLOCK SS	*(16)	
23	86324650	-	1	PAWL, HANDLE	*(16)	

* SEE SERIAL NUMBER PAGE

SIDE BROOM - DELUXE

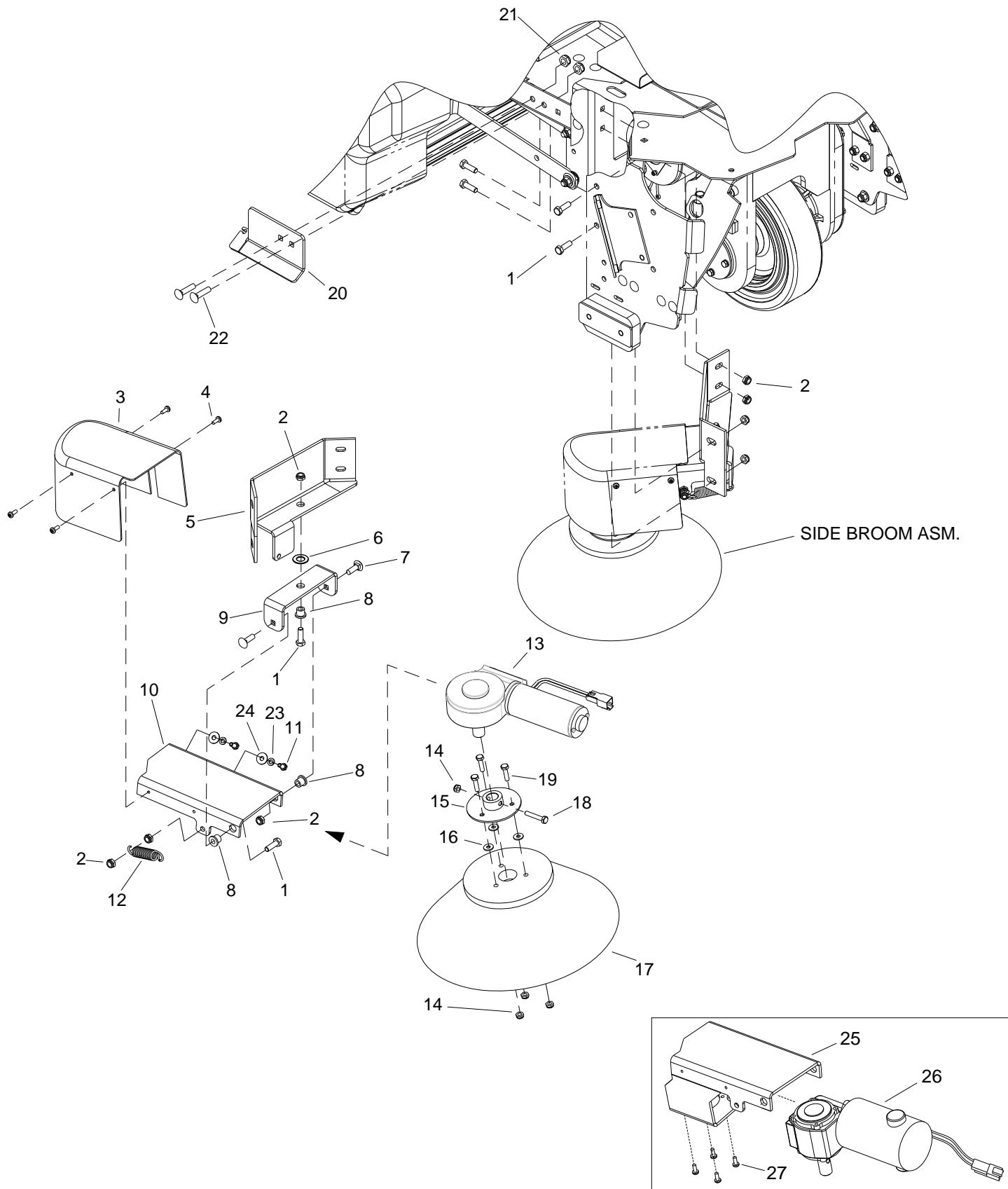

SIDE BROOM – DELUXE

REF	PART NO.	PRV NO.	QTY	DESCRIPTION	SERIAL NO. FROM	NOTES:
1	86006560	70083	7	SCR, 5/16-18 X 1 HHCS SS		
2	86271840	57285	9	NUT, 5/16 –18 HEX NYLOCK THIN SS		
3	86062570	27954	1	COVER, SIDE BROOM		
4	86274350	70187	4	SCR, 10-24 X 1/2 PHTC –F-		
5	86068350	14119	1	BRACKET, MOUNT, SIDE BRUSH		
6	86259410	87206	1	WASHER, THRUST .51 ID X 1 OD X .063		
7	86277130	70795	2	SCR, 5/16-18 X 1.00 CARRIAGE SS		
8	86228840	09124	3	BEARING, FLANGED .314 ID X .502 OD		
9	86088500	14118	1	BRACKET, SWIVEL, SIDE BRUSH		
10	86323530	-	1	ARM, MOUNTING, SIDE BRUSH	*(16)	
11	86274700	70260	2	SCR, M6 X 1 X 16MM HHCS PLT	*(16)	
12	86226830	73268	1	SPRING, EXT .68D X 3.00 L X .098W		
13	86322470	-	1	MOTOR, 36VDC, 90 DEG. 1/16 HP	*(16)	
-	86332020	-	-	BRUSH SET FOR CIM MOTOR 8.632-247.0	*(16)	
14	86271870	57290	4	NUT, 1/4-20 HEX NYLOCK THIN SS		
15	86094090	89282	1	SHAFT, COLLAR ASSEMBLY PLATE		
16	86010630	87013	3	WASHER, 1/4 ID X 5/8 OD SS		
17	86230600	12040	1	BRUSH, 13", NYLON BLACK, SIDE		
18	86273740	70010	1	SCR, 1/4-20 X 1.5 HHCS SS		
19	86273810	70018	3	SCR, 1/4-20 X 1 HHCS SS		
20	86073530	29280	1	BRKT, SIDE BROOM, CABLE MNT	*(8)	
21	86270830	57023	2	NUT, 5/16-18 HEX NYLOCK SS		
22	86276070	70593	2	SCR, 5/16-18 X 3/4 CARRIAGE SS		
23	86279140	87085	2	WASHER, M6 SPLIT LOCK DIN127B	*(16)	
24	86279070	87056	2	WASHER, M6 FLAT	*(16)	
25	86065790	14104	1	ARM - MOUNTING, SIDE BRUSH		
26	86247390	53276	1	MOTOR 36VDC, 90 DEG./16HP		
-	86332030	-		BRUSH SET FOR MOTOR 53276		
27	86002750	70088	4	SCR, 10-32 X 1/2 PPHMS NP		

* SEE SERIAL NUMBER PAGE

**CALL MANUFACTURER FOR SERIAL NUMBER

STEERING

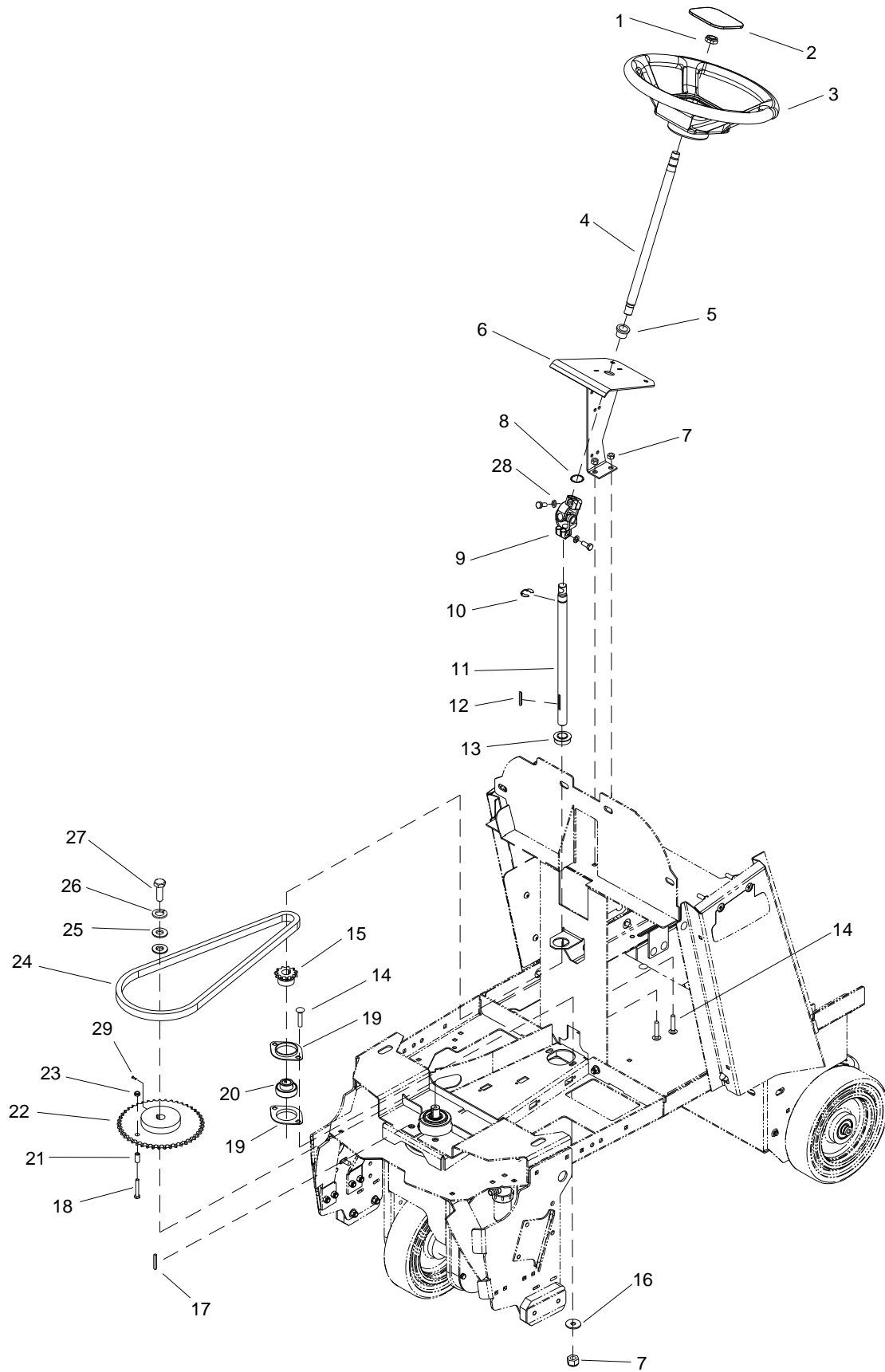

STEERING

REF	PART NO.	PRV NO.	QTY	DESCRIPTION	SERIAL NO. FROM	NOTES:
1	86271610	57228	1	NUT, 5/8-16 HEX NYLOCK THN		
2	86234810	27945	1	COVER, STEERING WHEEL		
3	86259610	730117	1	WHEEL, STEERING 40 SPLINE HUB		
4	86224050	730318	1	SHAFT, UPPER STEERING		
5	86228790	09111	1	BEARING, FLANGE .88ODX.75IDX.75		
6	86091740	140720	1	BRKT, UPPER STEERING		
7	86270830	57023	4	NUT, 5/16-18 HEX NYLOCK SS		
8	86005610	57016	1	NUT, 7/8 DIA PUSHLOCK		
9	86219600	45012	1	JOINT, UNIVERSAL FEMALE		
10	86272900	67416	1	RING, 3/4" KLIP		
11	86224060	730319	1	SHAFT, LOWER STEERING		
12	86219650	48110	1	KEY, 5MM SQ X 39MM L		
13	86228670	09072	1	BEARING, 3/4" BORE FLANGED		
14	86276070	70593	4	SCR, 5/16-18 X 3/4 CARRIAGE SS		
15	86224800	730315	1	SPROCKET, STEERING SHAFT		
16	86010670	87029	2	WASHER, 5/16 FLAT SS		
17	86135970	48045	1	KEY, 3/16 SQ X 5/8 LONG		
18	86275190	70377	1	SCR, 3/8-16 X 1.25 HHCS SS		
19	86008610	80595	2	FLANGE, BEARING PRESS STEEL		
20	86001030	09148	1	BEARING, BALL 3/4 BORE SPHERED		
21	86224320	730221	1	SPACER, .63 OD X .385ID X .64L		
22	86224810	730316	1	SPROCKET, DRIVE WHEEL STEERING		
23	86005630	57022	1	NUT, 3/8-16 HEX NYLOCK THIN SS		
24	86002750	270088	1	CHAIN, ISO 08B, 12.7MM PITCH		
25	86278940	87008	2	WASHER, 1/4 ID X 1-1/4OD PLT		
26	86010780	87162	1	WASHER, 1/4 SPLIT LOCK PLTD		
27	86274330	70175	1	SCR, M6 X 20HHMS PLTD		
28	86279130	87083	2	WASHER, 5/16 SPLIT LOCK PLTD		
29	86253200	70806	1	SET SCR, M6 X 25 NP		SERVICE ONLY
-	86232780	279001	-	CHAIN, MASTERLINK 12.7MM		SERVICE ONLY

VACUUM

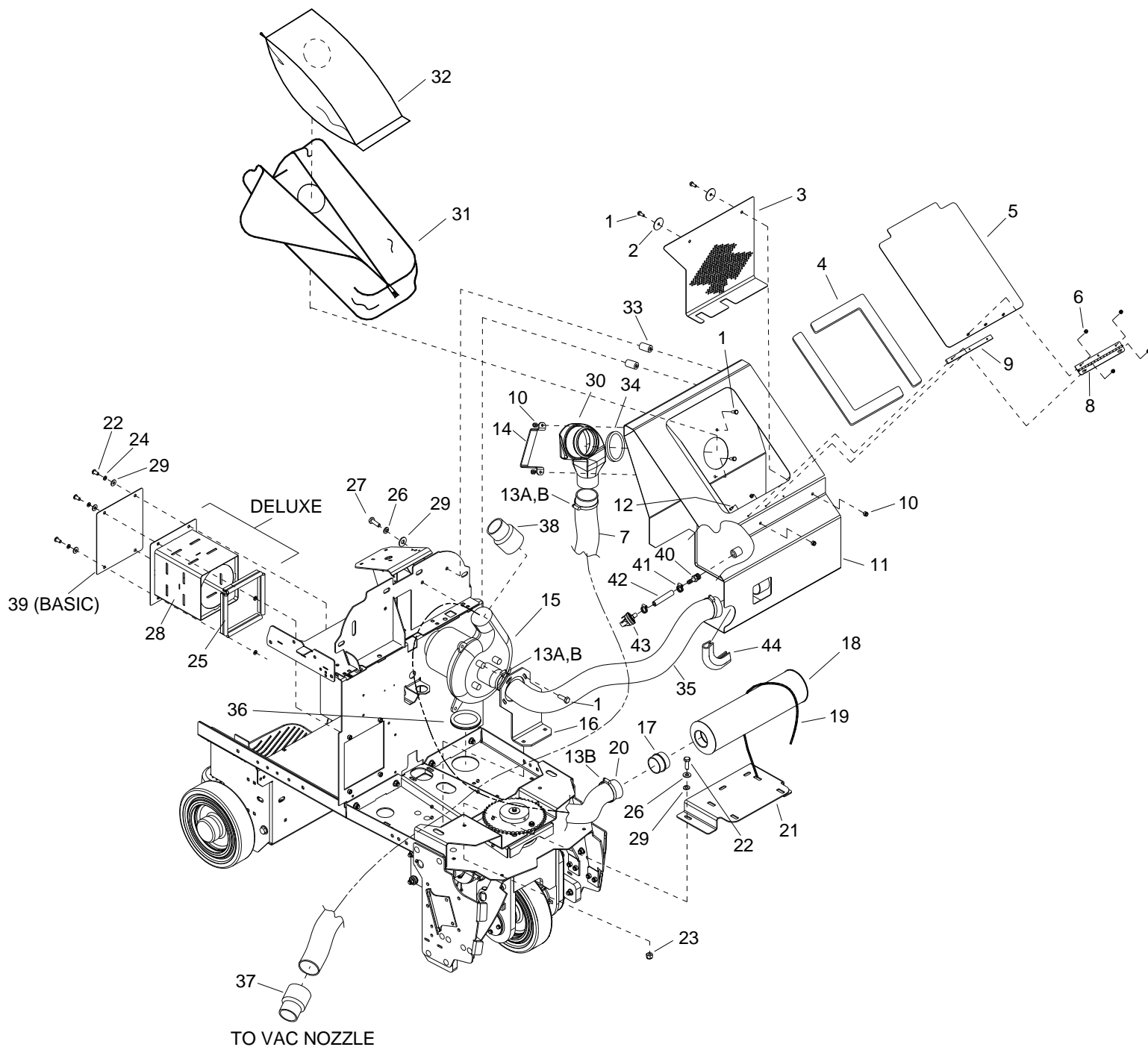

VACUUM

REF	PART NO.	PRV NO.	QTY	DESCRIPTION	SERIAL NO. FROM	NOTES:
1	86273780	70015	8	SCR, 1/4-20 X 3/4 HHCS SS NP		
2	86197220	87193	2	WASHER, 1/4 X 1.5 FENDER PLTD		
3	86086740	730397	1	SCREEN, VAC INTAKE		
4	86237960	35362	2	GASKET, VACUUM BOX LID		
5	86075570	51460	1	COVER, VAC BOX		
6	86272020	57313	5	NUT, 3-32 HEX THIN NYLOCK SS		
7	86240300	39718	1	HOSE, GRY VAC, 2.5 X 36		
8	86200030	41394	1	HINGE, ACCESS PLATE SENSEI		
9	86087370	730398	1	SPACER, VAC BOX LID		
10	86005810	57245	4	NUT, 1/4-20 HEX NYLOCK SS		
11	86229990	140927	1	BOX, WAV VACUUM		
12	86277620	70891	2	SCR, 8-32 X 1/2 HHCS SS		
13A	86233120	20019	3	CLAMP, 2.75" WORM GEAR		BASIC ONLY
13B	86233120	20019	4	CLAMP, 2.75" WORM GEAR		DELUXE ONLY
14	86088130	73950	1	STRAP, CHUTE		
15	86247520	53818	1	VAC MOTOR, 36V 1ST TD		
-	86290210	-	-	BRUSH SET MOTOR 53818		
16	86068440	54208	1	BRACKET, VAC MOTOR MOUNT		
17	86236190	34456	1	FITTING, 2 OD MALE X MALE PVC		DELUXE ONLY
18	86247660	54209	1	MUFFLER, SOUND TUBE PLASTIC		DELUXE ONLY
19	86002830	27196	2	CABLE, TIE, .375 X 24.7		DELUXE ONLY
20	86240760	81399	1	HOSE, 2" VAC X 32"		DELUXE ONLY
21	86068110	14028	1	BRACKET, VAC BOX MOUNT		
22	86276780	70728	6	SCR, 5/16-18 X 3/4 HHCS SS		
23	86270830	57023	2	NUT, 5/16-18 HEX NYLOCK SS		
24	86010780	87162	6	WASHER, 1/4 SPLIT LOCK PLTD		
25	86235400	78600	2	EDGING, 16" GRIP X 5.50" LG		
26	86010670	87029	6	WASHER, 5/16 FLAT SS		
27	86006730	70259	2	SCR, 5/16-18 X 1.75 HHCS PLTD		
28	86075530	27923	1	COVER, VAC MOTOR		DELUXE ONLY
29	86279130	87083	8	WASHER, 5/16 SPLIT LOCK PLTD		
30	86062710	29274	1	DEBRIS CHUTE, WAV		
31	86227870	140915	1	BAG, CLOTH VACUUM		
32	86314620	-	1	BAG, HEPA (PACKAGE OF 5)	*(18)	
-	86215090	140949	1	BAG, PAPER WIDE AREA VAC		OPTION
33	86224380	730336	2	SPACER, 1 OD X .391 ID X 1.063		
34	86238050	36246	1	GASKET, 4.25OD X 3.63ID X .25		
35	86240310	39719	1	HOSE, GRAY VAC, 2.25 X 10.0		WAS 39419
36	86238450	36245	1	GROMMET, 3.0 ID X 3.25 GROOVE		
37	86234890	270148	1	CUFF, 2.5 SLIP X 2.5 HOSE		
38	86009380	81866	1	CUFF, 2" ID VAC-U-FLEX HOSE		
39	86081230	62708	1	PLATE, VAC COVER		BASIC ONLY
40	86198000	40067	1	HOSEBARB, 1/8MPT X 3/8 PLASTIC		
41	86281680	39486	1	HOSE, 3/8ID NYLOBRAID X 2"		
42	86233090	20016	2	CLAMP, 1/4 ID HOSE		
43	86257160	72199	1	SWITCH, VACUUM 15" H20 NC/NO		
44	86251750	67602	1	RISER, BUMPER		
-	86316200	-	-	VACUUM LINT BRUSH		NOT SHOWN

* SEE SERIAL NUMBER PAGE.

WHEEL-FRONT DRIVE-CHAIN

REF	PART NO.	PRV NO.	QTY	DESCRIPTION	SERIAL NO. FROM	NOTES:
1	86223980	09134	4	SEALED BALL BRNG, 25MM X 52MM		
2	86223480	67450	2	RING, 52MM INTERNAL SNAP		
3	86219420	41510	1	STEERING, HUB		
4	86224040	730306	1	SHAFT, ASM, DRIVE PIVOT		
5	86005510	53810	1	MOTOR, 36V 180RPM GEAR		
-	86216210	53820	-	BRUSH SET MOTOR 53810		
-	86227440	05261	-	ARMATURE 53810 MOTOR		
6	86136360	57275	1	NUT, M10X1.5 HEX NYLOCK PLTD		
7	86010720	87086	1	WASHER, M10 X 30 PLTD		
8	86222730	620038	1	PLATE, DRIVE WHEEL YOKE LH		
9	86318830	-	11	SCR, M10 X 30 SHCS		
10	86275640	70515	4	SCR, 3/8-24 X 3/4 HHCS GR5 PLTD		
11	86279700	87244	5	WASHER, M10 X 18 FLAT		
12	86219620	48106	1	KEY, 1/4 SQ. X .63		
13	86007620	730310	1	SPROCKET, MOTOR SHAFT		
14	86279710	87245	3	WASHER, M8 (2 THK X 26 OD) FLAT		
15	86136640	70262	2	SCR, M8-1.25 X 20HHMS PLTD		
16	86222710	620036	1	PLATE, CHAIN COVER		
17	86279690	87243	12	WASHER, M6 SPLIT LOCK BLK		
18	86277340	70830	12	SCR, M6 X 15 HHCS BLK		
19	86002730	270085	1	CHAIN, ISO 08B 12.7MM PITCH/LINK		
-	86232770	279000	-	CHAIN, OFF-SET LINK 12.7MM		SERVICE ONLY
-	86232780	279001	-	CHAIN, MASTERLINK 12.7MM		SERVICE ONLY
20	86222760	620041	1	PLATE, DRIVE YOKE RH		
21	86007630	730311	1	SPROCKET, DRIVE WHEEL		
22	86002710	270076	1	CHAIN TENSIONER		
23	86224270	730293	1	SLEEVE, CHAIN TENSIONER		
24	86277330	70829	1	SCR, M10 X 45 HHCS		
25	86222720	620037	1	PLATE, BEARING RETAINER		
26	86224330	730294	1	SPACER, 25.5ID X 45OD X 65L		
27	86219630	48107	1	KEY, 3/16 SQ X .67		
28	86000850	05231	1	AXLE, DRIVE		
29	86219640	48108	1	KEY, 1/4 SQ X 1.5		
30	86259940	89275	1	WHEEL, 10X2.5 W/KEYWY GRY, NT		
31	86222750	620040	1	PLATE, DRIVE YOKE FRONT		
32	86224340	730295	1	SPACER, 25.5ID X 45OD X 43L		
33	86222770	620042	1	PLATE, BEARING COVER		
34	86217720	29269	-	DRIVE ASM, MOTOR		COMPLETE
35	86311040	-	1	SPACER, CHAIN DRIVE AXLE		
36	86277320	70828	1	SCR, M10 X 30 HHCS		

WHEEL-FRONT DRIVE, GEAR

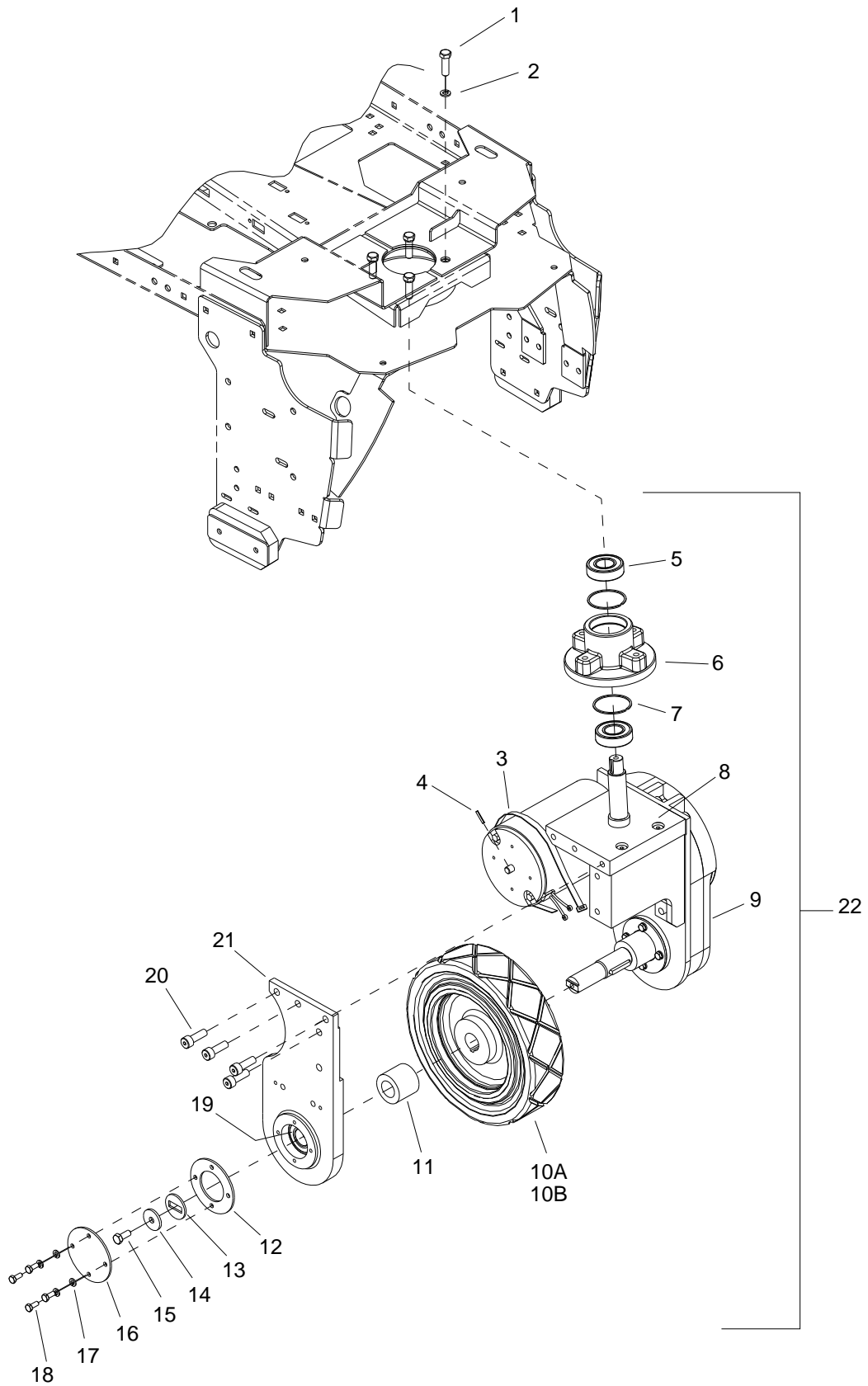

WHEEL-FRONT DRIVE, GEAR

REF	PART NO.	PRV NO.	QTY	DESCRIPTION	SERIAL NO. FROM	NOTES:
1	86275190	70377	4	SCR, 3/8-16 X 1.25 HHCS SS		
2	86010790	87163	4	WASHER, 3/8 SPLIT LOCK PLTD		
3	86002830	27196	1	CABLE TIE, .375 X 24.7		
4	86006170	66031	1	PIN, ROLL 1/8" X 3/4"L		
5	86223980	09134	3	SEALED BALL BRNG, 25MM X 52MM		
6	86219420	41510	1	HUB STEERING		
7	86223480	67450	2	RING, 52MM INTERNAL SNAP		
8	86224020	730233	1	SHAFT ASM, DRIVE PIVOT		
9	86317190	-	1	DRIVE MOTOR ASSEMBLY HELICAL		
10A	86011120	89262	1	WHEEL, 10 X 2, 5 X 1.06 W/KEYWAY		
10B	86259920	89273	1	WHEEL, 10 X 2. 5 W/KEYWAY, GRY		OPTION
11	86224440	730387	1	SPACER, 25.51 ID X 45 OD X 39.1 L		
12	86222720	620037	1	PLATE, BEARING RETAINERX		
13	86225810	87506	1	WASHER, ANTI-ROTATION		
14	86279710	87245	1	WASHER, M8 (2THK X 26 OD)		
15	86136640	70262	1	SCR, M8-1.25 X 20 HHMS PLTD		
16	86222770	620042	1	PLATE, BEARING COVER		
17	86279690	87243	4	WASHER, M6 SPLIT LOCK BLK		
18	86277340	70830	4	SCR, M6 X 15 HHCS BLK		
19	86223980	09134	3	SEALED BALL BRNG, .25MM X 52MM		
20	86318830	-	10	SCR, M10 X 30 SHCS		
21	86222760	620041	1	PLATE, DRIVE YOKE RH		
22	86317200	-	1	GEAR BOX DRIVE UNIT HELICAL		WHEEL NOT INCLUDED
-	86216210	53820	-	BRUSH SET MOTOR, 53810 86005510		

* SEE SERIAL NUMBER PAGE

WHEEL-FRONT BRAKE

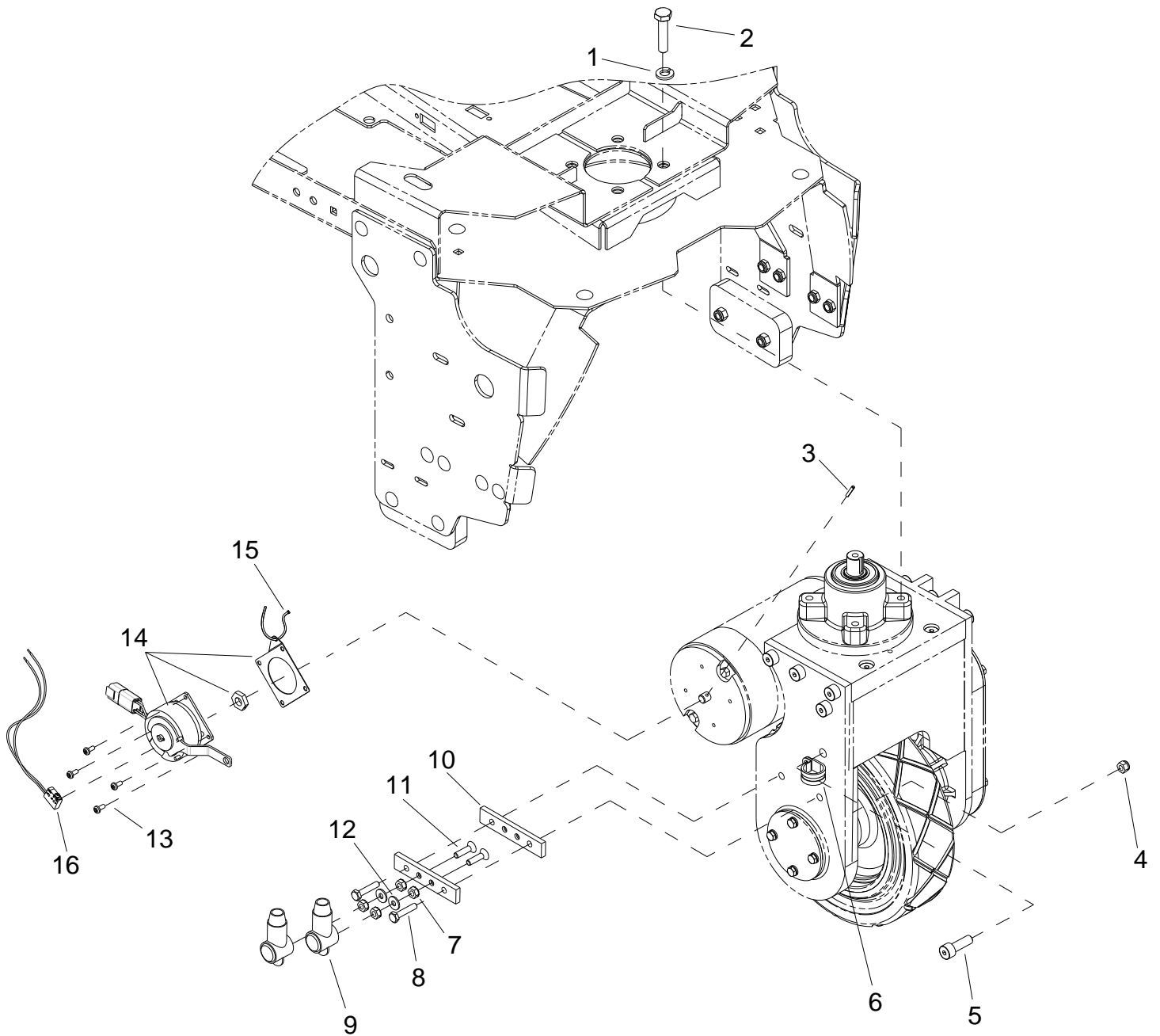

WHEEL-FRONT BRAKE

REF	PART NO.	PRV NO.	QTY	DESCRIPTION	SERIAL NO. FROM	NOTES:
1	86010790	87163	4	WASHER, 3/8 SPLIT LOCK PLTD		
2	86275190	70377	4	SCR, 3/8-16 X 1.25 HHCS SS		
3	86006170	66031	1	PIN, ROLL 1/8" X 3/4"L SS		
4	86005810	57245	2	NUT, 1/4-20 HEX NYLOCK SS		
5	86318830	-	1	SCR, M10 X 30 SHCS		
6	86233410	81270	1	CLAMP, 3/4 DIA CUSHION .406DIA		
7	86005710	57105	4	NUT, 1/4-20 HEX W/STAR WASHER		
8	86273740	70010	2	SCR, 1/4-20 X 1.50 HHCS		
9	86008920	80889	2	BOOT, RUBBER TERM. ISOLATOR		
10	86257490	76155	2	TERMINAL MOUNT		
11	86006840	70390	2	SCR, 1/4-20 X 1 FHCS PLTD		
12	86010630	87013	2	WASHER, 1/4 ID X 5/8 OD SS		
13	86273340	00-000289	4	SCR, 8-32 X 3/8 SHCS SS		
14	86001740	140816	1	BRAKE, 36VDC W/CONNECTOR		
15	86264930	27050	1	CABLE TIE, 3.5" UL/CSA		
16	86320870	-	1	SWITCH, 36V BRAKE		

WHEEL-REAR

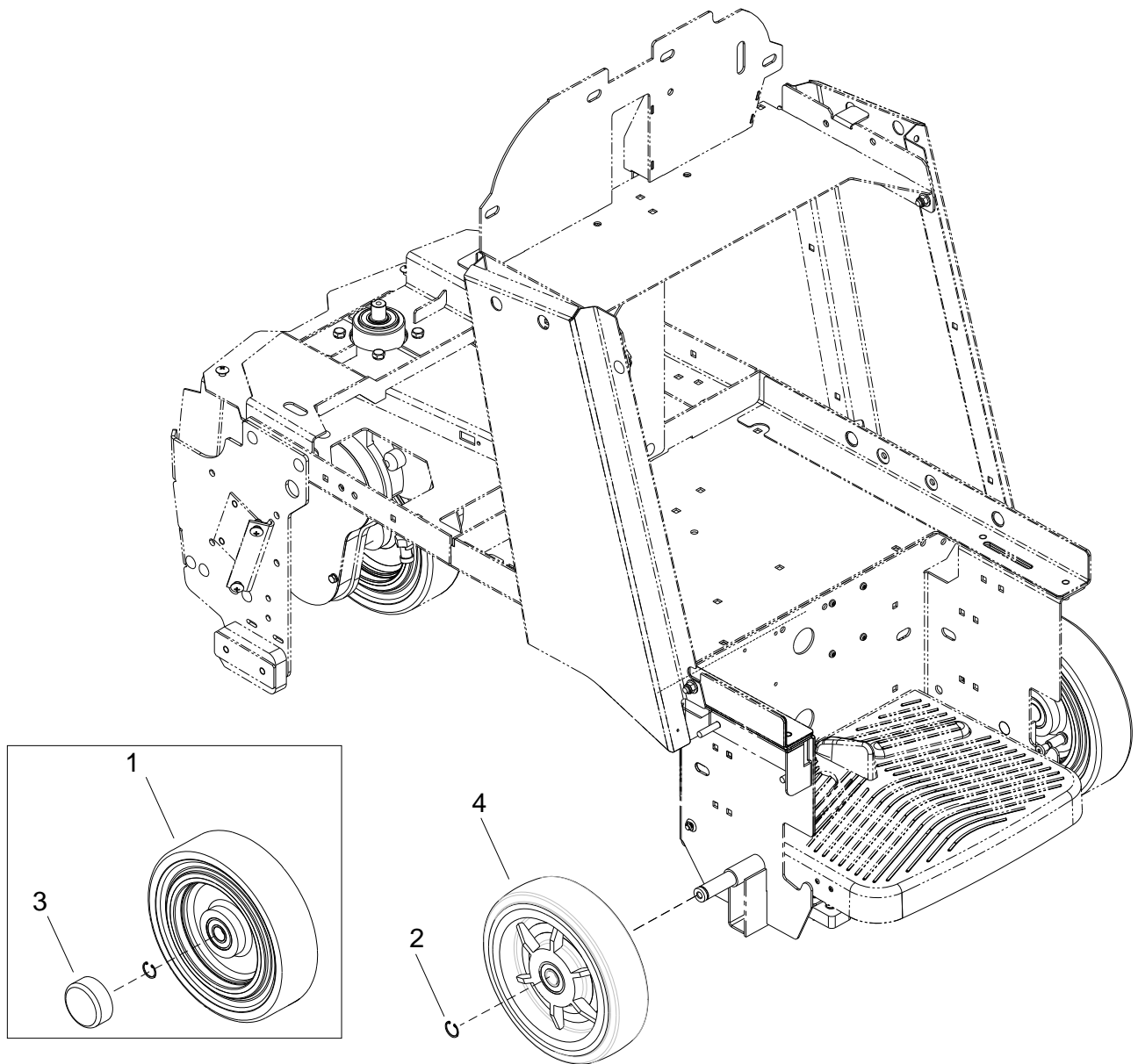

WHEEL-REAR

REF	PART NO.	PRV NO.	QTY	DESCRIPTION	SERIAL NO. FROM	NOTES:
1	86259950	89276	2	WHEEL, 10X2.5 W/BRNGS, GRY, NT		
2	86008710	80623	2	RING, 3/4" EXT SNAP H-D		
3	86232130	17309	2	CAP, 2.75 ID X 1.0 L BLK VINYL		
4	86322590	-	2	WHEEL, 10X2.5 W/BRNGS, GRY, NT	*(14)	

*SEE SERIAL NUMBER PAGE

** CALL MANUFACTURER FOR SERIAL NUMBER

WIRING-BATTERIES

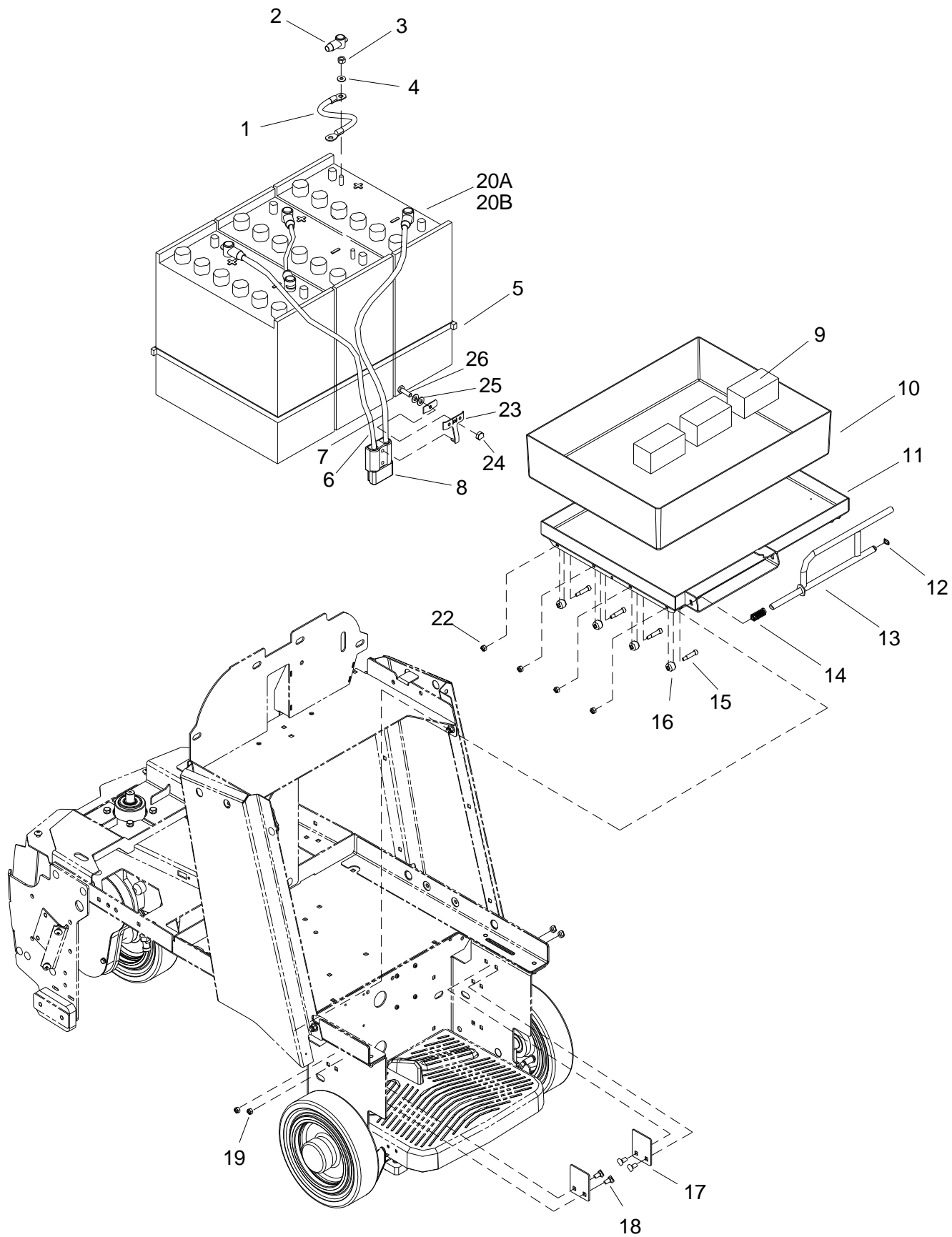

WIRING-BATTERIES

REF	PART NO.	PRV NO.	QTY	DESCRIPTION	SERIAL NO. FROM	NOTES:
1A	86260200	80872	2	WIRE, 4X14.5BK 3/8 RING X 3/8 RING		
1B	86002510	23125	2	CABLE ASM, BAT. JUMPER X 15"		
2	86008920	80889	6	BOOT, RUBBER TERM. ISOLATOR		
3	86271910	57295	6	NUT, 5/16-18 FLEXLOCK		
4	86010670	87029	6	WASHER, 5/16 FLAT SS		
5	86264960	27915	2	CABLE TIE, .375 X 43"		
6A	86260610	880836	1	WIRE, 4X25RD CTERM X 3/8RING	*(10)	
6B	86002570	23190	1	WIRE, 4X27 RD BCLAMP X CTERM		
7A	86260230	80876	1	WIRE, 4X30 BK CTERM X 3/8RING		
7B	86002580	23191	1	WIRE, 4X27 BK BCLAMP X CTERM		
8	86008760	80682	1	CONN, 175 DCA GRY W/O TERMS		
9	86229700	08071	3	BLOCK, 3.0 X 1.5 X 1.5		
10	86008300	78242	1	TRAY, BATTERY LINER		
11	86008410	78568	1	TRAY, BATTERY		
12	86272810	67132	1	RING, 1/2 EXT. SNAP H-D		
13	86092910	51396	1	LATCH ROD, BATTERY TRAY		
14	86254990	730313	1	SPRING, COMP, 63ODX3.5LX.047		
15	86278150	70117	8	SHOULDER BOLT, 5/16 OD X 1.0 L		
16	86259910	89265	8	WHEEL, BATTERY TRAY		
17	86088790	78571	2	TRAY, STANDARD STOP		
18	86276070	70593	4	SCR, 5/16-18 X 3/4 CARRIAGE SS		
19	86270830	57023	4	NUT, 5/16-18 HEX NYLOCK SS		
20A	86228410	10023	3	BATTERY, 12V, 205AH		
20B	86283410	10030	3	BATTERY, 12V, 225AH		
21	86284090	02456	1	CHARGER, 36V, 20A, 115V, C175		NOT SHOWN
22	86005810	57245	8	NUT, 1/4-20 HEX NYLOCK SS		
23	86233360	28038	1	CLAMP, CABLE KIT SY945		
24	86270890	57034	1	NUT, ACORN 10-32		
25	86010650	87018	1	WASHER, #10 X 9/16 OD		
26	86273980	70066	1	SCREW, 10-32 X 3/4 PPHMS SS		

* SEE SERIAL NUMBER PAGE

WIRING-COMPONENTS

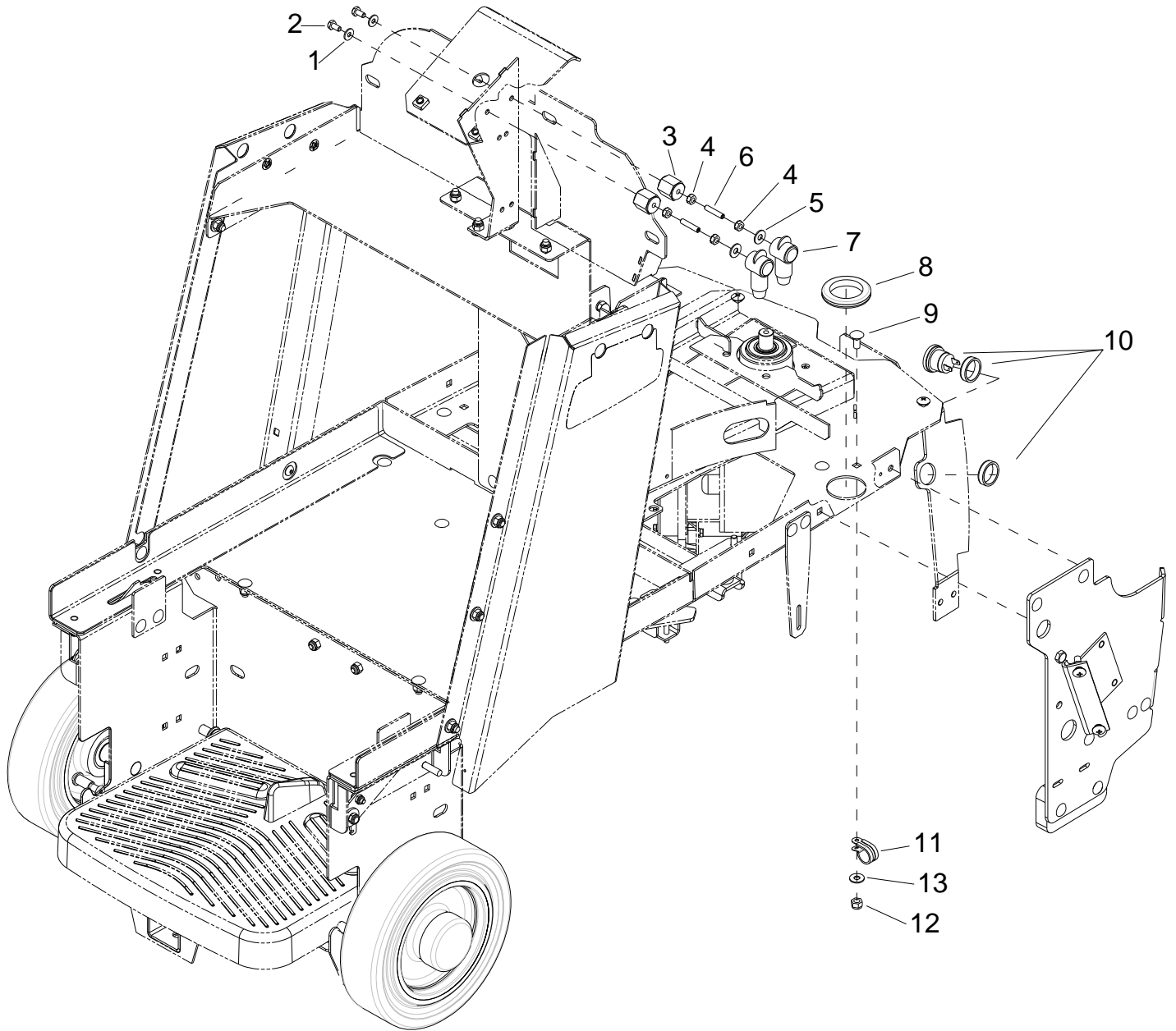

WIRING-COMPONENTS

REF	PART NO.	PRV NO.	QTY	DESCRIPTION	SERIAL NO. FROM	NOTES:
1	86010780	87162	2	WASHER, 1/4 SPLIT LOCK PLTD		
2	86273830	70020	2	SCR, 1/4-20 X 1/2 HHCS SS NP		
3	86255910	73659	2	STANDOFF, 1/4-20 X 1.0 HEX INS		
4	86005710	57105	4	NUT, 1/4-20 HEX W/STAR WASHER		
5	86010630	87013	2	WASHER, 1/4 ID X 5/8 OD SS		
6	86006850	70393	2	SET SCR, 1/4-20 1.25L		
7	86008920	80889	2	BOOT, RUBBER TERM. ISOLATOR		
8	86238500	81427	2	GROMMET, 1.703IDX2.5ODX.125GRV		
9	86276070	70593	1	SCR, 5/16-18 X 3/4 CARRIAGE SS		
10	86239720	41520	1	HORN, 108DB MINIATURE PIEZO		
11	86233410	81270	1	CLAMP, 3/4 DIA CUSHION .406DIA		
12	86270830	57023	1	NUT, 5/16-18 HEX NYLOCK SS		
13	86010670	87029	1	WASHER, 5/16 FLAT SS		

WIRING-CONTROL PANEL

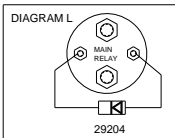
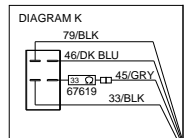
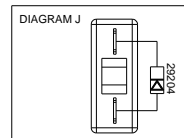
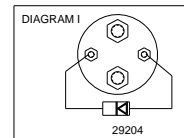
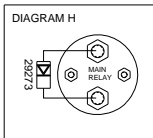
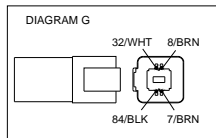
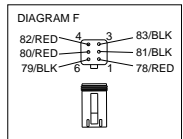
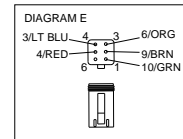
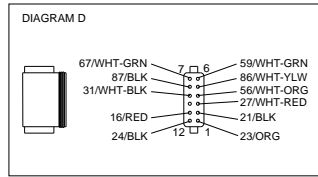
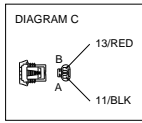
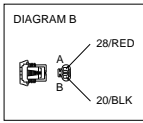
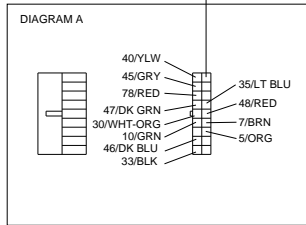
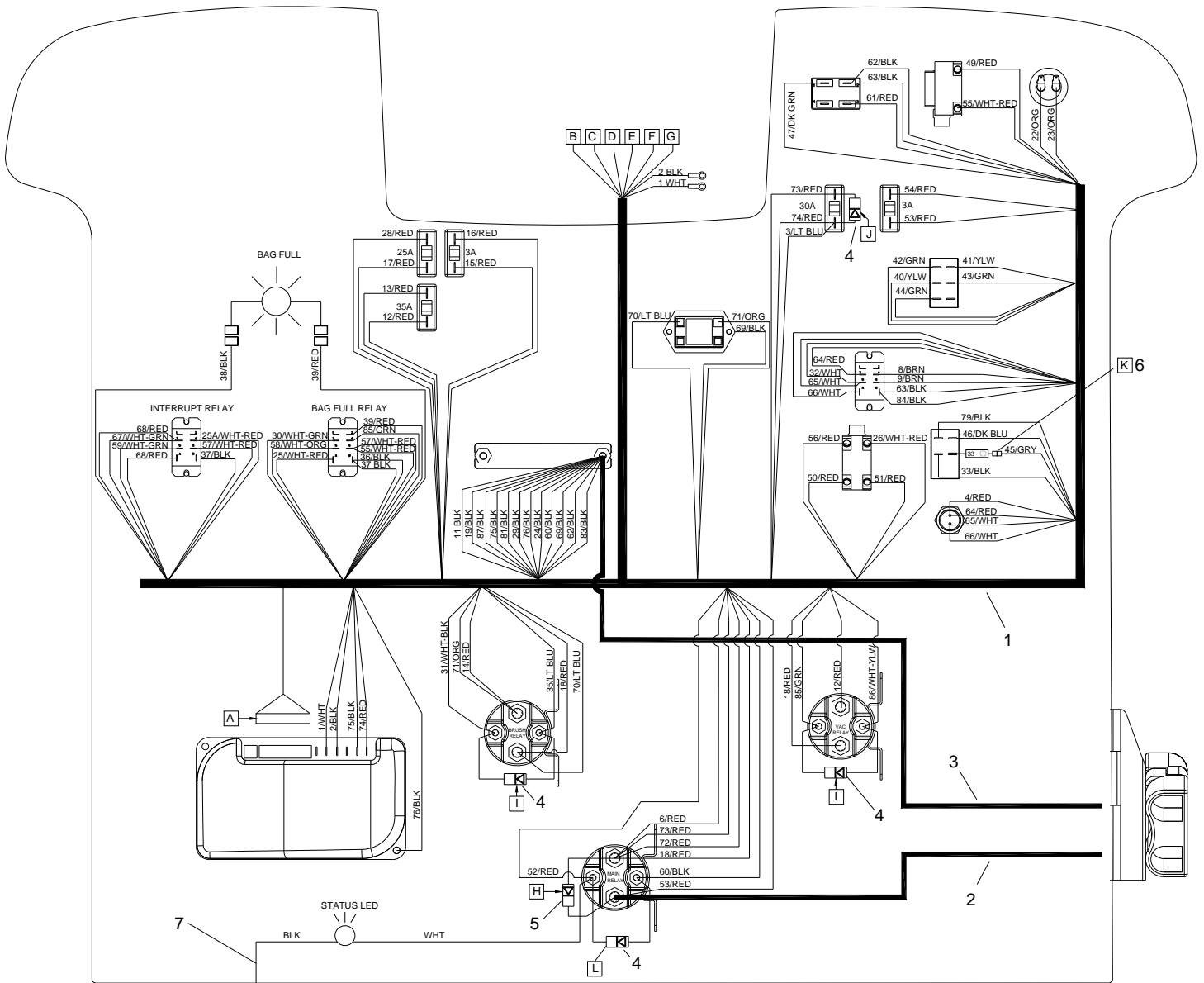

WIRING-CONTROL PANEL

REF	PART NO.	PRV NO.	QTY	DESCRIPTION	SERIAL NO. FROM	NOTES:
1	86239230	41550	1	HARNESS, CONTROL PANEL		
2	86260540	880426	1	WIRE, 4X13 RD C.TERM X 5/16RING		
3	86010860	880353	1	WIRE, 4X20 BL CTERM X5/16RING		
4	86261210	29204	4	DIODE ASM, 76008, 79008		
5	86261250	29273	1	DIODE ASM, FAST RECOVERY		
6	86251490	67619	1	RESISTOR ASM, 1/2 WATT 33 OHM	*(11)	
7	86311210	-	1	LIGHT ASM, INDICATOR, CODE		

* SEE SERIAL NUMBER PAGE

WIRING-DRIVE MOTOR

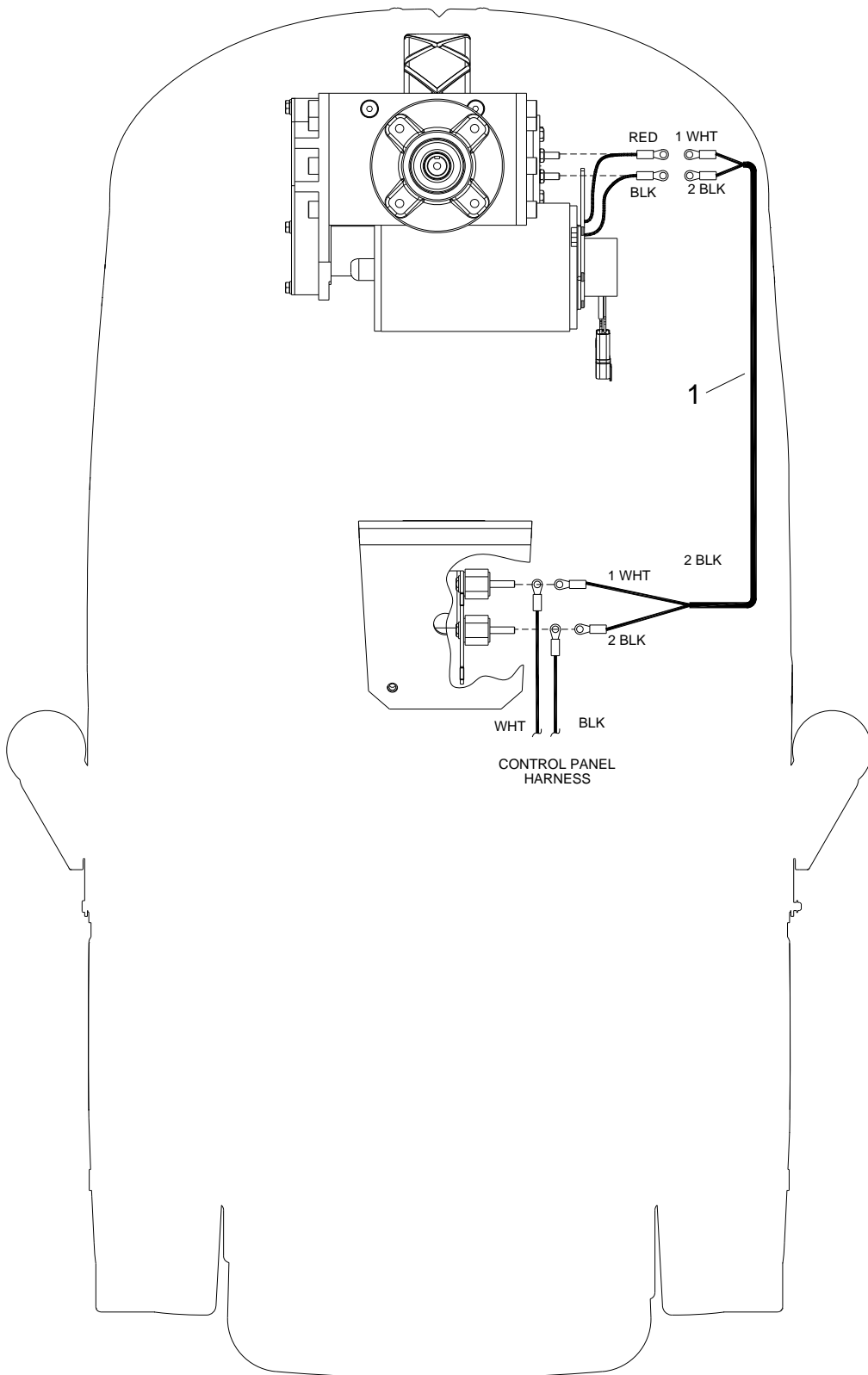

WIRING-DRIVE MOTOR

REF	PART NO.	PRV NO.	QTY	DESCRIPTION	SERIAL NO. FROM	NOTES:
1	86239120	41522	1	HARNESS, CHARIOT PROPEL		

WIRING-MAIN HARNESS

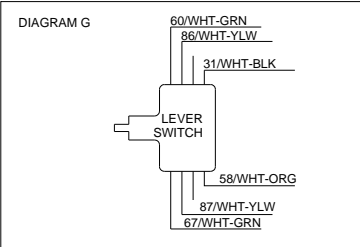
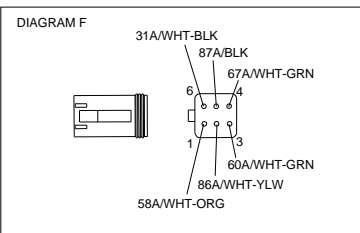
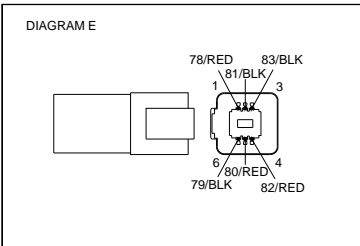
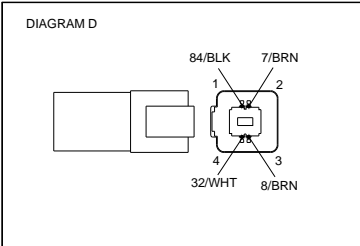
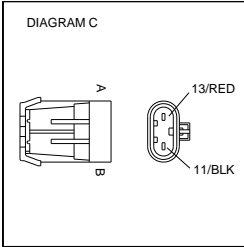
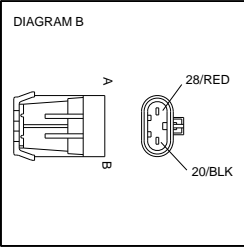
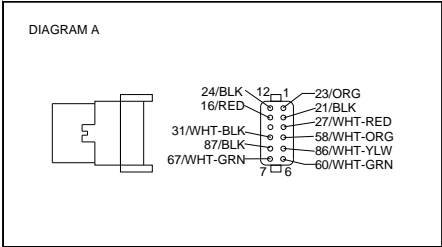
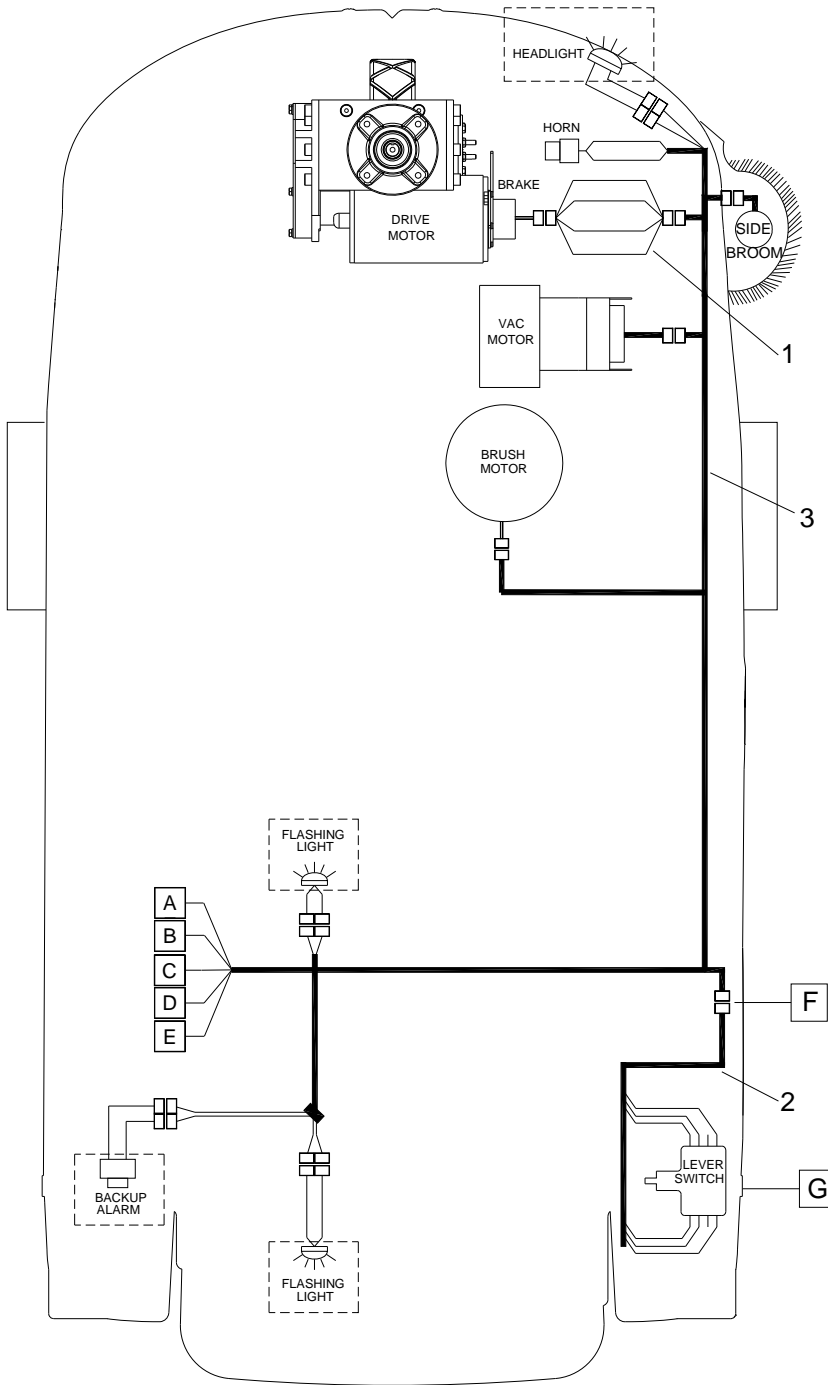

--- DENOTES OPTIONAL EQUIPMENT

WIRING-MAIN HARNESS

REF	PART NO.	PRV NO.	QTY	DESCRIPTION	SERIAL NO. FROM	NOTES:
1	86239170	41528	1	HARNESS, BRAKE		
2	86239240	41552	1	HARNESS, LEVER SWITCH		
3	86239220	41549	1	HARNESS, I VAC, MAIN		

WIRING-PEDAL PLATFORM-From Serial Number (17*)

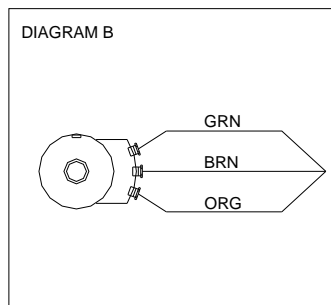
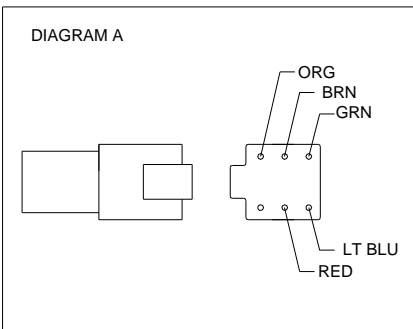
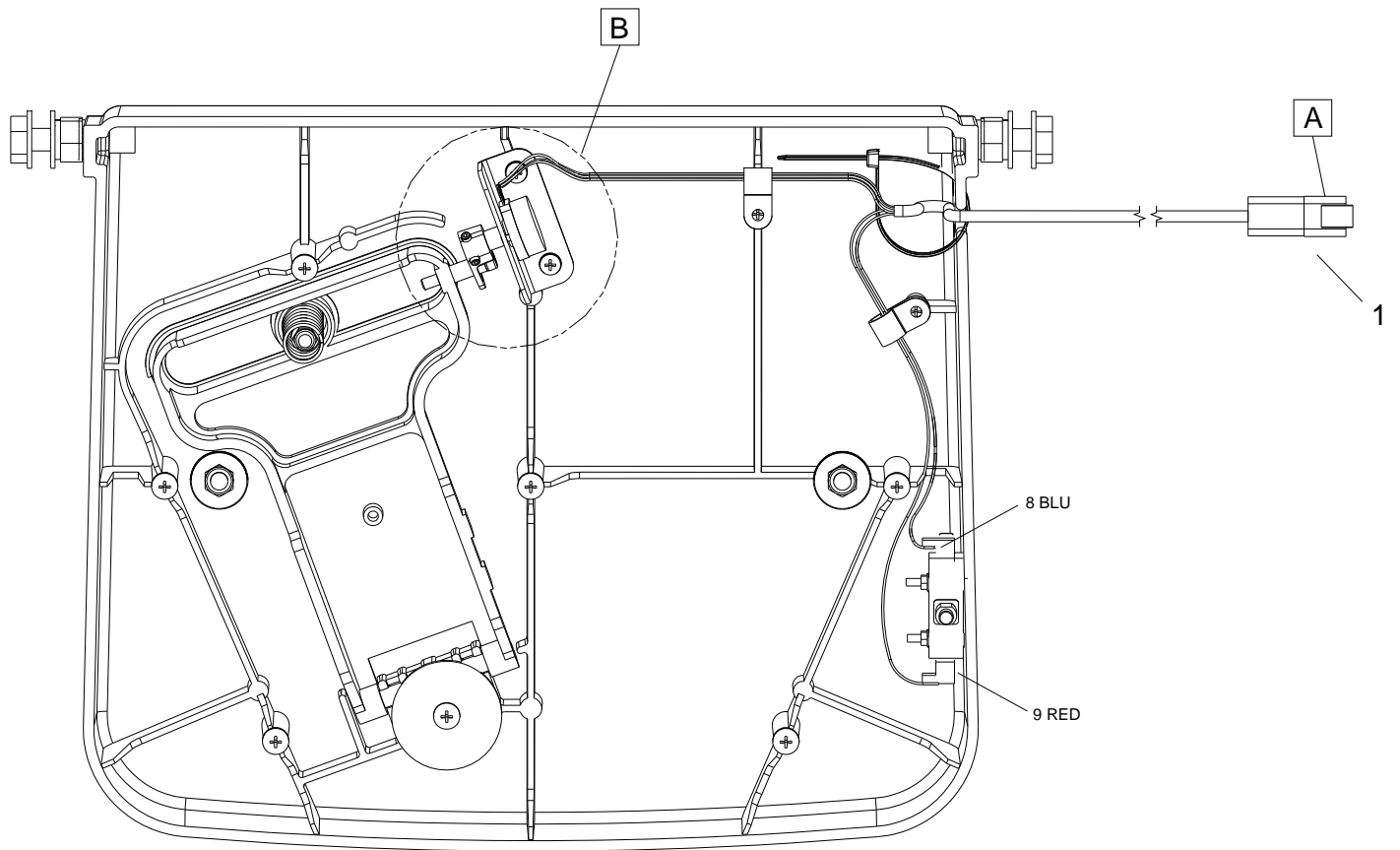

WIRING-PEDAL PLATFORM-From Serial Number (17*)

REF	PART NO.	PRV NO.	QTY	DESCRIPTION	SERIAL NO. FROM	NOTES:
1	86315100	-	1	HARNESS, PEDAL		

***See Serial Number page.**

WIRING-PEDAL PLATFORM-To Serial Number (17*)

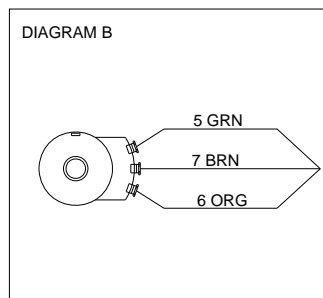
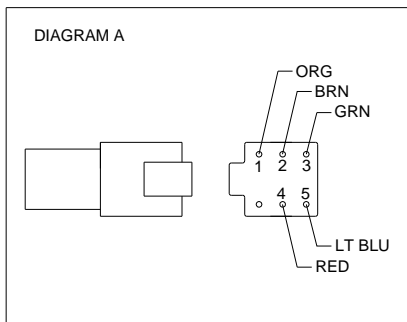
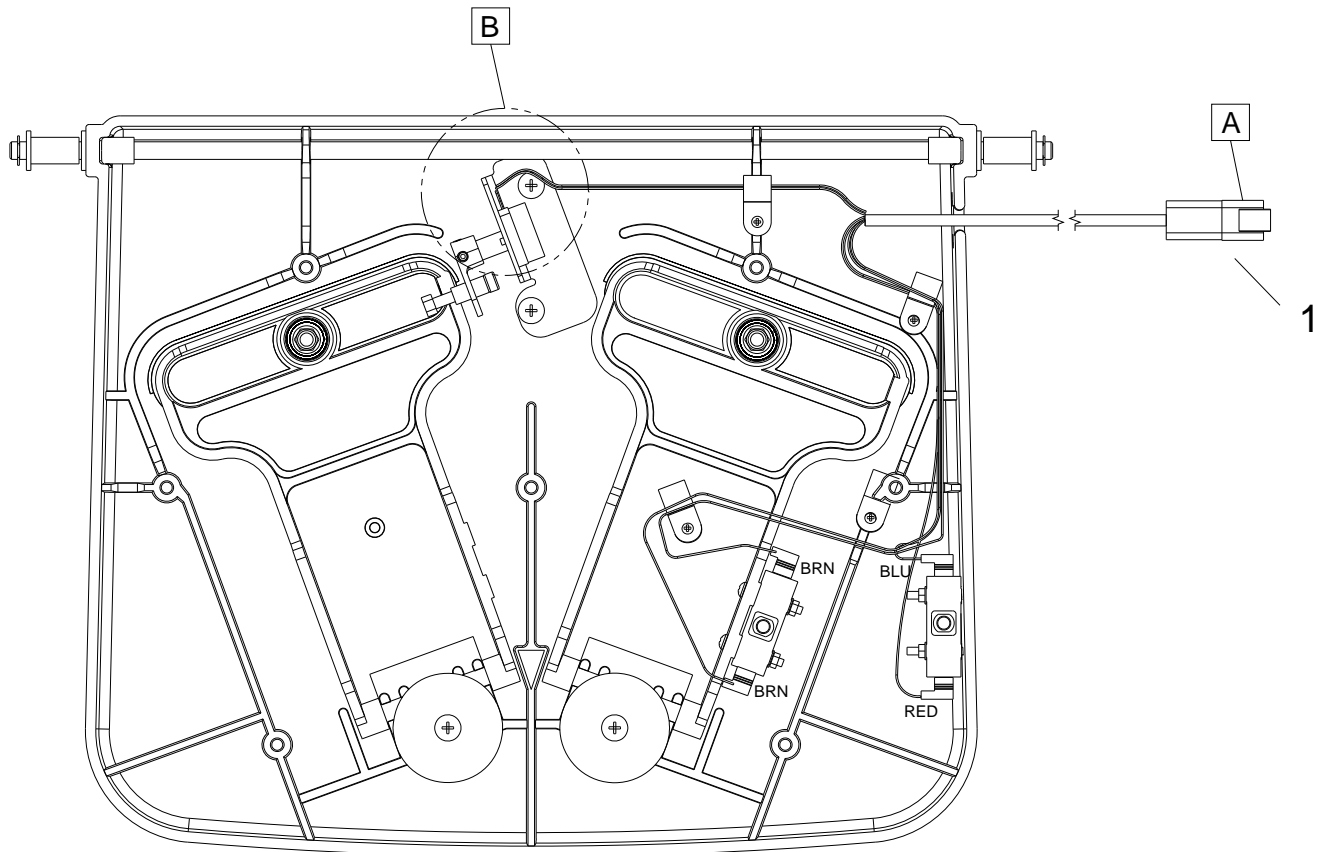

WIRING-PEDAL PLATFORM-To Serial Number *(17*)

REF	PART NO.	PRV NO.	QTY	DESCRIPTION	SERIAL NO. FROM	NOTES:
1	86218810	23717	1	HARNESS, TWISTER PEDAL		

***See Serial Number page.**

WIRING DIAGRAM

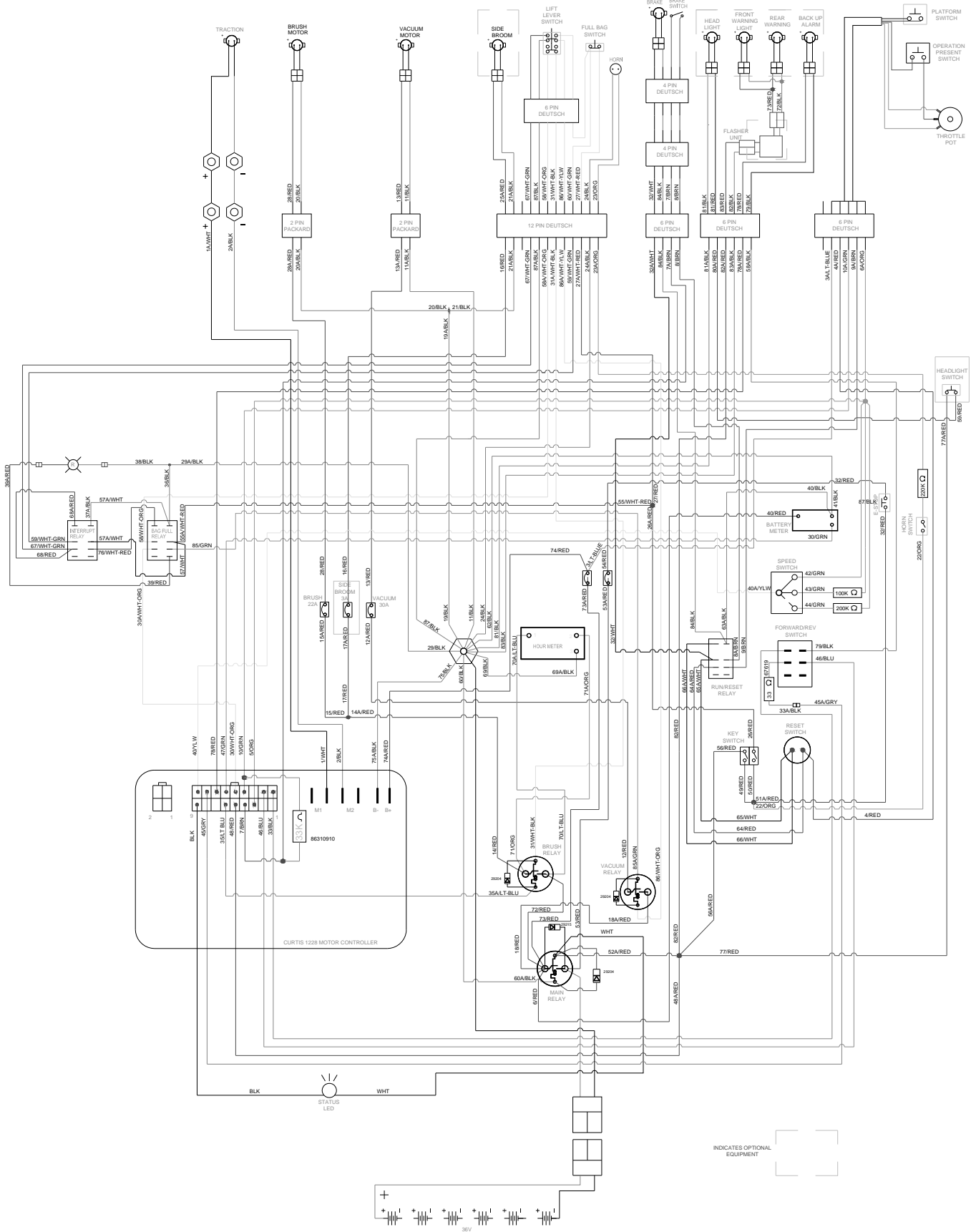

SUGGESTED SPARE PARTS

REF	PART NO.	PRV NO.	DESCRIPTION	SERIAL NO. FROM	NOTES:
1	86001910	14606	BREAKER, 30A 50VDC CIRCUIT		
2	86002000	14717	BREAKER, 3 AMP 1681-090-300		
3	86002010	14942	BOOT, 3/8 CIRCUIT BREAKER		
4	86232130	17309	CAP, 2.75 ID X 1.0 L BLACK VINYL		
5	86004860	48073	KEY, SWITCH		
6	86251410	67506	RELAY, 15A 36V MINI		
7	86007140	72130	SWITCH, SPST 2-POSITION ROCKER		
8	86007190	72161	SWITCH, DPST KEY		
9	86001740	140816	BRAKE, 36 VDC W/CONNECTOR		
10	86002730	270085	CHAIN, ISO 08B 12.7 MM PITCH		
11	86332010	-	BRUSH SET FOR MOTOR 53275		
12	86332020	-	BRUSH SET FOR CIM MOTOR 8.632-247.0	*(16)	
13	86332030	-	BRUSH SET FOR MOTOR 53276		

BACK-UP ALARM - OPTION

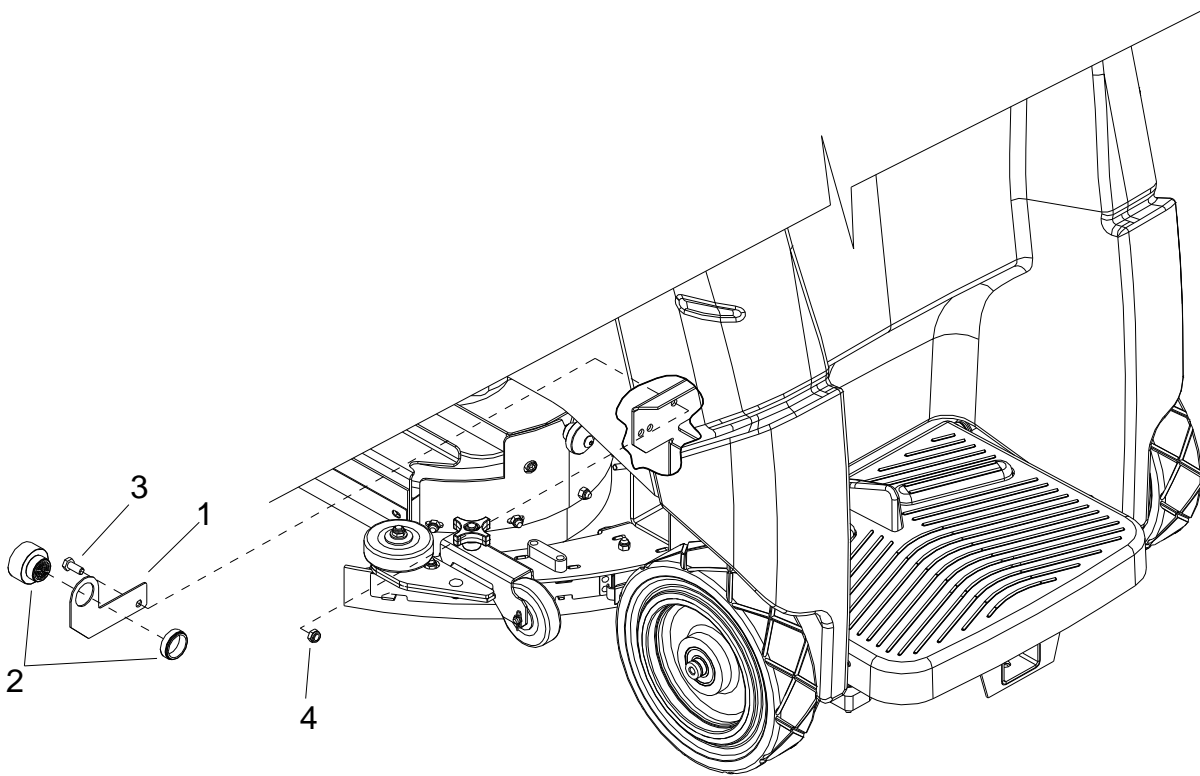

BACK-UP ALARM - OPTION

REF	PART NO.	PRV NO.	QTY	DESCRIPTION	SERIAL NO. FROM	NOTES:
1	86071140	140817	1	BRKT, BACK UP ALARM		
2	86231500	80882	1	BUZZER, PIEZO 6-28VCD		
3	86276780	70728	1	SCR, 5/16-18 X 3/4 HHCS SS		
4	86271840	57285	1	NUT, 5/16-18 HEX NYLOCK THIN SS		

BATTERY CART - OPTION

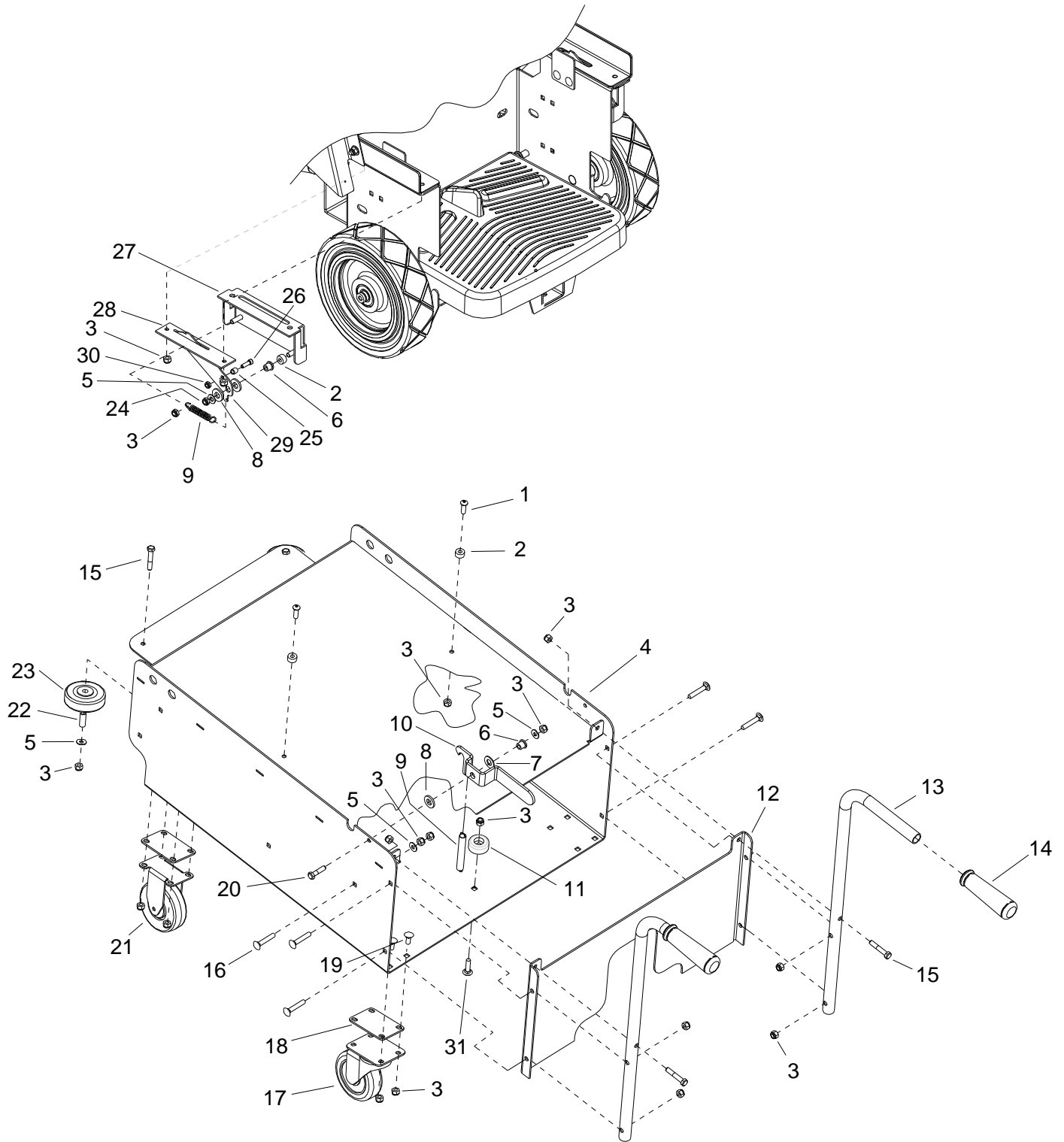

BATTERY CART - OPTION

REF	PART NO.	PRV NO.	QTY	DESCRIPTION	SERIAL NO. FROM	NOTES:
1	86006930	70514	2	SCR, 5/16-18 X 1.00 BSHCS SS		
2	86254290	730338	4	SPACER, 10D X .343ID, .5 LG		
3	86270830	57023	33	NUT, 5/16-18 HEX NYLOCK SS		
4	86077010	41517	1	HOUSING, BATTERY CART		
5	86010670	87029	7	WASHER, 5/16 FLAT SS		
6	86228840	09124	3	BEARING, FLANGED .314D X .502OD		
7	86259410	87206	1	WASHER, THRUST, .51 ID X 1 OD X .063		
8	86259400	730331	4	WASHER, THRUST .51 ID X 1 OD		
9	86254890	730018	3	SPRING, EXT, .50D X 4.0L		
10	86068490	140019	1	BRKT, TRAY CATCH		
11	86231090	80809	1	BUMPER, RUBBER 5/16" ID X 1.50		
12	86083120	66442	1	PLATE, BATTERY CART BACK		
13	86076600	38318	2	HANDLE, BATTERY CART		
14	86004070	36196	2	GRIP, POLISHER HANDLE		
15	86276790	70732	4	SCR, 5/16-18 X 1.75 HHCS SS		
16	86276690	70715	7	SCR, 5/16-18 X 1.75 CARR SS		
17	86199430	040-03	2	CASTER SWIVEL 4" 250# CPCTY		
18	86078890	620020	8	PLATE, CASTER SPACER		
19	86277130	70795	16	SCR, 5/16-18 X 1.00 CARRIAGE SS		
20	86007020	70673	1	SP SCR, 5/16-18 X 1.25 HHCS SS NP		
21	86232590	18032	2	CASTER, 4" HARD RUBBER RIGID		
22	86001350	140390	2	BUSHING, SPANNER .435 X 1.10		
23	86011020	89202	2	WHEEL, 3" DIA CUSHION RUBBER		
24	86271840	57285	2	NUT, 5/16-18 HEX NYLOCK THIN SS		
25	86008130	73958	2	SPACER, 3/8OD X .62W X .312L, AL		
26	86274730	70265	2	SCR, 1/4-20 X 3/4 SHCS PLTD		
27	86070790	140737	2	BRKT, BATTERY LOCK MOUNT		
28	86087340	730339	2	SPACER, LATCH GUIDE		
29	86070800	140738	2	BRKT, BATTERY TRAY LOCK		
30	86271870	57290	2	NUT, 1/4-20 HEX NYLOCK THIN SS		
31	86276070	70593	1	SCR, 5/16-18 X 3/4 CARRIAGE SS		

BATTERY CART - OPTION

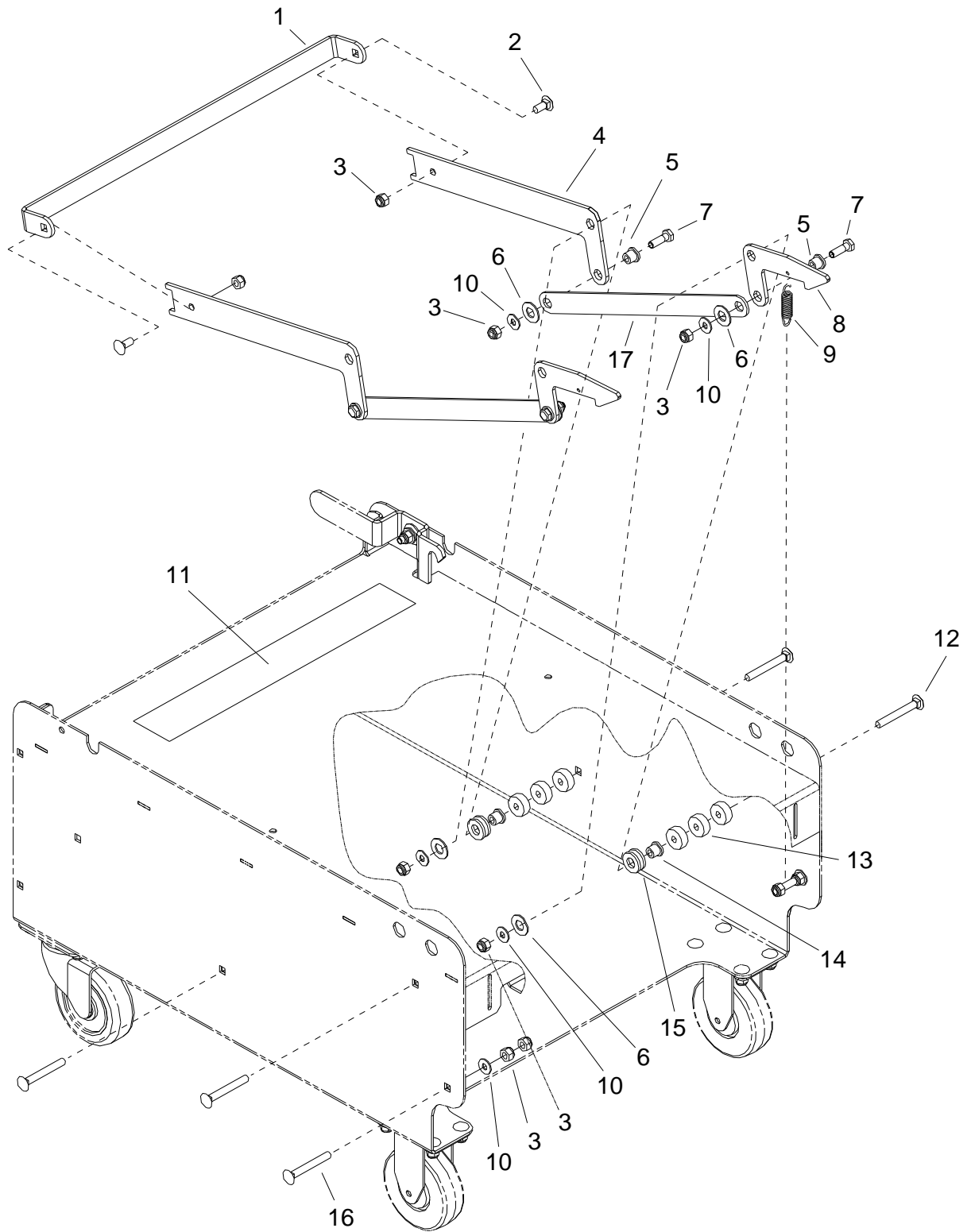

BATTERY CART - OPTION

REF	PART NO.	PRV NO.	QTY	DESCRIPTION	SERIAL NO. FROM	NOTES:
1	86078330	66478	1	PEDAL, BATTERY CART		
2	86276070	70593	2	SCR, 5/16-18 X 3/4 CARRIAGE SS		
3	86270830	57023	12	NUT, 5/16-18 HEX NYLOCK SS		
4	86087800	730307	2	STIFFENER, PEDAL, BATTERY CART		
5	86228840	09124	4	BEARING, FLANGED .314ID X .502OD		
6	86259410	87206	6	WASHER, THRUST .51 ID X 1 OD X .063		
7	86006560	70083	4	SCR, 5/16-18 X 1 HHCS SS NP		
8	86077140	51404	2	LATCH, BATTERY CART		
9	86226830	73268	2	SPRING, EXT .68D X 3.00L X .098W		
10	86010670	87029	10	WASHER, 5/16 FLAT SS		
11	86244280	500934	1	LABEL, BATTERY CAR OPERATION		
12	86276060	70590	4	SCR, 5/16-18 X 2.5 CARR GR5		
13	86254280	730331	12	SPACER, 1.00 ODX .32ID X .375		
14	86231150	09151	4	BUSHING FLANGE, .314 X .502 OD		
15	86259400	87205	8	WASHER, THRUST .51 ID X 1 OD BRO		
16	86276690	70715	16	SCR, 5/16-18 X 1.75 CARR SS		
17	86077530	51403	2	LINKAGE, LATCH, BATT CART		

SEAT - OPTION

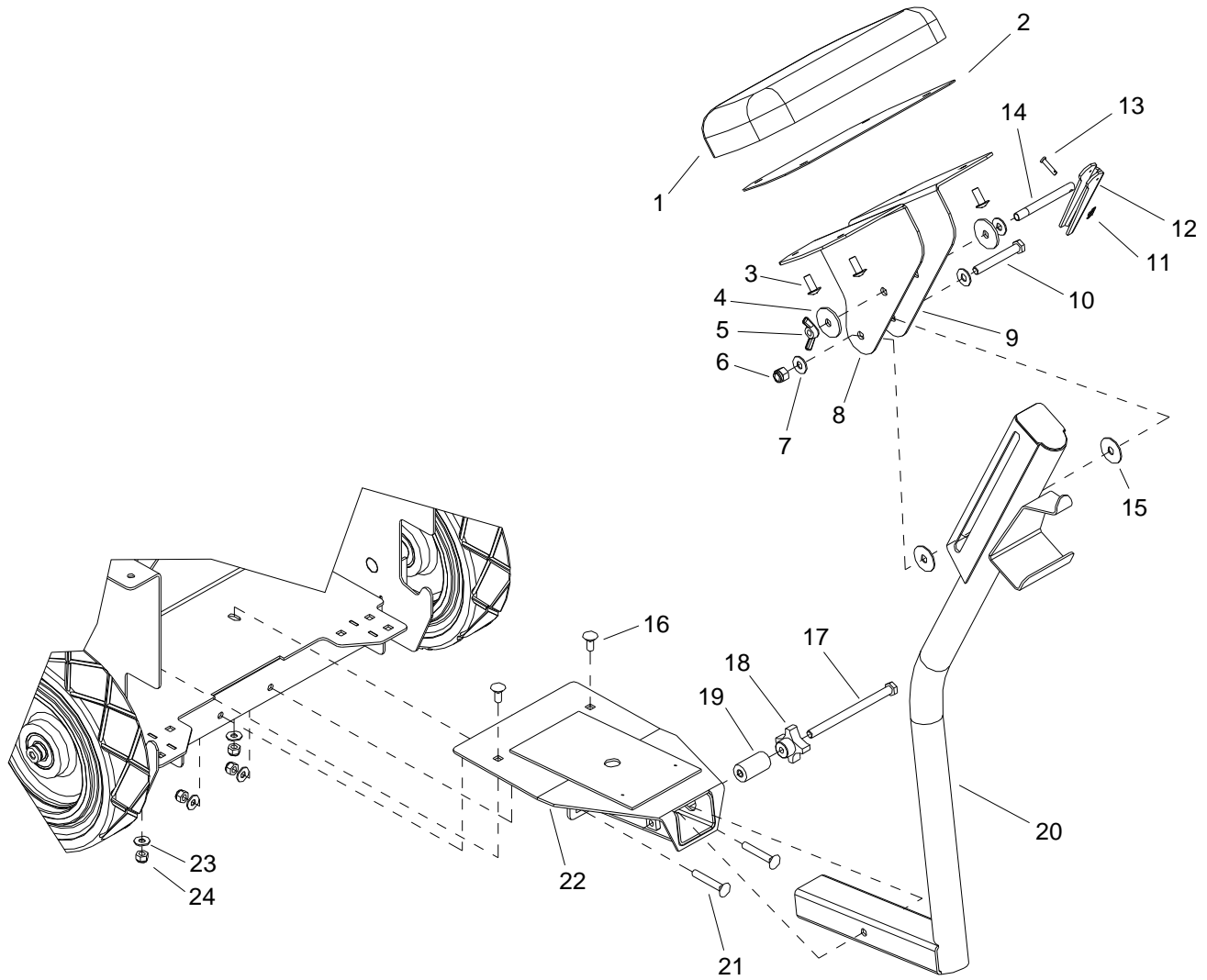

SEAT - OPTION

REF	PART NO.	PRV NO.	QTY	DESCRIPTION	SERIAL NO. FROM	NOTES:
1	86248390	730324	1	PAD, REAR REST		
2	86082640	629995	1	PLATE, SEAT COVER		
3	86276890	70752	4	SCR, 5/16-18 X 3/4 PTHMS SS		
4	86279460	87164	2	WASHER, 1/2 SPLIT LOCK PLTD		
5	86270710	01-000277	1	NUT, WING 3/8-16		
6	86271930	57297	1	NUT, 3/8-16 HEX NYLOCK SS		
7	86278910	87003	3	WASHER, 3/8 ID X 7/8 OD SS		
8	86070830	140742	1	BRKT, LEFT REAR SEAT		
9	86070840	140743	1	BRKT, RIGHT REAR SEAT		
10	86277710	730347	1	SCR, 3/8-16 X 2.75 HHCS SS		
11	86008650	80604	1	COTTER, 1/4" RING		
12	86246320	51142	1	LEVER, HANDLE LOCK		
13	86272300	66133	1	PIN, CLEVIS 3/16 X .88 PLTD		
14	86251860	66481	1	ROD, ARM HANDLE LOCK 4" LG		
15	86279620	87200	2	WASHER, .41D X 1.3OD NYLON		
16	86276070	70593	2	SCR, 5/16-18 X 3/4 CARRIAGE SS		
17	86277510	70857	1	SCR, 3/8-16 X 5.0 HHCS SS FT		
18	86009200	81535	1	KNOB, 3/8-16 4 PRONG ALUM		
19	86254300	730350	1	SPACER, SEAT LOCK		
20	86094000	05246	1	SEAT MOUNT POST		
21	86276710	70717	2	SCR, 5/16-18 X 2.0 CARRIAGE SS		
22	86093790	05247	1	RECEIVER ASSY, SEAT MOUNT		
23	86010670	87029	4	WASHER, 5/16 FLAT SS		
24	86270830	57023	4	NUT, 5/16-18 HEX NYLOCK SS		

WARNING LIGHTS - OPTION

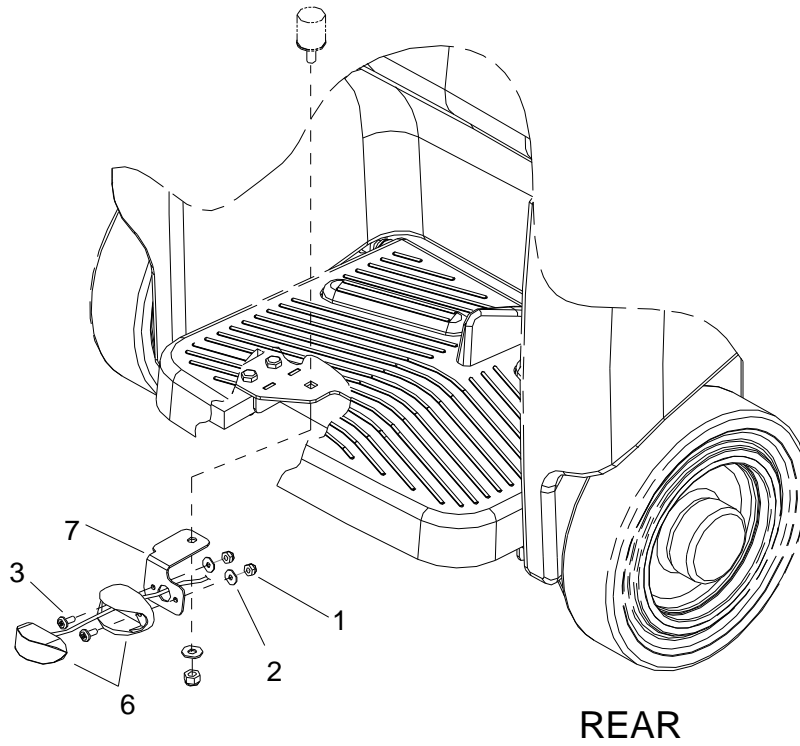
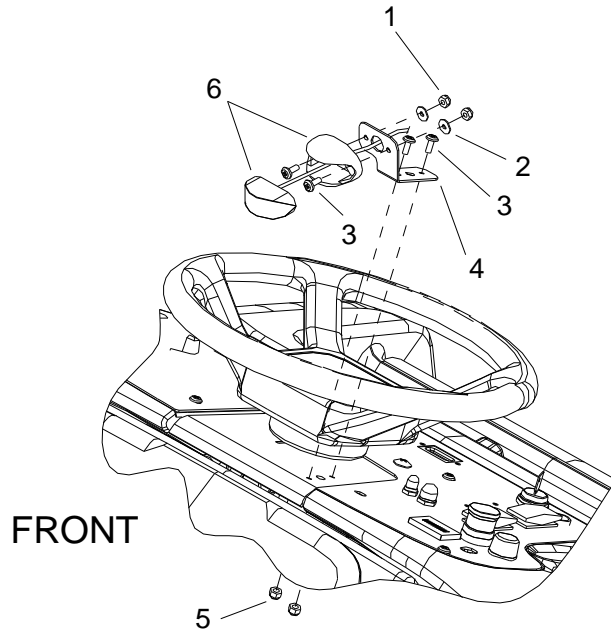

WARNING LIGHTS - OPTION

REF	PART NO.	PRV NO.	QTY	DESCRIPTION	SERIAL NO. FROM	NOTES:
1	86270990	57090	4	NUT, 10-32 HEX NYLOCK SS		
2	86010650	87018	4	WASHER, #10 X 9/16 OD		
3	86276820	70740	4	SCR, 10-32 X 1/2 PTHMS BLK NP		
4	86071490	140871	1	BRKT, UPPER WARNING LIGHT		
5	86270990	57090	2	NUT, 10-32 HEX NYLOCK SS		
6	86246200	51454	2	LED AMBER LIGHT, 12V		
7	86071500	140872	1	BRKT, LOWER WARNING LIGHT		

SERIAL NUMBERS

REF. NO.	MODEL: SERIAL #
1	CV28, CVE28, CVX28, CVXE28, CVXCD28: 1012521000022
2	CV28, CVE28, CVX28, CVXE28, CVXCD28: 1000160104
3	CV28, CVE28, CVX28, CVXE28, CVXCD28: 1000166771
4	CV28, CVE28, CVX28, CVXE28, CVXCD28: 1000168552
5	CV28, CVE28, CVX28, CVXE28, CVXCD28: 1000165165
6	CV28, CVE28, CVX28, CVXE28, CVXCD28: 1000157499
7	CV28, CVE28, CVX28, CVXE28, CVXCD28: 1000157501
8	CV28, CVE28, CVX28, CVXE28, CVXCD28: 1000160235
9	CV28, CVE28, CVX28, CVXE28, CVXCD28: 10060210000104
10	CV28, CVE28, CVX28, CVXE28, CVXCD28: 1000160355
11	CV28, CVE28, CVX28, CVXE28, CVXCD28: 1000158030
12	CV28: 102526000009, CVE28: 10125136000009, CVXE28: 1012518000015, CVX28: 1012519000329, CVX28X: 1012521000082, CV28X: 10125280000007, CVXCD28: 1012551000001
13	CV28: 1025260000051, CVE28: 101251600000010, CVXE28: 10125180000014, CVX28: 1012519000426, CVX28X: 1012521000095, CV28X: 10125280000010, CVXCD28: 1012551000003
14	CV28: 101252600000056, CVE28: 10125160000012, CVXE28: 10125180000004, CVX28: 10125190000449, CVXCD28: 10125510000004
15	CV28: 101252600000056, CVE28: 10125160000012, CVXE28: 10125180000004, CVX28: 1012519000470, CVX28X: 1012521000103, CV28X: 10125280000012, CVXCD28: 1012551000005, CVXCD28X: 1012556000005
16	CV28: 101252600000058, CVE28: 10125160000012, CVXE28: 10125180000012, CVX28: 10125190000491, CVXCD28: 10125510000005
16	CVXE28: 10125180000023, CVX28: 10125190000557, CVXCD28: 10125510000005
17	CV28: 10125260000061, CVE28: 10125160000012, CVXE28: 10125180000025, CVX28: 1012519000585, CVXCD28: 1012551000005
18	CV28: 10125260000061, CVE28: 10125160000012, CVXE28: 10125180000025, CVX28: 1012519000601, CVXCD28: 1012551000005