

SABER COMPACT™

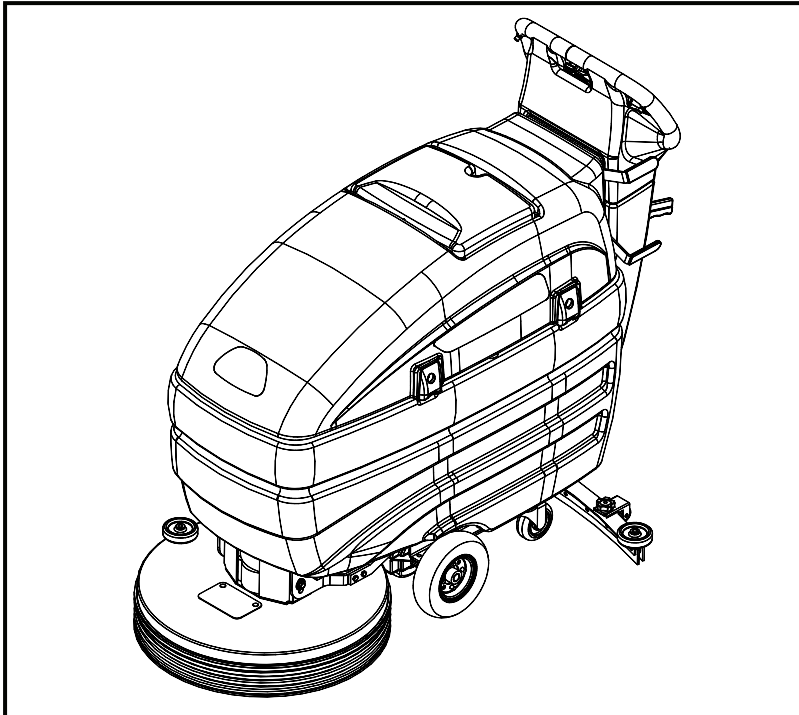

WALK BEHIND SCRUBBER



Operating Instructions
Bedienungsanleitung

MODELS:	<u>SC20</u> 10052190	<u>SCC20</u> 10052230
	<u>SC20T</u> 10052200	<u>SCC20T</u> 10052240
	<u>SCX20T</u> 10052370	<u>SCXC20T</u> 10052420

QUEST® ... for Continuous Improvement.
Windsor's Quality Management System is Certified ISO 9001.



*Read these instructions before using the machine
Bitte lesen Sie diese Anleitungen, bevor Sie die Maschine in Gebrauch nehmen*



86038350 04/26/12

PRV NO. 98712

MACHINE DATA LOG/OVERVIEW

MODEL	_____
DATE OF PURCHASE	_____
SERIAL NUMBER	_____
SALES REPRESENTATIVE #	_____
DEALER NAME	_____
OPERATIONS GUIDE NUMBER	_____
PUBLISHED	_____

YOUR DEALER

Name: _____

Address: _____

Phone Number: _____

OVERVIEW

The Saber Compact is a battery powered, hard floor scrubber intended for commercial use. The appliance applies a cleaning solution onto a hard floor, scrubs the floor with a brush or pad, and then vacuums the soiled water back into the recovery tank.

Warranty Registration

Thank you for purchasing a Windsor product. Warranty registration is quick and easy. Your registration will allow us to serve you better over the lifetime of the product.

To register your product go to:

www.windsorind.com/WarrantyRegistration.aspx

For customer assistance:

1-800-444-7654



TABLE OF CONTENTS

Machine Data Log/Overview.....	2
Table of Contents.....	3

HOW TO USE THIS MANUAL

How to use this Manual.....	1-1
-----------------------------	-----

SAFETY

Important Safety Instructions	2-1
Hazard Intensity Level.	2-2
Safety Label Location.	2-3

OPERATIONS

Technical Specifications.	3-1
How the Machine Works.....	3-3
Components.....	3-4
Controls.....	3-5
Machine Operation.....	3-10
Pre-Run Machine Inspection.....	3-10
Starting Machine.....	3-10
Emergency Stop Procedures	3-10
Filling the Solution Tank.....	3-10
Scrubbing.....	3-10
Emptying & Cleaning Tanks.....	3-12

MAINTENANCE

Batteries.....	4-1
Battery Maintenance.....	4-1
Checking Battery Specific Gravity.....	4-2
Charging the Batteries.	4-2
On-Board Charger Battery Selection	4-4
Changing Batteries.	4-5
Battery Connections.....	4-5
Scrub Brushes.	4-6
Types.....	4-6
Replacing or Installing Scrub Brushes	4-6
Squeegee Blades.....	4-7
Replace Squeegee Blade.	4-7
Remove Squeegee Assembly.....	4-7
Adjusting Deluxe Squeegee.....	4-7
Adjusting Squeegee Deflection.....	4-8
Replacing Squeegee Blades.....	4-8
Greasing Axles.....	4-8
Service Schedule.....	4-9
Machine Troubleshooting.....	4-10

GROUP PARTS LIST

Control Handle Group – Non-Traction.....	5-1
Control Tower Group - Traction.....	5-3
Decal Group.....	5-5
Electrical Panel Group – Non-Traction.	5-7
Electrical Panel Group – Traction.....	5-9
Hour Meter.....	5-11
Recovery Tank Group.....	5-13
Scrub Brush/Pad Driver Group	5-15
Scrub Head Group – Non-Traction.....	5-17
Scrub Head Group - Traction.....	5-19
Scrub Head Lift Group – Non-Traction.	5-21
Scrub Head Lift Group - Traction.....	5-23
Solution Tank Group – Non-Traction.	5-25
Solution Tank Group – Traction.....	5-27
Squeegee Group	5-29
Squeegee Lift Group.....	5-31
Deluxe Squeegee Group.	5-33
Deluxe Squeegee Lift Group.	5-37
Vacuum Group.....	5-39
Wheels and Frame Group – Non-Traction..	5-41
Wheels and Frame Group - Traction	5-43
Onboard Charger.....	5-45
Wiring Group – Battery Cables.....	5-47
Wiring Group–Control Panel-Non-Traction	5-49
Wiring Group-Control Panel-Non-Traction	
With Battery Charger	5-51
Wiring Group – Schematic – Non-Traction .	5-53
Wiring Group – Schematic – Non-Traction	
Onboard Charging	5-55
Wiring Group – Schematic - Traction.....	5-57
Wiring Group –Schematic – Traction and	
Onboard Charging	5-59
Wiring Group – Control Panel - Traction....	5-61
Wiring Group – Main Harness - Traction	5-63
Emergency Stop Option.....	5-65
Accessory Pump Option.	5-67
Suggested Spare Parts.....	5-69
EC Declaration of Conformity.	5-70
Serial Number.....	5-72
Warranty	

HOW TO USE THIS MANUAL

This manual contains the following sections:

- HOW TO USE THIS MANUAL
- SAFETY
- OPERATIONS
- MAINTENANCE
- PARTS LIST

The HOW TO USE THIS MANUAL section will tell you how to find important information for ordering correct repair parts.

Parts may be ordered from authorized Windsor dealers. When placing an order for parts, the machine model and machine serial number are important. Refer to the MACHINE DATA box which is filled out during the installation of your machine. The MACHINE DATA box is located on the inside of the front cover of this manual.

MODEL _____
DATE OF PURCHASE _____
SERIAL NUMBER _____
SALES REPRESENTATIVE # _____
DEALER NAME _____
OPERATIONS GUIDE NUMBER _____
PUBLISHED _____

Copyright 1995 Windsor Industries, Printed in USA

The model and serial number of your machine is on the front of the control tower.

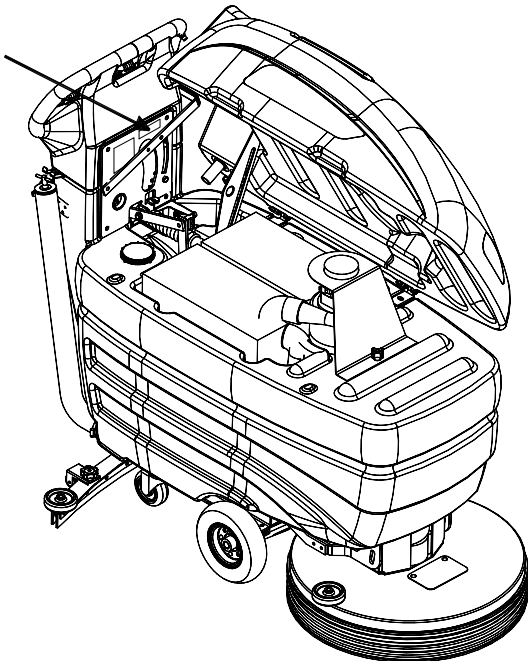

The SAFETY section contains important information regarding hazard or unsafe practices of the machine. Levels of hazards are identified that could result in product or personal injury, or severe injury resulting in death.

The OPERATIONS section is to familiarize the operator with the operation and function of the machine.

The MAINTENANCE section contains preventive maintenance to keep the machine and its components in good working condition. They are listed in this general order:

- Batteries
- Scrub Brushes
- Squeegee
- Service Schedule
- Machine Troubleshooting

The PARTS LIST section contains assembled parts illustrations and corresponding parts list. The parts lists include a number of columns of information:

- **REF** – column refers to the reference number on the parts illustration.
- **PART NO.** – column lists the part number for the part.
- **PRV NO.** – reference number
- **QTY** – column lists the quantity of the part used in that area of the machine.
- **DESCRIPTION** – column is a brief description of the part.
- **SERIAL NO. FROM** – If this column has an (*) and a Reference number, see the SERIAL NUMBERS page in the back of your manual. If column has two asterisk (**), call manufacturer for serial number. The serial number indicates the first machine the part number is applicable to. The main illustration shows the most current design of the machine. When a boxed illustration is shown, it displays the older design..
- **NOTES** – column for information not noted by the other columns.

NOTE: If a service or option kit is installed on your machine, be sure to keep the KIT INSTRUCTIONS which came with the kit. It contains replacement parts numbers needed for ordering future parts.

IMPORTANT SAFETY INSTRUCTIONS

When using an battery powered appliance, basic precaution must always be followed, including the following:

READ ALL INSTRUCTIONS BEFORE USING THIS MACHINE.



WARNING:

To reduce the risk of fire, electric shock, or injury:

Use only indoors. Do not use outdoors or expose to rain.

Use only as described in this manual. Use only manufacturer's recommended components and attachments.

If the machine is **not working properly**, has been dropped, damaged, left outdoors, or dropped into water, return it to an authorized service center.

Do not operate the machine with any openings blocked. Keep openings free of debris that may reduce airflow.

This machine **is not** suitable for picking up hazardous dust.

Machine can cause a fire when operating near flammable vapors or materials. Do not operate this machine near flammable fluids, dust or vapors.

This machine is suitable for commercial use, for example in hotels, schools, hospitals, factories, shops and offices for more than normal housekeeping purposes.

Maintenance and repairs **must be done** by qualified personnel.

If foam or liquid comes out of machine, **switch off immediately**.

Disconnect battery before cleaning or servicing.

Before the machine is discarded, the batteries **must be removed** and properly disposed of.

Make sure all warning and caution labels **are legible and properly attached** to the machine.

During operation, attention shall be paid to other persons, especially children.

Before use all covers and doors shall be put in the positions specified in the instructions.

When leaving unattended, secure against unintentional movement.

The machine shall only be operated by instructed and authorized persons.

When leaving unattended, switch off or lock the main power switch to prevent unauthorized use.

Only chemicals recommended by the manufacturer shall be used.

This appliance has been designed for use with the brushes specified by the manufacturer. The fitting of other brushes may affect its safety.

Do not use on surfaces having a gradient exceeding 2%.

SAVE THESE INSTRUCTIONS

HAZARD INTENSITY LEVEL

The following symbols are used throughout this guide as indicated in their descriptions:

HAZARD INTENSITY LEVEL

There are three levels of hazard intensity identified by signal words -**WARNING** and **CAUTION** and **FOR SAFETY**. The level of hazard intensity is determined by the following definitions:

⚠ WARNING

WARNING - Hazards or unsafe practices which COULD result in severe personal injury or death.

⚠ CAUTION

CAUTION - Hazards or unsafe practices which could result in minor personal injury or product or property damage.

FOR SAFETY: To identify actions which must be followed for safe operation or equipment.

Report machine damage or faulty operation immediately. Do not use the machine if it is not in proper operating condition. Following is information that signals some potentially dangerous conditions to the operator or the equipment. Read this information carefully. Know when these conditions can exist. Locate all safety devices on the machine. Please take the necessary steps to train the machine operating personnel.

FOR SAFETY

DO NOT OPERATE MACHINE:

Unless Trained and Authorized.

Unless Operation Guide is Read and understood.

In Flammable or Explosive areas.

In areas with possible falling objects.

WHEN SERVICING MACHINE:

Avoid moving parts. Do not wear loose clothing; jackets, shirts, or sleeves when working on the machine. Use Windsor approved replacement parts.

⚠ WARNING

Batteries emit hydrogen gas. Explosion or fire can result. Keep sparks and open flame away. Keep solution tank in raised position when charging. Keep sparks and flames away from the batteries. Do not smoke around batteries.

⚠ WARNING

Disconnect batteries before working on machine. Only qualified personnel should work inside machine. Always wear eye protection and protective clothing when working on or near batteries. Avoid skin contact with the acid contained in the batteries.

⚠ WARNING

Never allow metal to lie across battery tops.

SAFETY LABEL LOCATION

NOTE: These drawings indicate the location of safety labels on the machine. If at any time the labels become illegible, promptly replace them.



SAFETY DECAL
86252530
PRV NO. 81494

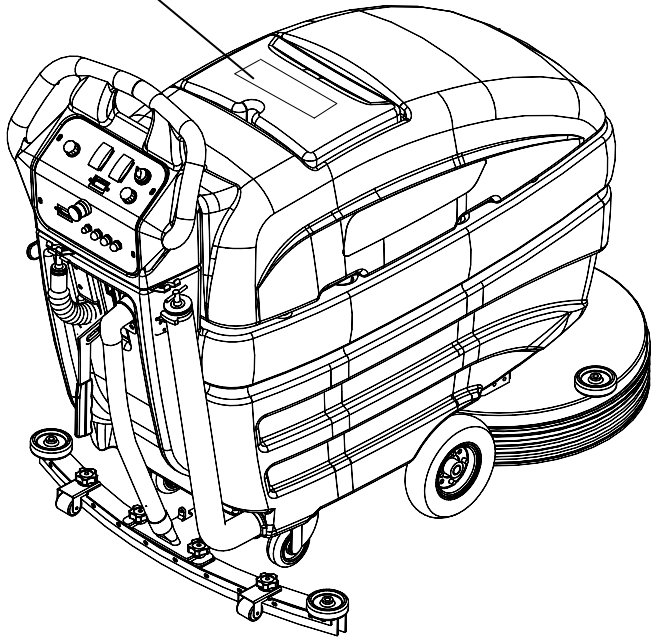

BATTERY CAUTION
86252520
PRV NO. 80885

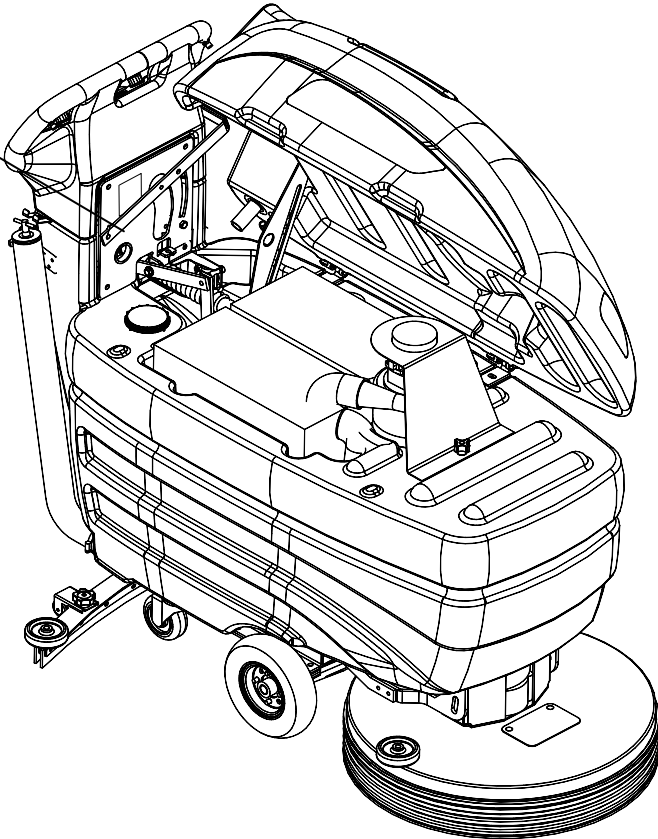

TECHNICAL SPECIFICATIONS

ITEM	DIMENSION/CAPACITY
Nominal power – non-traction model	1100 W
Nominal power – traction model	1200 W
Rated Voltage	24VDC
Rated Amperage – non-traction model	45 Amps
Rated Amperage – traction model	50 Amps
Batteries	2 x 12 Volt 105-130-195 AH @ 20hr rate
Scrub Brush Motor	.75 hp (0.56 kW)
Vacuum Motor	.75 hp (0.56 Kw)
Propelling Motor – traction model	.38 hp (0.28 Kw)
Mass (GVW) – non-traction model	543 lbs. (246.5 kg)
Mass (GVW) – traction model	556 lbs. (252.4 kg)
Weight empty without batteries – non-traction model	213 lbs. (96.1 kg)
Weight empty without batteries – traction model	232 lbs. (105.3 kg)
Solution Control – non-traction model	Gravity feed, fully variable
Solution Control – traction model	Gravity feed, fully variable with automatic shut-off in neutral
Solution tank capacity	13 gal. (50 l)
Recovery tank capacity	16 gal. (60 l)
Scrub brush diameter	20 in (51 cm)
Scrub brush pressure – non-traction model	50 lbs. (23 kg)
Scrub brush pressure – traction model	100 lbs. (45 kg)
Scrub brush speed	200 rpm
Tires – non-traction model	2 x 8 in (20 cm) thermoplastic elastomer non-marking
Tires – traction model	2 x 8 in (20 cm) foam filled non-marking
Casters	3.5 x 1.25 in (9 cm) polyurethane solid non-marking
Foundation Pressure – non-traction model	105 lbs./in ² (725 kPa)
Foundation Pressure – traction model	46 lbs./in ² (315 kPa)
Maximum Speed – traction model	2.75 miles/hour (4.5 km/hour)
Frame Construction	Steel with epoxy powdercoat finish.
Minimum aisle u-turn width	45 in. (114.3 cm)
Maximum rated climb and descent angle with empty tanks	2%
Maximum rated climb and descent angle with full tanks	2%

TECHNICAL SPECIFICATIONS

ITEM	MEASURE
Height	43 in. (109.2 cm)
Length	54 in. (137.1 cm)
Width without squeegee	22 in. (55.9 cm)
Width of squeegee	31 in. (78.7 cm)
Width of scrub path	20 in. (51 cm)

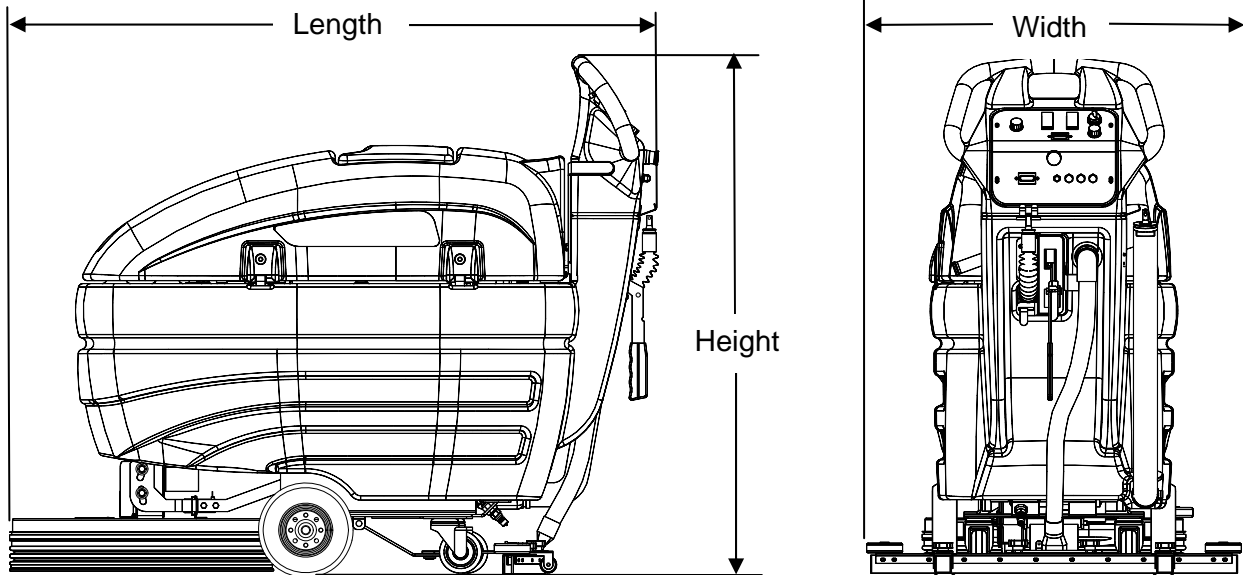

SPECIAL NOTES:

The A-weighted sound pressure level emitted by the appliance was measured to be 72.5 dBA. This is a space-averaged, broad-band measurement determined according to IEC 704-I. This appliance contains no possible source of impact noise.

The overall root-mean-square acceleration at the operator's arms was measured to be less than 1.0m/s^2 . This is a tri-axial, broad-band measurement made during normal operation on a composite tile floor.

HOW THE MACHINE WORKS

The Saber Compact is a battery powered, hard floor scrubber intended for commercial use. The appliance applies a cleaning solution onto a hard floor, scrubs the floor with a brush, and then vacuums the soiled water back into the recovery tank.

The machine's primary systems are the solution system, scrub system, recovery system. The traction model has a directional control system as well.

The function of the solution system is to store cleaning solution and deliver it to the scrub system. The solution system consists of the solution tank, strainer, valve and controls. The solution tank stores cleaning solution (water and detergent) until it is delivered to the scrub system. The strainer protects the valve from debris. The non-traction model has a ball-type valve which controls the delivery of cleaning solution to the scrub system. The traction model has a solenoid type valve, which controls the delivery of cleaning solution to the scrub system. The valve automatically prevents solution flow unless the scrub brushes are turned on and the machine is being propelled. The solution control knob controls the amount of cleaning solution delivered to the scrub system.

The function of the scrub system is to scrub the floor. The scrub system consists of a rotary type disk scrub brush, motor, self-adjusting scrub deck skirt, lift linkage and controls. The brush scrubs the floor and the motor drives the brush. The brush drive hub allows the scrub brush to follow irregularities and changes in the floor without losing contact with floor. The self-adjusting scrub deck skirt controls the cleaning solution on the floor so that the squeegee can pick it up. The brush lift lever raises and lowers the scrub deck. On the traction model the brush lift lever can be locked into an increased brush pressured position.

The function of the recovery system is to vacuum the soiled water back into the recovery tank. The recovery system consists of the squeegee, vacuum motor, screen, recovery tank and controls. The squeegee wipes the dirty solution off the floor as the machine moves forward. The vacuum motor provides suction to draw the dirty solution off the floor and into the recovery tank. The screen protects the vacuum fan from debris. The recovery tank stores the dirty solution. The float ball in the tank activates when the recovery tank is full.

On the traction model, the function of the directional control system is to control the direction and speed of the machine. The directional control system consists of buttons, speed control knob/potentiometer, controller and transaxle. The speed control knob actuates a potentiometer, which signals speed. The controller interprets the forward/reverse signals from the buttons and the speed signal from the potentiometer to command the transaxle to propel the machine in the direction, and at the speed, desired.

The buttons on the control handles signal forward. When the reverse button on the control panel is pushed, in addition to either button on the control handles, reverse is signaled.

COMPONENTS

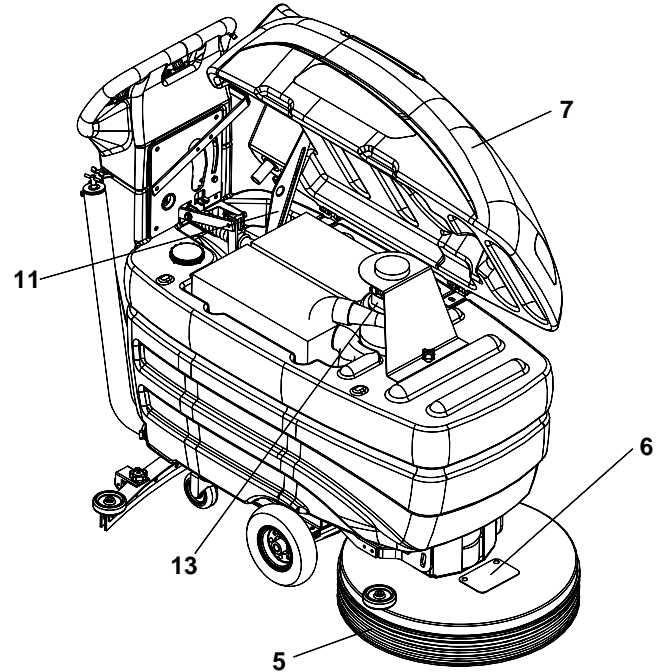
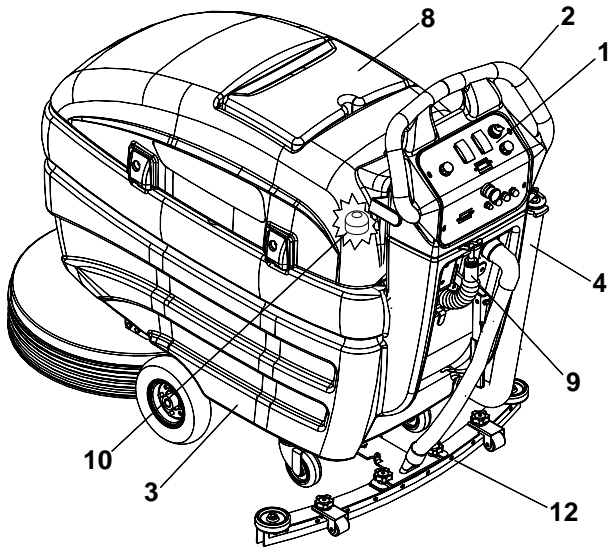

1. **Control Panel**
2. **Control Handle**
3. **Recovery Tank**
4. **Recovery Tank Drain Hose**
5. **Scrub Head**
6. **Scrub Brush Access Cover**
7. **Solution Tank**
8. **Solution Tank Cover**
9. **Solution Tank Drain Hose**
10. **Solution Strainer**
11. **Solution Tank Support Arm**
12. **Squeegee**
13. **Vacuum Motor**

CONTROLS – NON-TRACTION

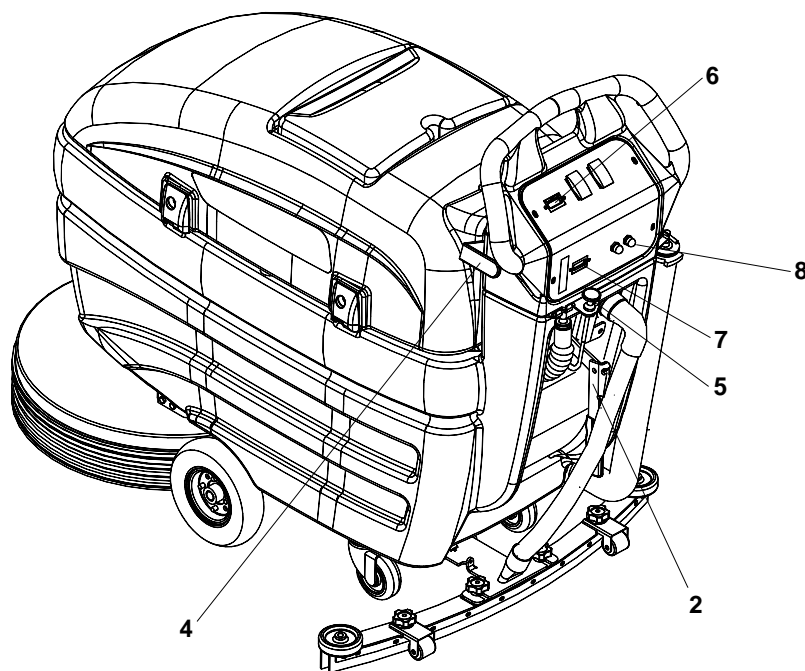
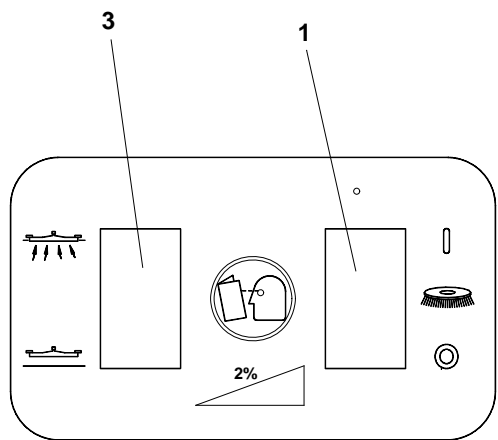

1. **Brush Switch**
2. **Brush Lift Lever**
3. **Vacuum Switch**
4. **Squeegee Lift Lever**
5. **Solution Control Lever**
6. **Battery Charge Level Indicator**
7. **Hour Meter (Optional)**
8. **Circuit Breakers**

CONTROLS – NON TRACTION

1. BRUSH SWITCH

Controls the scrub brush motor.

To turn scrub brush on, press the top of the switch.

To turn scrub brush off, press the bottom of the switch.

2. BRUSH LIFT LEVER

Raises and lowers the brush.

To lower the brush, lift the lever from the notch, move to the left, then lower.

To raise the brush, lift the lever from its lowered position.

3. VACUUM SWITCH

Controls the vacuum motor.

To start vacuum motor, press the top of the switch.

To stop vacuum motor, press the bottom of the switch.

4. SQUEEGEE LIFT LEVER

Raises and lowers the squeegee.

To lower the squeegee, lift and pull the lever to the left and then lower.

To raise the squeegee, lift the lever and push it to the right.

5. SOLUTION CONTROL LEVER

Controls solution flow to scrub deck.

To increase flow pull and raise the knob to the desired flow.

To decrease flow push the knob down.

6. BATTERY CHARGE LEVEL INDICATOR

Indicates the charge level of the batteries.

The meter display is divided into 10 vertical bars. Bars illuminated on the far right indicate full charge. Bars flashing near the left side indicate the batteries should be recharged. Further operation of the machine could damage the machine or the batteries.

When the machine is left overnight with less than a full charge, the display may initially indicate a full charge. It will also indicate a full charge if the batteries are disconnected, then reconnected. After a few minutes of operation the meter will give the correct charge level.

7. HOUR METER (OPTIONAL)

Records the number of hours the machine's brush has been in operation. This information is useful in determining when to service the machine.

8. CIRCUIT BREAKERS

Circuit breakers interrupt the flow of power in the event of an electrical overload. When a circuit breaker is tripped, reset it by pressing the exposed button. If a circuit breaker continues to trip, the cause of the electrical overload should be found and corrected.

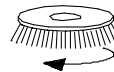

30 Amp. Protects the scrub brush motor.



30 Amp. Protects the vacuum motor.

CONTROLS - TRACTION

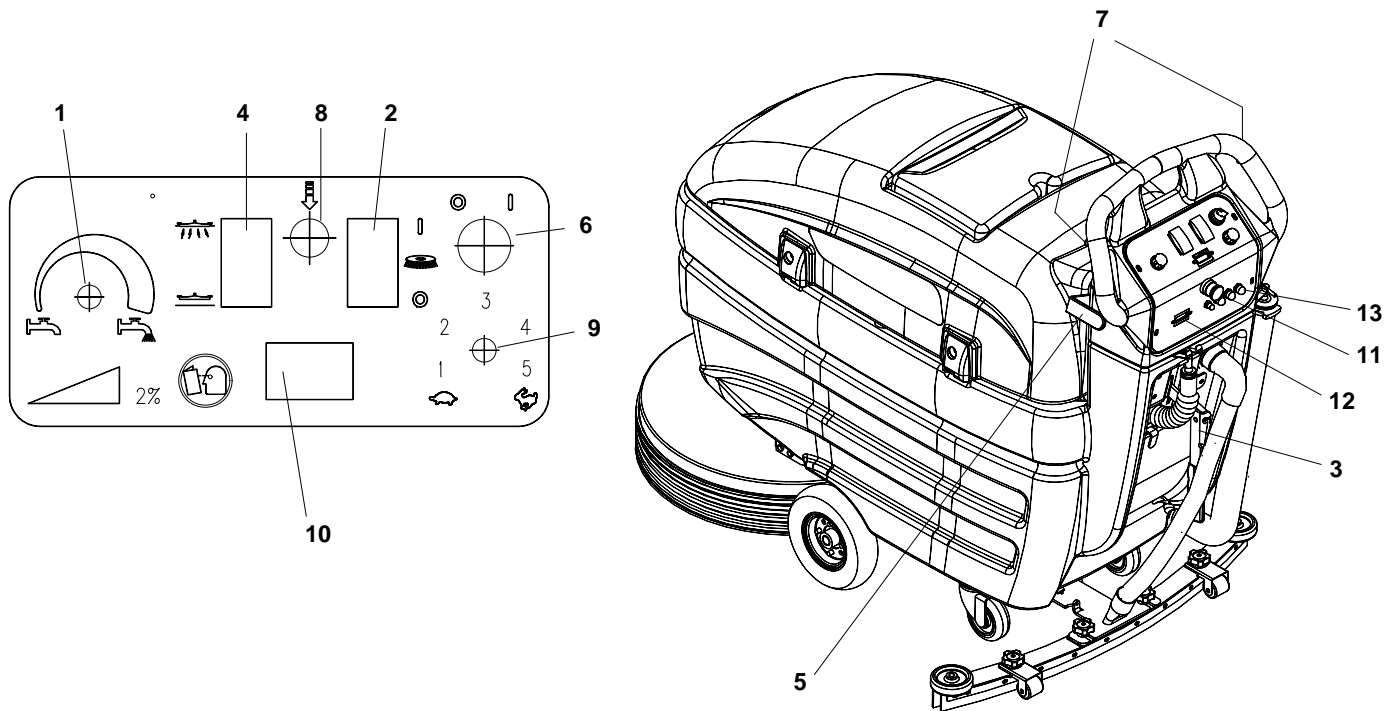

1. **Solution Control Knob**
2. **Brush Switch**
3. **Brush Lift Lever**
4. **Vacuum Switch**
5. **Squeegee Lift Lever**
6. **Key Switch**
7. **Propel Buttons (Normally Forward)**
8. **Reverse Propel Button**
9. **Speed Control Knob**
10. **Battery Charge Level Indicator**
11. **Emergency Shut Off Switch (Optional)**
12. **Hour Meter (Optional)**
13. **Circuit Breakers**

CONTROLS - TRACTION

1. SOLUTION CONTROL KNOB

Controls solution flow to scrub deck.

To increase flow, rotate knob clockwise.

To decrease flow, rotate knob counterclockwise.

If the brush motor is turned off or the direction control lever is in neutral, the flow is automatically interrupted until the motor is turned on again. This feature prevents unintentional draining of the solution tank and allows the operator to adjust the solution flow to the scrub deck without resetting each time the scrubbing operation is interrupted.

2. BRUSH SWITCH

Controls the scrub brush motor.

To turn scrub brush on, press the top of the switch. The brush will not rotate with the direction control lever in neutral.

To turn the scrub brush off, press the bottom of the switch.

3. BRUSH LIFT LEVER

Raises and lowers the brush.

To lower the brush, lift the lever from the notch, move to the left, then lower.

To increase brush pressure, lock the lever into the lowered position.

To raise the brush, lift the lever from its lowered position and lock into highest notch.

4. VACUUM SWITCH

Controls the vacuum motor.

To start vacuum motor, press the top of the switch.

To stop vacuum motor, press the bottom of the switch.

5. SQUEEGEE LIFT LEVER

Raises and lowers the squeegee.

To lower the squeegee, lift and pull the lever to the left and then lower.

To raise the squeegee, lift the lever and push it to the right.

6. KEY SWITCH

Controls the power for machine functions.

To turn machine on, rotate key clockwise.

To turn machine off, rotate key counterclockwise.

FOR SAFETY: Always remove the key when machine is unattended or during service to prevent unauthorized movement.

7. PROPEL BUTTONS (NORMALLY FORWARD)

Controls the machine direction, scrub brush and solution flow.

To propel machine forward, push the button on either of the control handles.

The scrub brush will not rotate and the solution will not flow to the scrub deck unless a propel button is pushed.

8. REVERSE PROPEL BUTTON

Controls the machine direction in reverse.

To propel machine backward, push the button on the control panel and one of the buttons on either of the control handles.

CONTROLS - TRACTION

9. SPEED CONTROL KNOB

Controls the speed of the machine.

To increase speed, rotate knob clockwise.

To decrease speed, rotate knob counterclockwise.

10. BATTERY CHARGE LEVEL INDICATOR

Indicates the charge level of the batteries.

The meter display is divided into 10 vertical bars. Bars illuminated on the far right indicate full charge. Bars flashing near the left side indicate the batteries should be recharged. Further operation of the machine could damage the machine or the batteries.

When the machine is left overnight with less than a full charge, the display may initially indicate a full charge. It will also indicate a full charge if the batteries are disconnected, then reconnected. After a few minutes of operation the meter will give the correct charge level.

11. EMERGENCY SHUT-OFF SWITCH (OPTIONAL)

Shuts off machine.

To shut off machine, push the switch.

To restart machine, rotate the switch clockwise.

12. HOUR METER (OPTIONAL)

Records the number of hours the machine's brush has been in operation. This information is useful in determining when to service the machine.

13. CIRCUIT BREAKERS

Circuit breakers interrupt the flow of power in the event of an electrical overload. When a circuit breaker is tripped, reset it by pressing the exposed button. If a circuit breaker continues to trip, the cause of the electrical overload should be found and corrected.



3 Amp. Protects the machine controls.

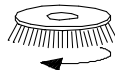

30 Amp. Protects the scrub brush motor.



30 Amp. Protects the vacuum motor.



25 Amp. Protects the propel motor.

MACHINE OPERATION

PRE-RUN MACHINE INSPECTION

Do a pre-run inspection to find possible problems that could cause poor performance or lost time from breakdown. Follow the same procedure each time to avoid missing steps.

NOTE: See maintenance section for pre-run machine inspection checklist items.

STARTING MACHINE

NOTE: Perform pre-run machine check before operating machine.

FOR SAFETY: Before starting machine, make sure that all safety devices are in place and operating properly.

1. Turn the machine power on.
2. Press the directional control button(s) to move in the desired direction, if your machine is traction model.

EMERGENCY STOP PROCEDURES

1. Release the directional control button(s), if your machine is traction model.
2. Turn machine power off.
3. If an electrical problem is suspected push in emergency stop button, if machine is equipped with this option.

FILLING SOLUTION TANK

FOR SAFETY: Before leaving or servicing machine; stop on level surface, turn off machine and remove key.

1. Turn the machine power off.
2. Remove solution tank cover.
3. Fill the solution tank with clean water, leaving enough room for the required amount of cleaning solution. The solution tank capacity is 13 gallons (50 liters). The water must not be hotter than 140° F (60°C) to prevent damage to the tank.

4. **Measure** the chemical into the solution tank. Liquid chemicals should be added to the solution tank after filling with water. Dry chemicals should be thoroughly mixed before being added into the solution tank. Commercially available, high alkaline floor cleaners, are suitable for use in the solution system.

NOTE: Read the chemical manufacturers recommended proportion instructions.

5. Replace solution tank cover.

WARNING

Flammable materials can cause an explosion or fire. Do not use flammable materials in the tanks.

NORMAL SCRUBBING

Plan the scrubbing pattern in advance. The longest track is around the perimeter of the area to be cleaned. For efficient operation, the runs should be the longest possible without turning, stopping, or raising and lowering scrub deck/squeegee.

NOTE: In order to achieve the best possible results, the area which is to be cleaned should be swept before scrubbing. Large debris, strings & wire must be removed to prevent being caught in the brush or squeegee.

INEFFICIENT SCRUBBING PATH

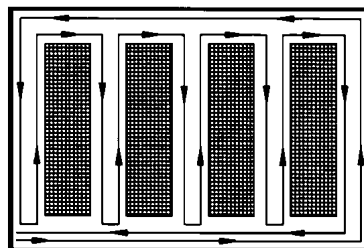

RECOMMENDED SCRUBBING PATH

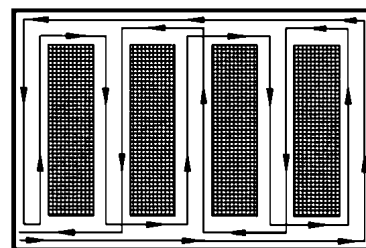

MACHINE OPERATION

TO BEGIN SCRUBBING

CAUTION

When operating the machine around people, pay close attention for unexpected movement. Use extra caution around children.

WARNING

Flammable liquids and/or reactive metals can cause explosions or fire! Do not pick up.

1. Turn the machine power on.
2. Lower the squeegee.
3. Turn the vacuum on.
4. Lower the scrub brush to the floor.
5. Turn the scrub brush on (for traction model, brush will start when machine is propelled).
6. Drive machine forward to begin scrubbing.
NOTE: Shut machine off immediately if water or foam is expelled from the machine.
7. Adjust the speed of the machine, solution flow and scrub brush pressure as necessary.
NOTE: For non-traction model, the solution flow must be shut off to prevent unintentional draining of solution tank. For traction model, once solution flow rate is set it is not necessary to shut off solution when stopping scrubbing. Solution flow is automatically shut off when the brush motor stops. When the brush motor is activated, flow will automatically resume.

TO STOP SCRUBBING

1. Release the directional control button(s), if your machine is traction model.
2. Turn the scrub brush off.
3. Raise the scrub brush.
4. Raise the squeegee.
5. Turn the vacuum off.
6. Turn the machine power off.

DOUBLE SCRUB

For floors which are heavily soiled or have thick accumulations of floor finish the machine may not clean sufficiently with one pass. In these cases it will be necessary to double scrub.

To double scrub, make the first pass over the surface being cleaned with the squeegee up, vacuum off, the solution on, and brush down and on. This allows the solution to stay in contact with the soil while loosening the surface accumulation with the brush. Allow time for the first application to stay in contact with the floor. The length of time between the first and second pass depends on the amount of accumulation and the type of chemical being used. A second scrubbing with the squeegee down, vacuum on and again with solution and brush on will further loosen the soil. The additional application of solution will further assist the difficult cleaning job.

FOR SAFETY: When using machine, go slow on inclines and slippery services.

EMPTYING AND CLEANING TANKS

1. Park the machine next to a floor drain. Drain hoses are on the rear of the machine.
2. Turn the machine power off.

SOLUTION TANK

1. Unhook the small drain hose from the retainer. Unscrew the T-handle plug enough to loosen it, then lower the hose in the direction of the drain. Slowly remove the plug from drain hose.
2. Remove the solution tank cover.
3. Flush the solution tank out with clean water and run several gallons of clean water through systems. Do not use water hotter than 140°F (60°C) to clean the tank, damage may occur.
NOTE: Never allow solution to remain in tank. Damage to tank, seals and valves could occur.
4. Replace the drain plug and secure the drain hose in the bracket.

RECOVERY TANK

1. Unhook the large drain hose from the retainer. Unscrew the T-handle on the plug enough to loosen it, then lower the hose in the direction of the drain. Do not stand in front of the end of the hose. Recovered solution will come out with force. Slowly remove the plug from the drain hose.
2. Raise the solution tank to access the recovery tank. Make sure the support arm is fully engaged. Remove the vacuum motor and rear access cover. Flush the recovery tank out with clean water. Do not use water hotter than 140°F (60°C) to clean the tank, damage may occur.
3. Clean off the float and check for free movement of the float ball. The float is attached to the bottom of the vacuum motor.
4. Replace the drain plug and secure the drain hose in the bracket.
5. If the machine is to be stored, leave solution tank in the raised position.

MAINTENANCE

BATTERIES

The batteries provide the power to operate the machine. The batteries require regular maintenance to keep them operating at peak efficiency.

The machine batteries will hold their charge for long periods of time, but they can only be charged a certain number of times. To get the greatest life from the batteries, charge them when their charge level reaches 25% of a full charge. Use a hydrometer to check the charge level.

Do not allow the batteries to remain in a discharged condition for any length of time. Never expose a discharged battery to temperatures below freezing. Discharged batteries will freeze causing cracked cases. Do not operate the machine if the batteries are in poor condition or if they have a charge level below 25% (specific gravity below 1.155).

Keep all metallic objects off the top of the batteries, as they may cause a short circuit. Replace worn or damaged cables and terminals.

Check the electrolyte level in each battery cell before and after charging the batteries. Never add acid to the batteries, use distilled water. Do not allow water level to fall below the battery plates. Portions of plates exposed to air will be destroyed. Do not overfill. Keep plugs firmly in place at all times.

⚠ CAUTION

When servicing machine, avoid contact with battery acid.

⚠ WARNING

Batteries emit hydrogen gas. Explosion or fire can result. Keep sparks and open flame away. Keep covers open when charging.

⚠ WARNING

Wear eye protection and protective clothing when working with batteries.

⚠ WARNING

Charge batteries in a well ventilated area.

BATTERY MAINTENANCE

1. When cleaning the batteries, use a solution of baking soda and water. Do not allow the cleaning fluid to enter the battery cells, electrolyte will be neutralized.
2. Maintain the proper electrolyte level in each battery cell. If a cell should accidentally overflow, clean immediately.
3. Wipe off the top of the batteries at least once a week.
4. Test battery condition with a hydrometer at least once a week.
5. Ensure that all connections are tight and all corrosion removed.
6. Every 4 to 6 months, remove that batteries from the machine and clean the battery cases and battery compartment.

CHECKING BATTERY SPECIFIC GRAVITY

Use a hydrometer to check the battery specific gravity.

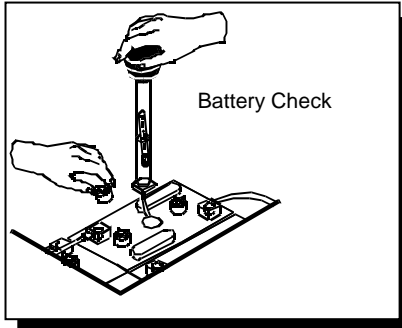

CHECKING GRAVITY

- A. Hydrometer
- B. Battery

NOTE: Do not take readings immediately after adding distilled water, if the water and acid are not thoroughly mixed, the reading may not be accurate.

Check the hydrometer readings against this chart.

SPECIFIC GRAVITY @ 80° F (27°C)	BATTERY CONDITION
1.265	100% CHARGED
1.225	75% CHARGED
1.190	50% CHARGED
1.155	25% CHARGED
1.120	DISCHARGED

NOTE: If the readings are taken when the battery electrolyte is any temperature other than 80° F (27°C), the reading must be temperature corrected.

To find the corrected specific gravity reading when the temperature of the battery electrolyte is other than 80°F (27°): Add (+) to the specific gravity reading 0.004 (4 points), for each 10°F (6°C) above 80° (27°C).

Subtract (-) from the specific reading 0.004 (4 points), for each 10°F (6°C) below 80°F (27°C).

TO CHARGE THE BATTERIES

⚠ CAUTION

When servicing machine, avoid contact with battery acid.

⚠ WARNING

Batteries emit hydrogen gas. Explosion or fire can result. Keep sparks and open flame away. Keep covers open when charging.

⚠ WARNING

Wear eye protection and protective clothing when working with batteries.

⚠ WARNING

Charge batteries in a well ventilated area. Leave the solution tank open.

Use a 24 volt, 20 amp maximum output, DC charger which will automatically shut off when the batteries are fully charged to charge the two battery pack.

1. Stop the machine in a clean, well ventilated area next to the charger.
2. Turn the machine power off.

FOR SAFETY: Before leaving or servicing machine; stop on level surface, turn off machine and remove key.

3. Drain solution tank and raise the solution tank and lock the support arm. Make sure the support arm is fully engaged.

⚠ WARNING

Batteries emit hydrogen gas. Explosion or fire can result. Keep sparks and open flame away. Keep covers open when charging.

MAINTENANCE

4. Check the electrolyte level in each battery cell. Before charging, add just enough distilled water to cover the plates. After charging is complete, add just enough distilled water to bring up the level to the indicator ring. If the water level is too high before charging, normal expansion rate of the electrolyte may cause an overflow. Resulting in a loss of battery acid balance and damage the machine.
5. Replace the battery caps, and leave them in place while charging.
6. Unplug the battery connector from the machine.

FOR SAFETY: When charging, connect the charger to the batteries before connecting the charger to the AC wall outlet. Never connect the charger to the AC wall outlet first. Hazardous sparks may result.

7. Plug the charger connector into the battery connector. Connect the charger AC plug to a wall outlet. The charger gauge should indicate that the batteries are charging.
8. When the batteries are fully charged, disconnect the charger from the AC wall outlet, then disconnect the charger from the batteries.
9. Connect the batteries to the machine connector.
10. Check the electrolyte level. It should be up to the indicator ring. If necessary, add distilled water.
11. Lower the solution tank.

Machines equipped with onboard Charger:

1. Fully open Recovery Tank / Battery Cover or prop in partially open position using bracket (included). This will provide additional venting of batteries during charging cycle.
2. Connect charger's AC power cord to AC mains. The charger's YELLOW "AC" LED will light.

Note: When charger is energized, all machine function will shut down.

3. After several seconds, the charger's green LED will flash to indicate that charging is in process.

Note: If no lights are illuminated, or yellow LED flashes, refer to the charger Product Manual Troubleshooting section.

4. When charging is complete, both the yellow and the green LED's will remain on. The charger is now in standby mode.
5. Disconnect charger's AC power cord.
6. Raise battery cover and check the battery electrolyte level. It should be up to the indicator ring. If necessary, add distilled water.
7. Lower the battery cover.

Note: For additional information about battery charger function, please see the charger Product Manual.

MAINTENANCE-From Serial Number **

ON-BOARD CHARGER BATTERY SELECTION



Disconnect charger from wall outlet before changing charge profiles. Failing to do so could result in electrical shock.

DIPSWITCH: SW1

Charging Curve Table

DP1	DP2	CHARGING CURVE
ON	OFF	IU1a-ACD-for Wet batteries (default setting)
ON	ON	IU1a-O AGM-for AGM or Gel batteries (maintenance free)

Dipswitches are located behind the label on the front of the charger. Peel the top right corner back to reveal two sets of dipswitches.



Only dipswitch SW1 effects the charging curve. Select the appropriate dip switch setting from the Charging Curve Table. Do not change settings of SW2. Changing settings of SW2 dipswitch could result in charger failure.

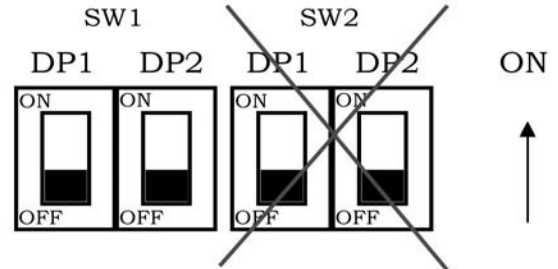

Once the appropriate charger setting has been selected, replace label. To verify charger settings, observe charger immediately after startup. When configured for lead-acid batteries, the red LED will flash twice. If configured for gel/AGM batteries the green LED will flash twice.



**CALL MANUFACTURER FOR SERIAL NUMBER

MAINTENANCE

CHANGING BATTERIES

Stop the machine in a clean area next to the charger. Turn off machine.

FOR SAFETY: Before leaving or servicing the machine; stop on level surface, turn off machine and remove key.

1. Raise the solution tank.
2. Engage solution tank support arm.
3. Disconnect battery pack from machine.
4. Use the proper size open end wrench to disconnect main ground wire first and secure cable terminal away from batteries.
5. Disconnect main positive lead and secure cable terminals away from batteries.
6. Loosen both terminals on jumper cable and remove.
7. Prepare a suitable site to place the batteries.
8. Attach suitable battery lifting device and lift batteries from the machine.



Batteries are a potential environmental hazard. Consult your battery supplier for safe disposal methods.

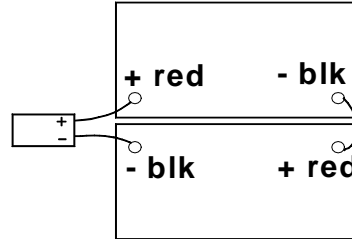

SCRUB BRUSHES

NOTE: All original equipment brushes are equipped with "Perform Alert®". This feature will tell the operator when it is time to replace the scrub brush. "Perform Alert®" brushes have pre-trimmed bright yellow tufts to indicate the length of a worn out brush. When the tufts in the scrub brush wear to a length equal to the yellow tufts, the scrub brush should be replaced.

There are five different types of brushes available to cover applications from cleaning heavily soiled floors to polishing. A pad driver is also available to take advantage of the many cleaning pads on the market and further add to the flexibility of the Saber Compact. Please refer to the following to assist in selecting the proper brush or pad for the work at hand.

UNCOATED FLOORS

Aggressive Grit is a nylon fiber impregnated with silicone carbide grit. It grinds away stain, soil, and removes surface material.

Mild Grit is a less aggressive silicone carbide grit suitable for cleaning medium soil conditions. Advantages are faster ground speed than nylon bristles on light solid applications.

Nylon is a general-purpose scrub brush with stiff bristles. Polypropylene works well for maintaining concrete, wood and tile floors.

FINISHED FLOORS

Nylon Polish is the softest brush. It will gently clean finished tile or terrazzo floors without removing floor finish or floor material. Used for washing highly polished or burnished floors.

Nylon bristles are used in a variety of applications on coated or uncoated surfaces.

White Pads (Polishing) are used for dry polishing to achieve a high-gloss appearance, or surface washing on highly polished or burnished floors.

Red Pads (Buffing) are used for light-duty scrubbing. When used with a mild detergent they will provide surface cleaning without removing the finish.

Blue Pads (Scrubbing) are used for heavy-duty scrubbing and light stripping. The blue pads remove less finish than brown stripping pads, yet will remove black marks, stains and dirt.

Brown Pads (Stripping) are used for easy and complete removal of old floor waxes/finishes. They will quickly remove ground in dirt, black heel marks, and spills. When used with the proper stripper, this pad leaves the floor clean and ready for finishing.

The scrub brush should be checked before each days work for wire, string, wear and damage. The scrub brush should be replaced if brush bristles are missing or if yellow Perform Alert © indicates minimum brush length.

REPLACING OR INSTALLING SCRUB BRUSHES

1. With the scrub deck up, turn the machine power off.

FOR SAFETY: Before leaving or servicing the machine; stop on level surface, turn OFF machine and remove key.

2. Locate release lever on top of brush or pad driver. Rotate release lever counter-clockwise and the brush/pad driver will release and drop down.
3. To reinstall, center the brush driver under the brush drive hub. Raise until it contacts brush driver assembly. Turn clockwise until release lever plate locks into position.

NOTE: Check that release plate is completely closed and pad/brush is securely attached. Damage to driver or brush could occur.

MAINTENANCE

SQUEEGEE BLADES

The front squeegee blade allows solution to pass through channels in the blade into the squeegee assembly while maintaining vacuum to provide lift.

The rear blade wipes the floor to a near dry condition. It is important the rear blade be in good condition to properly do its job.

Check both the front and rear squeegee blades for damage and wear each day in the pre-run check. Change the front blade if it is torn or has an uneven edge. Change the rear blade if it is less than 1/2 the original thickness.

TO REMOVE SQUEEGEE ASSEMBLY

1. With the squeegee in the up position, turn the machine power off.
2. Loosen both squeegee knobs and pull squeegee assembly rearward from the lifting carrier.
3. Inspect or repair as necessary and reinstall.

TO REPLACE SQUEEGEE BLADES

1. With the squeegee in the up position, turn the machine power off.

FOR SAFETY: Before leaving or servicing machine; stop on level surface, turn off machine and remove key.

2. Remove the squeegee assembly from the machine. Remove all screws and remove blade retainer strap and remove squeegee blade.
3. Replace squeegee blades as required.
4. Install blade with ribbed surface facing out.
5. Install squeegee retainer strap.
6. Install all screws starting from center and working to ends.

DELUXE SQUEEGEE BLADES

The front squeegee blade allows solution to pass through channels in the blade into the squeegee assembly while maintaining vacuum to provide lift. The front blade has four wear surfaces and can be rotated for extended life. The front blade should not require regular replacement under normal use.

The rear blade wipes the floor to a near dry condition. It is important the rear blade be in good condition to properly do its job. Each rear squeegee blade has four wear surfaces for extended service.

Check both the front and rear squeegee blades for damage, wear, and adjustment each day in the pre-run check. Change the front blade if it is torn or has an uneven edge. Change the rear blade if it is less than 1/2 the original thickness.

ADJUSTING DELUXE SQUEEGEE

Adjusting the squeegee is a two-part process. First, the squeegee assembly must have correct pitch in order for the squeegee blade to have the same deflection at each tip as well as the center. The knob on the squeegee linkage controls the pitch adjustment. The second adjustment is the deflection.

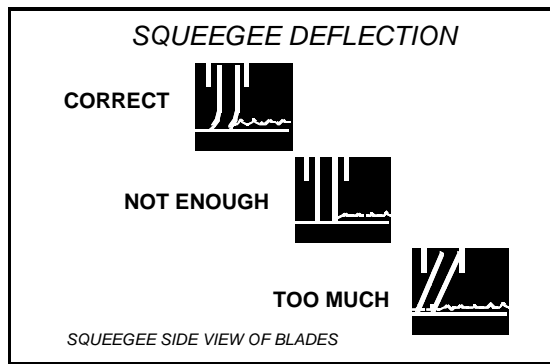
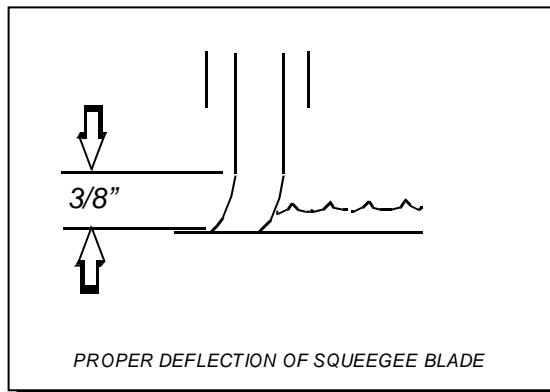

TO ADJUST SQUEEGEE PITCH

1. Choose a smooth, level surface. Turn "ON" the key switch and vacuum switch. Lower the squeegee and drive forward at least 2 feet (60cm.).
2. With the squeegee down, stop the machine. Do not allow machine to roll back.

FOR SAFETY: Before leaving or servicing the machine, stop on level surface, turn off machine and remove key.

3. Determine the differences, if any, in deflection of the squeegee blade between each end and the middle. Proper adjustment is obtained when deflection is equal all the way across the squeegee blade.
4. To decrease the deflection of the squeegee blade at the ends, adjust plastic knobs at the far right or left of squeegee assembly.
5. Check the deflection of the squeegee blades again. Repeat steps 1 through 4 until the deflection is equal across the entire rear squeegee blade.

TO ADJUST AMOUNT OF REAR SQUEEGEE DEFLECTION

1. Choose a smooth, level surface. Turn "ON" the key switch and vacuum switch. Lower the squeegee and drive forward at least 2 feet (60cm.).
2. With the squeegee down, stop the machine. Do not allow machine to roll back.

FOR SAFETY: Before leaving or servicing machine, stop on level surface, turn off machine and remove key.

3. Observe the amount of squeegee deflection. It should deflect approximately 3/8 in. (9.5mm) across the entire width of the squeegee.
4. To increase the squeegee deflection, turn the center knob above the lift carrier bracket clockwise. To decrease the deflection, turn the knob counterclockwise.

NOTE: The deflection should be consistent along the length of the squeegee. If the deflection varies from end to end the knobs can be adjusted independently to correct the variation.

5. Turn on the key switch. Raise, then lower squeegee assembly. Drive forward at least 2 feet (60cm.).
6. Repeat steps 2 through 4 until deflection of approximately 3/8 in. (9.5mm) is reached.

TO REPLACE OR ROTATE REAR SQUEEGEE BLADE

1. With the squeegee in the up position, turn key switch "OFF".

FOR SAFETY: Before leaving or servicing machine; stop on level surface, turn off machine and remove key.

2. Remove the squeegee assembly from the machine. Unlatch and remove blade retainer strap and remove squeegee blade.
3. Rotate the squeegee to new edge position or replace as required. Each blade has four edge positions.
4. Install blade on locating tabs of squeegee assembly.
5. Install squeegee retainer strap.
6. Fasten and lock latch, adjust latch only tight enough to take up slack in retaining strap.

TO REPLACE OR ROTATE FRONT SQUEEGEE BLADE

1. With the squeegee in the up position, turn key switch "OFF".
2. Remove the squeegee from the machine. Loosen (3) thumb screws securing retainer strap.
3. Remove front retainer strap.
4. Remove squeegee's blade from locating tabs on squeegee assembly and rotate to new position or replace as required.
5. Install blade on locating tabs of squeegee tool.
6. Replace front retainer strap.
7. Secure strap by tighten (3) thumb screws.

GREASING AXLES

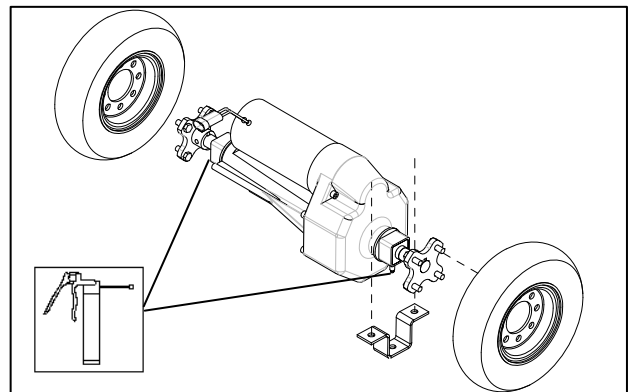

1. Apply 1-2 strokes of MOBILTEMP®78 or compatible clay-based or calcium-based grease per service schedule.

MAINTENANCE

SERVICE SCHEDULE

MAINTENANCE	DAILY	WEEKLY	MONTHLY	100 HRS	200 HRS
Check batteries after charging; add water if necessary	*				
Check pad wear to prevent buildup of chemicals	*				
Check linkages and connectors for wear and damage	*				
Check hoses for wear, blockages, or damage	*				
Clean squeegee; check for adjustment; inspect for wear	*				
Check handles, switches, knobs, domes, and gaskets for damage	*				
Clean out recovery tank	*				
Clean out solution tank; remove and clean screen	*				
Clean outside of all tanks; check for damage	*				
Run vac motor for at least one minute to allow motor to dry	*				
Store with dome off tank to allow the tank to dry	*				
Check scrub deck splash skirt		*			
Check batteries for corrosion, cracks and evidence of overheating			*		
Check all bearings for noise			*		
Check all gaskets for wear and leakage			*		
Check vac motor carbon brushes			*		
Check brushes for wear; ensure bristles are not damaged			*		
Check linkages for wear and damage			*		
Grease wheels and casters			*		
Check squeegee blades for wear and frame for damage			*		
Check overall performance of machine			*		
Clean batteries and terminals				*	
Thoroughly clean the machine				*	
Check parking brake (inspect cables, linkages and pulleys)					*
Check carbon brushes in all vacuum, brush drive, and propel motors					*
Blow out dust in motors					*
Inspect motor commutators					*
Clean chains, cables and pulleys					*
Clean pivot points on squeegee and scrub deck linkages					*

MACHINE TROUBLESHOOTING

PROBLEM	CAUSE	SOLUTION
Poor or no water pick-up	Debris caught on squeegee	Remove debris
	Worn squeegee blades	Replace squeegee blades
	Vacuum hose clogged	Clear obstruction from hose
	Vacuum hose disconnected from squeegee or recovery tank	Reconnect vacuum hose
	Vacuum hose damaged	Replace vacuum hose
	Vacuum motor inlet screen dirty	Clean inlet screen
	Recovery tank not sealed	Check vacuum motor position. Replace damaged seal.
	Foam filling recovery tank	Empty recovery tank Use less or different detergent Use defoamer
Vacuum motor does not run, or runs slowly	Recovery tank full	Drain recovery tank
	Circuit breaker tripped	Reset circuit breaker
	Loose connection	Check motor wires and connections
	Faulty vacuum contractor	Replace contactor
	Worn vacuum motor brushes	Replace brushes, check commutator
Poor scrubbing performance	Debris caught in scrub brush	Remove debris
	Worn brush or pad	Replace brush or pad
	Improper detergent, brush or pad used	Contact equipment or application specialist
	Low scrub brush down pressure	Increase brush pressure (traction model only)
	Low battery charge	Charge batteries
Brush motor does not run, or runs slowly	Circuit breaker tripped	Reset circuit breaker
	Loose connection	Check motor wires and connection
	Faulty brush motor contactor	Replace contactor
	Worn brush motor brushes	Replace brushes, check commutator

MACHINE TROUBLESHOOTING

PROBLEM	CAUSE	SOLUTION
Little or no solution flow to the floor	Solution tank empty	Fill solution tank
	Solution flow turned off or set too low	Turn on or increase flow setting
	Solution strainer plugged	Clean solution strainer
	Solution hoses obstructed	Clear obstruction from hose
	Solution solenoid valve obstructed or stuck (traction model only)	Clean or replace
No power to machine	Battery disconnected	Check all battery cable connections
	Emergency shut-off activated (traction model only)	Reset
	Battery connections corroded	Clean connections
	Faulty main contactor	Replace contactor
	Faulty power switch	Replace switch
Little or no propel (traction model only)	Low battery charge	Charge batteries
	Machine turned on with directional control button(s) not in neutral	Allow control button to return to neutral. Restart
	Controller overheated	Allow cool down period
	Loose connection	Check motor wires and connection

SABER
COMPACT[™]
PARTS

CONTROL HANDLE GROUP - NON-TRACTION

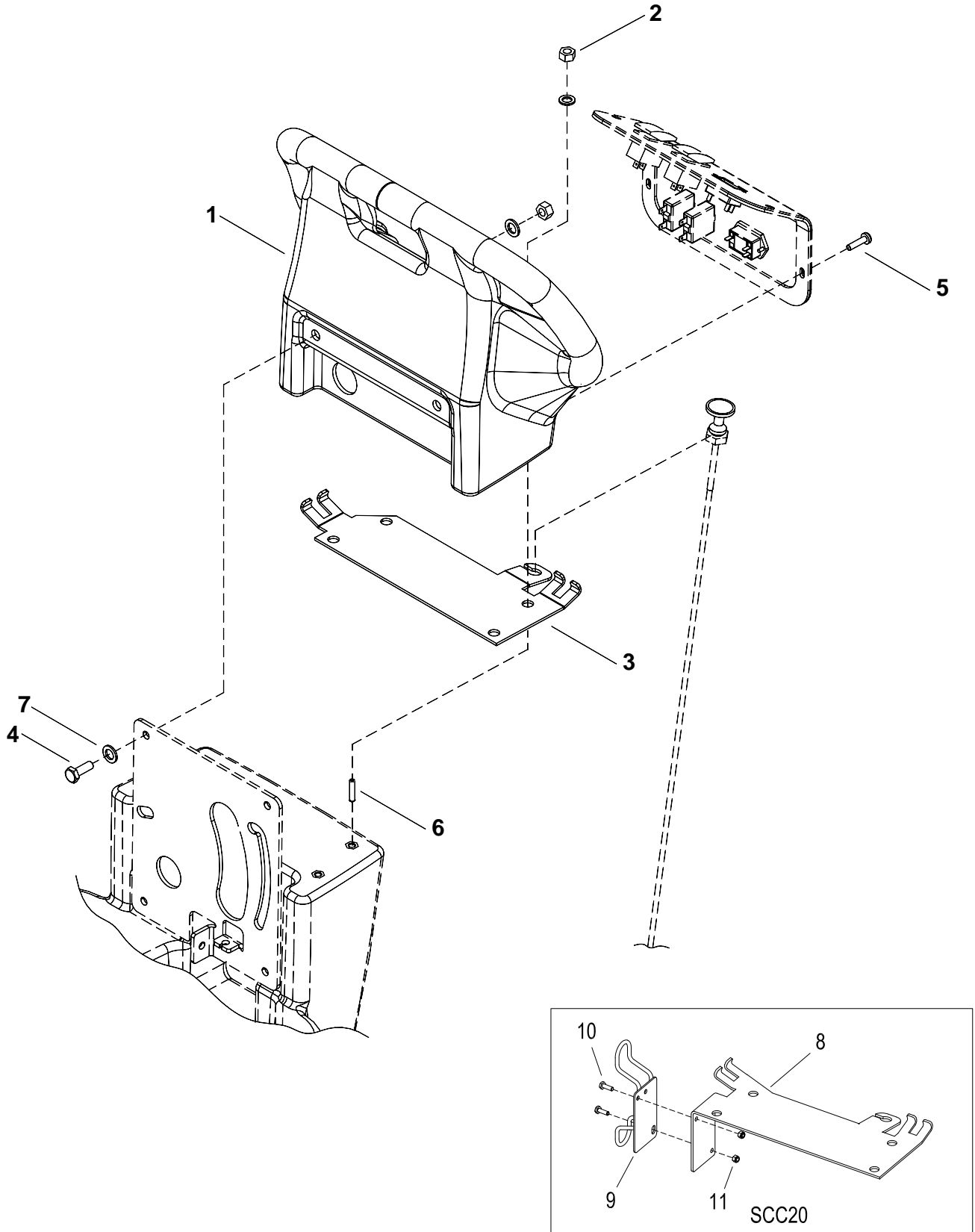

CONTROL HANDLE GROUP – NON TRACTION

REF	PART NO.	PRV NO.	QTY	DESCRIPTION	SERIAL NO. FROM	NOTES:
1	86031740	27861	1	CONSOLE, HANDLE		
2	86005750	57113	6	NUT, 5/16-18 HEX NYLOCK		
3	86081960	62865	1	PLATE, DRAIN HOSE		
4	86006750	70302	2	SCR, 5/16-18 X 1"HHCSGR5PLT DL		
5	86006950	70532	4	SCR, 10-32 X 1/2 PPHMS BLK NP		
6	86278110	81491	4	SET SCR, 5/16-18 X1.5 CP SS DL		
7	86010670	87029	8	WASHER, 5/16 FLAT SS		
8	86079370	620108	1	PLATE, DRAIN HOSE OBC		
9	86218800	41540	1	HANGER, CHARGER CORD 172		
10	86277700	70944	2	SCR, 10-32 X 3/8" PTHMS BLK		
11	86005700	57104	2	NUT, 10-32 W/STAR WASHER PLTD		

CONTROL HANDLE GROUP - TRACTION

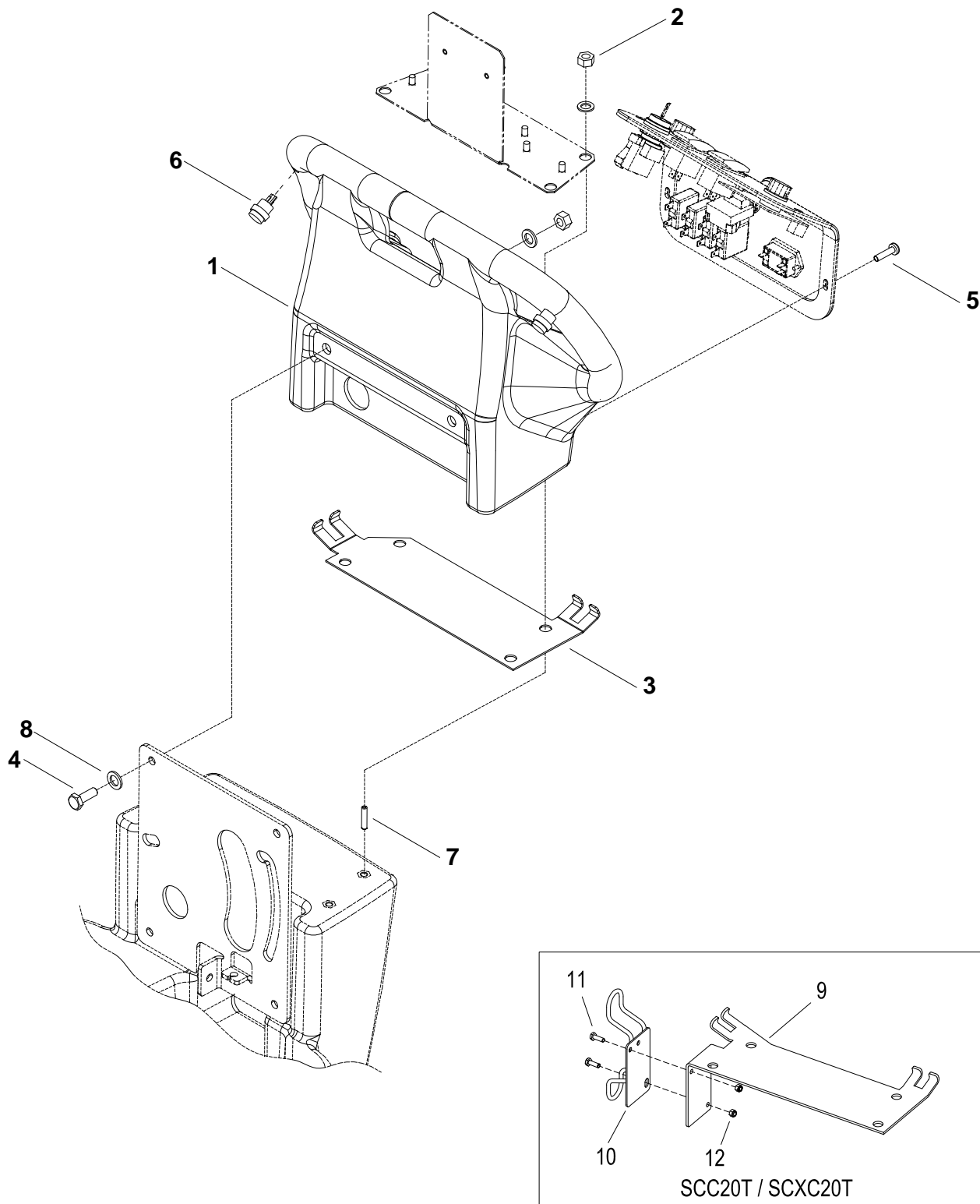

CONTROL HANDLE GROUP - TRACTION

REF	PART NO.	PRV NO.	QTY	DESCRIPTION	SERIAL NO. FROM	NOTES:
1	86351330	27891	1	CONSOLE, HANDLE PROPEL		
2	86005750	57113	6	NUT, 5/16-18 HEX NYLOCK		
3	86081900	62854	1	PLATE, DRAIN HOSE		
4	86006750	70302	2	SCR, 5/16-18 X 1"HHCSGR5PLT DL		
5	86006950	70532	4	SCR, 10-32 X 1/2 PPHMS BLK NP		
6	86007220	72166	2	SWITCH, SPST MOMENTARY		
7	86278110	81491	4	SET SCR, 5/16-18 X1.5 CP SS DL		
8	86010670	87029	8	WASHER, 5/16 FLAT SS		
9	86079360	620107	1	PLATE, DRAIN HOSE OBC TRAC		
10	86218800	41540	1	HANGER, CHARGER CORD 172		
11	86277700	70944	2	SCR, 10-32 X 3/8" PTHMS BLK		
12	86005700	57104	2	NUT, 10-32 W/STAR WASHER PLTD		

DECAL GROUP

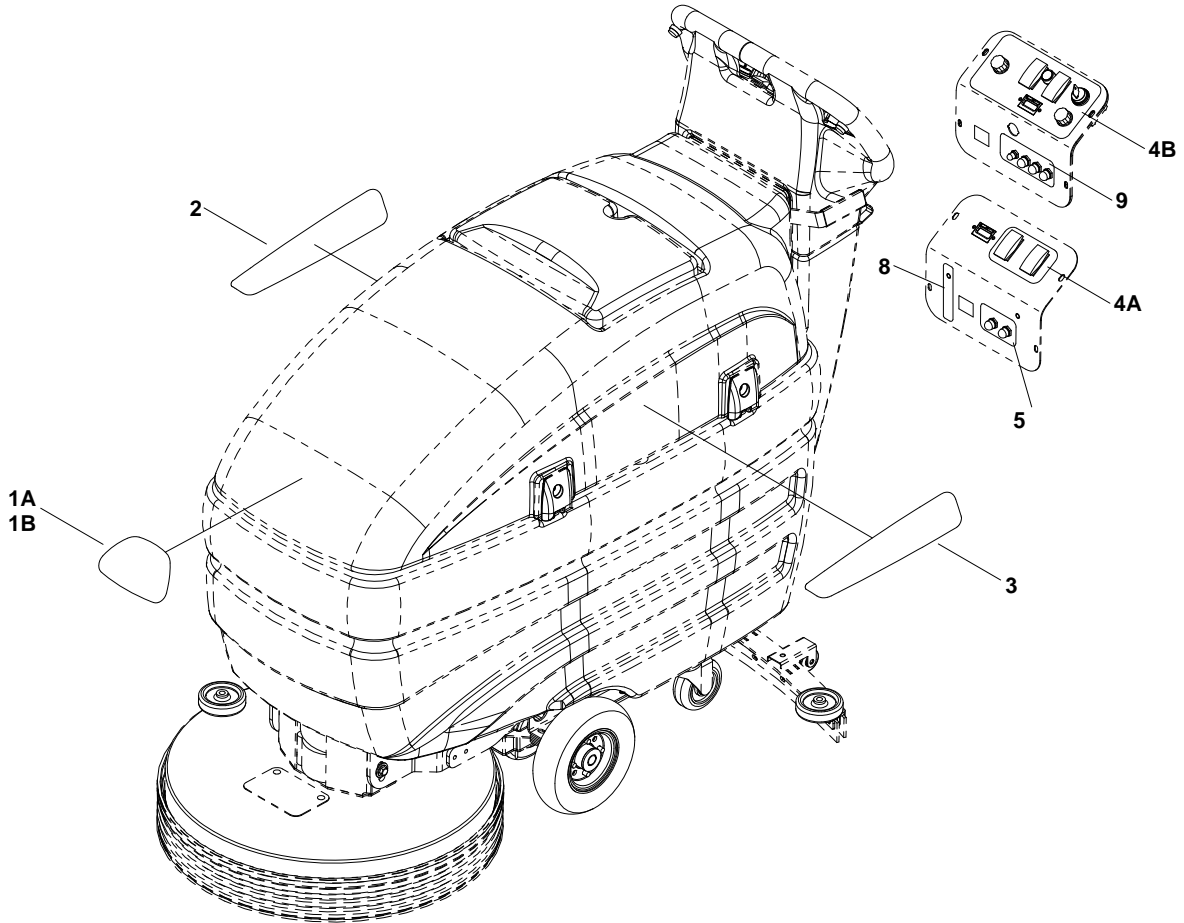

DECAL GROUP

REF	PART NO.	PRV NO.	QTY	DESCRIPTION	SERIAL NO. FROM	NOTES:
1A	86004970	50990	1	LABEL, WINDSOR LOGO DOMED		
1B	86245910	50991	1	LABEL, QUADRA LOGO DOMED		
2	86259210	500142	1	LABEL, MAIN (RIGHT)		
3	86242650	500143	1	LABEL, MAIN (LEFT)		
4A	86242670	500145	1	LABEL, CONTROL PANEL		NON-TRACTION
4B	86242660	500144	1	LABEL, CONTROL PANEL		TRACTION
5	86242940	500245	1	LABEL, CIRCUIT BREAKER 2.4L	*(1)	NON-TRACTION
6	OPEN	-	-	OPEN		
7	OPEN	-	-	OPEN		
8	86242850	500213	1	LABEL, SOLUTION		NON-TRACTION
9	86242930	500244	1	LABEL, CIRCUIT BREAKER W/ HM	*(1)	TRACTION

* SEE SERIAL NUMBER PAGE

NOTE: SEE "SAFETY LABEL LOCATION" PAGE FOR SAFETY LABEL INFORMATION.

ELECTRICAL PANEL GROUP – NON-TRACTION

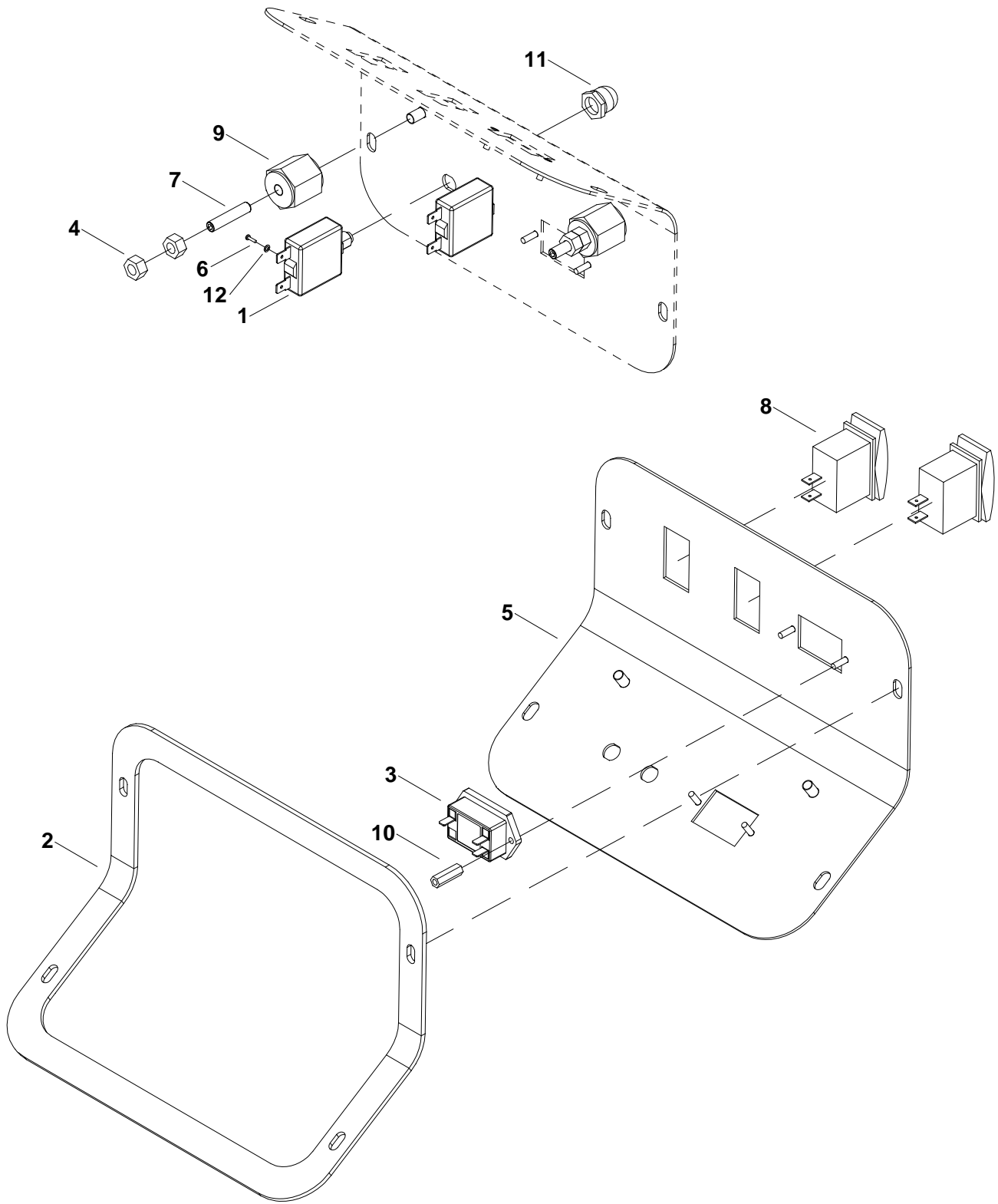

ELECTRICAL PANEL GROUP - NON-TRACTION

REF	PART NO.	PRV NO.	QTY	DESCRIPTION	SERIAL NO. FROM	NOTES:
1	86001910	14606	2	BREAKER, 30A 50VDC CIRCUIT		
2	86237720	35246	1	GASKET, ELECTRICAL PANEL		
3	86005520	54145	1	METER,24V BATTERY CHARGE LEVEL		
4	86077640	57105	4	NUT, 1/4-20 HEX W/STAR WASHER		
5	86081890	62849	1	PLATE, ELECTRICAL PANEL		
6	86273990	70067	4	SCR, 6-32 X 3/8 PPHMS SS		
7	86006850	70393	2	SET SCR, 1/4-20X 1.25L		
8	86007140	72130	2	SWITCH, SPST 2-POSITION ROCKER		
9	86255910	73659	2	STANDOFF, 1/4-20 X 1.0 HEX INS		
10	86255920	73811	2	STANDOFF, 6-32 X 1/2 HEX NYL		
11	86008900	80845	2	BOOT, SEAL-PUSH BUTTON 7/16-28		
12	86279300	87134	4	WASHER, #6 LOCK		

ELECTRICAL PANEL GROUP - TRACTION

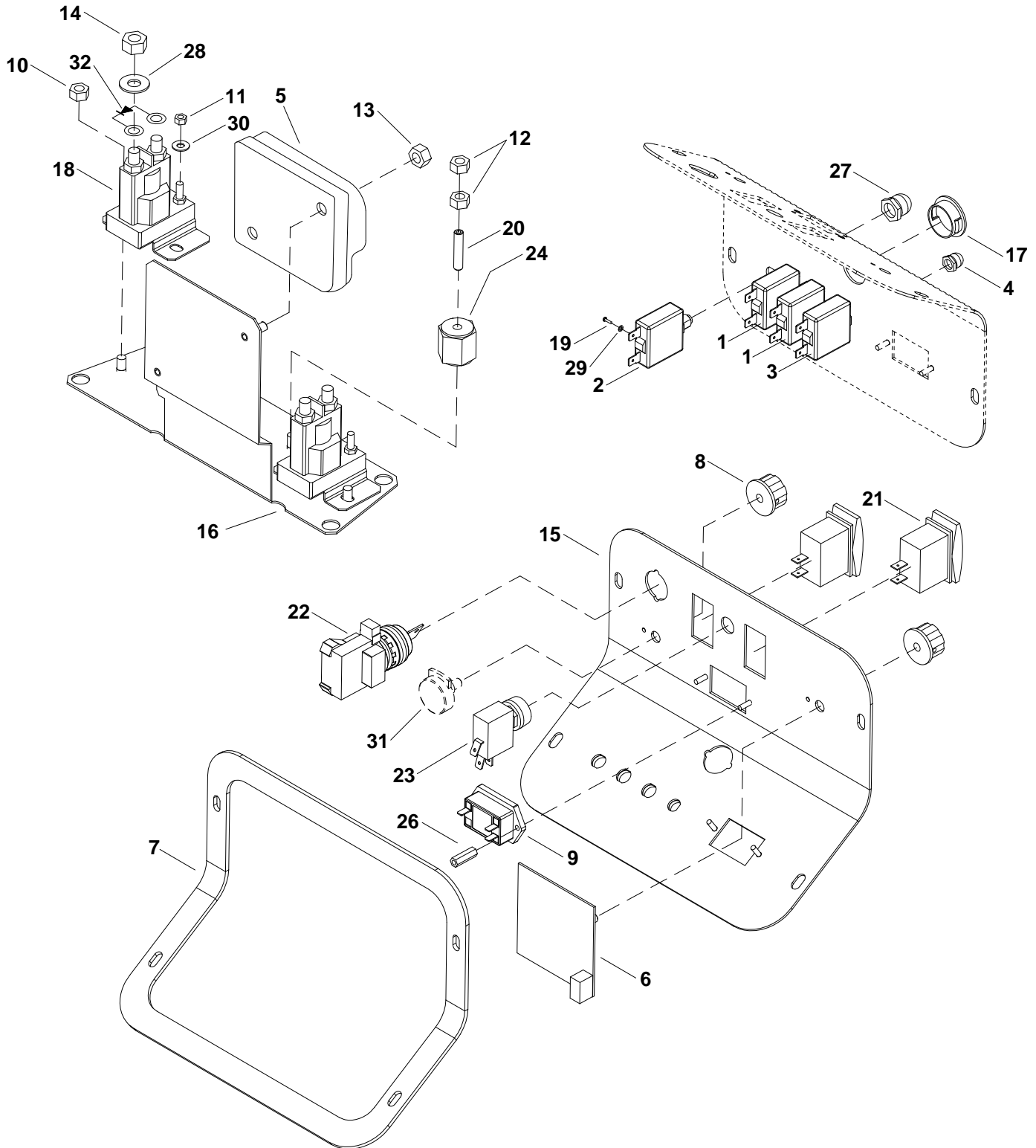

ELECTRICAL PANEL GROUP - TRACTION

REF	PART NO.	PRV NO.	QTY	DESCRIPTION	SERIAL NO. FROM	NOTES:
1	86001910	14606	2	BREAKER, 30A 50VDC CIRCUIT		
2	86001920	14607	1	BREAKER, 25A 50VDC CIRCUIT		
3	86002000	14717	1	BREAKER, 3 AMP		
4	86002010	14942	1	BOOT, 3/8 CIRCUIT BREAKER		
5	86002740	270087	1	CONTROLLER, CURTIS 1210 24V 45A	*(2)	
6	86002720	270077	1	CIRCUIT BOARD, SOLUTION	**	WAS 27858
7	86237720	35246	1	GASKET, ELECTRICAL PANEL		
8	86004850	48072	2	KNOB, 1.06OD X .25ID W/SET SCR		
9	86005520	54145	1	METER, 24V BATTERY CHARGE LEVEL		
10	86005680	57047	4	NUT, 1/4-20 HEX NYLOCK		
11	86005700	57104	4	NUT, 10-32 W/STAR WASHER PLTD		
12	86005710	57105	2	NUT, 1/4-20 HEX W/STAR WASHER		
13	86005720	57106	2	NUT, 8-32 W/STAR WASHER PLTD		
14	86271170	57138	4	NUT, 5/16-18 JAM		
15	86081740	62826	1	PLATE, ELECTRICAL PANEL		
16	86005880	620051	1	PLATE, ELECTRICAL MOUNT	*(2)	
17	86250160	66321	1	PLUG, .875 HOLE		
18	86006360	67118	2	RELAY, 24VDC SOLENOID		
19	86273990	70067	6	SCR, 6-32 X 3/8 PPHMS SS		
20	86006850	70393	1	SET SCR, 1/4-20X 1.25L		
21	86007140	72130	2	SWITCH, SPST 2-POSITION ROCKER		
22	86007170	72159	1	SWITCH KEY TWO POSITION		
	86004860	48073	-	KEY, SWITCH		(NOT SHOWN)
23	86257030	72168	1	SWITCH, MOMENTARY, DPST		
24	86255910	73659	1	STANDOFF, 1/4-20 X 1.0 HEX INS		
25	-	OPEN	-	-		
26	86255920	73811	2	STANDOFF, 6-32 X 1/2 HEX NYL		
27	86008900	80845	3	BOOT, SEAL-PUSH BUTTON 7/16-28		
28	86279130	87083	4	WASHER, 5/16 SPLIT LOCK PLTD		
29	86279300	87134	6	WASHER, #6 LOCK		
30	86279470	87165	4	WASHER, #10 SPLIT LOCK PLTD		
31	86006310	66335	1	POTENTIOMETER, 50K OHMS		SERVICE ITEM
32	86003410	29215	1	DIODE ASM, 76075 X 76075		

* SEE SERIAL NUMBER PAGE

** CALL MANUFACTURER FOR SERIAL NUMBER

HOUR METER

NON-TRACTION

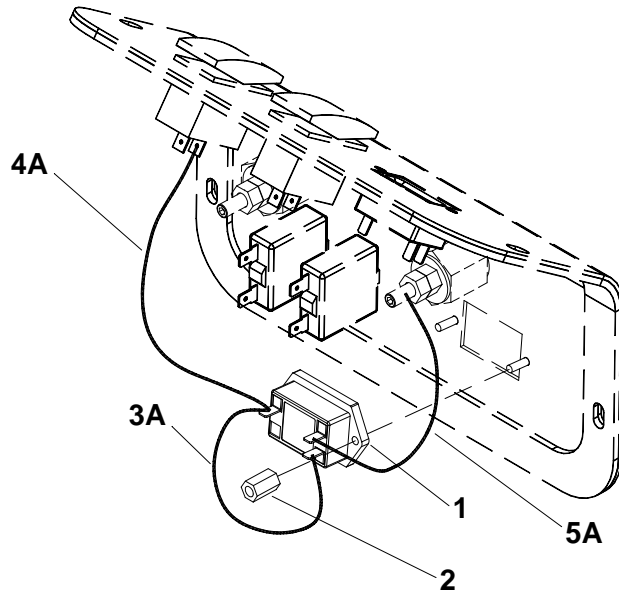

TRACTION

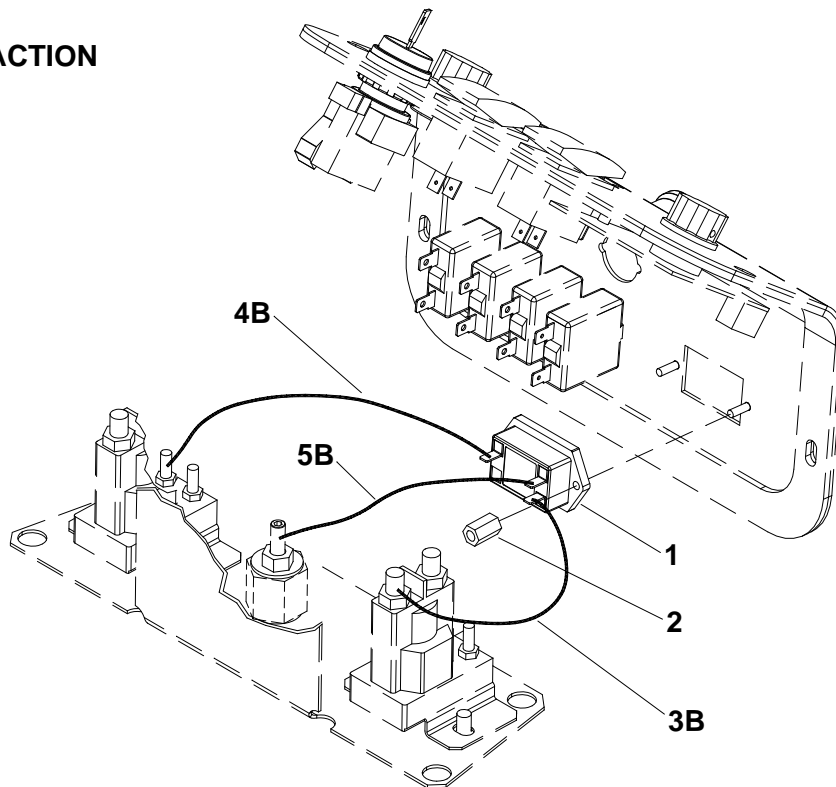

HOURL METER

REF	PART NO.	PRV NO.	QTY	DESCRIPTION	SERIAL NO. FROM	NOTES:
1	86005530	54154	1	METER, 12-48 VDC LED HOUR	*(1)	
2	86255920	73811	2	STANDOFF, 6-32 X 1/2 HEX NYL		
3A	86268650	88490	1	WIRE, 4" RED/18 76040 X 76040		NON-TRACTION
3B	86267340	880269	1	WIRE, 22" RED/18 76075 X 76040		TRACTION
4A	86266840	880075	1	WIRE, 8" RED/18 76031 X 76031		NON-TRACTION
4B	86267350	880270	1	WIRE, 14" RED/18 76008 X 76040		TRACTION
5A	86266690	880034	1	WIRE, 6" BLK/18 76011 X 76040		NON-TRACTION
5B	86267360	880271	1	WIRE, 14" BLK/18 76011 X 76040		TRACTION

* SEE SERIAL NUMBER PAGE

RECOVERY TANK GROUP

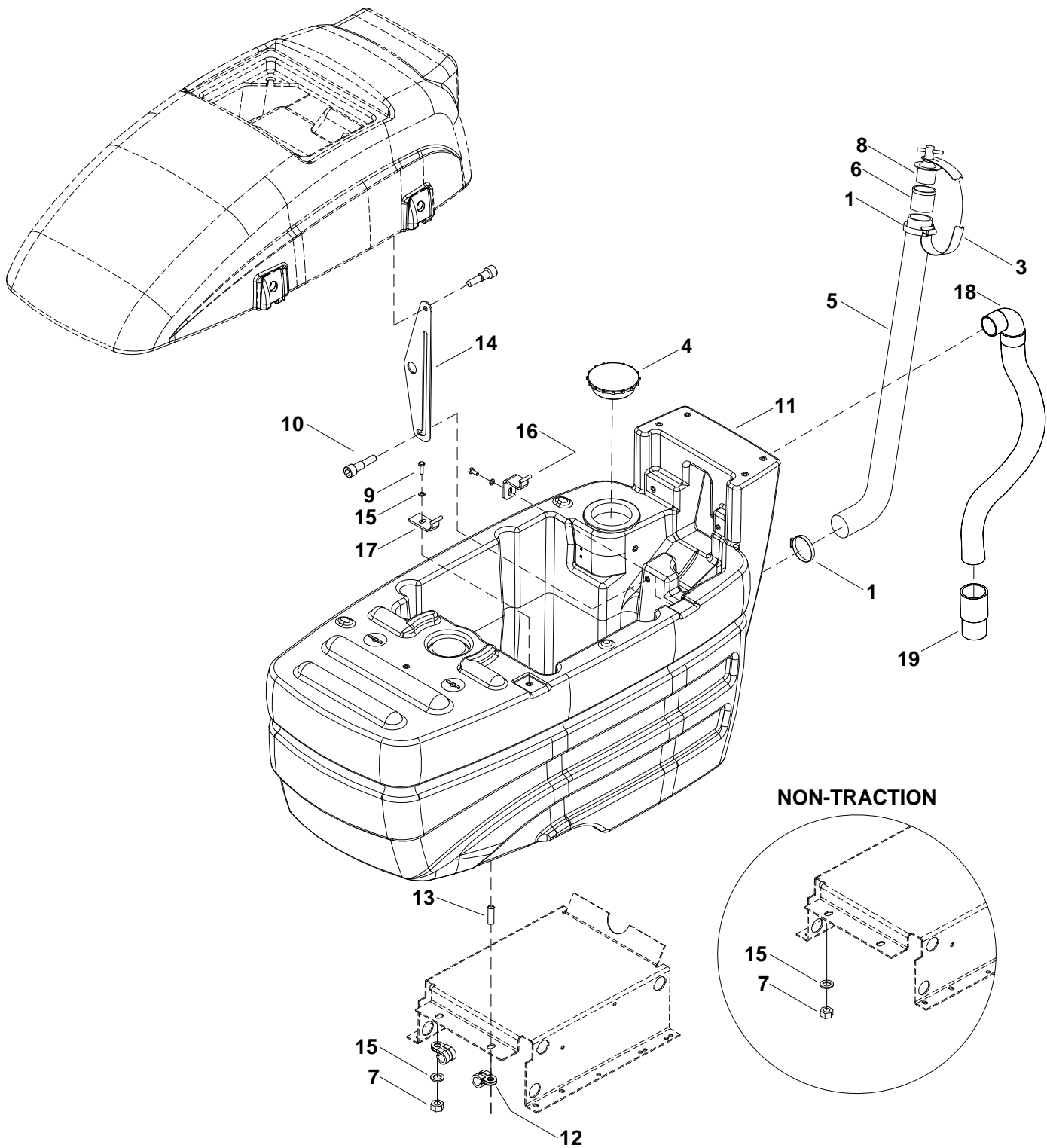

RECOVERY TANK GROUP

REF	PART NO.	PRV NO.	QTY	DESCRIPTION	SERIAL NO. FROM	NOTES:
1	86002400	20064	2	CLAMP, 2" WORM GEAR X .312W		
2	-	OPEN	-	-		
3	86008400	78499	1	TETHER, DRAIN PLUG		
4	86232180	27877	1	CAP, 3 INCH MPT		
5	86004260	39472	1	HOSE, 1.5 X 24.0 DRAIN		
6	86004450	40019	1	HOSEBARB, 1.5 DOUBLE MCHD		
7	86005750	57113	4	NUT, 5/16-18 HEX NYLOCK		
8	86006240	66227	1	PLUG, DRAIN HOSE		
9	86006760	70305	2	SCR, 5/16-18 X 3/4HHCSGR5PLTDL		
10	86278180	70218	2	SHOULDER BOLT, 3/8OD X 1/2L		
11	86008260	75294	1	TANK, RECOVERY		
12	86233410	81270	2	CLAMP, 3/4 DIA CUSHION .406DIA		
13	86278110	81491	4	SET SCR, 5/16-18 X1.5 CP SS DL		
14	86085510	82575	1	PLATE, TANK SUPPORT		
15	86010670	87029	6	WASHER, 5/16 FLAT SS		
16	86096020	89127	1	WLDMNT, HINGE PIN		
17	86095960	89198	1	WELDMENT, HINGE		
18	86004370	39547	1	HOSE ASM, 1.5 BLK VAC X 21		
19	86003010	27759	1	CUFF, HOSE 1.5" BLK A 2161		

SCRUB BRUSH/PAD DRIVER GROUP – 20 IN

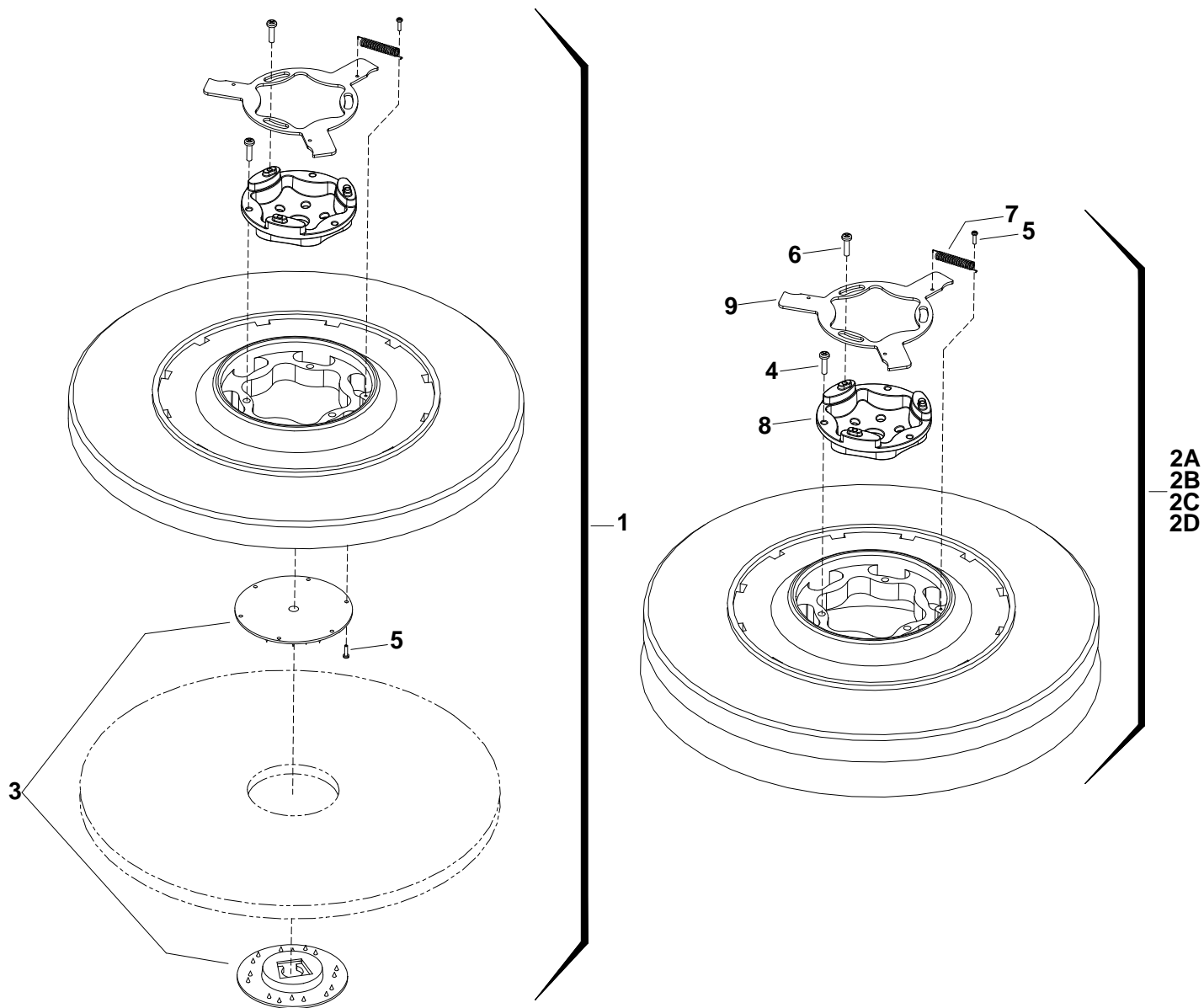

SCRUB BRUSH/PAD DRIVER GROUP - 20 IN

REF	PART NO.	PRV NO.	QTY	DESCRIPTION	SERIAL NO. FROM	NOTES:
1	86000410	02436	-	PAD DRIVER, 20" SD		
2A	86000420	02437	-	BRUSH, 20" POLYPROPYLENE SD		
2B	86000430	02438	-	BRUSH, 20" NYLON SD		
2C	86283870	02439	-	BRUSH, 20" NYLON POLISH SD		
2D	86000440	02440	-	BRUSH, 20" MILD GRIT SD		
3	86005070	51284	-	LOCK, PAD CENTER SNAP, TWO STEP		
4	86276590	70695	-	SCR, 12-24 X 1.0 PPHMS SS		
5	86276580	70694	-	SCR, 8-32 X 3/4 PTHMS		
6	86276600	70696	-	SCR, 10-32 X 3/4 PTHMS		
7	86007910	73817	-	SPRING, EXT .31D X 2.0L X .03W		
8	86007280	730011	-	SOCKET, DRIVE BRUSH		
9	86005940	62852	-	PLATE, BRUSH RELEASE		

SCRUBHEAD GROUP – NON-TRACTION

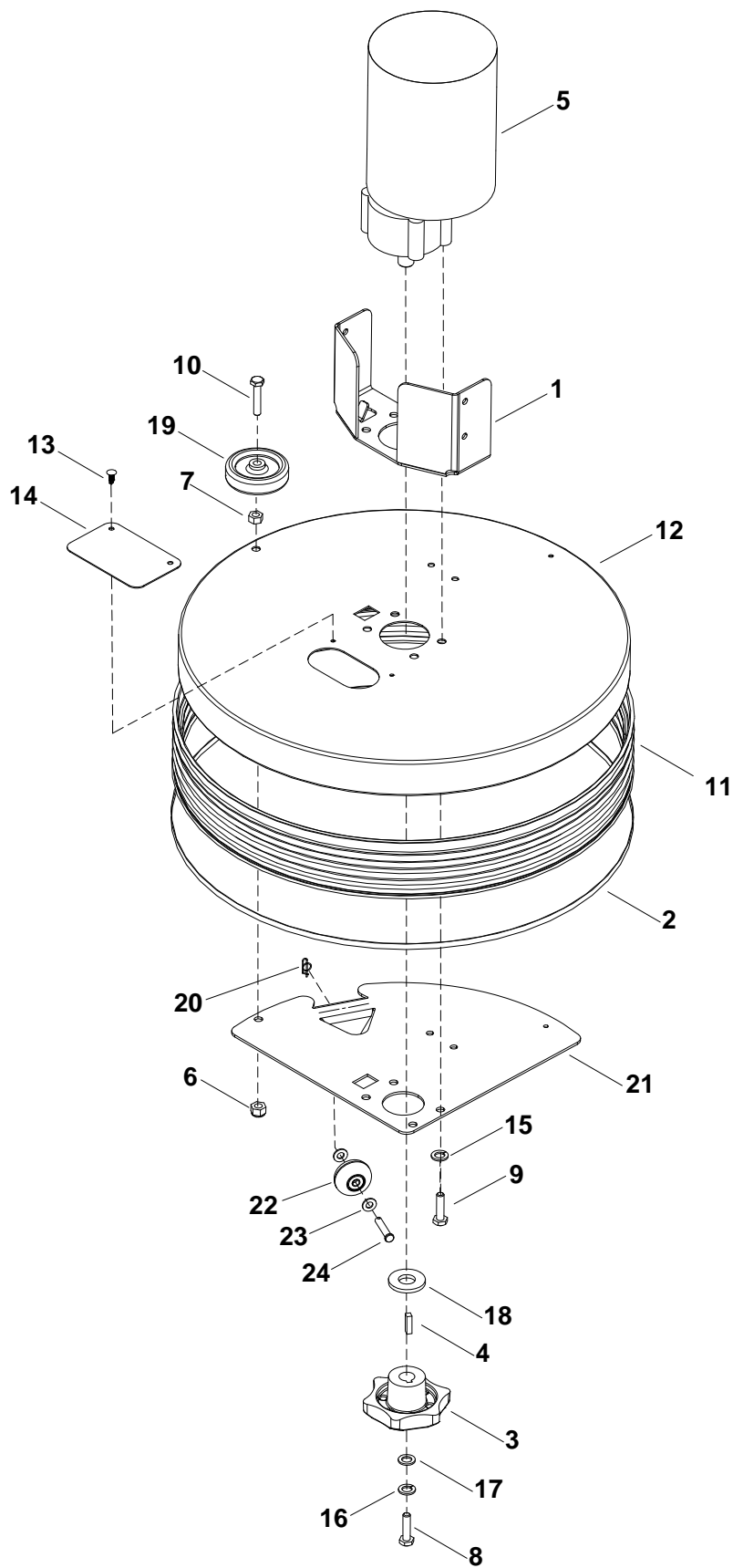

SCRUBHEAD GROUP - NON-TRACTION

REF	PART NO.	PRV NO.	QTY	DESCRIPTION	SERIAL NO. FROM	NOTES:
1	86072330	14357	1	BRKT, DECK MOUNT		
2	86002410	20077	1	CLAMP, WORM #HS356		
3	86003420	29220	1	DRIVER, BRUSH SD		
4	86004810	48040	1	KEY, 1/4 SQ X 1.00		
5	86005320	53630	1	MOTOR ASM, 24VDC 200 RPM GEAR		
	86001970	14695	-	BRUSH SET, BRUSH MOTOR		(NOT SHOWN)
6	86005630	57022	1	NUT, 3/8-16 HEX NYLOCK THIN SS		
7	86005730	57111	1	NUT, 3/8-16 HEX		
8	86007020	70673	1	SCR, 5/16-18 X 1.25 HHCS SS		
9	86006740	70266	4	SCR, 3/8-16 X 1" HHCSGR5PLT DL		
10	86006820	70385	1	SCR, 3/8-16 X 2.0 HHCS GR5 PLT		
11	86253940	730140	1	SKIRT, 3.5 X 57.5" EXT		
12	86253530	730001	1	SHROUD, 20 IN SCRUB DECK		
13	86233560	80805	2	CLIP, TREE .19 HOLE FLAT HEAD		
14	86234800	27899	1	COVER, BRUSH RELEASE 5X6		
15	86278910	87003	4	WASHER, 3/8 ID X 7/8 OD SS		
16	86279130	87083	1	WASHER, 5/16 SPLIT		
17	86279630	87212	1	WASHER, .344IDX1.13ODX.09T PLT		
18	86279640	87213	1	WASHER, .78IDX1.63ODX.25T PLT		
19	86010890	89059	1	WHEEL, SQUEEGEE		
20	86008660	80605	1	COTTER, 5/16" RING		
21	86068380	14402	1	BRKT, BRUSH ASSIST		
22	86011070	89219	1	WHEEL, 1.812ODX.314IDX.952W		
23	86010760	87142	2	WASHER, .344X.69X.066 FLAT PLT		
24	86006270	66276	1	PIN, CLEVIS 5/16 X 1.625 LG		

SCRUBHEAD GROUP – TRACTION

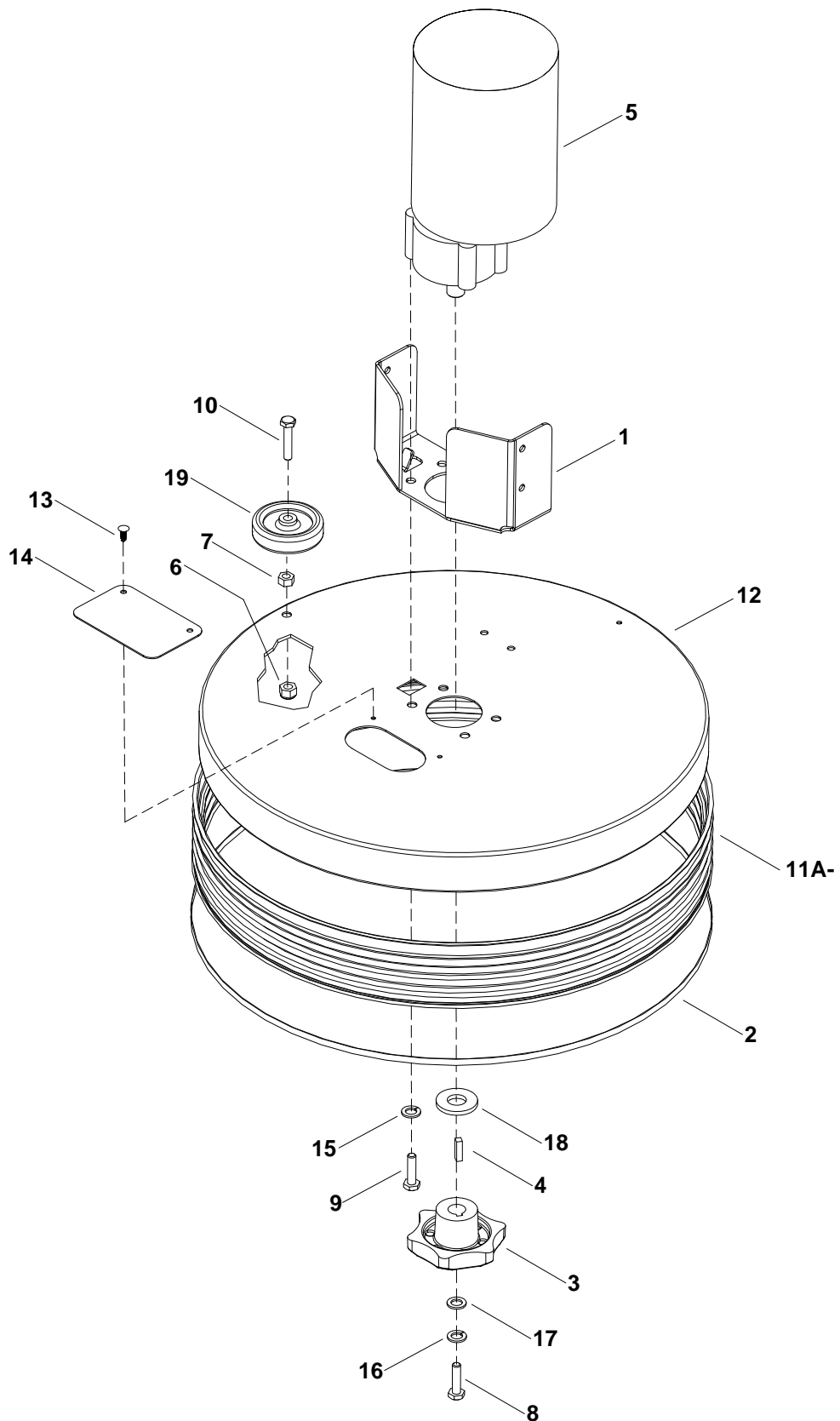

SCRUBHEAD GROUP - TRACTION

REF	PART NO.	PRV NO.	QTY	DESCRIPTION	SERIAL NO. FROM	NOTES:
1	86072330	14357	1	BRKT, DECK MOUNT		
2	86002410	20077	1	CLAMP, WORM #HS356		
3	86003420	29220	1	DRIVER, BRUSH SD		
4	86004810	48040	1	KEY, 1/4 SQ X 1.00		
5	86005320	53630	1	MOTOR ASM, 24VDC 200 RPM GEAR		
	86001970	14695	-	BRUSH SET, BRUSH MOTOR		(NOT SHOWN)
6	86005630	57022	1	NUT, 3/8-16 HEX NYLOCK THIN SS		
7	86005730	57111	1	NUT, 3/8-16 HEX		
8	86007020	70673	1	SCR, 5/16-18 X 1.25 HHCS SS		
9	86006740	70266	4	SCR, 3/8-16 X 1" HHCSGR5PLT DL		
10	86006820	70385	1	SCR, 3/8-16 X 2.0 HHCS GR5 PLT		
11	86253940	730140	1	SKIRT, 3.5 X 57.5" EXT		
12	86253530	730001	1	SHROUD, 20 IN SCRUB DECK		
13	86233560	80805	2	CLIP, TREE .19 HOLE FLAT HEAD		
14	86234800	27899	1	COVER, BRUSH RELEASE 5X6		
15	86278910	87003	4	WASHER, 3/8 ID X 7/8 OD SS		
16	86279130	87083	1	WASHER, 5/16 SPLIT		
17	86279630	87212	1	WASHER, .344IDX1.13ODX.09T PLT		
18	86279640	87213	1	WASHER, .78IDX1.63ODX.25T PLT		
19	86010890	89059	1	WHEEL, SQUEEGEE		

SCRUBHEAD LIFT GROUP – NON TRACTION

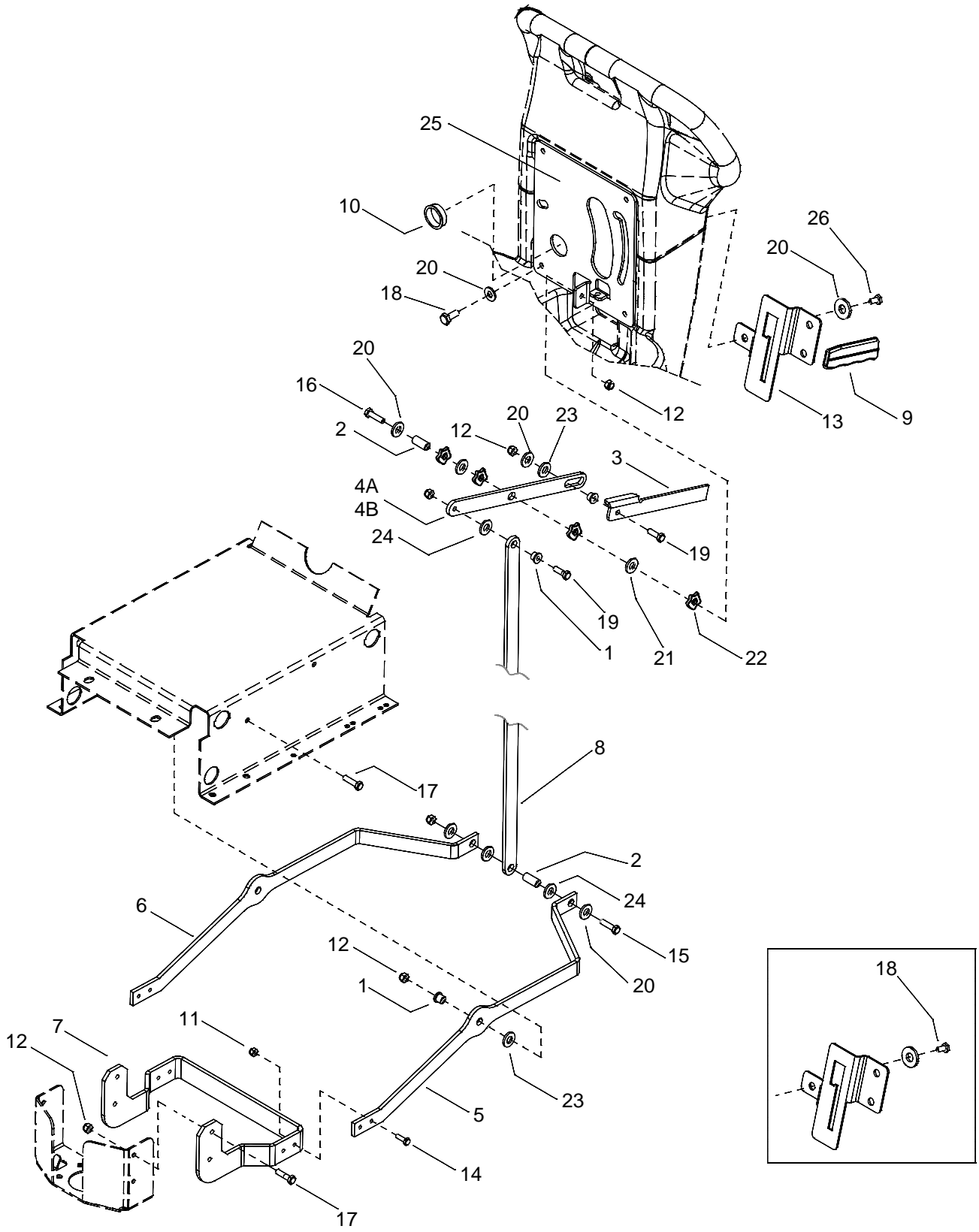

SCRUBHEAD LIFT GROUP – NON-TRACTION

REF	PART NO.	PRV NO.	QTY	DESCRIPTION	SERIAL NO. FROM	NOTES:
1	86228840	09124	4	BEARING, FLANGED.314IDX.502OD		
2	86228880	09132	2	BEARING, .314 ID X .503 OD X 1		
3	86072350	14360	1	BRKT, LIFT LEVER HANDLE		
4A	86072360	14361	1	BRKT, LIFT LEVER		
4B	86073420	149985	1	BRKT, LIFT LEVER OBC		SCC20, SCC20T, SCXC20T
5	86072370	14363	1	BRKT, LIFT LEFT		
6	86072380	14364	1	BRKT, LIFT, RIGHT		
7	86072520	14401	1	BRKT, SCRUB DECK MOUNT		
8	86066960	14362	1	BAR, LINKAGE		
9	86238310	36133	1	GRIP, 3/16" X 1.0" FLAT BAR		
10	86238430	36191	1	GROMMET 1.00 ID 3/16 GRIP		
11	86005680	57047	4	NUT, 1/4-20 HEX NYLOCK		
12	86005750	57113	10	NUT, 5/16-18 HEX NYLOCK		
13	86081880	62848	1	PLATE, SCRUB DECK POSITION		
14	86273810	70018	4	SCR, 1/4-20 X 1 HHCS SS		
15	86274690	70258	1	SCR, 5/16-18 X 1.5 HHCS GR5PLT		
16	86006730	70259	1	SCR, 5/16-18 X 1.75 HHCS PLTD		
17	86006750	70302	6	SCR, 5/16-18 X 1"HHCSGR5PLT DL		
18	86006760	70305	2	SCR, 5/16-18 X 3/4HHCSGR5PLTDL		
19	86274910	70325	2	SCR, 5/16-18 X 1.25HHCS GR5PLT		
20	86010670	87029	9	WASHER, 5/16 FLAT SS		
21	86279320	87136	2	WASHER, .52 I.D. X .875 O.D.SS		
22	86279350	87140	4	WASHER, WAVE 1/2ID X3/4D X.125		
23	86259400	87205	3	WASHER, THRUST.51 ID X 1 ODBRO		
24	86259410	87206	3	WASHER, THRUST.51 ID X1ODX.063		
25	86072340	14358	1	BRKT, TOWER		
26	86275180	70375	3	SCR, 5/16-18 X 1/2 HHCS GR5		

SCRUBHEAD LIFT GROUP - TRACTION

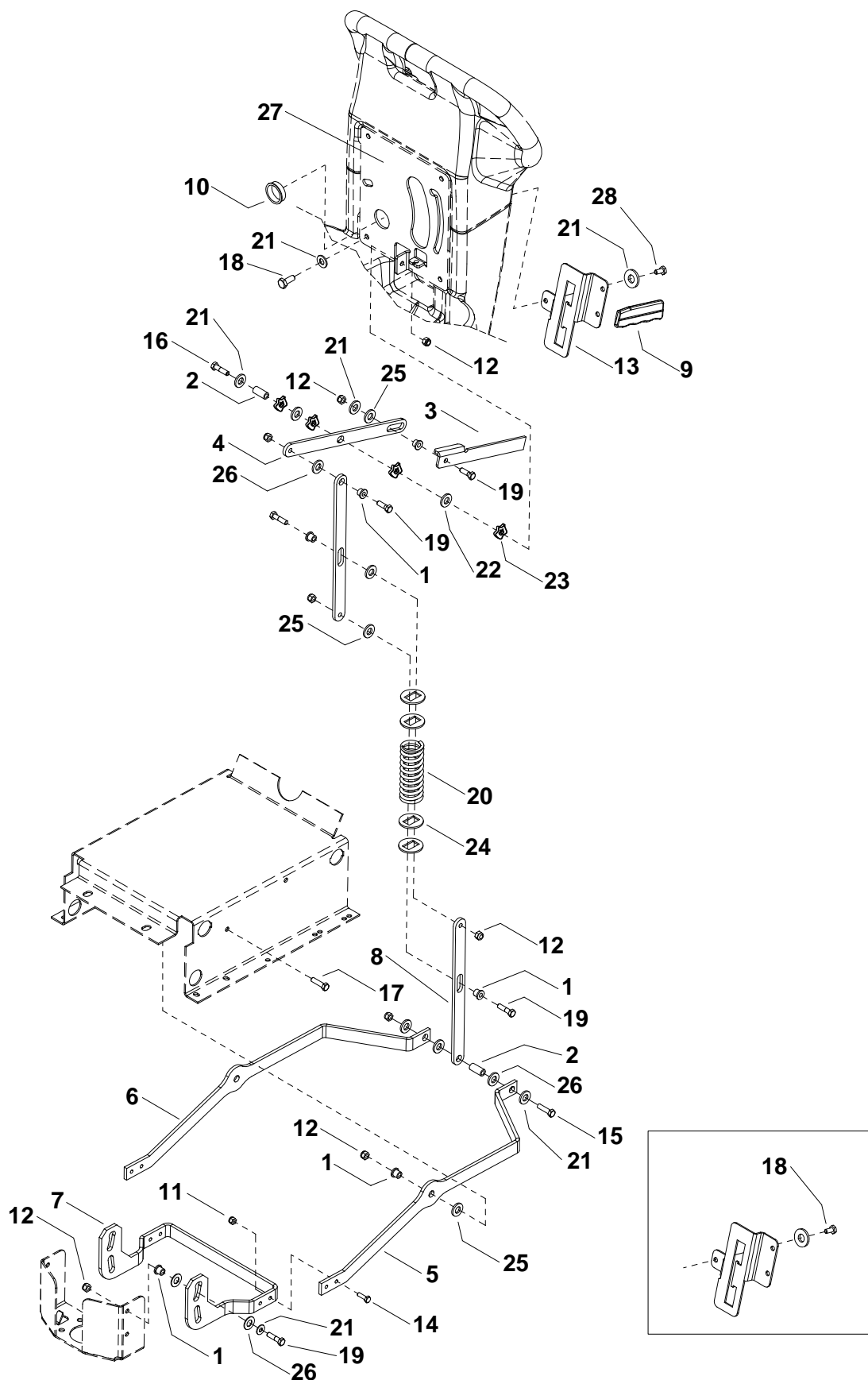

SCRUBHEAD LIFT GROUP - TRACTION

REF	PART NO.	PRV NO.	QTY	DESCRIPTION	SERIAL NO. FROM	NOTES:
1	86228840	09124	10	BEARING, FLANGED.314IDX.502OD		
2	86228880	09132	2	BEARING, .314 ID X .503 OD X 1		
3	86072350	14360	1	BRKT, LIFT LEVER HANDLE		
4	86072360	14361	1	BRKT, LIFT LEVER		
5	86072370	14363	1	BRKT, LIFT LEFT		
6	86072380	14364	1	BRKT, LIFT, RIGHT		
7	86072390	14365	1	BRKT, SCRUB DECK MOUNT		
8	86066970	14370	2	BAR, TENSIONER		
9	86238310	36133	1	GRIP, 3/16" X 1.0" FLAT BAR		
10	86238430	36191	1	GROMMET 1.00 ID 3/16 GRIP		
11	86005680	57047	4	NUT, 1/4-20 HEX NYLOCK		
12	86005750	57113	12	NUT, 5/16-18 HEX NYLOCK		
13	86081760	62828	1	PLATE, SCRUB DECK POSITION		
14	86273810	70018	4	SCR, 1/4-20 X 1 HHCS SS		
15	86274690	70258	1	SCR, 5/16-18 X 1.5 HHCS GR5PLT		
16	86006730	70259	1	SCR, 5/16-18 X 1.75 HHCS PLTD		
17	86006750	70302	2	SCR, 5/16-18 X 1"HHCSGR5PLT DL		
18	86006760	70305	2	SCR, 5/16-18 X 3/4HHCSGR5PLTDL		
19	86274910	70325	8	SCR, 5/16-18 X 1.25HHCS GR5PLT		
20	86254880	730005	1	SPRING,COMP 1.687ODX4.5LX.234W		
21	86010670	87029	13	WASHER, 5/16 FLAT SS		
22	86279320	87136	2	WASHER, .52 I.D. X .875 O.D.SS		
23	86279350	87140	4	WASHER, WAVE 1/2ID X3/4D X.125		
24	86090270	87204	4	WASHER, RECTANGULAR HOLE		
25	86259400	87205	5	WASHER, THRUST.51 ID X 1 ODBRO		
26	86259410	87206	11	WASHER, THRUST.51 ID X1ODX.063		
27	86072340	14358	1	BRKT, TOWER		
28	86275180	70375	3	SCR, 5/16-18 X 1/2 HHCS GR5		

SOLUTION TANK GROUP- NON-TRACTION

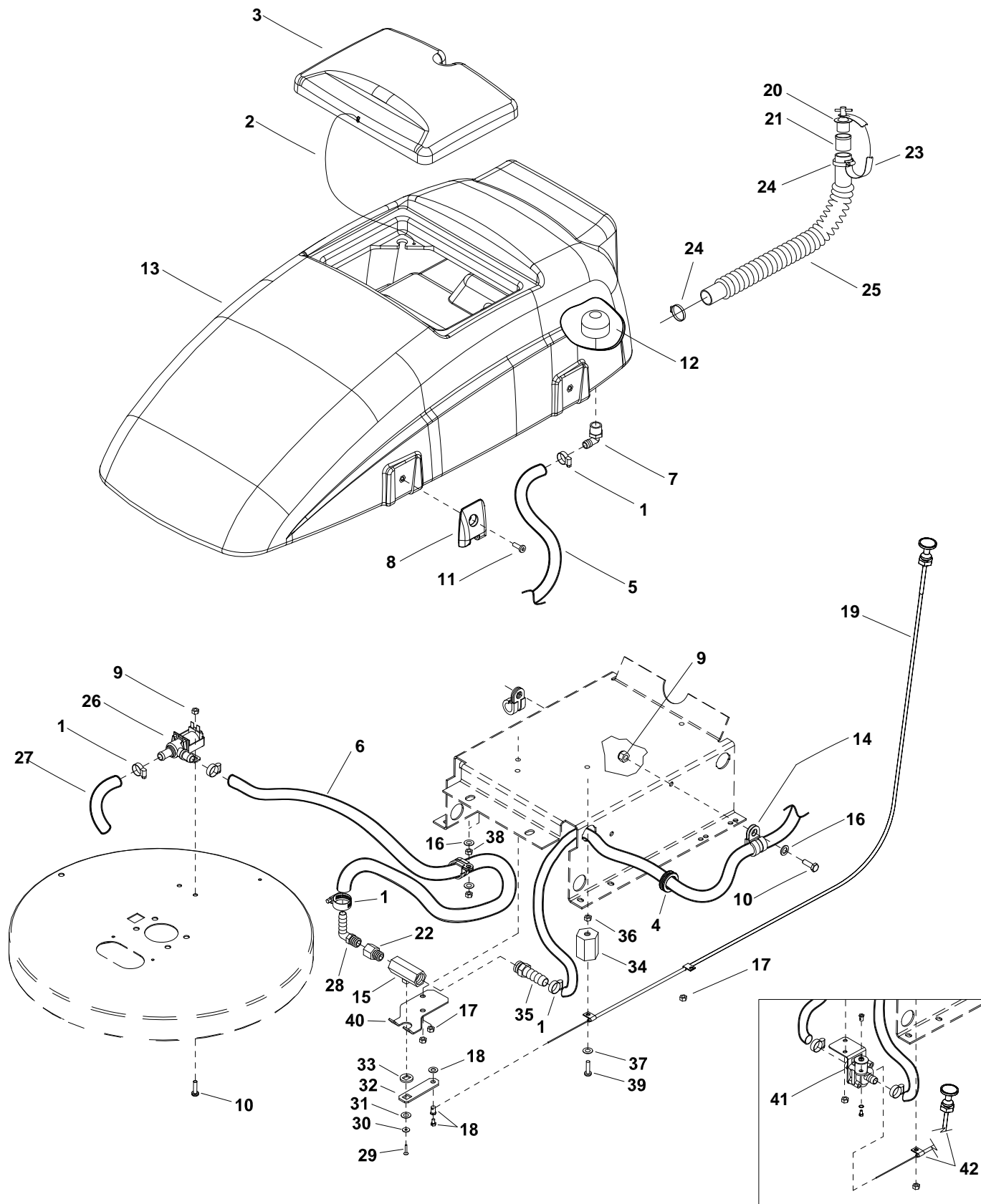

SOLUTION TANK GROUP – NON-TRACTION

REF	PART NO.	PRV NO.	QTY	DESCRIPTION	SERIAL NO. FROM	NOTES:
1	86233150	20042	5	CLAMP, 3/8 HOSE (D-SLOT)		
2	86279880	27425	1	CORD, SOLUTION COVER		
3	86234780	27772	1	COVER, SOLUTION TANK		
4	86238430	36191	2	GROMMET 1.00 ID 3/16 GRIP		
5	86282040	39558	1	HOSE, 1/2 ID NYLOBRAID X 40"		
6	86050350	39482	1	HOSE, 1/2 ID NYLOBRAID X 15"	*(4)	
7	86197940	40027	1	HOSEBARB, 3/8MPTX1/2 90D DL		
8	86004460	41333	2	HINGE, SCRUBBER TANK		
9	86005750	57113	2	NUT, 5/16-18 HEX NYLOCK		
10	86006760	70305	4	SCR, 5/16-18 X 3/4HHCSGR5PLTDL		
11	86007000	70632	2	SCR, 5/16-18 X 3/4 FHSCS BLKZC		
12	86007970	73864	1	STRAINER, 3/8 IN. NPT 60 MESH		
13	86008250	75293	1	TANK, SOLUTION		
14	86233410	81270	2	CLAMP, 3/4 DIA CUSHION .406DIA		
15	86258720	84075*	1	VALVE, 3/8 FPT BALL	*(3)	
16	86010670	87029	3	WASHER, 5/16 FLAT SS		
17	86005680	57047	4	NUT, 1/4-20 HEX NYLOCK		
18	86257310	73886*	1	SWIVEL, SOLUTION CABLE		
19	86002800	270121	1	CABLE, .062 X 43 SS PUSH/PULL		
20	86009700	82267	1	PLUG, 5/8" DRAIN HOSE		
21	86001600	40076	1	SLEEVE .63 ID X 1.0 OD		
22	86197310	141045	1	BUSHING, 3/8 X 3/8 NPT (F18-3)		
23	86008400	78499	1	TETHER, DRAIN PLUG		
24	86002390	20063	2	CLAMP, 1.75" WORM GEAR X .312		
25	86004310	39505	1	HOSE, 1.0 X 18.0 DRAIN		
26	86010540	84141	1	VALVE, 24VDC SOL. 1/2" HOSEBARB	*(4)	
27	86281990	39552	1	HOSE, 1/2 ID NYLOBRD X 4"	*(4)	
28	86197940	40027	1	HOSEBARB, 3/8 MPT X 1/2 90D DL	*(3)	
29	86275370	70447	1	SCR, 10-24 X 1/2 FHTC	*(3)	
30	86279470	87165	1	WASHER, #10 SPLIT LOCK PLTD	*(3)	
31	86010650	87018	1	WASHER, #10 X 9/16 OD	*(3)	
32	86077300	51406	1	LEVER, VALVE	*(3)	
33	86087350	730342	1	SPACER, VALVE	*(3)	
34	86255910	73659	1	STANDOFF, 1/4-20 X 1.0 HEX INS		
35	86001590	40049	1	HOSEBARB, 3/8 MPT X 1/2 NYLON	*(3)	
36	86270930	57065	1	NUT, 1/4-20 JAM SS		
37	86010660	87025	1	WASHER, 1/4 LOCK EXT STAR SS		
38	86005750	57113	2	NUT, 5/16-18 HEX NYLOCK		
39	86274920	70327	1	SCR, 1/4-20 X 3/8 PTHMS PL		
40	86075270	20108	1	CLAMP, VALVE		
41	86025960	47472	1	VALVE, SOLUTION		WAS 84167
42	86003190	27890	1	CABLE, .062 X 41 SS PUSH/PULL		
-	86026950	84202	-	VALVE ASM, 3/8 FPT BALL		▲

▲ INCLUDES ITEMS: 86068510-PRV NO. 40027, 86275370-PRV NO.70447, 86279470-PRV NO. 87165, 86010650-PRV NO. 87018, 86077300-PRV NO. 51406, 86087350-PRV NO. 730342, 86001590-PRV NO. 40049, 86197310-PRV NO. 141045, 86258720-PRV NO. 84075, 86257310-PRV NO. 73886

* SEE SERIAL NUMBER PAGE

SOLUTION GROUP - TRACTION

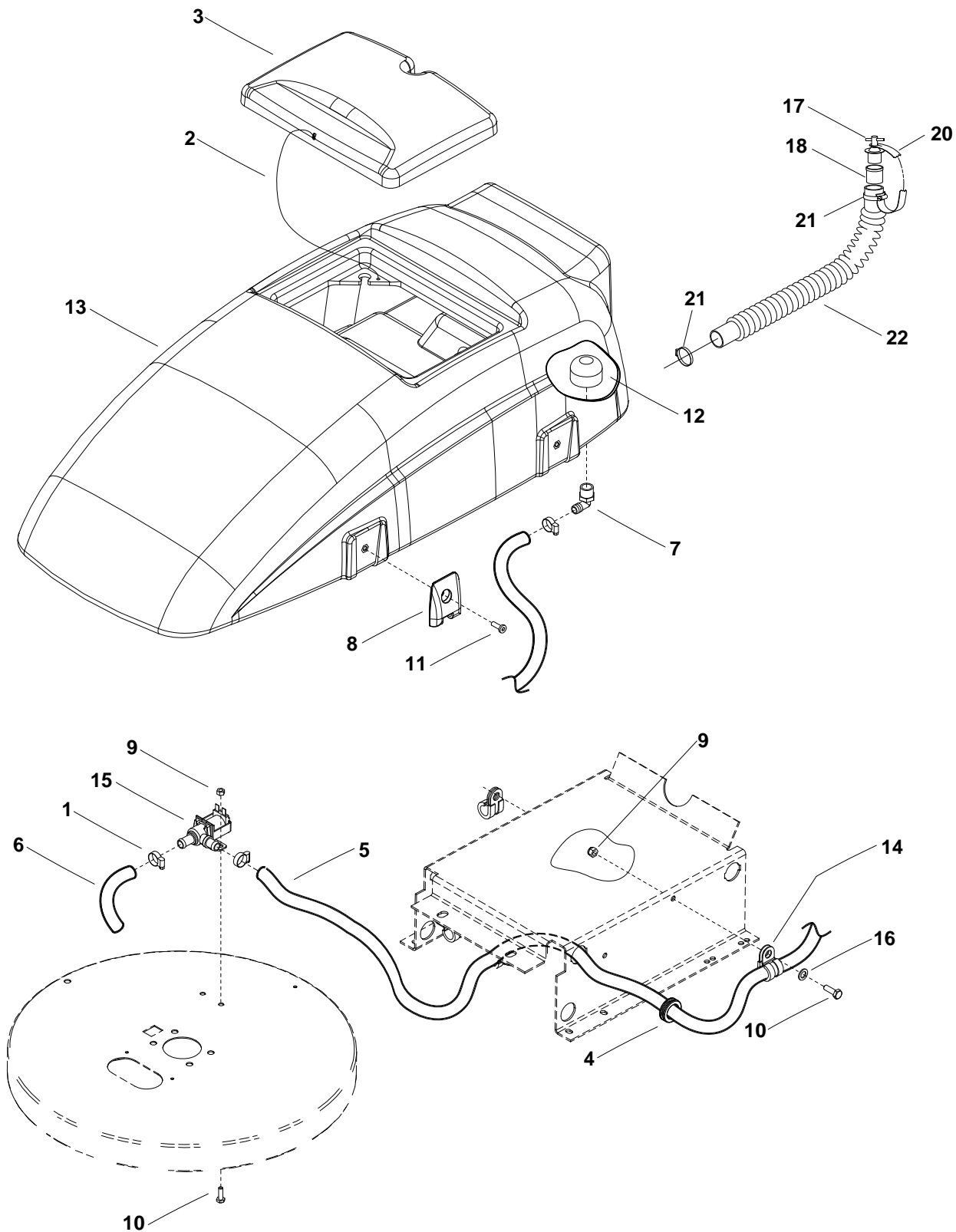

SOLUTION GROUP - TRACTION

REF	PART NO.	PRV NO.	QTY	DESCRIPTION	SERIAL NO. FROM	NOTES:
1	86233150	20042	3	CLAMP, 3/8 HOSE (D-SLOT)		
2	86279880	27425	1	CORD, SOLUTION COVER		
3	86234780	27772	1	COVER, SOLUTION TANK		
4	86238430	36191	2	GROMMET 1.00 ID 3/16 GRIP		
5	86281920	39538	1	HOSE, 1/2 ID NYLOBRAID X 52"		
6	86281990	39552	1	HOSE, 1/2 ID NYLOBRAID X 4"		
7	86197940	40027	1	HOSEBARB, 3/8MPTX1/2 90D DL		
8	86004460	41333	2	HINGE, SCRUBBER TANK		
9	86005750	57113	4	NUT, 5/16-18 HEX NYLOCK		
10	86006760	70305	4	SCR, 5/16-18 X 3/4HHCSGR5PLTDL		
11	86007000	70632	2	SCR, 5/16-18 X 3/4 FHSCS BLKZC		
12	86007970	73864	1	STRAINER, 3/8 IN. NPT 60 MESH		
13	86008250	75293	1	TANK, SOLUTION		
14	86233410	81270	1	CLAMP, 3/4 DIA CUSHION .406DIA		
15	86010540	84141	1	VALVE, 24VDC SOL. 1/2"HOSEBARB		
16	86010670	87029	2	WASHER, 5/16 FLAT SS		
17	86009700	82267	1	PLUG, 5/8" DRAIN HOSE		
18	86001600	40076	1	SLEEVE .63 ID X 1.0 OD		
19	-	OPEN	-	-		
20	86008400	78499	1	TETHER, DRAIN PLUG		
21	86002390	20063	2	CLAMP, 1.75" WORM GEAR X .312		
22	86004310	39505	1	HOSE, 1.0 X 18.0 DRAIN		

SQUEEGEE GROUP

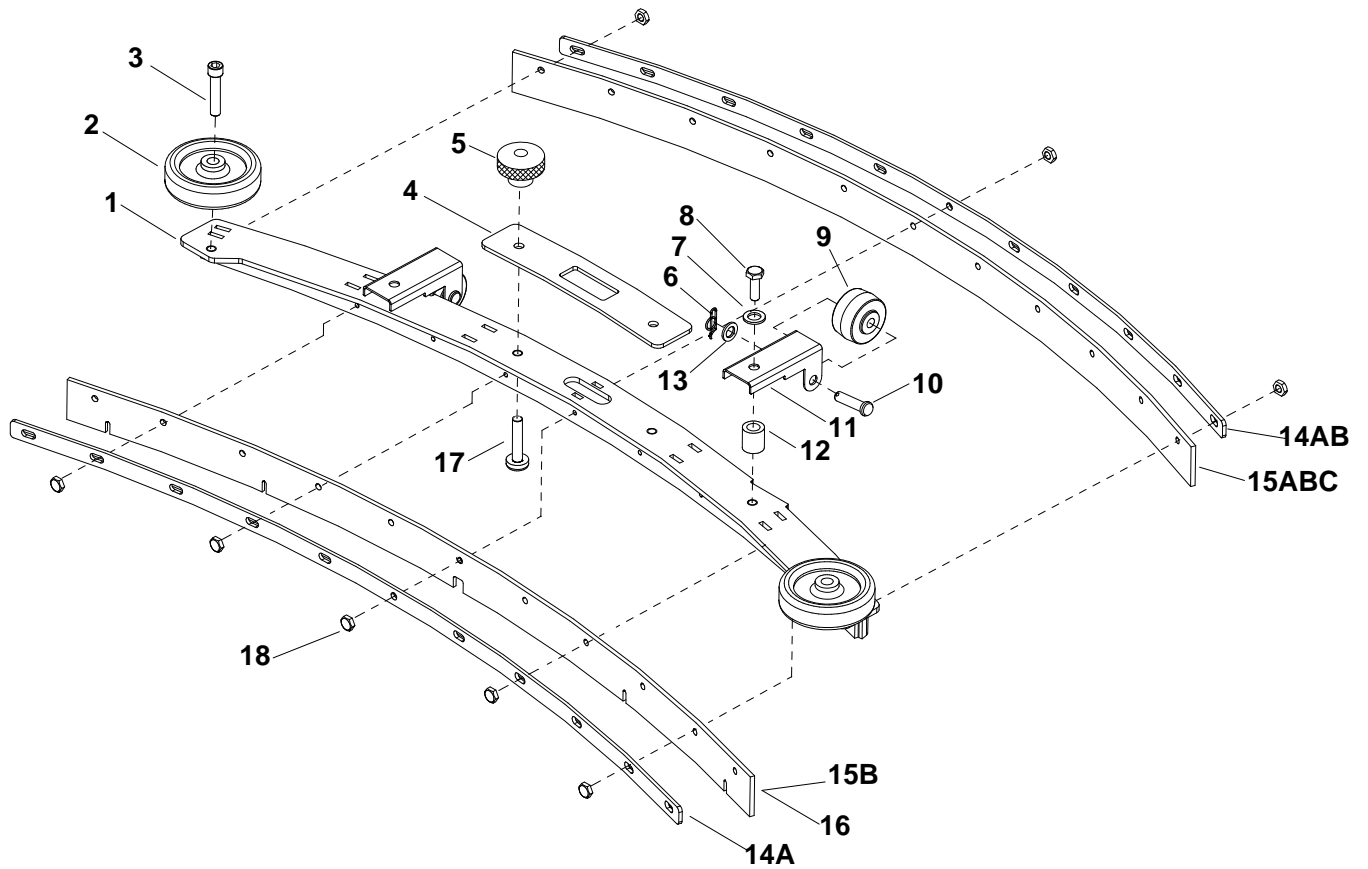

SQUEEGEE GROUP

REF	PART NO.	PRV NO.	QTY	DESCRIPTION	SERIAL NO. FROM	NOTES:
1	86096000	89215	1	WELDMENT, SQUEEGEE MAIN		
2	86010890	89059	2	WHEEL, BUMPER		
3	86278350	70729	2	SHOULDER BOLT, 3/8 OD X 1.0 L SS		
4	86003980	35249	1	GASKET, SQG .13 THK X 8.00 LG		
5	86219690	48080	2	KNOB, 1.50 OD X 5/16-18		
6	86008660	80605	2	COTTER, 5/16" RING		
7	86010670	87029	2	WASHER, 5/16 FLAT SS		
8	86276780	70728	2	SCR, 5/16-18 X 3/4HHCS SS		
9	86010880	89058	2	WHEEL,1.5OD X .31ID X.75W GRY		
10	86006200	66161	2	PIN, CLEVIS 5/16" X 1.50" PLTD		
11	86001810	14390	2	BRKT, SQG WHEEL		
12	86008320	78356	2	SPACER, .314 X .59 X .36 NYLON		
13	86279650	87222	2	WASHER, SEAL 5/16 X 3/4 OD		
14A	86087870	730002	2	STRAP, FRONT AND REAR STANDARD		
14B	86088090	730226	-	STRAP, REAR CLOSED END HIGH VAC		OPTIONAL
15A	86007370	730058	1	BLADE, RED REAR SOFT DURO 40		
15B	86007260	730003	-	BLADE, BLU RIB FRT/REAR URETHAN		OPTIONAL
15C	86007610	730227	-	BLADE, RED REAR MEDIUM DURO 60		OPTIONAL
16	86007360	730057	1	BLADE, RED FRONT 5 SLOT DURO 40		
17	86276650	70707	2	SCR, 5/16-18 X 1.5 BSHCS SS		
18	86271770	57252	8	NUT, 10-24 HEX NYLOCK SS		

SQUEEGEE LIFT GROUP

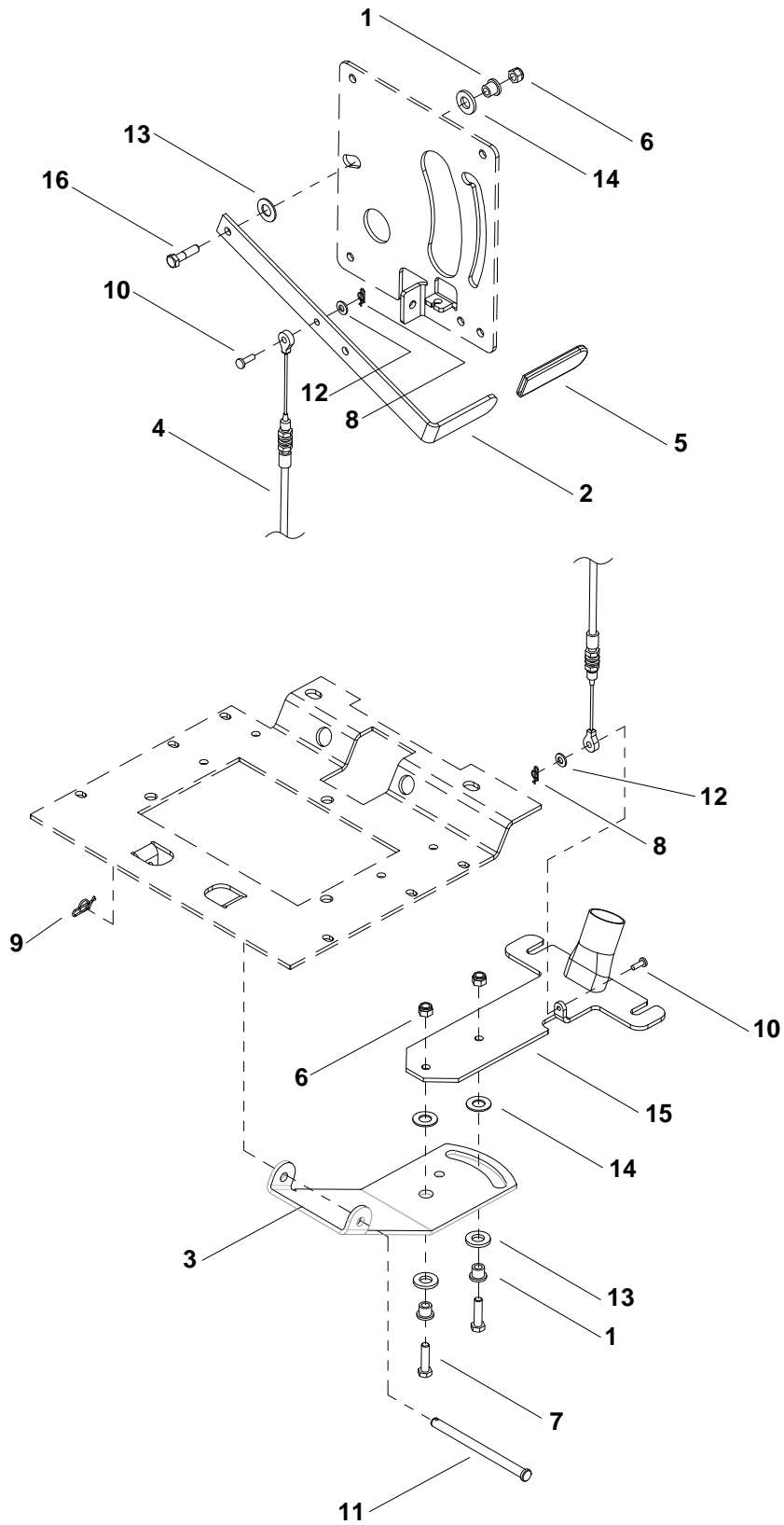

SQUEEGEE LIFT GROUP

REF	PART NO.	PRV NO.	QTY	DESCRIPTION	SERIAL NO. FROM	NOTES:
1	86228840	09124	4	BEARING, FLANGED.314IDX.502OD		
2	86077220	14359	1	LEVER, SQUEEGEE LIFT		
3	86072410	14367	1	BRKT, SQG PIVOT, LIFT		
4	86003180	27870	1	CABLE, .09X29, 0707,SS,LB,E-E		
5	86238330	36201	1	GRIP, .187 X 1.0 X 3.5		
6	86005750	57113	4	NUT, 5/16-18 HEX NYLOCK		
7	86274910	70325	2	SCR, 5/16-18 X 1.25HHCS GR5PLT		
8	86008650	80604	2	COTTER, 1/4 RING		
9	86008670	80606	1	COTTER, 3/8 RING		
10	86009560	82053	2	PIN, CLEVIS 1/4'X5/8" PLTD		
11	86272710	82060	1	PIN, CLEVIS 3/8 X 5.25 PLTD		
12	86010630	87013	2	WASHER, 1/4 ID X 5/8 OD SS		
13	86259400	87205	4	WASHER, THRUST.51 ID X 1 ODBRO		
14	86259410	87206	4	WASHER, THRUST.51 ID X1ODX.063		
15	86095990	89214	1	WELDMENT, SQUEEGEE LINK		
16	86276760	70724	2	SCR, 5/16-18 X 1.25 BSHCS		

DELUXE SQUEEGEE GROUP

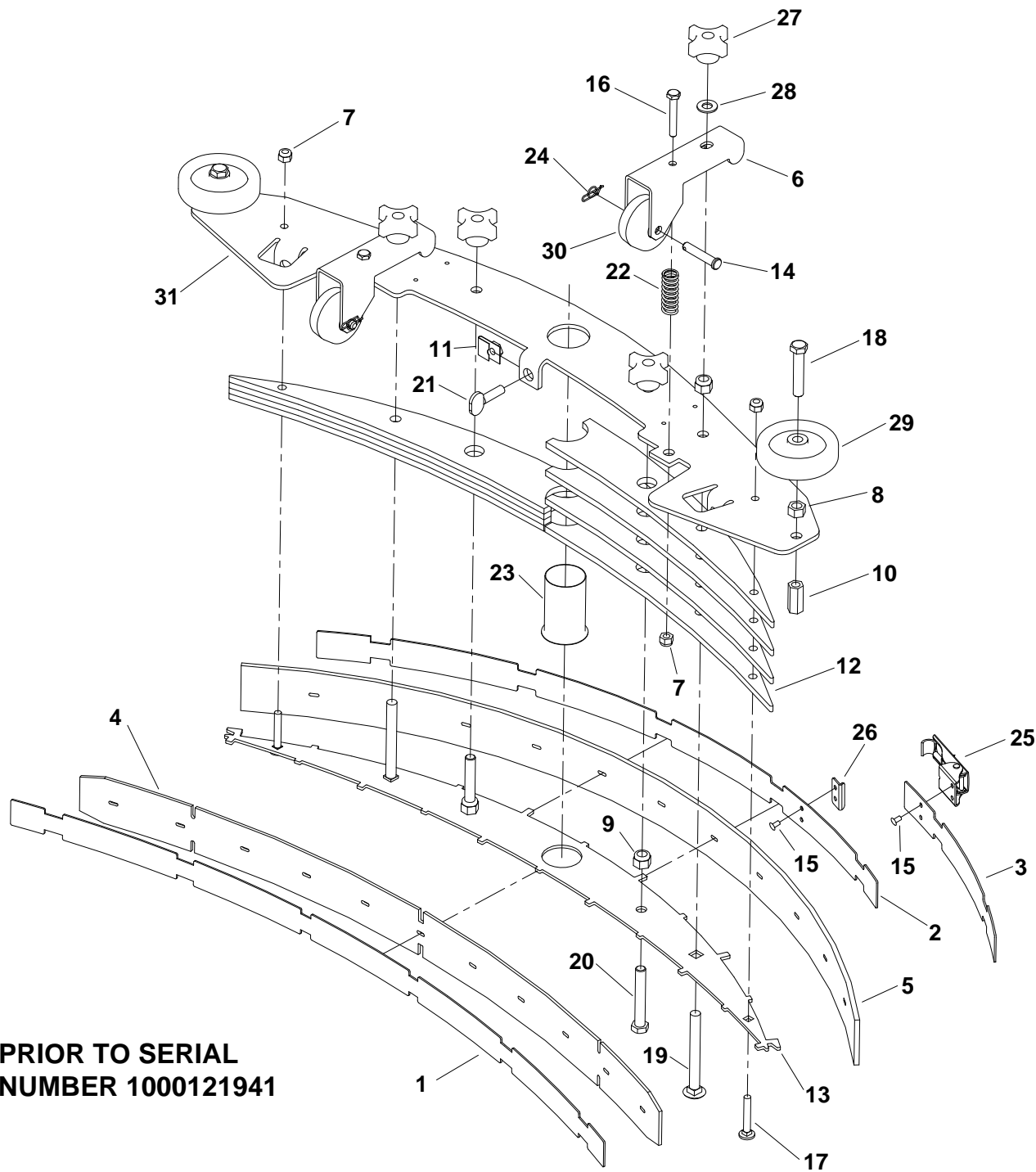

**PRIOR TO SERIAL
NUMBER 1000121941**

DELUXE SQUEEGEE GROUP

REF	PART NO.	PRV NO.	QTY	DESCRIPTION	SERIAL NO. FROM	NOTES:
1	86001840	14412	1	BAND, SQUEEFEE FRONT		
2	86001850	14413	1	BAND, SQUEEGEE REAR		
3	86001860	14414	1	BAND, SQUEEGEE REAR		
4	86001870	14415	1	BLADE, SQUEEGEE FRONT		
5	86001880	14416	1	BLADE, SQUEEGEE REAR		
6	86069370	140385	2	BRKT, WHEEL MOUNT		
7	86005680	57047	4	NUT, 1/4-20 HEX NYLOCK		
8	86005730	57111	2	NUT, 3/8-16 HEX		
9	86005770	57119	4	NUT, 3/8-16 HEX NYLOCK		
10	86005840	57269	2	NUT, 3/8-16 HEX COUPLING SS		
11	86271820	57270	3	NUT, 5/16-18 CAPTIVE "J" PLTD		
12	86249510	62869	8	PLATE, SQUEEGEE FILLER		
13	86249520	62870	1	PLATE, SQG BLADE RETAINER		
14	86006270	66276	2	PIN, CLEVIS 5/16 X 1.625 LG		
15	86006400	67380	4	RIVET, 5/32 OF X 1/8 GRIP		
16	86231570	70105	2	SCR, 1/4-20 X 1.75 HHCS PLTD		
17	86274790	70291	2	SCR, 1/4-20 X 1.5 ELEVATOR		
18	86006820	70385	2	SCR, 3/8-16 X 2.0 HHCS GR5 PLT		
19	86276530	70678	2	SCR, 3/8-16X3.5 CARRIAGE PLTD		
20	86276540	70679	2	SCR, 3/8-16 X 2.5 HHTB GR5 PLT		
21	86007040	70680	3	SCR, 5/16-18X1 THUMB SS TYPE P		
22	86007780	73576	2	SPRING, COMP .60D X2.0L X.045W		
23	86088860	78034	1	TUBE, 1.5 OD X 2.5 VAC INTAKE		
24	86008660	80605	2	COTTER, 5/16" RING		
25	86009170	81488	1	LATCH, SQUEEGEE STRAP		
26	86009180	81489	1	STRIKER, SQUEEGEE STRAP REAR		
27	86009200	81535	4	KNOB, 3/8-16 4 PRONG		
28	86010680	87030	2	WASHER, 3/8 ID X 3/4 OD NYLON		
29	86010890	89059	2	WHEEL, BUMPER		
30	86011000	89197	2	WHEEL, 2 OD X.31IDX.875W, GRY		
31	86081970	62868	1	PLATE, SQG RETAINER TOP		

DELUXE SQUEEGEE GROUP

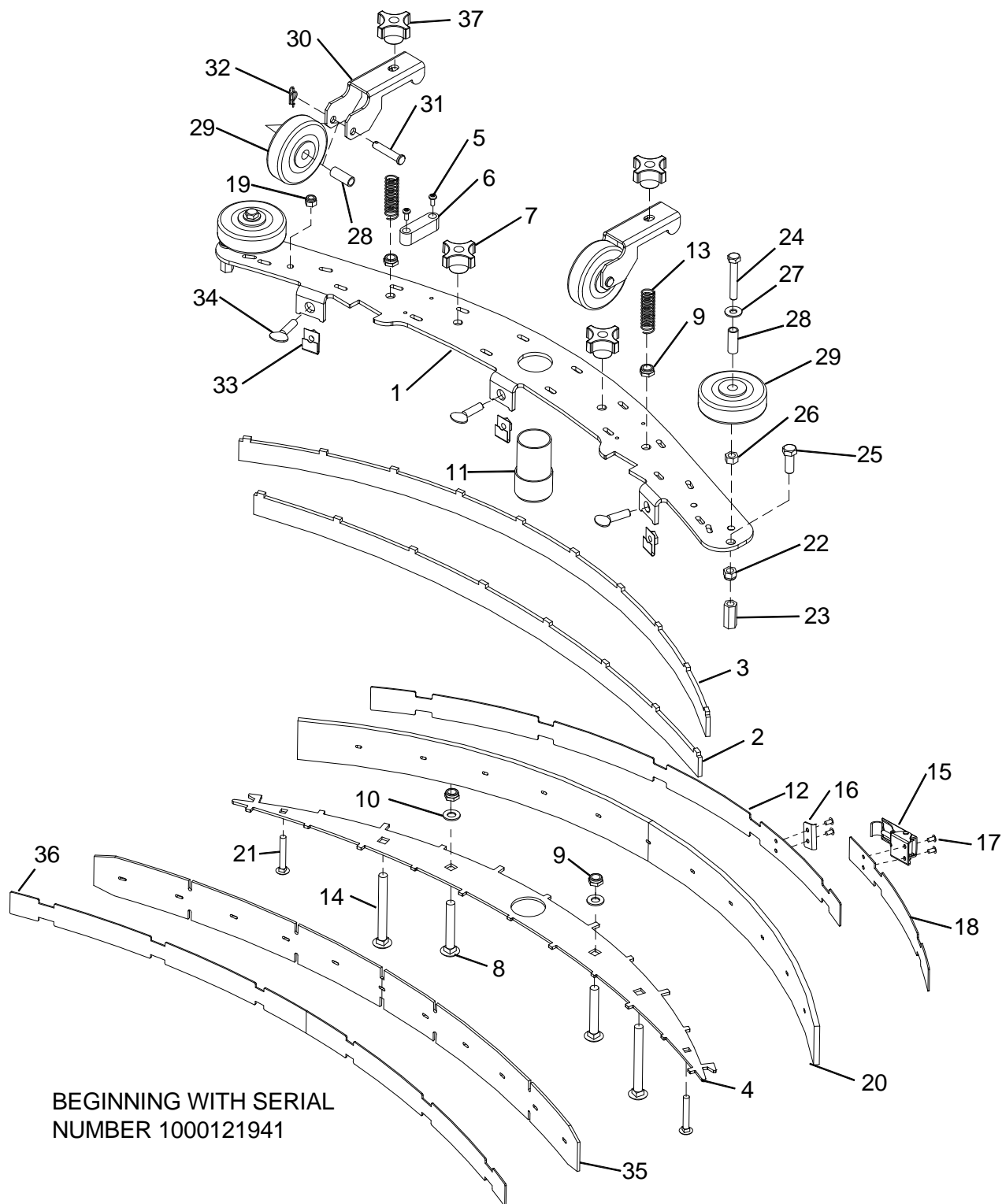

BEGINNING WITH SERIAL
NUMBER 1000121941

DELUXE SQUEEGEE GROUP

REF	PART NO.	PRV NO.	QTY	DESCRIPTION	SERIAL NO. FROM	NOTES:
1	86082500	62979	1	PLATE, SQUEEGEE TOP 32 IN		
2	86082510	62980	1	PLATE, SQG VERTICAL FILLER (F)		
3	86082520	62981	1	PLATE, SQG VERTICAL FILLER (R)		
4	86082530	62982	1	PLATE, SQUEEGEE BOTTOM 32 IN		
5	86274130	70098	2	SCR, 8-32 X 3/8 PHTC 'F' PLTD		
6	86009910	82576	1	VIAL, LEVEL		
7	86009200	81535	2	KNOB, 3/8-16 4 PRONG ALUM		
8	86276870	70748	2	SCR, 3/8-16 X 2.50 CARRIAGE SS		
9	86005630	57022	4	NUT, 3/8-16 HEX NYLOCK THIN SS		
10	86010680	87030	2	WASHER, 3/8ID X 3/4OD NYLON		
11	86008390	78493	1	TUBE ASM, SQUEEGEE VAC		
12	86001850	14413	1	BAND, REAR SQUEEGEE		
13	86007780	73576	2	SPRING, COMP .60D X 2.0L X .045W		
14	86276990	70776	2	SCR, 3/8-16 X 3.5 CARRIAGE SS		
15	86009170	81488	1	LATCH, SQUEEGEE STRAP		
16	86009180	81489	1	STRIKER, SQUEEGEE STRAP REAR		
17	86006400	67380	4	RIVET, 5/32 OF X 1/8 GRIP		
18	86001860	14414	1	BAND, REAR SQUEEGEE		
19	86005810	57245	2	NUT, 1/4-20 HEX NYLOCK SS		
20	86001880	14416	1	BLADE, SQUEEGEE REAR LINATEX 3/16		
21	86277000	70777	2	SCR, 1/4-20 X 1.75 CARRIAGE SS		
22	86270830	57023	2	NUT, 5/16-18 HEX NYLOCK SS		
23	86005840	57269	2	NUT, 3/8-16 HEX COUPLING SS		
24	86276980	70775	2	SCR, 5/16-18 X 2 HHCS SS		
25	86276920	70755	2	SCR, 3/8-16 X 1 HHCS SS NP		
26	86005650	57031	2	NUT, 5/16-18 HEX		
27	86010670	87029	2	WASHER, 5/16 FLAT SS		
28	86001350	140390	4	BUSHING, SPANNER .435 X 1.10		
29	86011020	89202	4	WHEEL, 3" DIA CUSHION RUBBER		
30	86069870	140531	2	BRACKET, SQG WHEEL		
31	86006270	66276	2	PIN, CLEVIS 5/16 X 1.625 LG		
32	86008660	80605	2	COTTER, 5/16" RING		
33	86271820	57270	3	NUT, 5/16-18 CAPTIVE "J" PLTD		
34	86007040	70680	3	SCR, 5/16-18 X 1 THUMB SS TYPE P		
35	86001870	14415	1	BLADE, SQUEEGEE FRONT (3-SLOTS)		
36	86001840	14412	1	BAND, SQUEEGEE FRONT		
37	86004890	48095	2	KNOB, ALUM 3/8-16 NYLOCK NUT SS		

NOTE: COMPLETE SQUEEGEE ASSEMBLY IS AVAILABLE, PN 86026560, PRV NO. 47442

DELUXE SQUEEGEE LIFT GROUP

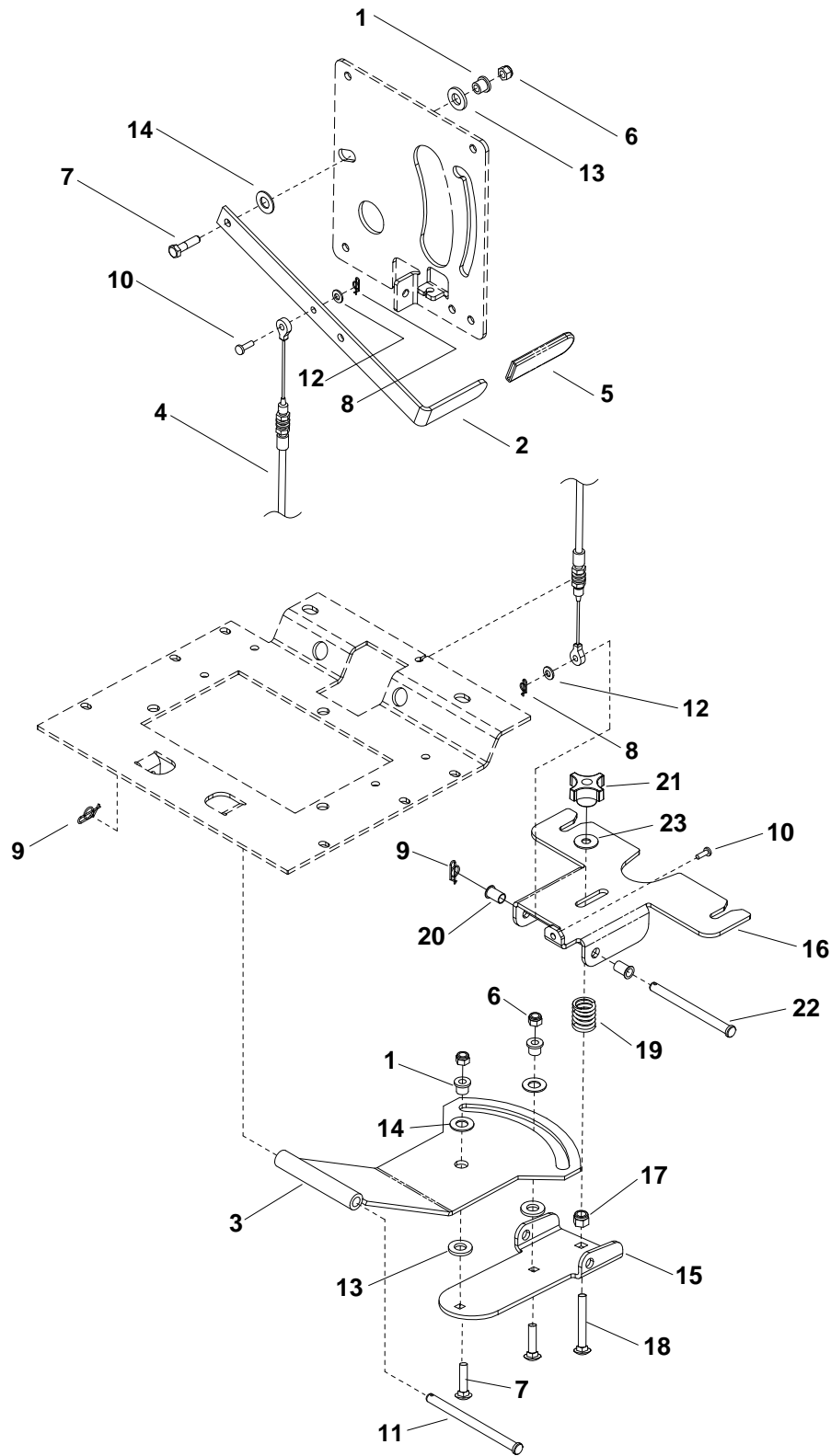

DELUXE SQUEEGEE LIFT GROUP

REF	PART NO.	PRV NO.	QTY	DESCRIPTION	SERIAL NO. FROM	NOTES:
1	86228840	09124	4	BEARING, FLANGED.314IDX.502OD		
2	86077220	14359	1	LEVER, SQUEEGEE LIFT		
3	86065100	14417	1	BRKT, SQG PIVOT/LIFT		
4	86003180	27870	1	CABLE, .09X29, 0707,SS,LB,E-E		
5	86238330	36201	1	GRIP, .187 X 1.0 X 3.5		
6	86271840	57285	4	NUT, 5/16-18 HEX NYLOCK THIN SS		
7	86277130	70795	4	SCR, 5/16-18 X 1.00 CARRIAGE SS		
8	86008650	80604	2	COTTER, 1/4 RING		
9	86008670	80606	1	COTTER, 3/8" RING		
10	86009560	82053	2	PIN, CLEVIS 1/4'X5/8" PLTD		
11	86272710	82060	1	PIN, CLEVIS 3/8 X 5.25 PLTD		
12	86010630	87013	2	WASHER, 1/4 ID X 5/8 OD SS		
13	86259400	87205	4	WASHER, THRUST.51 ID X 1 ODBRO		
14	86259410	87206	4	WASHER, THRUST.51 ID X1ODX.063		
15	86072530	14409	1	BRKT, CAMBER PIVOT		
16	86073710	14410	1	BRKT, SQUEEGEE MOUNT		
17	86005630	57022	1	NUT, 3/8-16 HEX NYLOCK THIN SS		
18	86276870	70748	1	SCR, 3/8-16 X 2.50 CARRIAGE SS		
19	86007310	730022	1	SPRING, COM .97 ODX1.5LX .135W		
20	86008870	80815	2	BEARING,FLANGED 3/8" ID 11/16"		
21	86009200	81535	1	KNOB, 3/8-16 4 PRONG		
22	86249060	82061	1	PIN, CLEVIS 3/8 X 4.63 PLTD		
23	86279510	87171	1	WASHER, 3/8 FLAT		

VACUUM GROUP

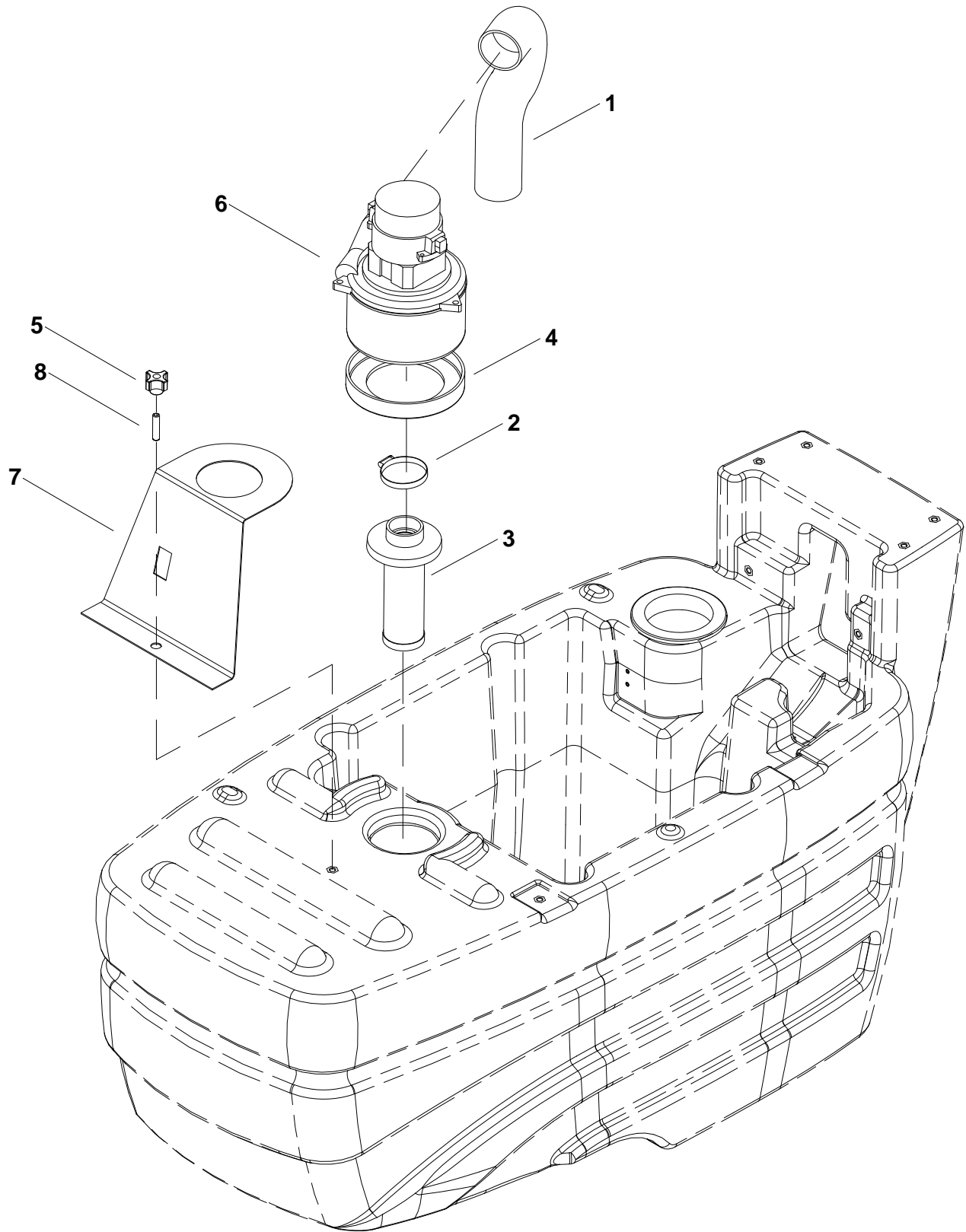

VACUUM GROUP

REF	PART NO.	PRV NO.	QTY	DESCRIPTION	SERIAL NO. FROM	NOTES:
1	86240210	39559	1	HOSE ASM, 1.5 BLK VAC X 6.0		
2	86002390	20063	1	CLAMP, 1.75" WORM GEAR X .312		
3	86236400	34366	1	FLOAT SHUT-OFF		
4	86237230	35087	1	GASKET, 5.7 VAC MOTOR		
5	86004790	48012	1	KNOB, 5/16-18 4 PRONG		
6	86005460	53801	1	VAC MOTOR ASM, 24VDC 3 STAGE		
-	86135370	14548	-	BRUSH SET, 24V 3ST VAC AMETEK		SERVICE ONLY
-	86135310	140686	-	BRUSH SET, 24V/36V VAC WINDSOR	*(5)	SERVICE ONLY
7	86081750	62827	1	PLATE, VAC RETAINER		
8	86278110	81491	1	SET SCR, 5/16-18 X1.5 CP SS DL		

* SEE SERIAL NUMBER PAGE

WHEELS AND FRAME GROUP - NON-TRACTION

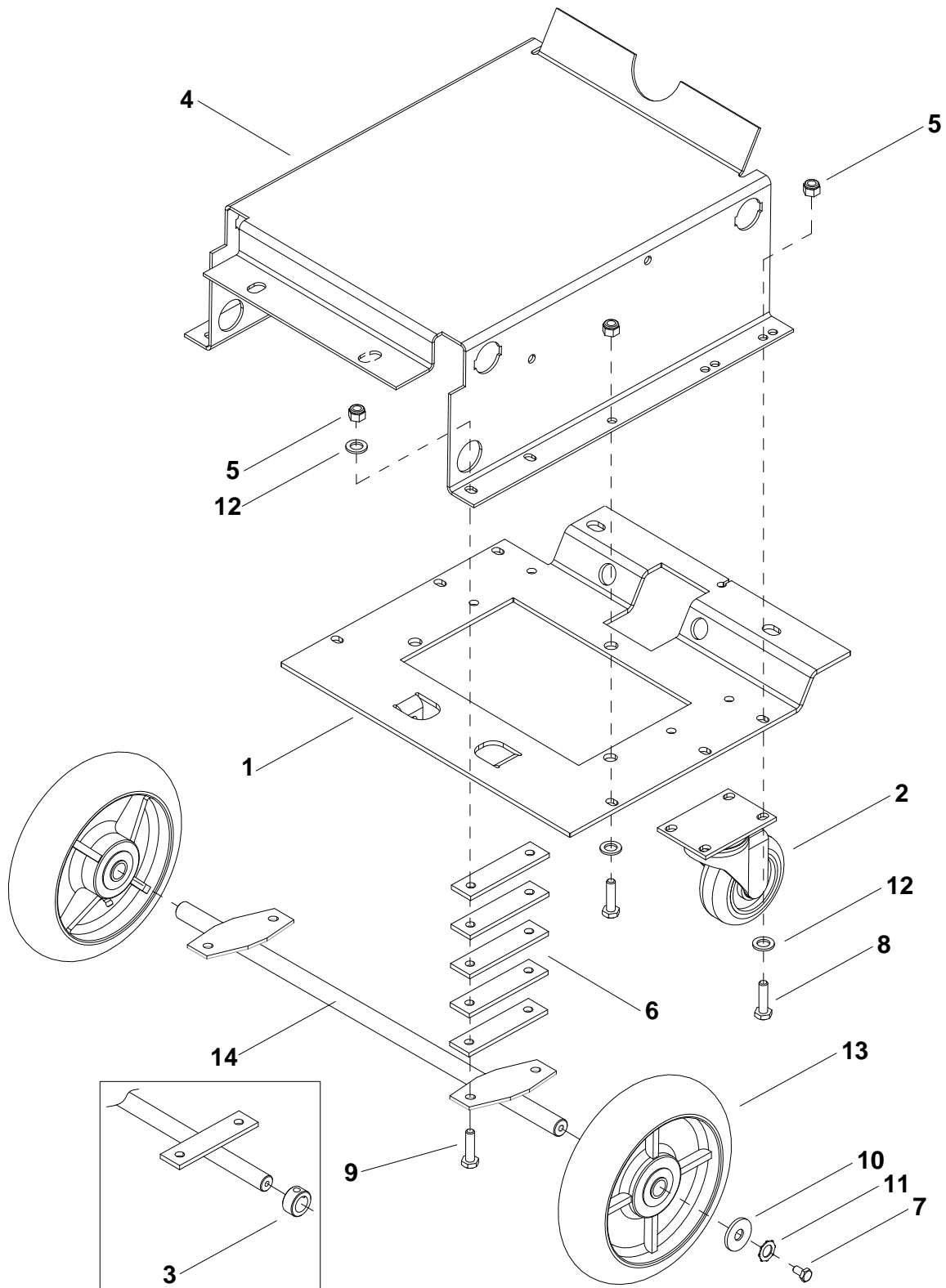

WHEELS AND FRAME GROUP - NON-TRACTION

REF	PART NO.	PRV NO.	QTY	DESCRIPTION	SERIAL NO. FROM	NOTES:
1	86072400	14366	1	BRKT, FRAME BOTTOM		
2	86002300	18039	2	CASTER, SWIVEL 3.50 X 4.69		
3	86233600	27122	2	COLLAR, 1.0X.625X.50 TAP'D STL		SERVICE ONLY
4	86075780	34368	1	FRAME, MAIN		
5	86270830	57023	14	NUT, 5/16-18 HEX NYLCK		
6	86081870	62844	10	PLATE, TRANSAXLE SPACER		
7	86273830	70020	2	SCR, 1/4-20 X 1/2 HHCS SS DL		
8	86006560	70083	10	SCR, 5/16-18 X 1"HHCSGR5PLT DL		
9	86274690	70258	4	SCR, 5/16-18 X 1.5 HHCS GR5 PLTD		
10	86278940	87008	2	WASHER, 1/4 ID X 1-1/4 OD PLT		
11	86010660	87025	2	WASHER, 1/4 LOCK EXT STAR SS		
12	86010670	87029	14	WASHER, 5/16 FLAT SS		
13	86011100	89257	2	WHEEL, 8" X 2" X .63 ID PERFORMA	*(6)	WAS 89181
14	86066290	05219	1	WELDMENT, AXLE	*(6)	WAS 89217
15	86230250	09136	-	BEARING, REPLACEMENT FOR 89181		(NOT SHOWN)

* SEE SERIAL NUMBER PAGE

WHEELS AND FRAME GROUP - TRACTION

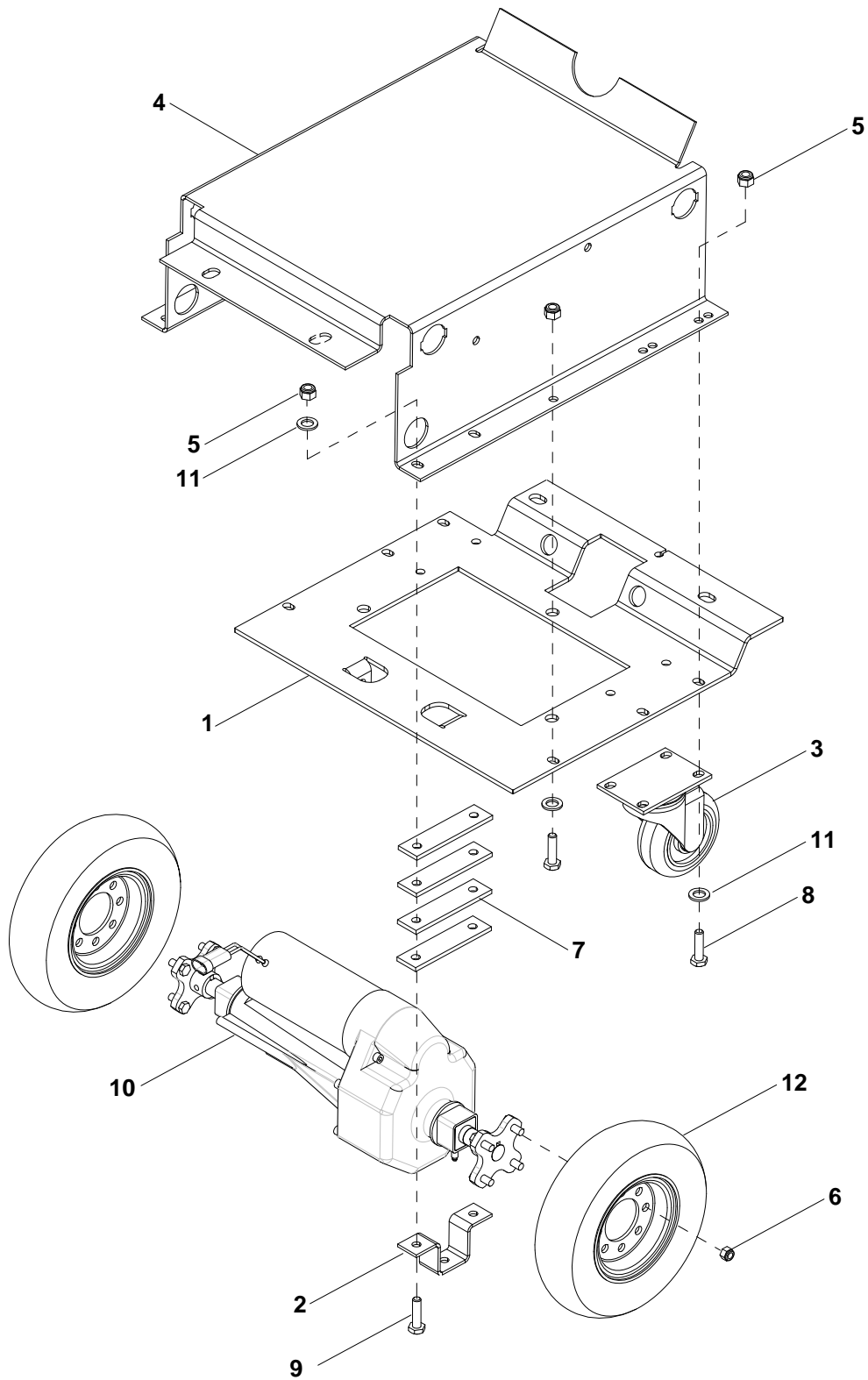

WHEELS AND FRAME GROUP - TRACTION

REF	PART NO.	PRV NO.	QTY	DESCRIPTION	SERIAL NO. FROM	NOTES:
1	86072400	14366	1	BRKT, FRAME BOTTOM		
2	86230330	14369	2	BRKT, TRANSAXLE MOUNT		
3	86002300	18039	2	CASTER, SWIVEL 3.50 X 4.69		
4	80675780	34368	1	FRAME, MAIN	*(7)	
5	86270830	57023	14	NUT, 5/16-18 HEX NYLCK		
6	86005780	57128	8	NUT, 5/16-24 HEX NYLOCK PLTD		
7	86081870	62844	8	PLATE, TRANSAXLE SPACER		
8	86006560	70083	10	SCR, 5/16-18 X 1"HHCSGR5PLT DL	*(7)	
9	86274910	70325	4	SCR, 5/16-18 X 1.25 HHCS GR5		
10	86008380	78440	1	TRANSAXLE, 24VDC		
-	86216150	140588	-	BRUSH SET, 24V TRANSAXLE		NOT SHOWN
-	86135880	47372	-	HUB KIT, 78440 TRANSAXLE		SERVICE ONLY
-	86241840	48091	-	KEY, WOODRUFF .75ID HUB		SERVICE ONLY
11	86010670	87029	14	WASHER, 5/16 FLAT SS		
12	86011080	89222	2	WHEEL, 7.87 X 2 X 1.77 BLK	*(8)	

* SEE SERIAL NUMBER PAGE

ONBOARD CHARGER

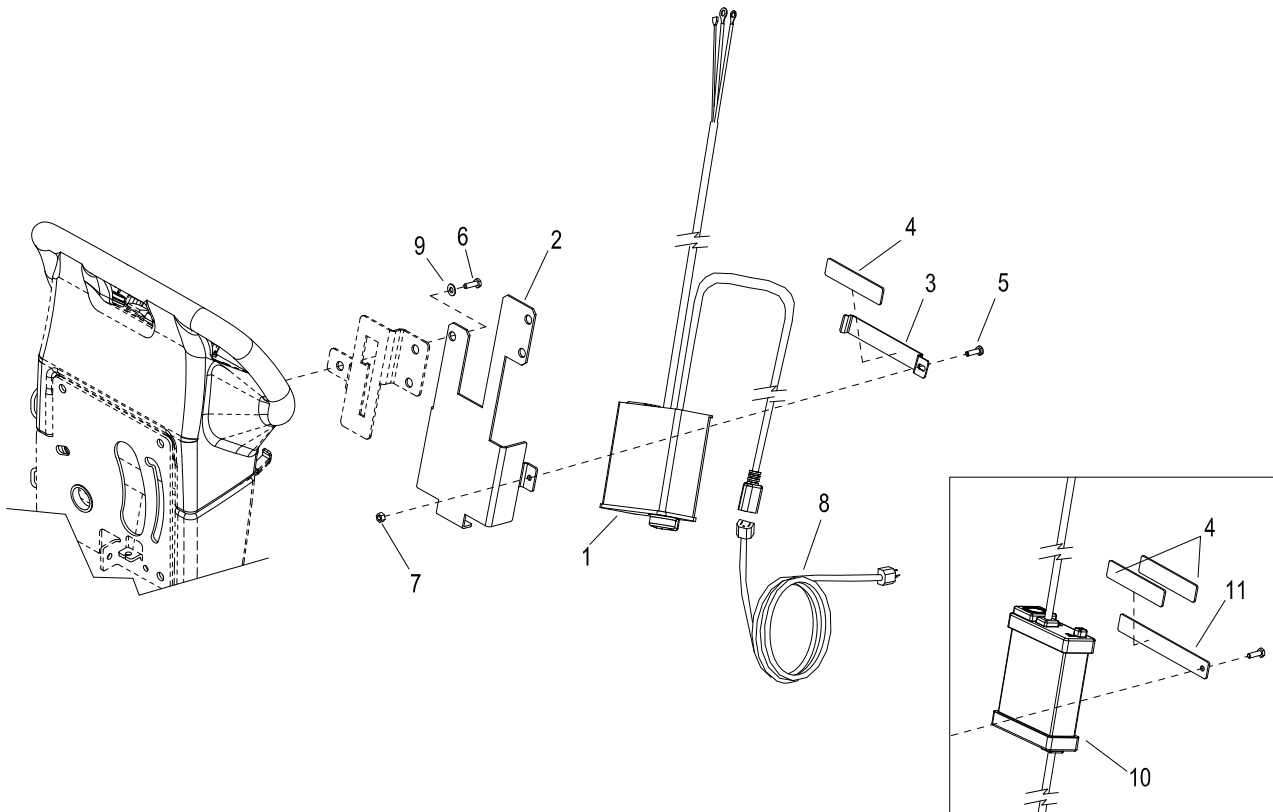

ONBOARD CHARGER

REF	PART NO.	PRV NO.	QTY	DESCRIPTION	SERIAL NO. FROM	NOTES:
1	86329590	-	1	CHRGR, 24V 9A, 20" LEAD ACID	*(9)	
2	86065090	140919	1	BRKT, CHARGER 20 INCH		
3	86329650	-	1	LOCK PLATE, 20" SPE CHARGER	*(9)	
4	86198530	99809	0.8	FOAM TAPE, 1/8T X 3/4 1SDA		
5	86275210	70384	1	SCR, 1/4-20 X 1/2 PHTR BLK DL		
6	86006760	70305	3	SCR, 5/16-18 X 3/4 HHCS GR5 PLTDL		
7	86005710	57105	1	NUT, 1/4-20 HEX W/STAR WASHER		
8	86234390	23725	1	CORD ASM, 16/3 SJTW X 2M IEC		
9	86010670	87029	3	WASHER, 5/16 FLAT SS		
10	86232960	270137	1	CHARGER, CURTIS 1608FS SC20		
11	86079380	620109	1	PLATE, CHARGER 20 INCH		

* SEE SERIAL NUMBER PAGE

WIRING GROUP – BATTERY CABLES

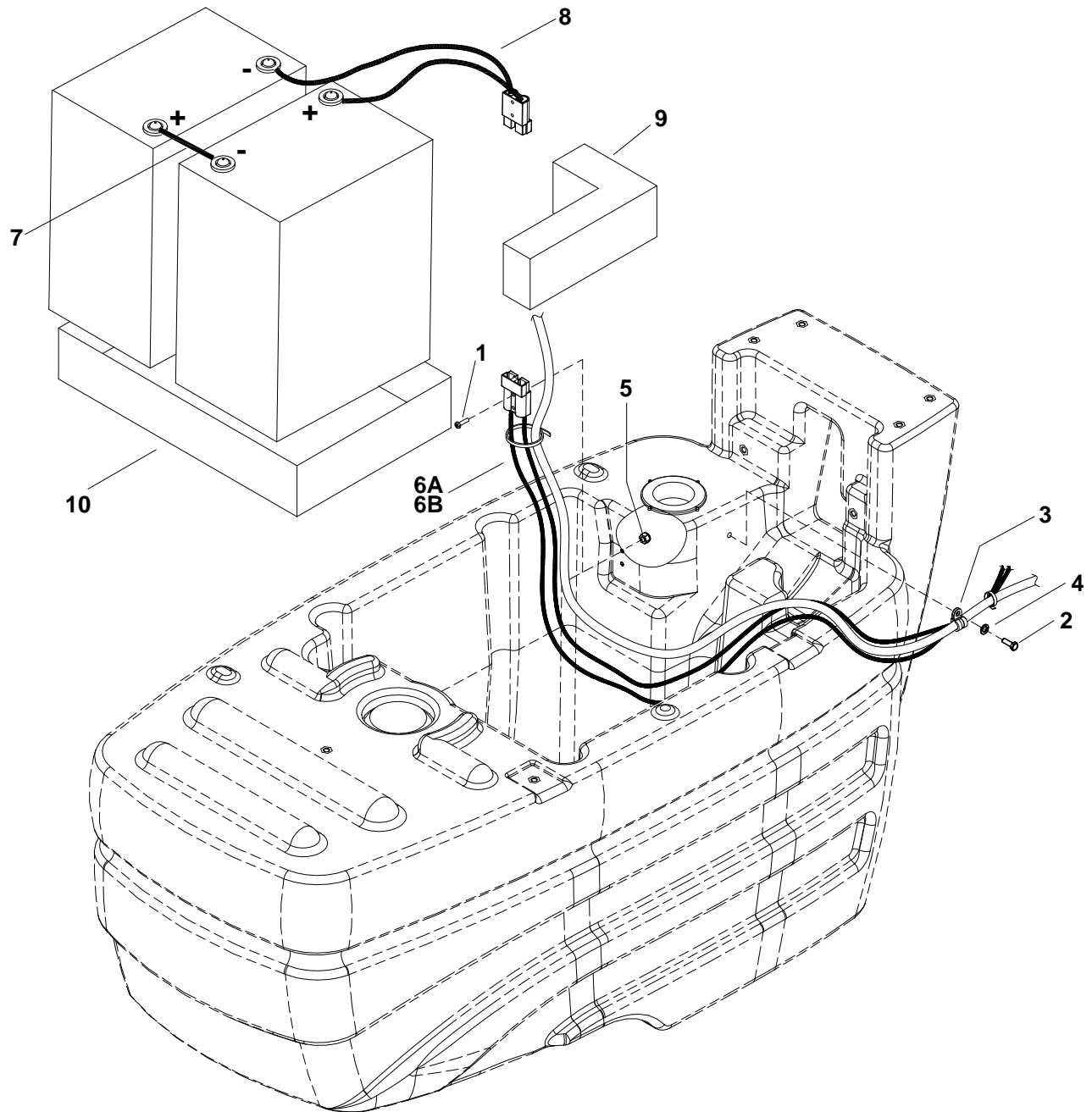

WIRING GROUP - BATTERY CABLES

REF	PART NO.	PRV NO.	QTY	DESCRIPTION	SERIAL NO. FROM	NOTES:
1	86275550	70500	2	SCR, 6-32 X 1.25 PPHMS		
2	86006760	70305	1	SCR, 5/16-18 X 3/4HHCSGR5PLTDL		
3	86233410	81270	1	CLAMP, 3/4 DIA CUSHION .406DIA		
4	86010670	87029	1	WASHER, 5/16 FLAT SS		
5	86270920	57049	2	NUT, 6-32 HEX NYLOCK SS		
6A	86260460	880261	1	WIRE ASM, 33, 6G 1/4 RING		NON-TRACTION
6B	86260470	880268	1	WIRE ASM, 26.5, 6G RING		TRACTION
7	86002510	23125	1	WIRE 4X15 BCLAMPXBCLAMP		
8	86002540	23174	1	WIRE ASM 2X21 BATT W/ANDERSON		
9	86264980	14406	2	BLOCK, 10.0 X 7.0 X 3.0		
10	86064650	78452	1	TRAY, BATTERY		OPTIONAL

WIRING GROUP – CONTROL PANEL - NON-TRACTION

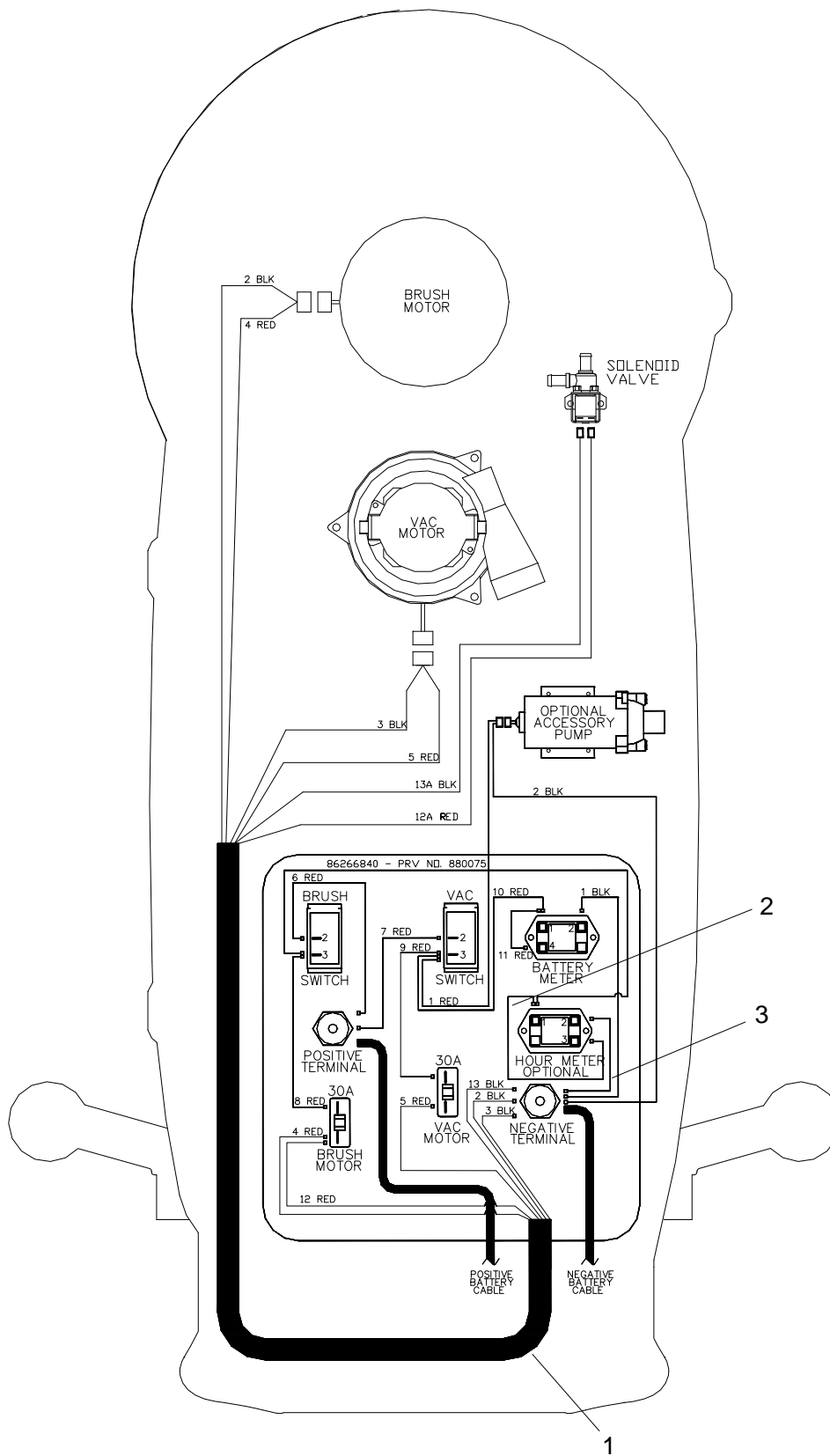

WIRING GROUP – CONTROL PANEL – NON-TRACTION

REF	PART NO.	PRV NO.	QTY	DESCRIPTION	SERIAL NO. FROM	NOTES:
1	86238880	41367	1	HARNES, MAIN		
2	86268650	88490	1	WIRE, 4" RED/18 76040 X 76040		
3	86266690	880034	1	WIRE, 6" BLK/18 76011 X 76040		

**WIRING GROUP – CONTROL PANEL – NON-TRACTION
WITH BATTERY CHARGER**

REF	PART NO.	PRV NO.	QTY	DESCRIPTION	SERIAL NO. FROM	NOTES:
1	86238880	41367	1	HARNES, MAIN		
2	86268650	88490	1	WIRE, 4" RED/18 76040 X 76040		
3	86266690	880034	1	WIRE, 6" BLK/18 76011 X 76040		
4	86268030	880456	1	WIRE, 14" RED/10 76081 X 76064		
5	86268040	880458	1	WIRE, 14" RED/14 76001 X 76029		
6	86268050	880459	1	WIRE, 14" RED/12 76064 X 76064		
7	86268070	880463	1	WIRE, 2" YLW/16 76029 X 76029		

WIRING GROUP – SCHEMATIC – NON-TRACTION

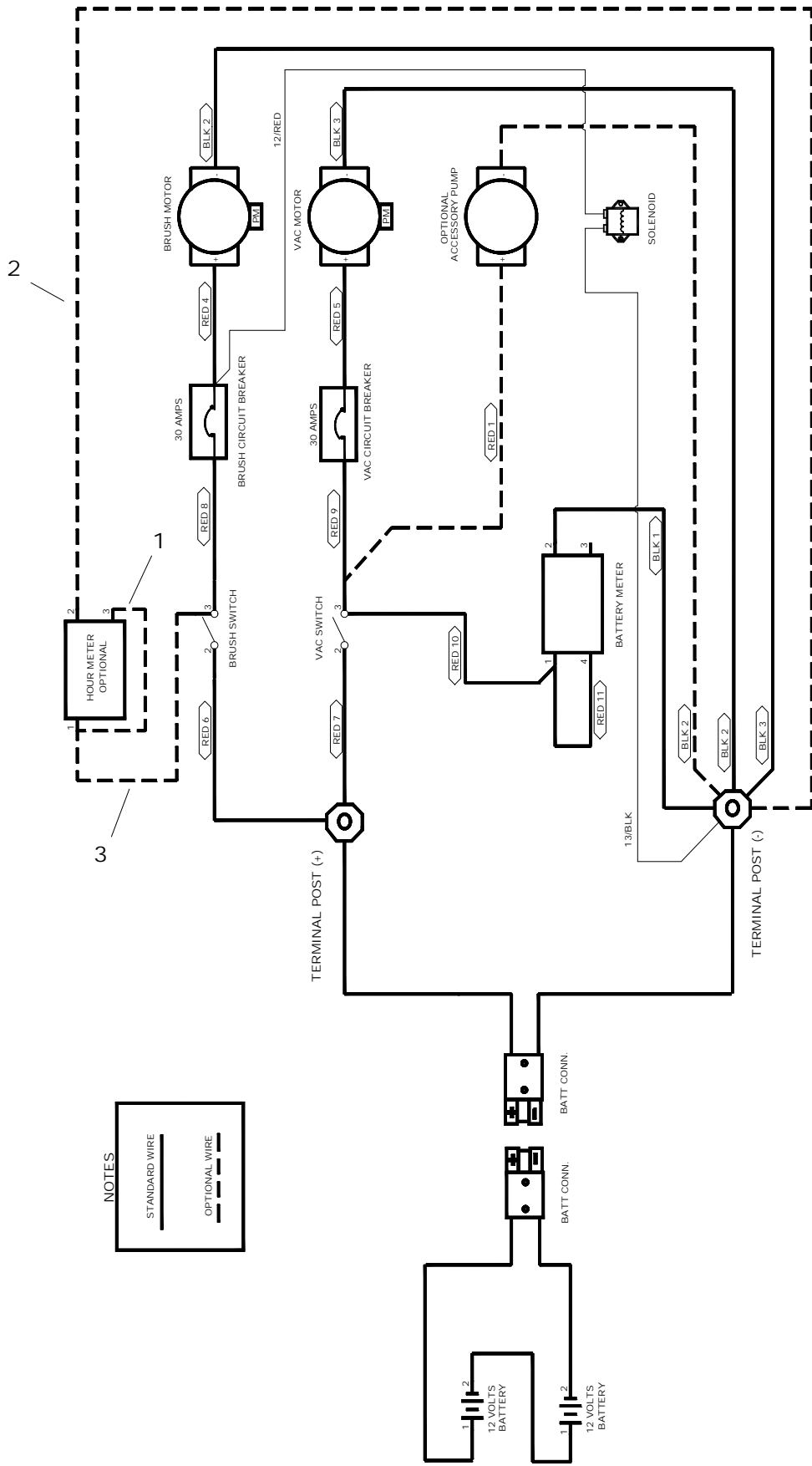

NOTES

STANDARD WIRE ———

OPTIONAL WIRE - - - -

WIRING GROUP – SCHEMATIC – NON-TRACTION

REF	PART NO.	PRV NO.	QTY	DESCRIPTION	SERIAL NO. FROM	NOTES:
1	86268650	88490	1	WIRE, 4" RED/18 76040 X 76040		
2	86266690	880034	1	WIRE, 6" BLACK/18 76011 X 76040		
3	86266840	880075	1	WIRE, 8" RED/18 76031 X 76031		

WIRING GROUP – SCHEMATIC – NON-TRACTION ONBOARD CHARGING

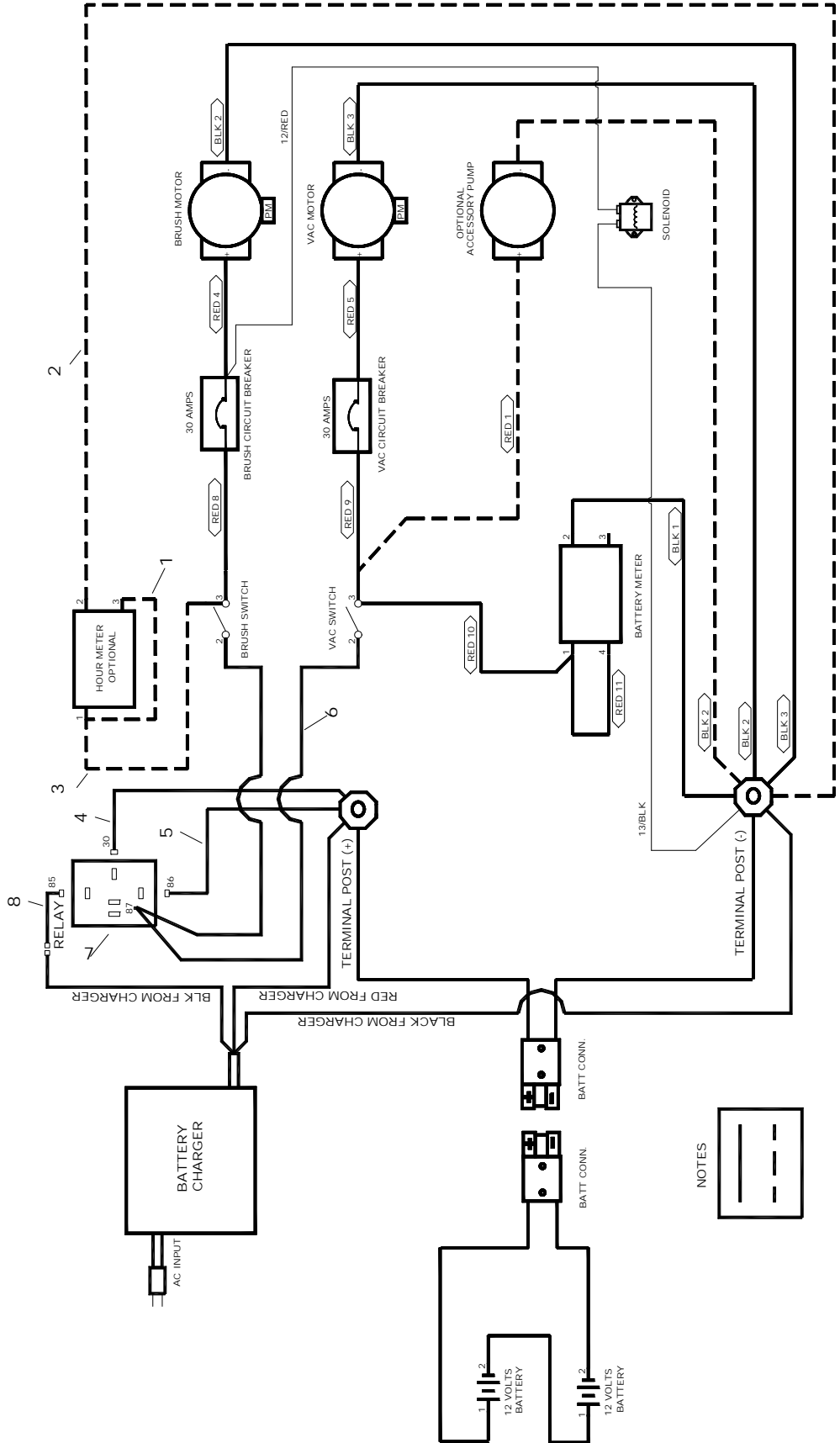

NOTES

WIRING GROUP – SCHEMATIC – NON-TRACTION ONBOARD CHARGING

REF	PART NO.	PRV NO.	QTY	DESCRIPTION	SERIAL NO. FROM	NOTES:
1	86268650	88490	1	WIRE, 4" RED/18 76040 X 76040		
2	86266690	880034	1	WIRE, 6" BLK/18 76011 X 76040		
3	86266840	880075	1	WIRE, 8" RED/18 76031 X 76031		
4	86268030	880456	1	WIRE, 14" RED/10 76081 X 76064		
5	86268040	880458	1	WIRE, 14" RED/14 76001 X 76029		
6	86268050	880459	1	WIRE, 14" RED/ 12 76064 X 76064		
7	86251390	67445	1	RELAY, 24 VDC 40A		
8	86268070	880463	1	WIRE, 2" YLW/16 76029 X 76029		

WIRING GROUP – SCHEMATIC – TRACTION

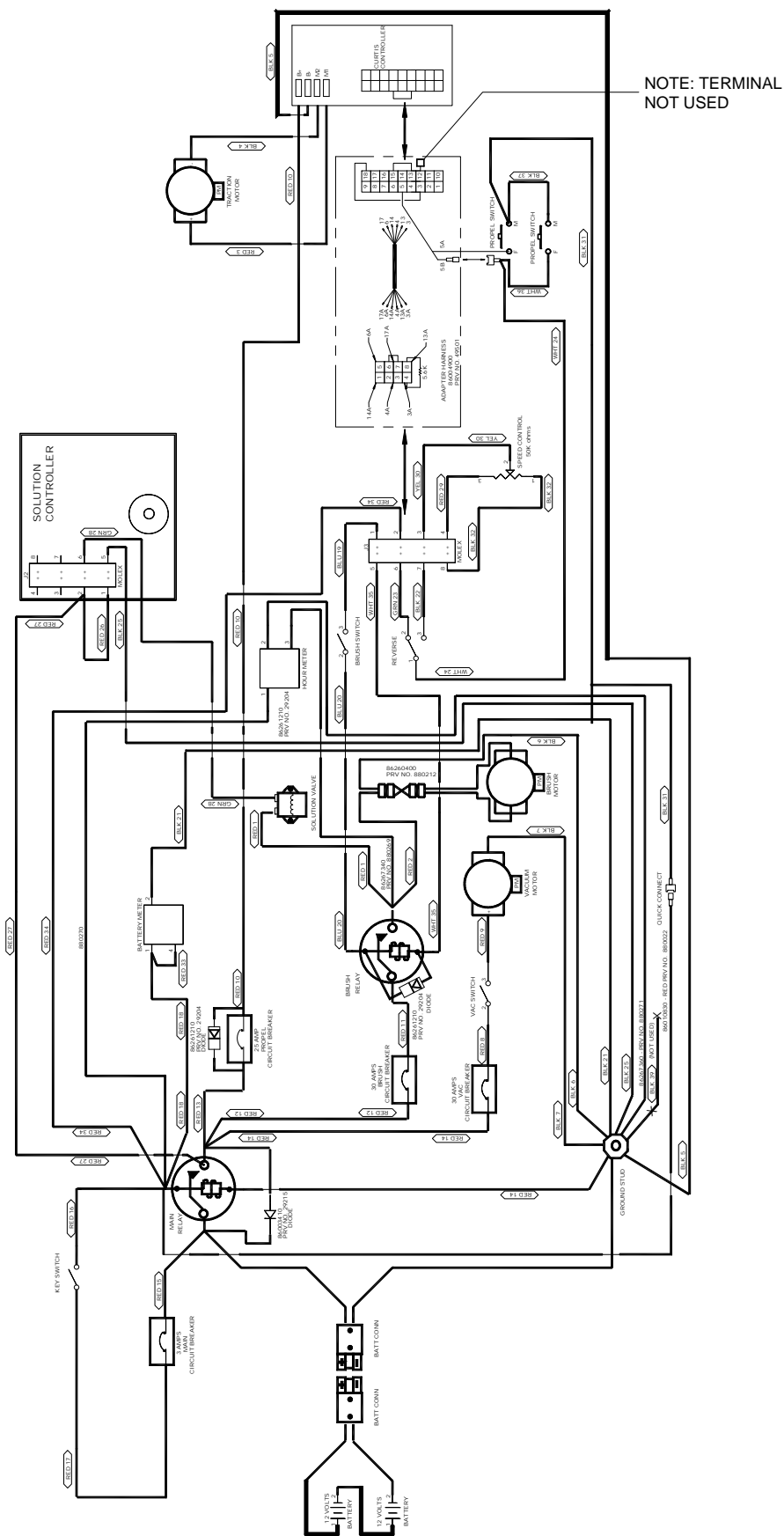

WIRING GROUP – SCHEMATIC – TRACTION

REF	PART NO.	PRV NO.	QTY	DESCRIPTION	SERIAL NO. FROM	NOTES:
1	86269300	88868	1	WIRE, 16" RED/18 STRIP X STRIP		
2	86261210	29204	2	DIODE ASM, 76008 X 76008		
3	86267340	880269	1	WIRE, 22" RED/18 76040 X 76075		
4	86004900	49501	1	HARNESS, ADAPTER SC20		

WIRING GROUP – SCHEMATIC – TRACTION AND ONBOARD CHARGING

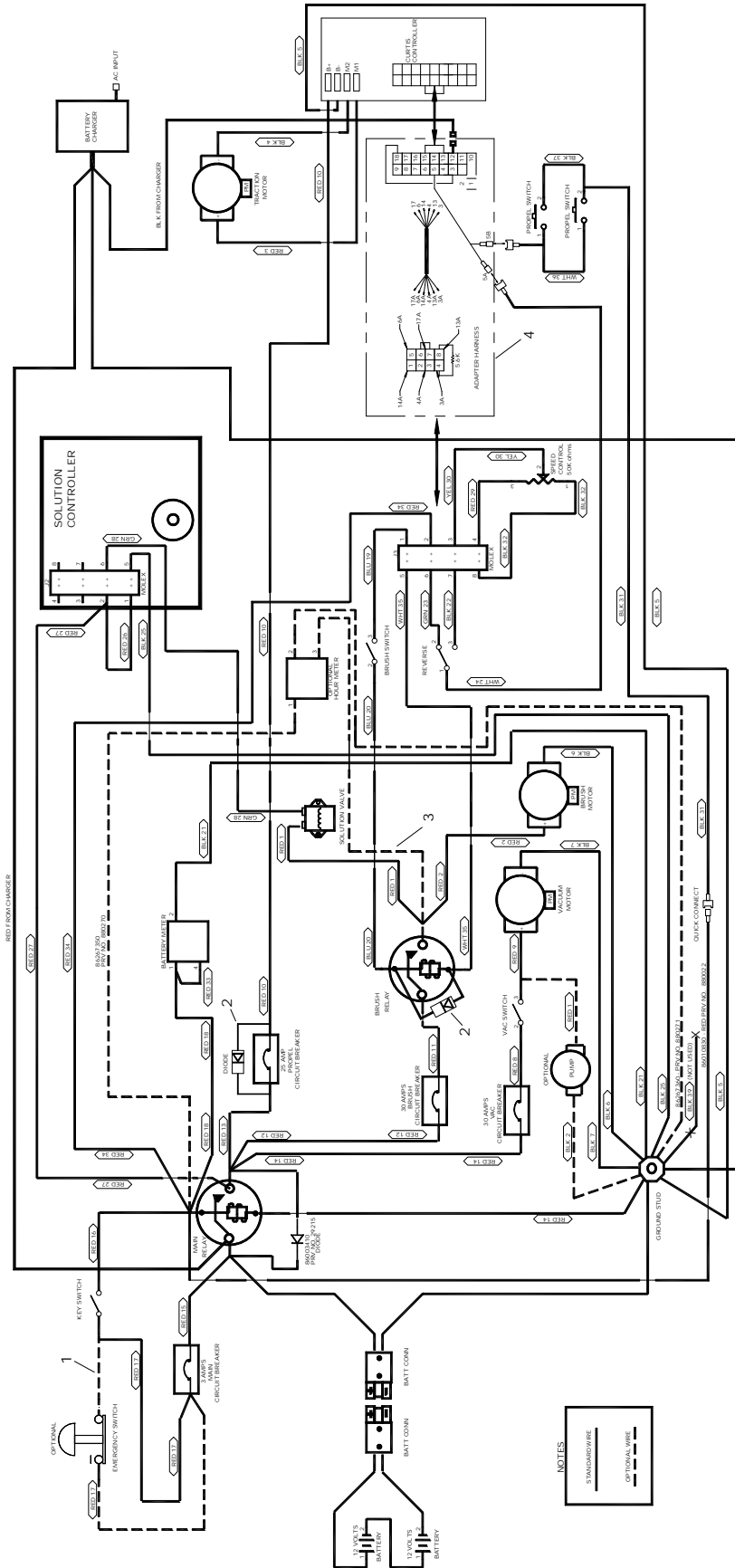

WIRING GROUP – SCHEMATIC –TRACTION AND ONBOARD CHARGING

REF	PART NO.	PRV NO.	QTY	DESCRIPTION	SERIAL NO. FROM	NOTES:
1	86269300	88868	1	WIRE, 16" RED/18 STRIP X STRIP		
2	86261210	29204	2	DIODE ASM, 76008 X 76008		
3	86267340	880269	1	WIRE, 22" RED/18 76040 X 76075		
4	86004900	49501	1	HARNESS, ADAPTER SC20		

WIRING GROUP – CONTROL PANEL - TRACTION

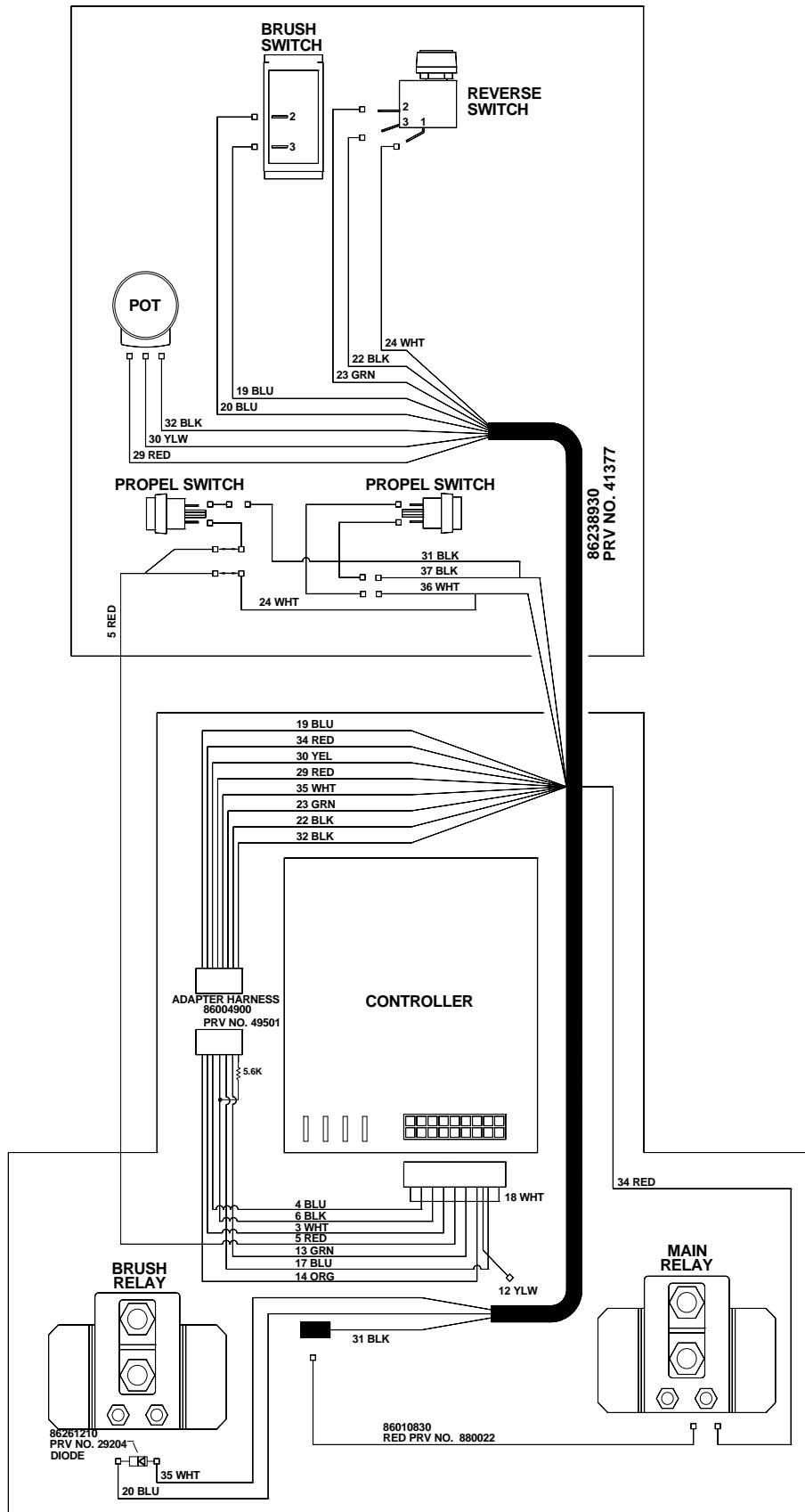

WIRING GROUP – CONTROL PANEL- TRACTION

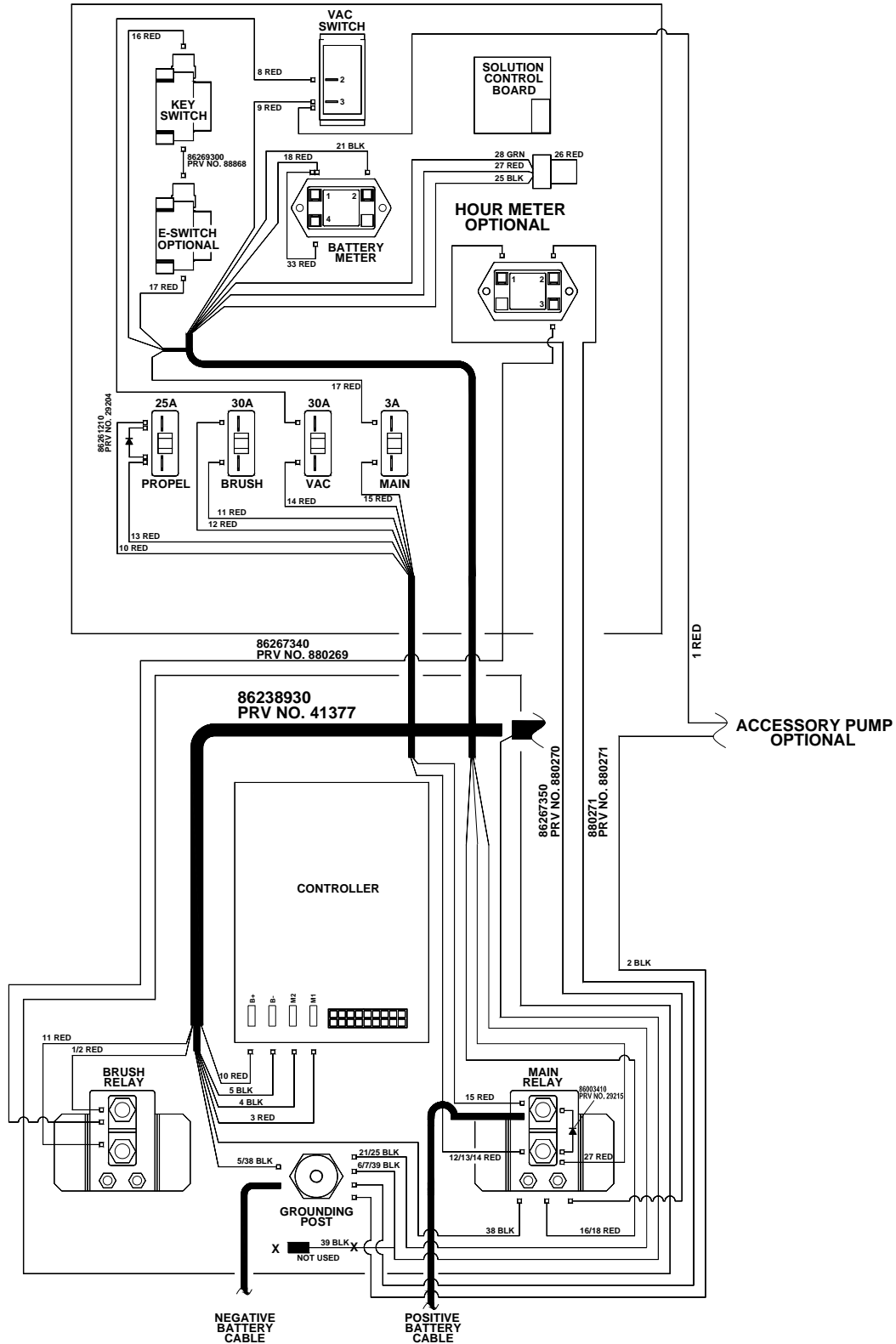

WIRING GROUP - MAIN HARNESS - TRACTION

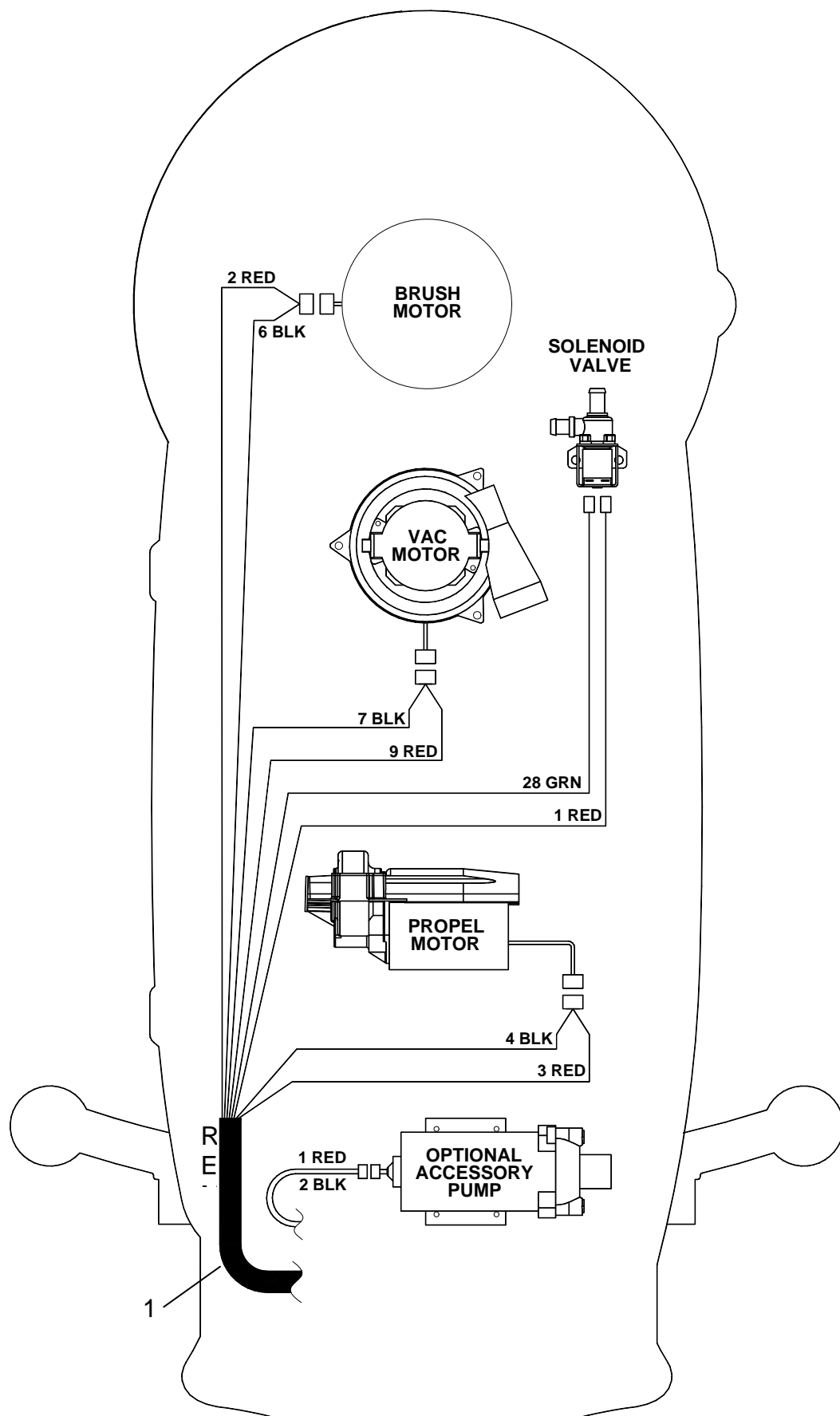

WIRING GROUP - MAIN HARNESS - TRACTION

REF	PART NO.	PRV NO.	QTY	DESCRIPTION	SERIAL NO. FROM	NOTES:
1	86238930	41377	1	HARNESS, SC20T MAIN		
2	86261210	29204	2	DIODE ASM, 76008 X 76008		NOT SHOWN
3	86003410	29215	1	DIODE ASM, 76075 X 76065		NOT SHOWN

EMERGENCY STOP OPTION

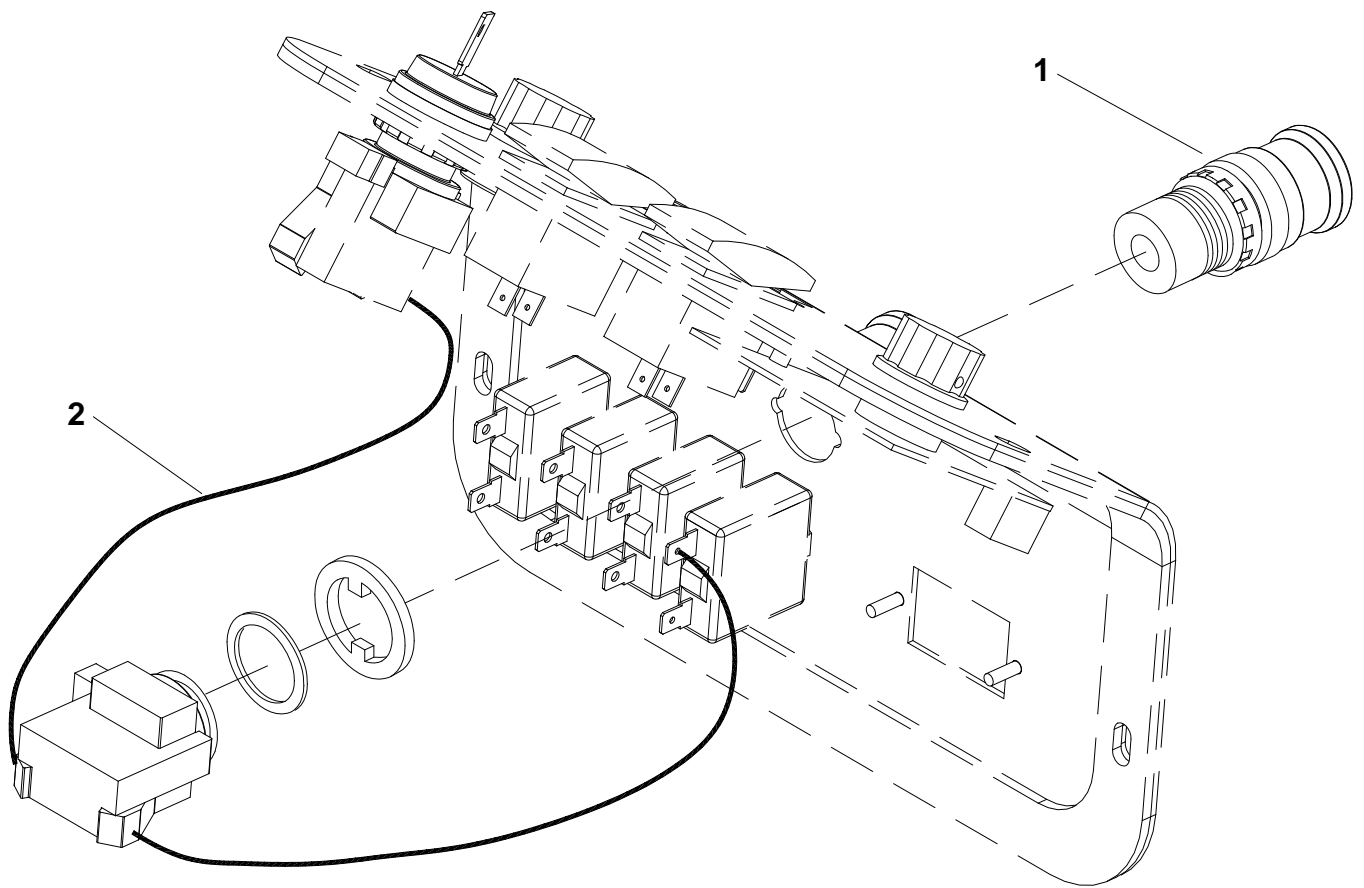

EMERGENCY STOP OPTION

REF	PART NO.	PRV NO.	QTY	DESCRIPTION	SERIAL NO. FROM	NOTES:
1	86007180	72160	1	SWITCH, EMERGENCY STOP		
2	86269300	88868	1	WIRE, 16" RED/18 STRIP X STRIP		

ACCESSORY PUMP OPTION

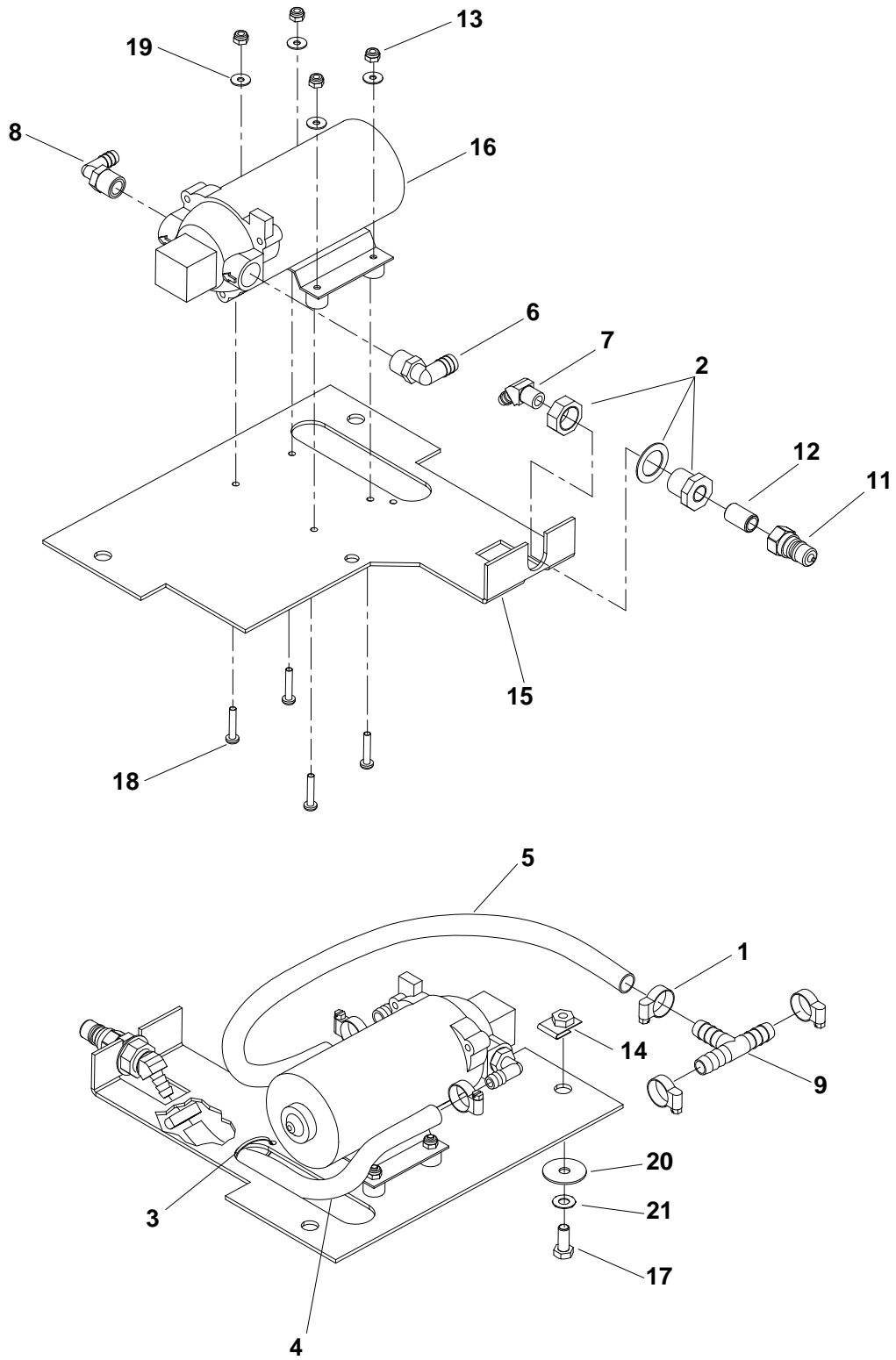

ACCESSORY PUMP OPTION

REF	PART NO.	PRV NO.	QTY	DESCRIPTION	SERIAL NO. FROM	NOTES:
1	86233150	20042	6	CLAMP, 3/8 HOSE (D-SLOT)		
2	86002470	22072	1	COUPLING, 1/4 ANCHOR W/1" HEX		
3	86264920	27049	1	CABLE TIE, 7" UL/CSA		
4	86281770	39500	1	HOSE, 3/8" NYLOBRAID X 15"		
5	86282720	82859	1	HOSE, 1/2 NYLOBRAID X 20"		
6	86197940	40027	1	HOSEBARB, 3/8MPTX1/2 90D DL		
7	86197620	40038	1	HOSEBARB, 1/4MPT X 3/8 45D DL		
8	86001550	40043	1	HOSEBARB, 3/8MPT X3/8 90D		
9	86240410	40078	1	HOSEBARB, 1/2 TEE		
10	86238940	41378	1	HARNESS, PUMP		NOT SHOWN
11	86005580	56012	1	NIPPLE, 1/4 FPT QD		
12	86005590	56014	1	NIPPLE, 1/4 CLOSE		
13	86005640	57030	4	NUT, 10-32 HEX NYLOCK		
14	86271820	57270	3	NUT, 5/16-18 CAPTIVE "J" PLTD		
15	86081860	62843	1	PLATE, PUMP MOUNT		
16	86026370	65180	1	PUMP ASM, 24V ACCESSORY		
17	86006760	70305	3	SCR, 5/16-18 X 3/4HHCSGR5PLTDL		
18	86006830	70386	4	SCR, 10-32 X 1.0 PPHMS		
19	86010650	87018	4	WASHER, #10 X 9/16 OD		
20	86010670	87029	3	WASHER, 5/16 FLAT SS		
21	86279130	87083	3	WASHER, 5/16 SPLIT LOCK PLTD		

SUGGESTED SPARE PARTS

PART NO.	PRV NO.	DESCRIPTION	SERIAL NO. FROM	NOTES:
86216150	140588	BRUSH SET, 24V TRANSAXLE		
86135370	14548	BRUSH SET, 24V 3ST VAC AMETEK		
86135310	140686	BRUSH SET, 24V/36V VAC WINDSOR	*(5)	
86001910	14606	BREAKER, 30A 50VDC CIRCUIT		
86001920	14607	BREAKER, 25A 50VDC CIRCUIT		
86001970	14695	BRUSH SET, IMPERIAL 53185/630		
86002000	14717	BREAKER, 3 AMP		
86002510	23125	WIRE 4X15 BCLAMPXBCLAMP		
86002540	23174	WIRE ASM 2X21 BATT W/ANDERSON		
86003180	27870	CABLE, .09X29, 0707,SS,LB,E-E		
86232180	27877	CAP, 3 INCH MPT		
86002800	270121	CABLE, .062X43 SS PUSH/PULL	*(3)	
86236400	34366	FLOAT SHUT-OFF		
86237230	35087	GASKET, 5.7 VAC MOTOR		
86003980	35249	GASKET, SQG .13 THK X 8.00 LG		
86004790	48012	KNOB, 5/16-18 4 PRONG		
86006360	67118	RELAY, 24VDC SOLENOID		
86007220	72166	SWITCH, SPST MOMENTARY		
86007140	72130	SWITCH, SPST 2-POSITION ROCKER		
86007260	730003	BLADE, SQUEEGEE (URETHANE)		
86007840	73790	SKIRT, SHROUD 3.25 X 58.0 L		
86007970	73864	STRAINER, 3/8 IN. NPT 60 MESH		
86252520	80885	SAFETY DECAL, BATTERY CAUTION		
86252530	81494	SAFETY DECAL, SOLUTION WARNING		
86037860	980300	MANUAL, CURTIS 1604/1608 CHRGR		

* SEE SERIAL NUMBER PAGE



Manufacturers of Innovative Building Maintenance Equipment

EC Declaration of Conformity

We herewith declare, Windsor Industries, Inc.
1351 W. Stanford Ave.
Englewood, CO 80110-5545 USA

that the following product complies with the appropriate essential health and safety requirements of the relevant EC Directives listed below, based on the relevant sections of the applicable EC standards and other normative documents.

Product: Saber Compact 20 Traction
Saber Compact 20 Deluxe
Quadra Saber Compact 20 Traction
Quadra Saber Compact 20 Deluxe

Product Identification: Rated 24 VDC 50 A

Trademark:



Model/Type Ref.: SC20T QSC20T
SCX20T QSCX20T

Product Description: This product is a battery powered, self-propelled, wet floor scrubber intended for commercial use.

Applicable EC Directives: EC Machinery Directive
(89/392/EEC & 91/368/EEC & 93/44/EEC & 93/68/EEC)
EC Low Voltage Directive
(73/23/EEC & 93/68/EEC)
EC Directive of Electromagnetic Compatibility
(89/336/EEC & 93/68/EEC)

Applicable Harmonized Standards: EN 60335-1: 1991
EN 60335-2-67: 1992
EN 60335-2-72: 1995
EN 50081-2: 1993
EN 55011: 1990
EN 50082-2: 1994
EN 61000-4-2: 1995
EN 61000-4-3: 1997

J. Sanford Davis
Authorized Signature

30 March 2000
Date

Windsor Industries, Inc.,
1351 West Stanford Avenue,
Englewood, CO 80110 USA
303.762.1800 FAX 303.762.0817
Title of Signature: Vice President, Windsor Industries, Inc.



Manufacturers of Innovative Building Maintenance Equipment

EC Declaration of Conformity

We herewith declare, Windsor Industries, Inc.
1351 W. Stanford Ave.
Englewood, CO 80110-5545 USA

that the following product complies with the appropriate essential health and safety requirements of the relevant EC Directives listed below, based on the relevant sections of the applicable EC standards and other normative documents.

Product: Saber Compact 20
Quadra Saber Compact 20

Product Identification: Rated 24 VDC 45 A

Trademark:



Model/Type Ref.: SC20
QSC20

Product Description: This product is a battery powered, self-propelled, wet floor scrubber intended for commercial use.

Applicable EC Directives: EC Machinery Directive
(89/392/EEC & 91/368/EEC & 93/44/EEC & 93/68/EEC)
EC Low Voltage Directive
(73/23/EEC & 93/68/EEC)
EC Directive of Electromagnetic Compatibility
(89/336/EEC & 93/68/EEC)

Applicable Harmonized Standards: EN 60335-1: 1991
EN 60335-2-67: 1992
EN 60335-2-72: 1995
EN 50081-2: 1993
EN 55011: 1990
EN 50082-2: 1994
EN 61000-4-2: 1995
EN 61000-4-3: 1997

J. Searful Jr.
Authorized Signature

30 March 2000
Date

Windsor Industries, Inc.,
1351 West ~~Stanford Ave.~~ **Title of Signatory:** Vice President, Windsor Industries, Inc.
Englewood, CO 80110 USA
303.762.1800 FAX 303.762.0817

SERIAL NUMBERS

REF. NO.	MODEL: SERIAL #
1	SC20, SCC20, SC20T, SCC20T, SCX20T, SCXC20T: 1000097107
2	SC20T, SCC20T, SCX20T, SCXC20T: 1000136001
3	SC20, SCC20: 1000149238
4	SC20, SCC20: 10052190000134, 10052230000101
5	SC20, SCC20, SC20T, SCC20T, SCX20T, SCXC20T: 1000122411
6	SC20, SCC20: 100011685
7	SC20T, SCC20T, SCX20T, SCXC20T: 1000049753
8	SC20T, SCC20T, SCX20T, SCXC20T: 1000060885
9	SCC20: 10052230000227 , SCC20T: 10052240000144 , SCXC20T: 10052420000121