

# CONTROL HANDLE

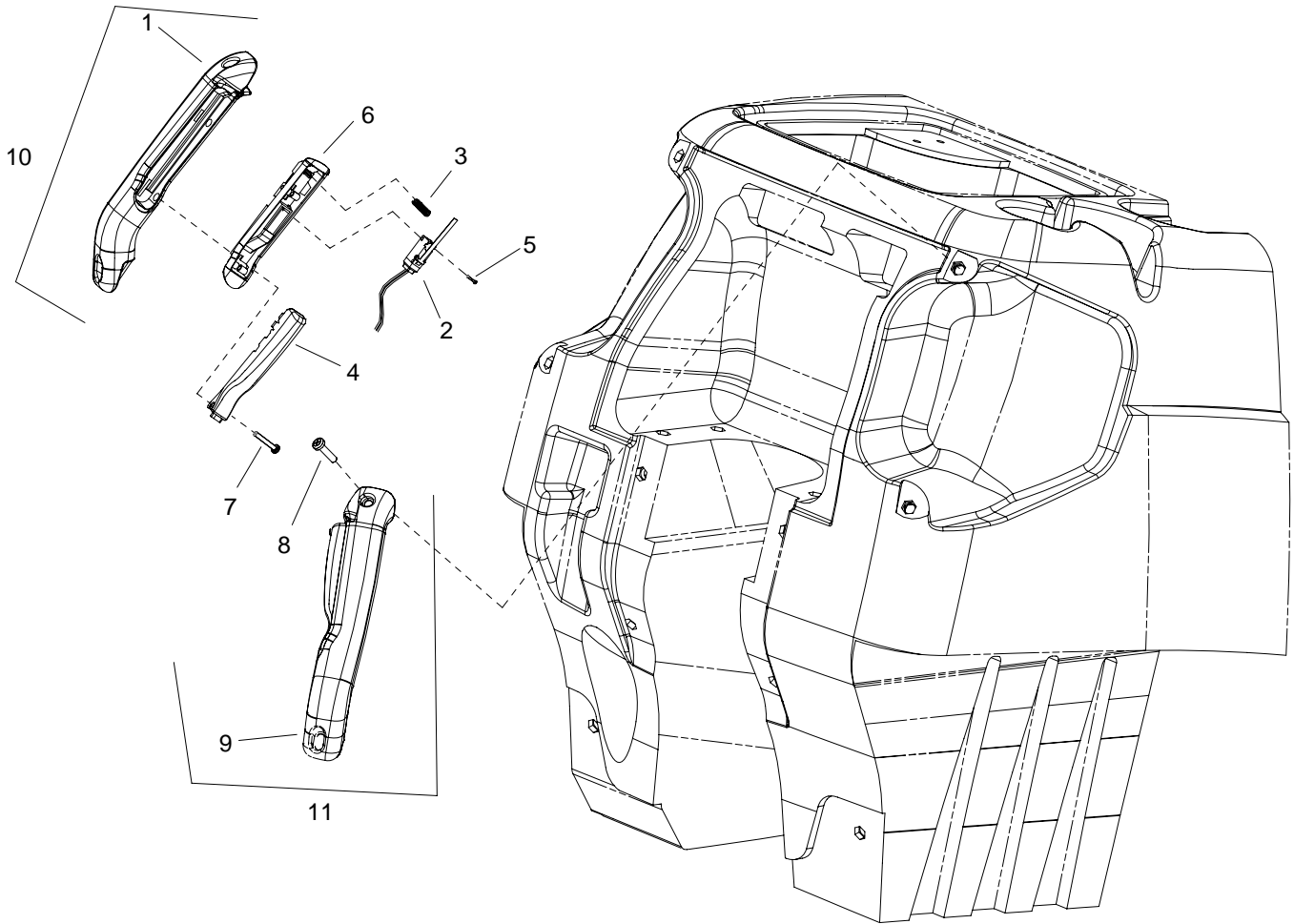

## CONTROL HANDLE

REF	PART NO.	PRV NO.	QTY	DESCRIPTION	SERIAL NO. FROM	NOTES:
1	86238730	38307	1	HANDLE, LEFT		
2	86257230	730125	2	SWITCH, SPST MOM NO W/LEVER		
3	86254920	730153	2	SPRING, COMP .240D X 1.25 X .018		
4	86231480	140504	2	BUTTON, PROPEL		
5	86277070	70784	2	SCR, 4-40 X 5/8 PPHMS		
6	86240990	41431	2	HOUSING, BUTTON		
7	86277060	70783	4	SCR, 8-32 X 7/8 PHTC TYPE 23		
8	86277050	70782	4	SCR, 5/16-18 X 3/4 SHCS NP SS		
9	86238740	38308	1	HANDLE, RIGHT		
10	86004120	38312	-	PROPEL HANDLE ASM, LEFT		SERVICE ONLY
11	86004130	38313	-	PROPEL HANDLE ASM, RIGHT		SERVICE ONLY

# COVER (FRONT) & TANK MOUNT

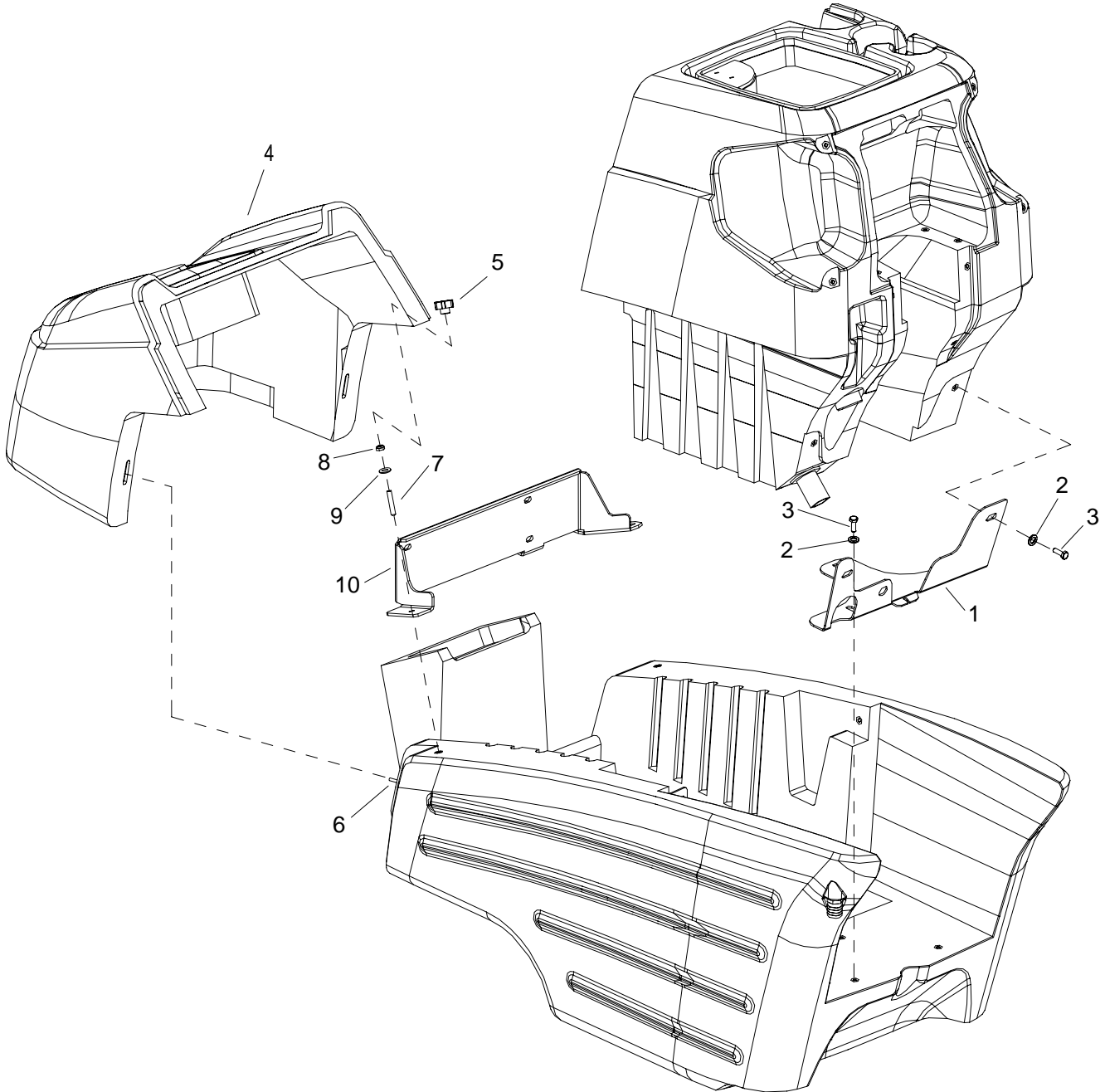

## COVER (FRONT) & TANK MOUNT

REF	PART NO.	PRV NO.	QTY	DESCRIPTION	SERIAL NO. FROM	NOTES:
1	86070150	140574	1	BRKT, TANK MOUNT 24V		
2	86010670	87029	4	WASHER, 5/16 FLAT SS		
3	86276780	70728	4	SCR, 5/16-18 X 3/4 HHCS SS		
4	86062530	27925	1	COVER, FRONT, 24V GRY		
5	86004790	48012	2	KNOB, 5/16 -18 4 PRONG		
6	86276380	70639	2	SCR, 5/16-18 X 1.25 SSSCU		
7	86278080	70823	2	SET SCR, 5/16-18 X 1.75 CP SS		
8	86271840	57285	2	NUT, 5/16-18 HEX NYLOCK THIN SS		
9	86010670	87029	2	WASHER, 5/16 FLAT SS		
10	86068150	140706	1	BRACKET, TANK SUPPORT	*	

# COVER (TOP) & TANK MOUNT

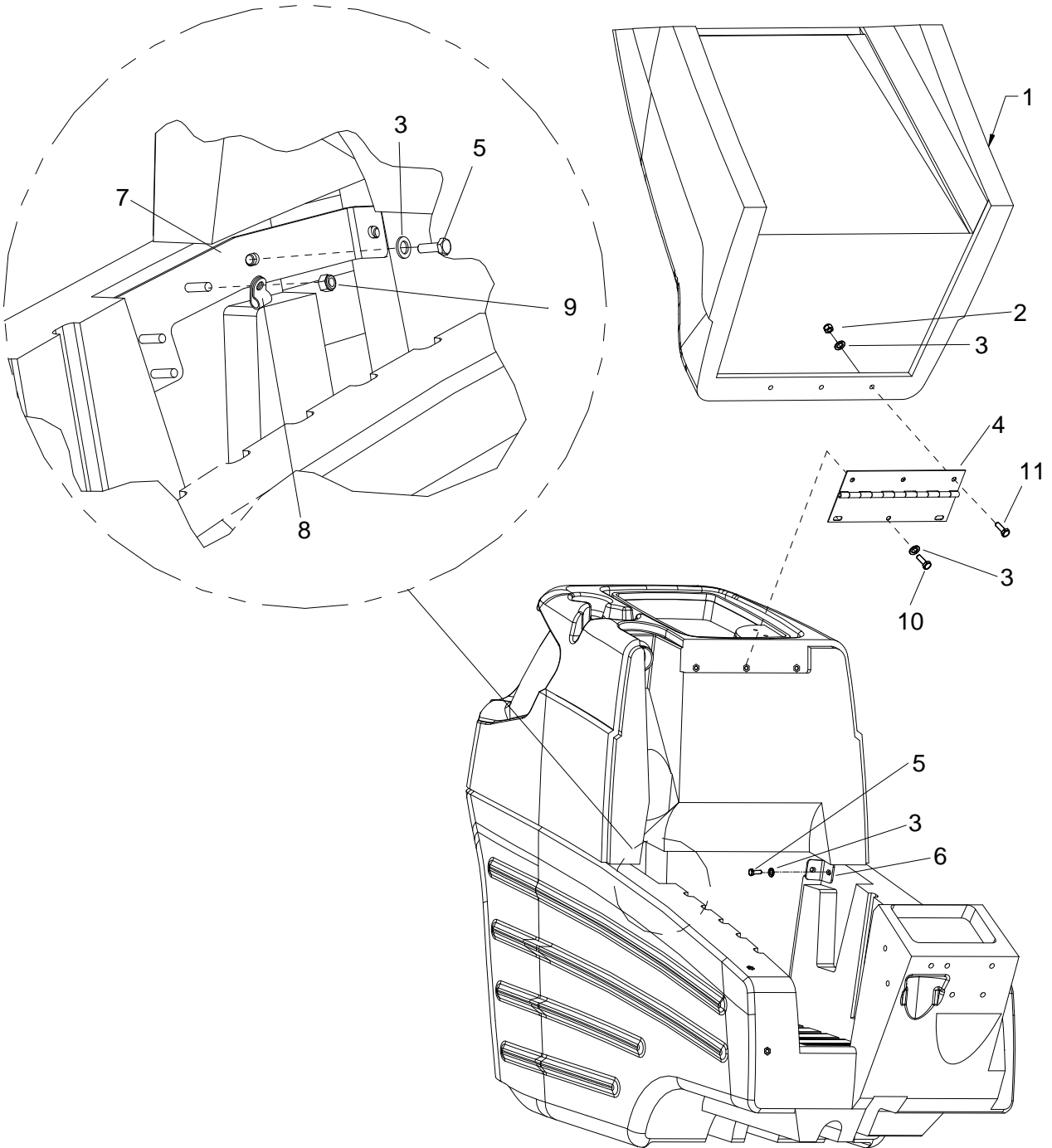

## COVER (TOP) & TANK MOUNT

REF	PART NO.	PRV NO.	QTY	DESCRIPTION	SERIAL NO. FROM	NOTES:
1	86062540	27926	1	COVER, TOP 24V GRY		
2	86271840	57285	3	NUT, 5/16-18 HEX NYLOCK THIN SS		
3	86010670	87029	10	WASHER, 5/16 FLAT SS		
4	86239630	41429	1	HINGE, COVER TO TANK		
5	86276780	70728	4	SCR, 5/16-18 X 3/4 HHCS SS		
6	86073700	140484	1	BRACKET, TANK LEFT		
7	86069630	140485	1	BRACKET, TANK RIGHT		
8	86233390	80887	1	CLAMP, 7/8 DIA "P" CUSHIONED		
9	86271870	57290	1	NUT, 1/4-20 HEX NYLOCK THIN SS		
10	86276490	70670	3	SCR, 5/16 -18 X 5/8 HHCS SS		
-	86247670	58004	1	NET, CARGO W/HOOKS		NOT SHOWN
11	86276780	70728	3	SCR, 5/16 -18 X 3/4 HHCS SS		

**DECAL**

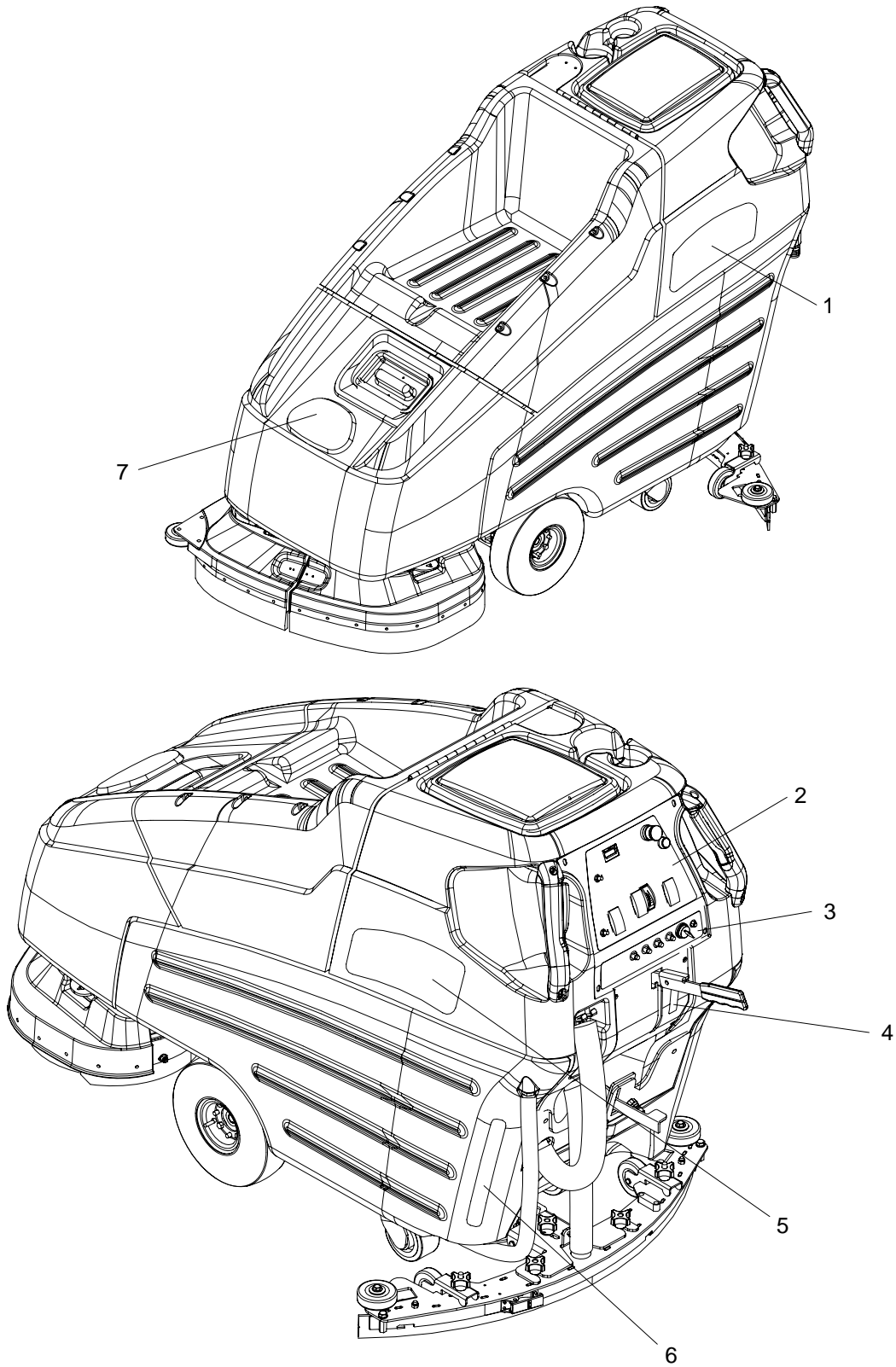

**DECAL**

REF	PART NO.	PRV NO.	QTY	DESCRIPTION	SERIAL NO. FROM	NOTES:
1	86243560	500573	1	LABEL, CUTTER RIGHT		
2	86243520	500564	1	LABEL, ELEC. PANEL 24V DELUXE		
3	86243530	500565	1	LABEL, ELEC. PANEL. LOWER 24V		
4	86243600	500578	1	LABEL, SQUEEGEE LEVER		
5	86243550	500572	1	LABEL, CUTTER LEFT		
6	86243180	500479	1	LABEL, SOLUTION FILL 24V		
7	86004970	50990	1	LABEL, WINDSOR LOGO DOMED		

# ELECTRICAL PANEL

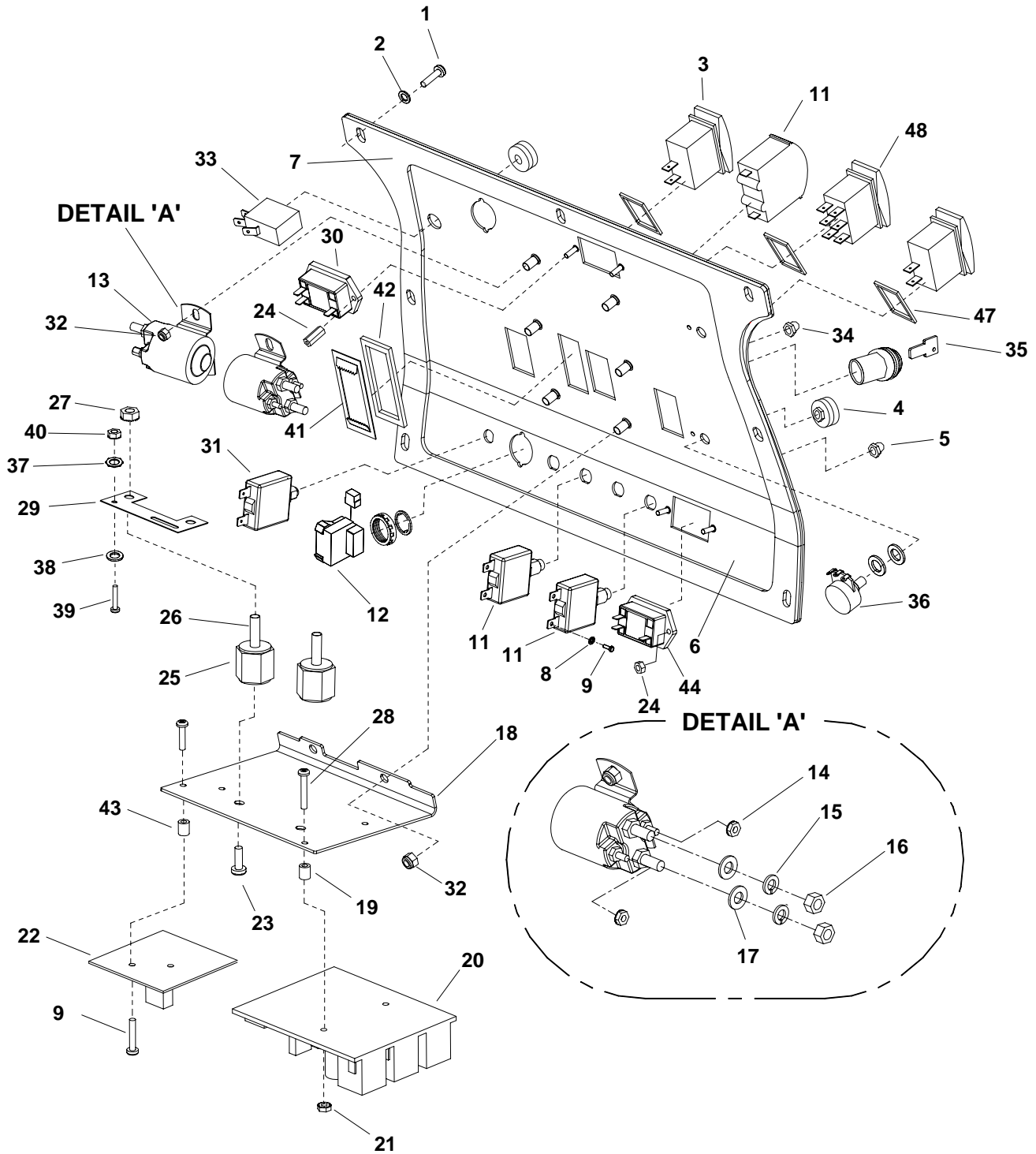

**ELECTRICAL PANEL**

REF	PART NO.	PRV NO.	QTY	DESCRIPTION	SERIAL NO. FROM	NOTES:
1	86276290	70626	7	SCR, #10 X 3/4 PPHST HI-LO BLK		
2	86294250	-	7	WASHER, .19 ID X .5 X .09TK BLK		
3	86007140	72130	2	SWITCH, SPST 2-POSITION ROCKER		
4	86242110	48088	2	KNOB, .90 OD X .25 COLLET		
5	86008900	80845	4	BOOT, SEAL-PUSH BUTTON 7/16-28		
6	86082180	62926	1	PLATE, ELEC. PANEL 24V DELUXE		
7	86237800	35261	1	GASKET, ELEC PLATE 24V		
8	86279300	87134	8	WASHER, #6 LOCK		
9	86273990	70067	12	SCR, 6-32 X 3/8 PPHMS SS		
10	86001910	14606	4	BREAKER, 30A 50VDC CIRCUIT		
11	86246940	54156	1	METER, 0-50 AMP DC		
12	86007170	72159	1	SWITCH KEY TWO POSITION		
13	86006420	67393	2	RELAY, 24VDC 100A		
14	86005700	57104	4	NUT10-32 W/STAR WASHER PLTD		
15	86279480	87166	4	WASHER, 5/16 EXT LOCK PLTD		
16	86271080	57117	4	NUT, 5/16-24 HEX PLTD		
17	86010760	87142	2	WASHER, .344 X .69 X .066 FLAT PLT		
18	86082820	66353	1	PLATE, ELECT. PANEL, BACK		
19	86254440	73734	2	SPACER, .166 ID X .313 OD X .375 L AL		
20	86002950	27695	1	CONTROLLER, 24VDC PROPEL MOTOR		
21	86270850	57026	2	NUT, 8-32 HEX NYLOCK SS		
22	86002350	27944	1	CIRCUIT BOARD, SOL FLOAT WIRED		
23	86276880	70751	2	SCR, 1/4-20 X 3/8 HHCS SS		
24	86255900	73538	3	STANDOFF, 6-32 x 5/8 HEX NYL		
25	86255910	73659	2	STANDOFF, 1/4-20 X 1.0 HEX INS		
26	86006850	70393	2	SET SCR, 1/4-20 X 1.25 L		
27	86005710	57105	2	NUT, 1/4-20 HEX W/STAR WASHER		
28	86273910	70045	2	SCR, 8-32 X 1 PPHMS SS		
29	86253630	73987	1	SHUNT, DC AMM. 25 AMP, 50MV		
30	86005520	54145	1	METER, 24V BATTERY CHARGE LEVEL		
31	86002000	14717	1	BREAKER, 3 AMP 1681-090-300		
32	86271870	57290	6	NUT, 1/4-20 HEX NYLOCK THIN SS		
33	86257030	72168	1	SWITCH, MOMENTARY, DPST		
34	86002010	14942	1	BOOT, 3/8 CIRCUIT BRAKER		
35	86004860	48073	1	KEY SWITCH		
36	86006310	66335	1	POTENTIOMETER, 50K OHMS		
37	86279020	87026	2	WASHER, #6 LOCK EXT STAR SS		
38	86279600	87187	2	WASHER, #6 FLAT BRASS		
39	86276250	70615	2	SCR, 6-32 X 3/8 SRHMS BR		
40	86271790	57256	2	NUT, 6-32 HEX BRASS		
41	86249290	62283	1	PLATE, METER RETAINING		
42	86237830	35264	1	GASKET, AMP METER		
43	86255890	730164	2	STANDOFF, 6-33 X 1.0 HEX NYL		
44	860055220	54154	1	METER, 24V BATTERY CHARGE LEVEL		
45	86267340	880269	2	WIRE, 22" RED/18 76040 X 76075		
46	86267360	880271	1	WIRE, 14" BLK/18 76011 X 76040		
47	86238030	36235	3	GASKET, SWITCH CARLING		
48	86007210	72165	1	SWITCH, DPDT 3-POSITION ROCKER		

# LIFT HANDLE

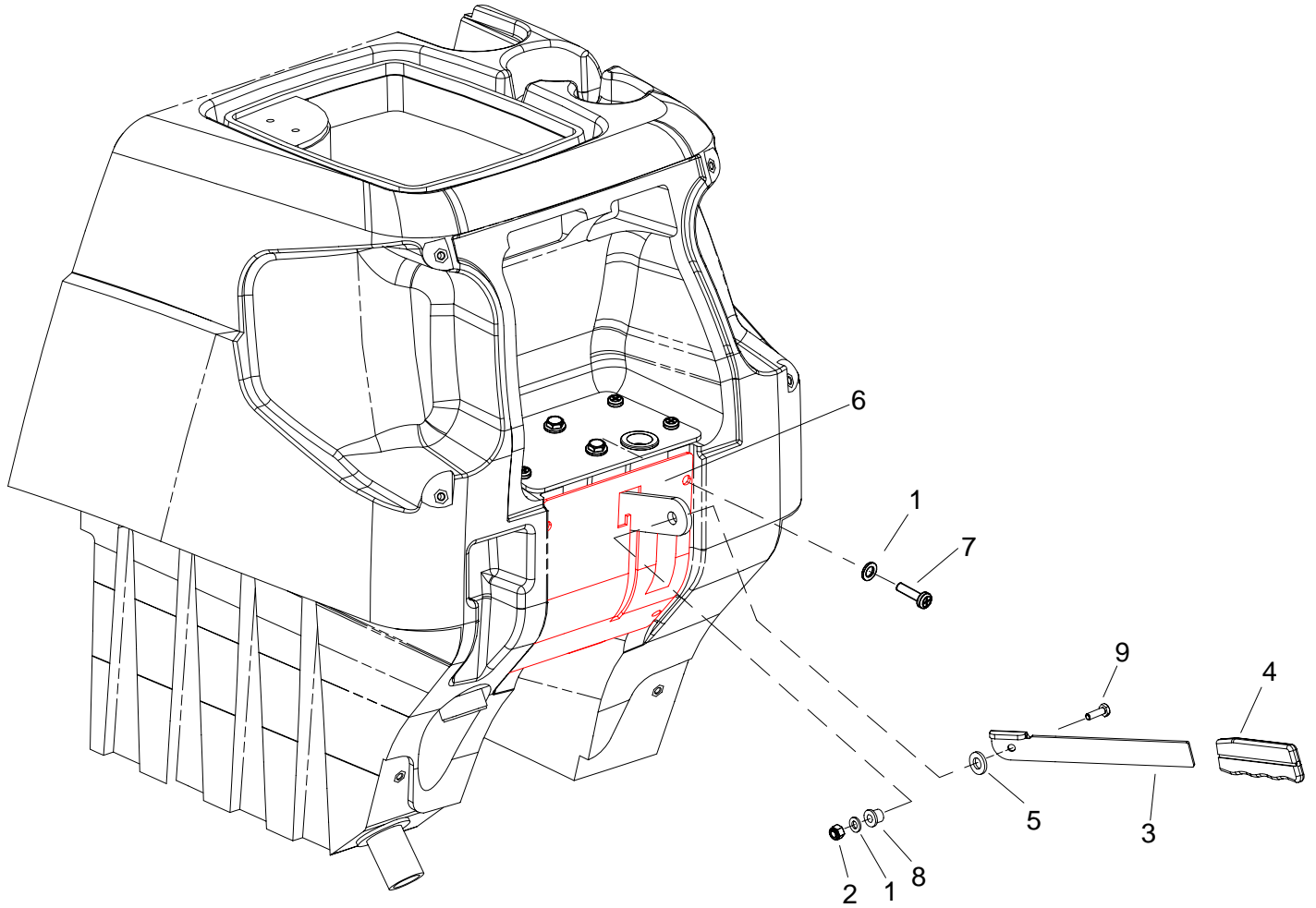

**LIFT HANDLE**

REF	PART NO.	PRV NO.	QTY	DESCRIPTION	SERIAL NO. FROM	NOTES:
1	86010670	87029	5	WASHER, 5/16 FLAT SS		
2	86271840	57285	1	NUT, 5/16-18 HEX NYLOCK THIN SS		
3	86066860	140537	1	BAR, SQG LIFT SWING 36V		
4	86238360	36215	1	GRIP, 3/16 X 1.0 ORANGE		
5	86259400	87205	1	WASHER, THRUST .51ID X 1OD BRO		
6	86082390	62961	1	PLATE, LEVER NOTCH DLX		
7	86276780	70728	4	SCR, 5/16-18 X 3/4 HHCS SS		
8	86228840	09124	1	BEARING, FLANGED .314 ID X .502 OD		
9	86006930	70514	1	SCR, 5/16-18 X 1.00 BSHCS SS		

# LIFT HANDLE LINKAGE

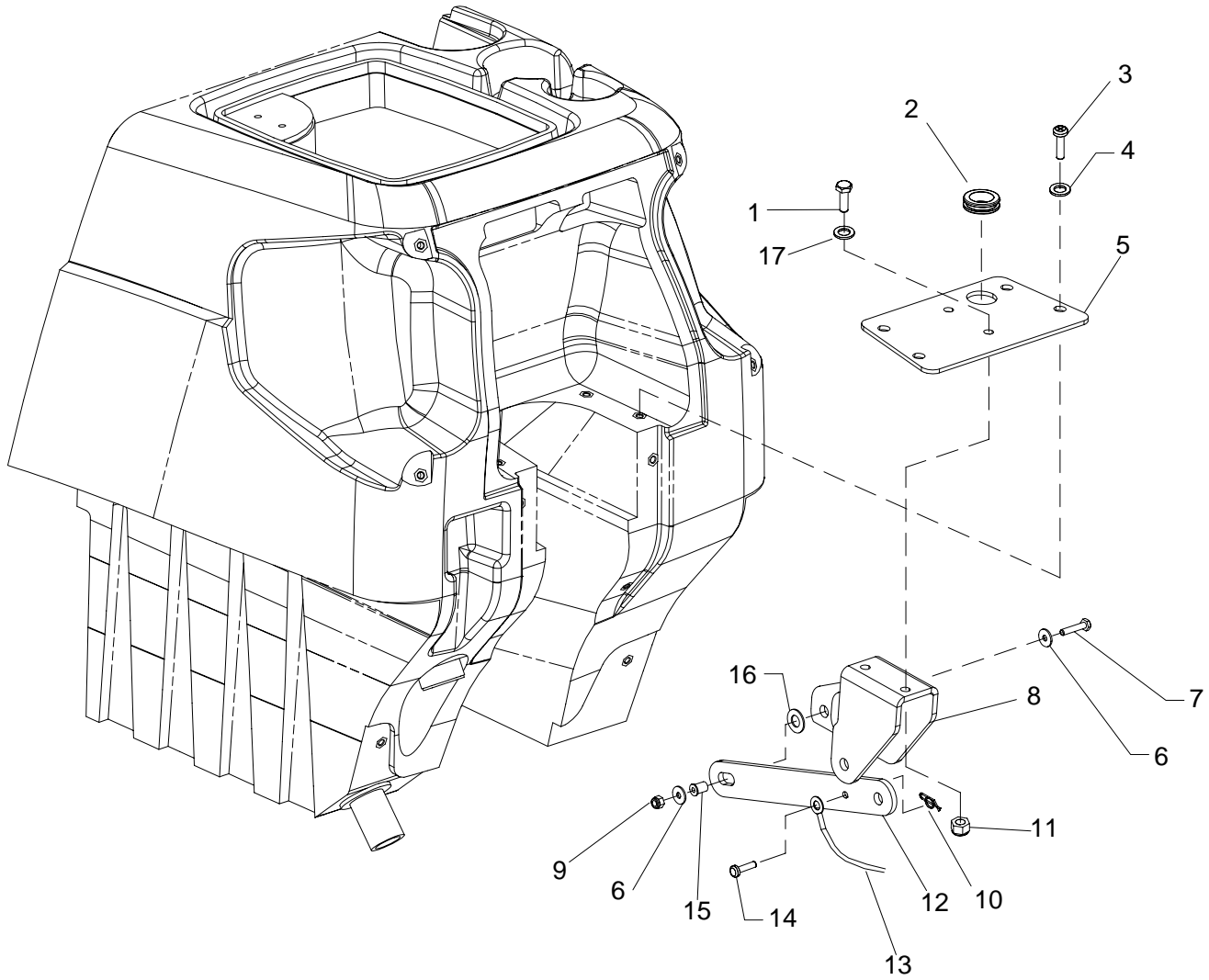

## LIFT HANDLE LINKAGE

REF	PART NO.	PRV NO.	QTY	DESCRIPTION	SERIAL NO. FROM	NOTES:
1	86276920	70755	2	SCR, 3/8-16 X 1 HHCS SS NP		
2	86238430	36191	1	GROMMET, 1.00ID 3/16 GRIP		
3	86276780	70728	4	SCR, 5/16-18 X 3/4 HHCS SS		
4	86010670	87029	4	WASHER, 5/16 FLAT SS		
5	86082270	62946	1	PLATE, PIVOT		
6	86010630	87013	2	WASHER, 1/4ID X 5/8OD SS		
7	86273820	70019	1	SCR, 1/4-20 X 1.25 HHCS SS		
8	86069610	140482	1	BRACKET, SCRUB DECK PIVOT 24V		
9	86271870	57290	1	NUT, 1/4-20 HEX NYLOCK THIN SS		
10	86008650	80604	1	COTTER, 1/4" RING		
11	86005630	57022	2	NUT, 3/8-16 HEX NYLOCK THIN SS		
12	86077480	51365	1	LINK, SQG LIFT FIXED		
13	86003240	27942	1	CABLE, .125 X 26.5 0707 SS LB E-E		
14	86009560	82053	1	PIN, CLEVIS 1/4" X .63" PLTD		
15	86228900	09138	1	BEARING, FLANGED .252ID X .503OD		
16	86259400	87205	1	WASHER, THRUST .51ID X 1OD BRO		
17	86278910	87003	2	WASHER, 3/8 ID X 7/8 OD SS		

# RECOVERY TANK

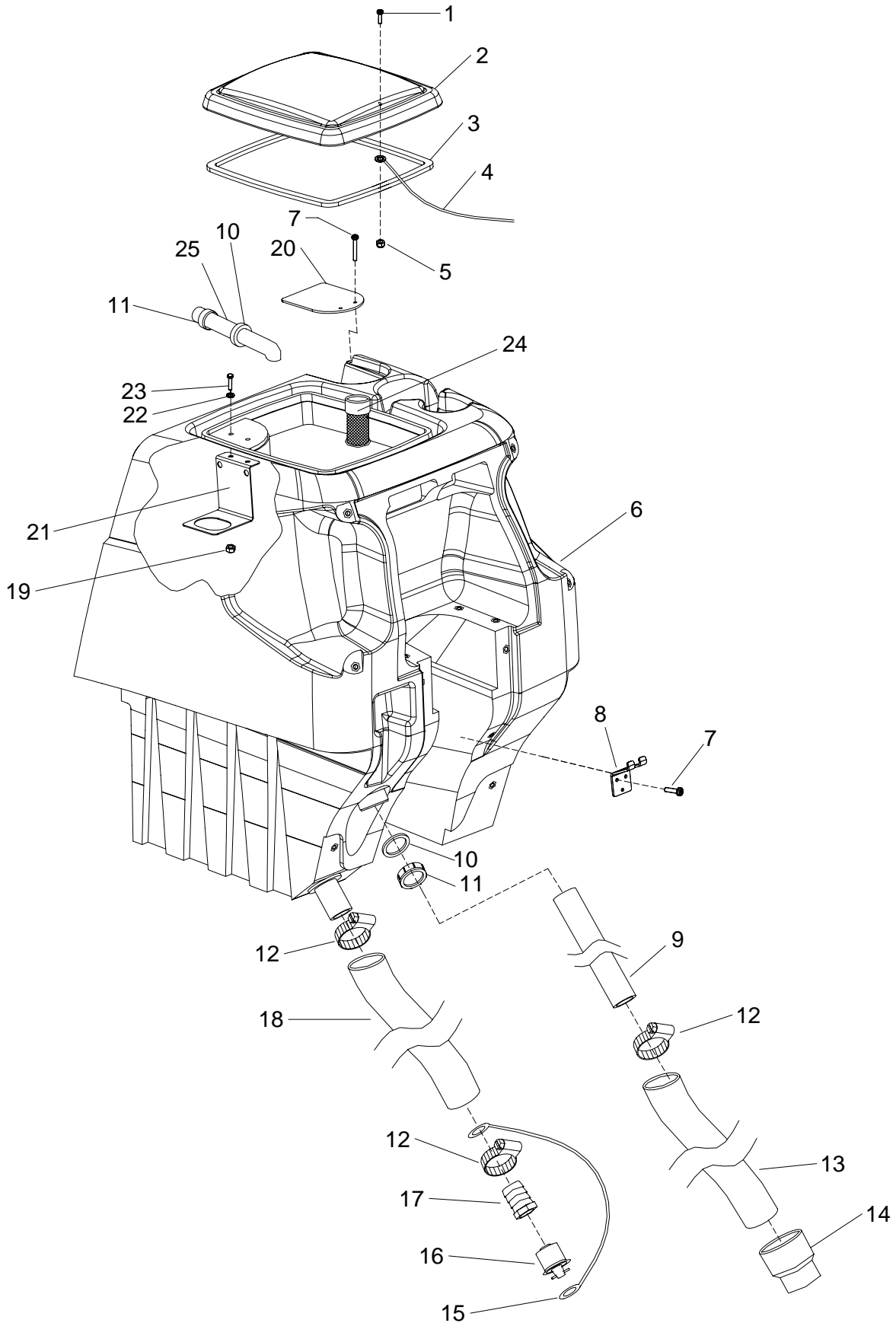

## RECOVERY TANK

REF	PART NO.	PRV NO.	QTY	DESCRIPTION	SERIAL NO. FROM	NOTES:
1	86273950	70056	1	SCR, 6-32 X 1/2 PPHMS		
2	86003340	28062	1	DOME, 13 X 11		
3	86003990	35250	1	GASKET, DOME		
4	86246080	51368	2	LANYARD, 18.0 W/ LOOP & EYE		
5	86270920	57049	1	NUT, 6-32 HEX NYLOCK SS		
6	86032540	75371	1	TANK, RECOVERY 24V GRY		
7	86276290	70626	5	SCR, #10 X 3/4 PPHST HI-LO BLK		
8	86001190	140133	1	BRACKET, RECOVERY HOSE MTG		
9	86089630	78490	1	TUBE, 1.5 PVC X 24.0		
10	86237650	35219	2	GASKET, 1-1/2 COMPRESSION		
11	86005660	57033	2	NUT, 1.5 SLIP JOINT		
12	86002400	20064	3	CLAMP, 2.0" WORM GEAR X .312W		
13	86004180	39315	1	HOSE, 1.5 BLK VAC X 28"		
14	86002840	27282	1	CUFF, 1.5 SLIP X 1.5 HOSE		
15	86008400	78499	1	TETHER, DRAIN PLUG		
16	86006240	66227	1	PLUG, DRAIN HOSE		
17	86004450	40019	1	HOSEBARB, 1.5 DOUBLE MCHD		
18	86004260	39472	1	HOSE, 1.5 X 24.0 DRAIN		
19	86271870	57290	2	NUT, 1/4-20 HEX NYLOCK THIN SS		
20	86075540	27941	1	COVER, VACUUM HOSE		
21	86069780	140511	1	BRACKET, VAC INTAKE		
22	86010630	87013	2	WASHER, 1/4ID X 5/8OD SS		
23	86273810	70018	2	SCR, 1/4-20 X 1 HHCS SS		
24	86236410	34394	1	FLOAT, VAC SHUT OFF		
25	86257860	78390	1	TUBE, 1.5 WASTE		

# SCRUB BRUSH/PAD DRIVER

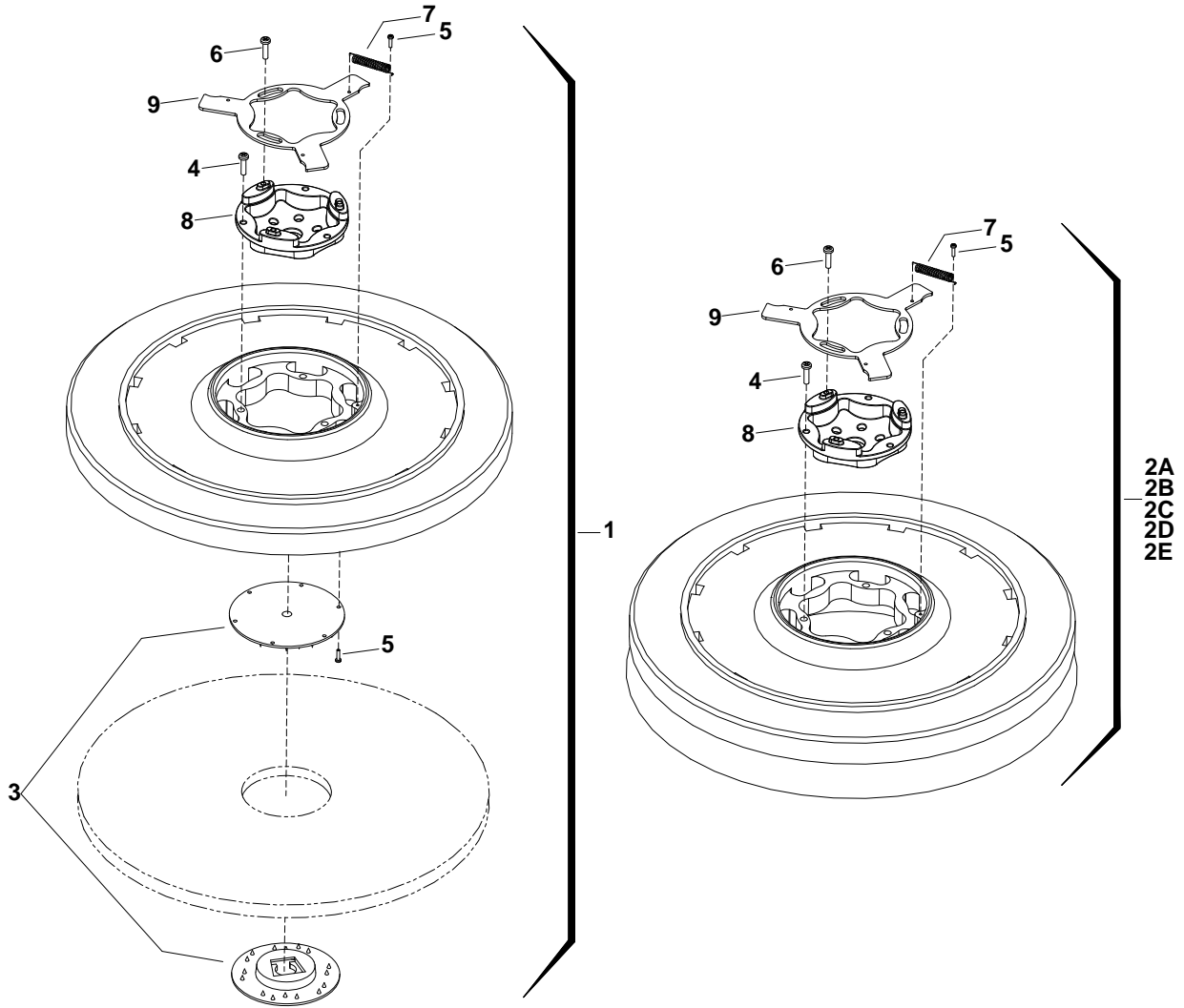

## SCRUB BRUSH/PAD DRIVER

### 26 IN DISK:

REF	PART NO.	PRV NO.	QTY	DESCRIPTION	SERIAL NO. FROM	NOTES:
1	86000210	02406	2	PAD DRIVER, 13" SD		
2A	86000220	02407	2	BRUSH, 13" POLYPROPYLENE SD		
2B	86000230	02408	2	BRUSH, 13" NYLON SD U19981		
2C	86000240	02410	2	BRUSH, 13" MILD GRIT SD U19882		
3	86005070	51284	1	LOCK, PAD CENTER SNAP, TWO STEP		
4	86276590	70695	3	SCR, #12 X 1.0 PPHMS SS		
5	86276580	70694	4	SCR, 8-32 X 3/4 PTHMS SS		
6	86276600	70696	3	SCR, #10 X 3/4 PTHMS SS		
7	86007910	73817	1	SPRING, EX .31 D X 2.0 L X .03 W SS		
8	86007280	730011	1	SOCKET, DRIVE BRUSH		
9	86005940	62852	1	PLATE, BRUSH RELEASE		

### 32 IN DISK:

REF	PART NO.	PRV NO.	QTY	DESCRIPTION	SERIAL NO. FROM	NOTES:
1	86000290	02418	2	PAD DRIVER, 16" SD		
2A	86000300	02419	2	BRUSH, 16" POLYPROPYLENE SD		
2B	86000310	02420	2	BRUSH, 16" NYLON SD		
2C	86000320	02421	2	BRUSH, 16" NYLON POLISH SD		
2D	86000330	02422	2	BRUSH, 16" MILD GRIT SD		
2E	86000340	02423	2	BRUSH, 16" SUPER AGGRESSIVE SD		
3	86005070	51284	1	LOCK, PAD CENTER SNAP, TWO STEP		
4	86276590	70695	3	SCR, #12 X 1.0 PPHMS SS		
5	86276580	70694	4	SCR, 8-32 X 3/4 PTHMS SS		
6	86276600	70696	3	SCR, #10 X 3/4 PTHMS SS		
7	86007910	73817	1	SPRING, EXT .31 D X 2.0 L X .03 W SS		
8	86007280	730011	1	SOCKET, DRIVE BRUSH		
9	86005940	62852	1	PLATE, BRUSH RELEASE		

# SCRUB DECK AQUA-MIZER-26IN SCRUBHEAD

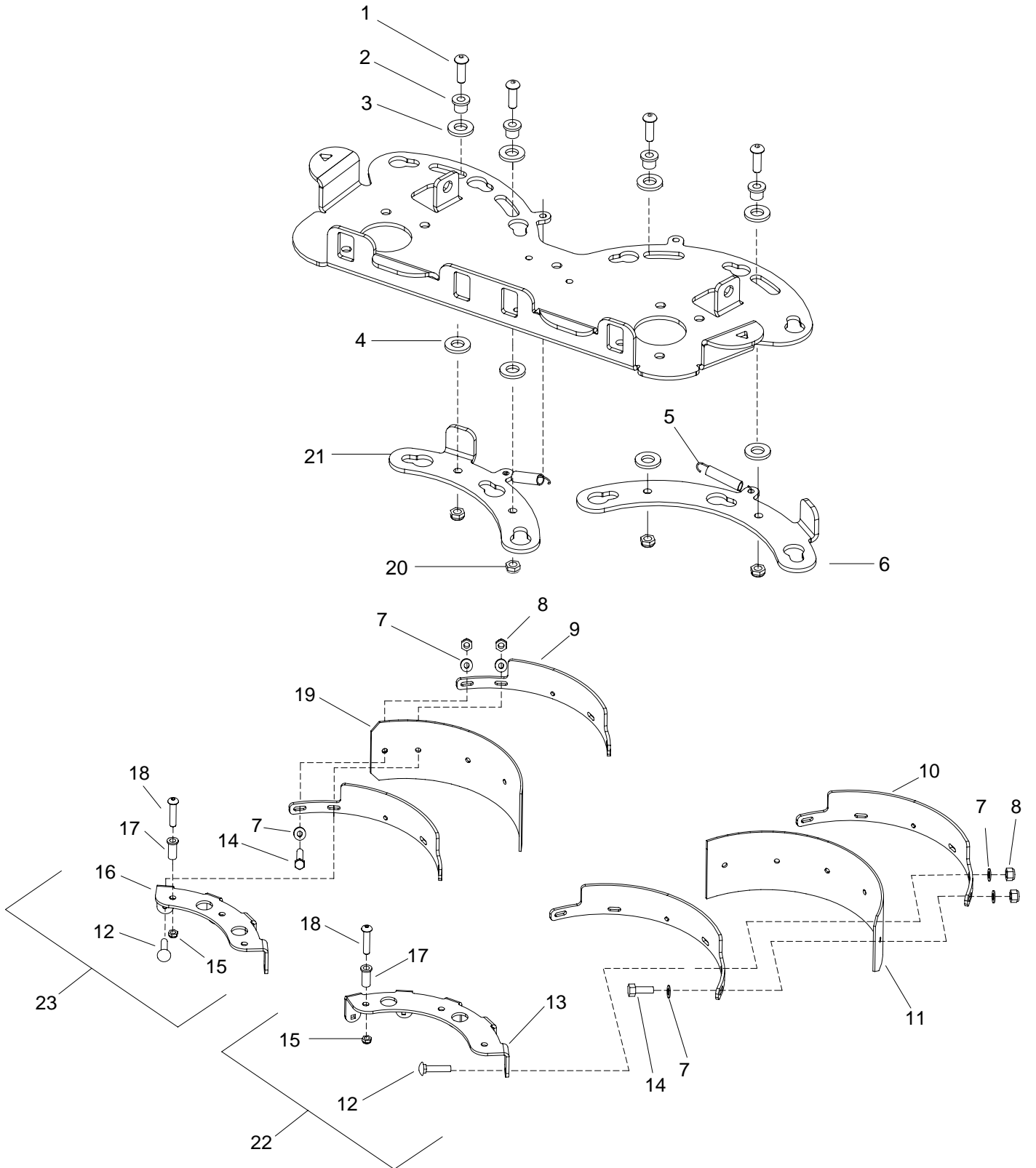

## SCRUB DECK AQUA-MIZER-26IN SCRUBHEAD

REF	PART NO.	PRV NO.	QTY	DESCRIPTION	SERIAL NO. FROM	NOTES:
1	86006930	70514	4	SCR, 5/16-18 X 1.00 BSHCS SS		
2	86228840	09124	4	BEARING, FLANGED .314 ID X .502 OD		
3	86259420	87232	4	WASHER, THRUST .51 ID X 1 OD BRO		
4	86259400	87205	4	WASHER, THRUST .51 ID X 1 OD BRO		
5	86255060	73426	2	SPRING, EXT. .43D X 2.50L X .047W		
6	86082370	62957	1	PLATE, AQ LOCK L 13 IN		
7	86010630	87013	13	WASHER, 1/4 ID C 5/8 OD SS		
8	86271870	57290	11	NUT, 1/4-20 HEX NYLOCK THIN SS		
9	86255990	62939	2	STRAP, AQ, BACK, L 13 IN		
10	86256000	62940	2	STRAP, AQ, BACK, R 13 IN		
11A	86001410	140507	1	BLADE, 13 LEFT		
11B	86135150	730428	1	BLADE, 13 IN LT URETHANE		
12	86276960	70773	9	SCR, 1/4-20 X 1 CARRIAGE SS		
13	86249530	62937	1	PLATE, AQ ATTACH L 13 IN		
14	86273780	70015	2	SCR, 1/4-20 X 3/4 HHCS SS NP		
15	86005630	57022	6	NUT, 3/8-16 HEX NYLOCK THIN SS		
16	86249540	62938	1	PLATE, AQ, ATTACH R 13 IN		
17	86228910	09139	6	BEARING, FLANGED .377 ID C .502 OD		
18	86276860	70747	6	SCR, 3/8-16 X 1.75 BSHCS SS		
19A	86001400	140506	1	BLADE, 13 IN RIGHT		
19B	86135140	730427	1	BLADE, 13IN RT URETHANE		
20	86271840	57285	4	NUT, 5/16-18 HEX NYLOCK THIN SS		
21	86082380	62958	1	PLATE, AQ LOCK R 13 IN		
22	86024970	47397	-	AQUA-MIZER 26" SCRUBHEAD LEFT		SERVICE ASM
23	86024980	47400	-	AQUA-MIZER 26" SCRUBHEAD RIGHT		SERVICE ASM

# SCRUB DECK AQUA-MIZER-32IN SCRUBHEAD

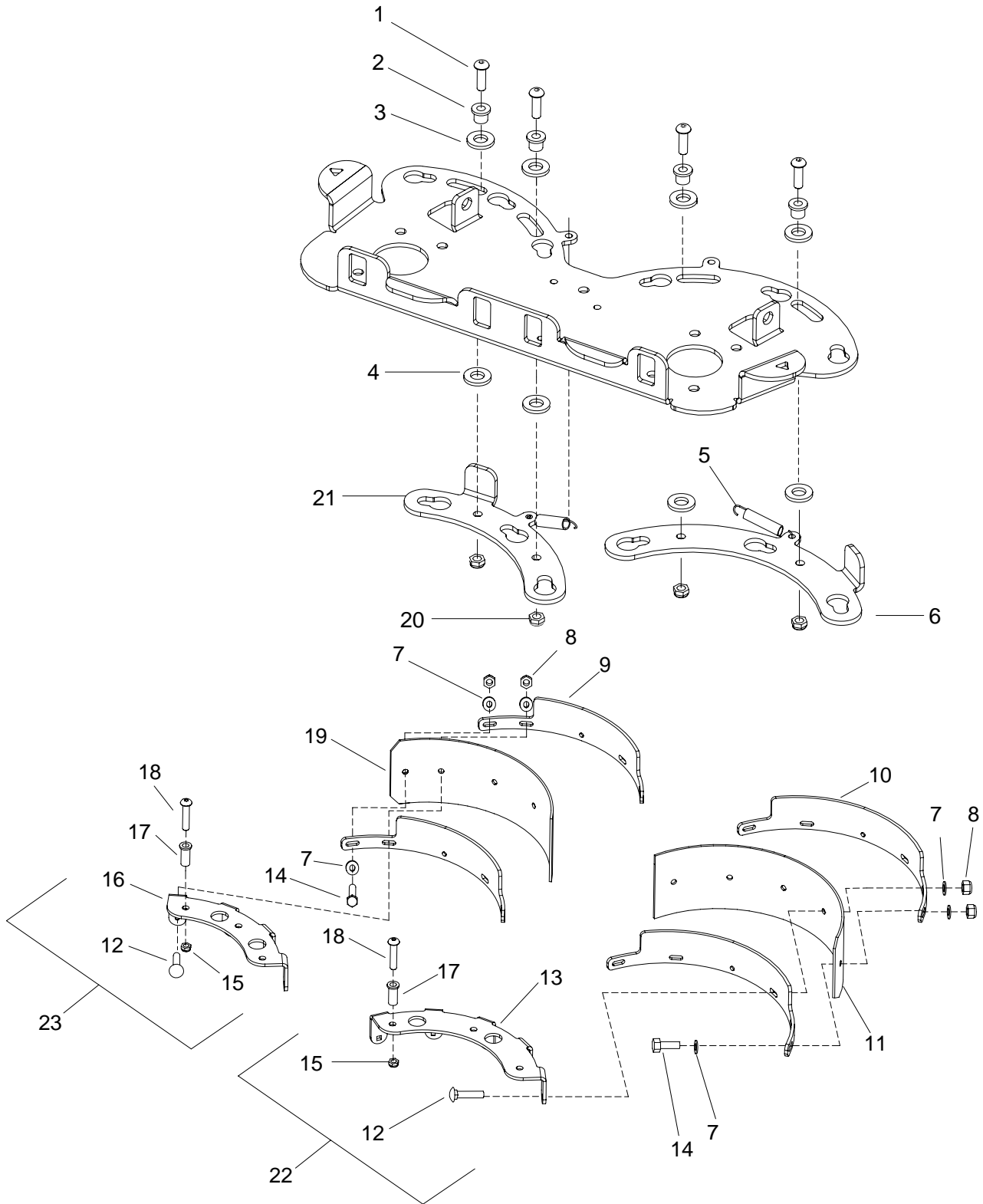

## SCRUB DECK AQUA-MIZER-32IN SCRUBHEAD

REF	PART NO.	PRV. NO	QTY	DESCRIPTION	SERIAL NO. FROM	NOTES:
1	86006930	70514	4	SCR, 5/16-18 X 1.00 BSHCS SS		
2	86228840	09124	4	BEARING, FLANGED .314 ID X .502 OD		
3	86259420	87232	4	WASHER, THRUST .51 ID X 1 OD BRO		
4	86259400	87205	4	WASHER, THRUST .51 ID X 1 OD BRO		
5	86255060	73426	2	SPRING, EXT. .43D X 2.50L X .047W		
6	86249590	66374	1	PLATE, AQ LOCK LEFT 16 IN		
7	86010630	87013	13	WASHER, 1/4 ID 5/8 OD SS		
8	86271870	57290	11	NUT, 1/4-20 HEX NYLOCK THIN SS		
9	86256020	730131	2	STRAP, AQ, BACK, L 16 INCH		
10	86256010	730130	2	STRAP, AQ, BACK, L 16 INCH		
11A	86001430	140528	1	BLADE, AQ LEFT 16 INCH		
11B	86135160	730429	1	BLADE, AQ LT 16 INCH URETHANE		
12	86273810	70018	2	SCR, 1/4-20 X 1 HHCS SS		
13	86082870	66370	1	PLATE, AQ ATTACH L, 16"		
14	86276960	70773	9	SCR, 1/4-20 X 1 CARRIAGE SS		
15	86005630	57022	6	NUT, 3/8-16 HEX NYLOCK THIN SS		
16	86082880	66371	1	PLATE, AQ, ATTACH R 16 IN		
17	86228910	09139	6	BEARING, FLANGED .377 ID C .502 OD		
18	86276860	70747	6	SCR, 3/8-16 X 1.75 BSHCS SS		
19A	86135140	140527	1	BLADE, AQ RIGHT 16 INCH		
19B	86135170	730430	1	BLADE, AQ RT 16 INCH URETHANE		
20	86271840	57285	4	NUT, 5/16-18 HEX NYLOCK THIN SS		
21	86249600	66375	1	PLATE, AQ LOCK RIGHT 16 IN		
22	86024960	47396	-	AQUA-MIZER 32" SCRUBHEAD LEFT		SERVICE ASM
23	86004700	47401	-	AQUA-MIZER 32" SCRUBHEAD RIGHT		SERVICE ASM

# SCRUB DECK MOTORS

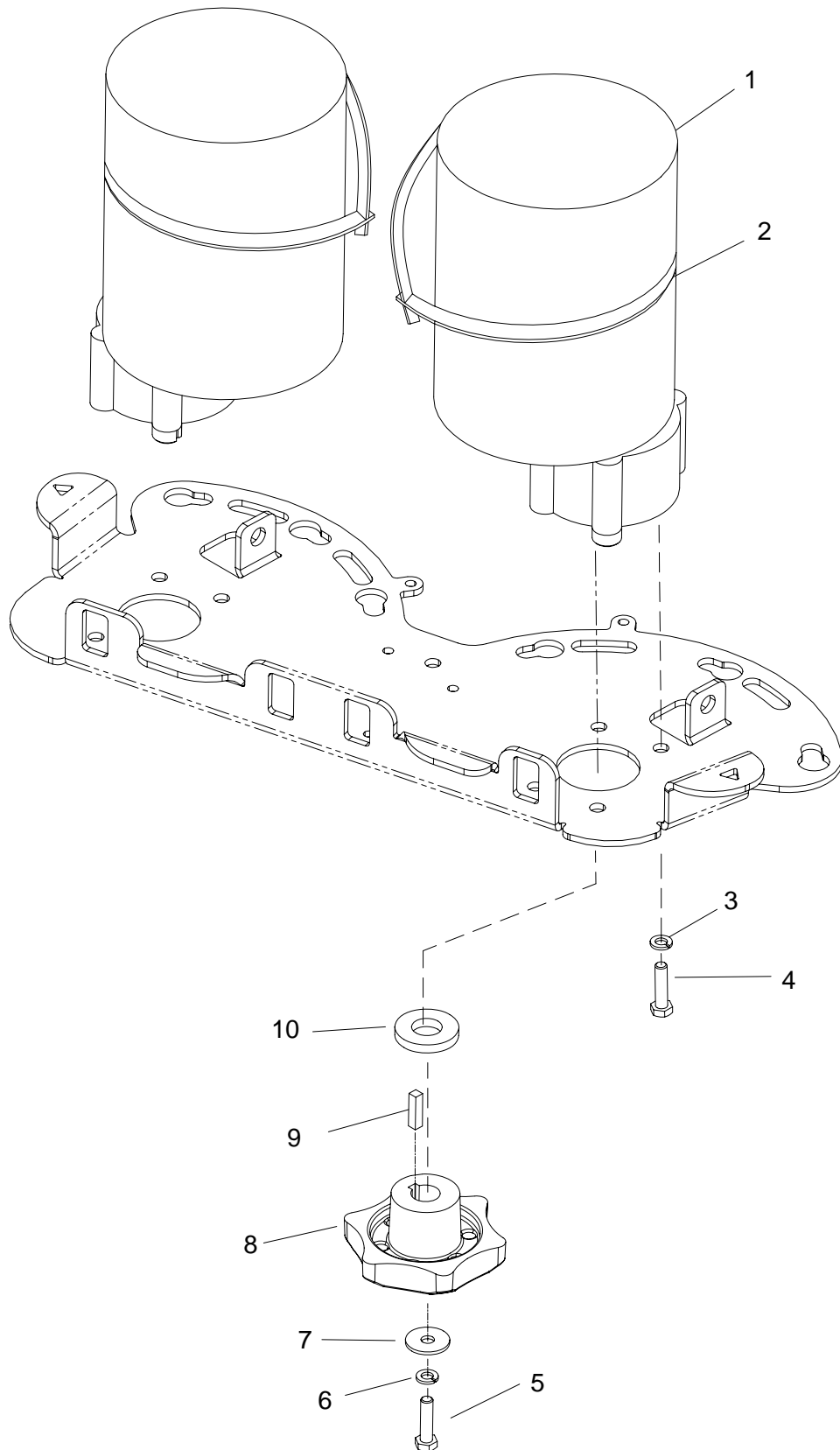

## SCRUB DECK MOTORS

REF	PART NO.	PRV NO.	QTY	DESCRIPTION	SERIAL NO. FROM	NOTES:
1	86005320	53630	2	MOTOR ASM, 24VDC 200RPM GEAR		
1A	86001360	140394	-	BRUSH SET, CCL MOTORS		SERVICE ONLY
2	86002830	27196	2	CABLE TIE, .375 X 24.7		
3	86010790	87163	8	WASHER, 3/8 SPLIT LOCK PLTD		
4	86276970	70774	8	SCR, 3/8-16 X 3/4 HHCS SS		
5	86007020	70673	2	SCR, 5/16-18 X 1.25 HHCS SS		
6	86279130	87083	2	WASHER, 5/16 SPLIT LOCK PLTD		
7	86279630	87212	2	WASHER, .344ID X 1.13OD X .09T PLTD		
8	86003420	29220	2	DRIVER, BRUSH SD		
9	86004810	48040	2	KEY, 1/4 SQ. X 1.00		SUPPLIED W/ MTR
10	86279640	87213	2	WASHER, .78ID X 1.63OD X .25T PLTD		

# SCRUB DECK SKIRT

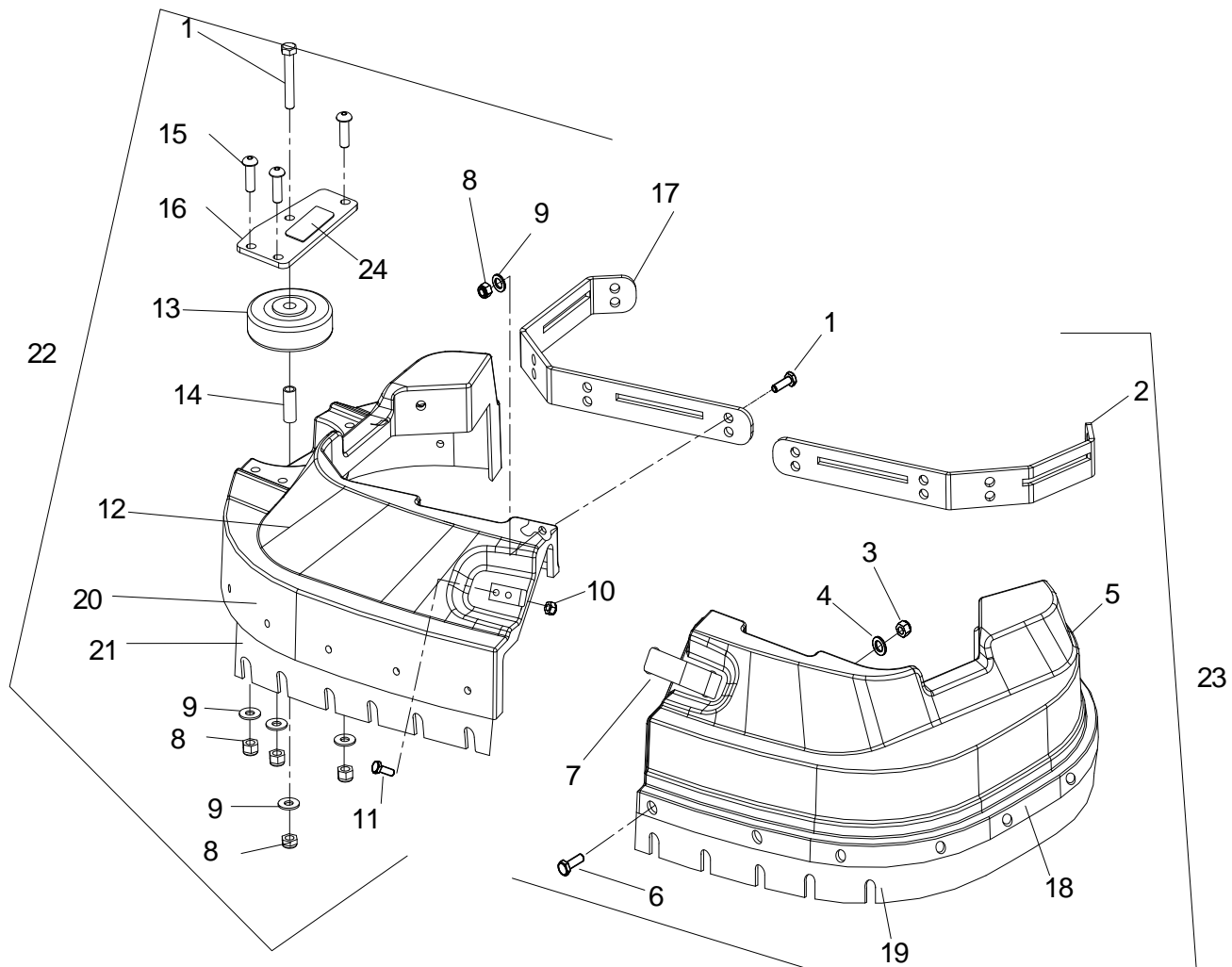

## SCRUB DECK SKIRT-26IN SCRUBHEAD

REF	PART NO.	PRV. NO	QTY	DESCRIPTION	SERIAL NO. FROM	NOTES:
1	86006930	70514	10	SCR, 5/16-18 X 1.00 BSHCS SS		
2	86069650	140488	1	BRACKET, SHROUD LEFT		
3	86271900	57294	19	NUT, 10-24 HEX NYLOCK THIN SS	1000094309	
4	86010650	87018	19	WASHER, #10 X 9/16 ODS		
5	86062940	730113	1	SHROUD, SCRUBDECK 26" LFT		
6	86277110	70789	19	SCR, 10-24 X 3/4 PPHMS SS	1000094309	
7	86161800	46-802531	1	LATCH & CONCEALED KEEPER		
8	86271840	57285	12	NUT, 5/16-18 HEX NYLOCK THIN SS	1000094309	
9	86292500	-	11	WASHER, 5/16 ID X 9/16 OD SS		
10	86270920	57049	4	NUT, 6-32 HEX NYLOCK SS		
11	86273950	70056	4	SCR, 6-32 X 1/2 PPHMS SS	1000094309	
12	86062950	730115	1	SHROUD, SCRUBDECK 26" RIGHT		
13	86011020	89202	1	WHEEL, 3" DIA CUSHION RUBBER		
14	86001350	140390	1	BUSHING, SPANNER, .435 X 1.10		
15	86277150	70797	1	SCR, 5/16-18 X 2 BSHCS SS	1000094309	
16	86082950	66385	1	PLATE, BUMPER WHEEL ATTACH	1000094309	
17	86069640	140487	1	BRKT, SHROUD RIGHT		
18	86066380	140543	1	BAND, SHROUD SKIRT LEFT		
19	86007440	730119	1	SKIRT, 26INCH LEFT		
20	86066390	140544	1	BAND, SHROUD SKIRT RIGHT		
21	86007450	730120	1	SKIRT, 26INCH RIGHT		
22	86004730	47414	-	SHROUD ASM, 26" RIGHT SCRUBHEAD		SERVICE ONLY
23	86004740	47415	-	SHROUD ASM, 26" LEFT SCRUBHEAD		SERVICE ONLY
24	86244100	500831	1	LABEL, AQUA-MIZER		

# SCRUB DECK SKIRT – 32IN SCRUBHEAD

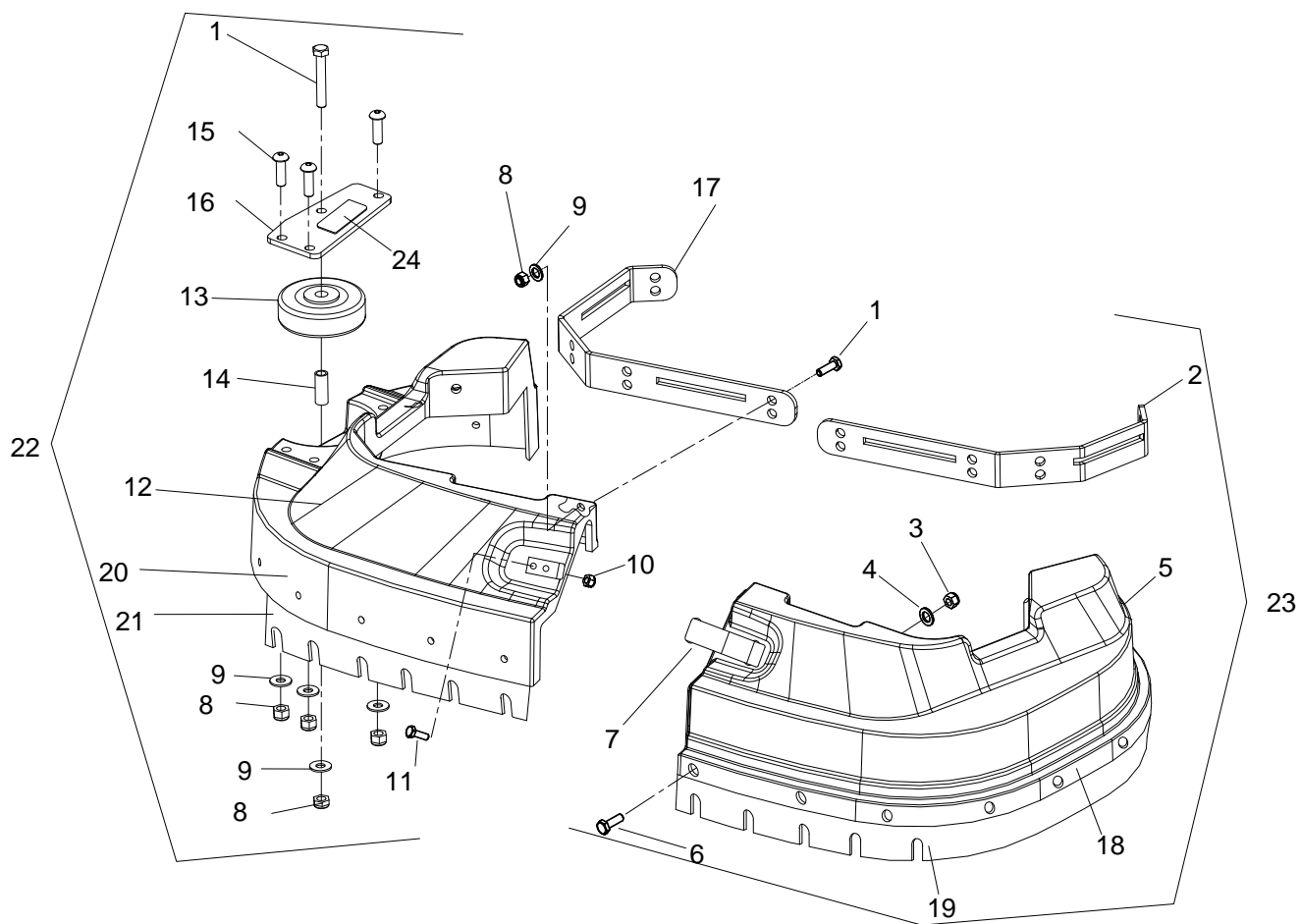

## SCRUB DECK SKIRT-32IN SCRUBHEAD

REF	PART NO.	PRV NO.	QTY	DESCRIPTION	SERIAL NO. FROM	NOTES:
1	86006930	70514	10	SCR, 5/16-18 X 1.00 BSHCS SS		
2	86070050	140563	1	BRACKET, SHROUD RETAINER LEFT		
3	86271900	57294	23	NUT, 10-24 HEX NYLOCK THIN SS	1000094309	
4	86010650	87018	23	WASHER, #10 X 9/16 OD		
5	86062960	730136	1	SHROUD, SCRUBDECK 32" LEFT		
6	86277110	70789	23	SCR, 10-24 X 3/4 PPHMS SS	1000094309	
7	86161800	46-802531	1	LATCH & CONCEALED KEEPER		
8	86271840	57285	10	NUT, 5/16-18 HEX NYLOCK THIN SS	1000094309	
9	86292500	-	11	WASHER, 5/16 ID X 9/16 OD SS		
10	86270920	57049	4	NUT, 6-32 HEX NYLOCK SS		
11	86273950	70056	4	SCR, 6-32 X 1/2 PPHMS SS	1000094309	
12	86062970	730137	1	SHROUD, SCRUBDECK 32" RIGHT		
13	86011020	89202	1	WHEEL, 3" DIA CUSHION RUBBER		
14	86001350	140390	1	BUSHING, SPANNER, .435 X 1.10		
15	86277150	70797	1	SCR, 5/16-18 X 2 BSHCS SS	1000094309	
16	86082950	66385	1	PLATE, BUMPER WHEEL ATTACH	1000094309	
17	86070040	140562	1	BRKT, SHROUD RETAINER RIGHT		
18	86066410	140549	1	BAND, SKIRT LEFT 32 INCH		
19	86007530	730145	1	SKIRT, 32 INCH LEFT		
20	86069640	140548	1	BAND, SKIRT RIGHT 32 INCH		
21	86007540	730146	1	SKIRT, 32 INCH RIGHT		
22	86004710	47412	-	SHROUD ASM, 32" RIGHT SCRUBHEAD		SERVICE ONLY
23	86004720	47413	-	SHROUD ASM, 32" LEFT SCRUBHEAD		SERVICE ONLY
24	86244100	500831	1	LABEL, AQUA-MIZER		

# SCRUB DECK LIFT LINKAGE-26IN SCRUBDECK

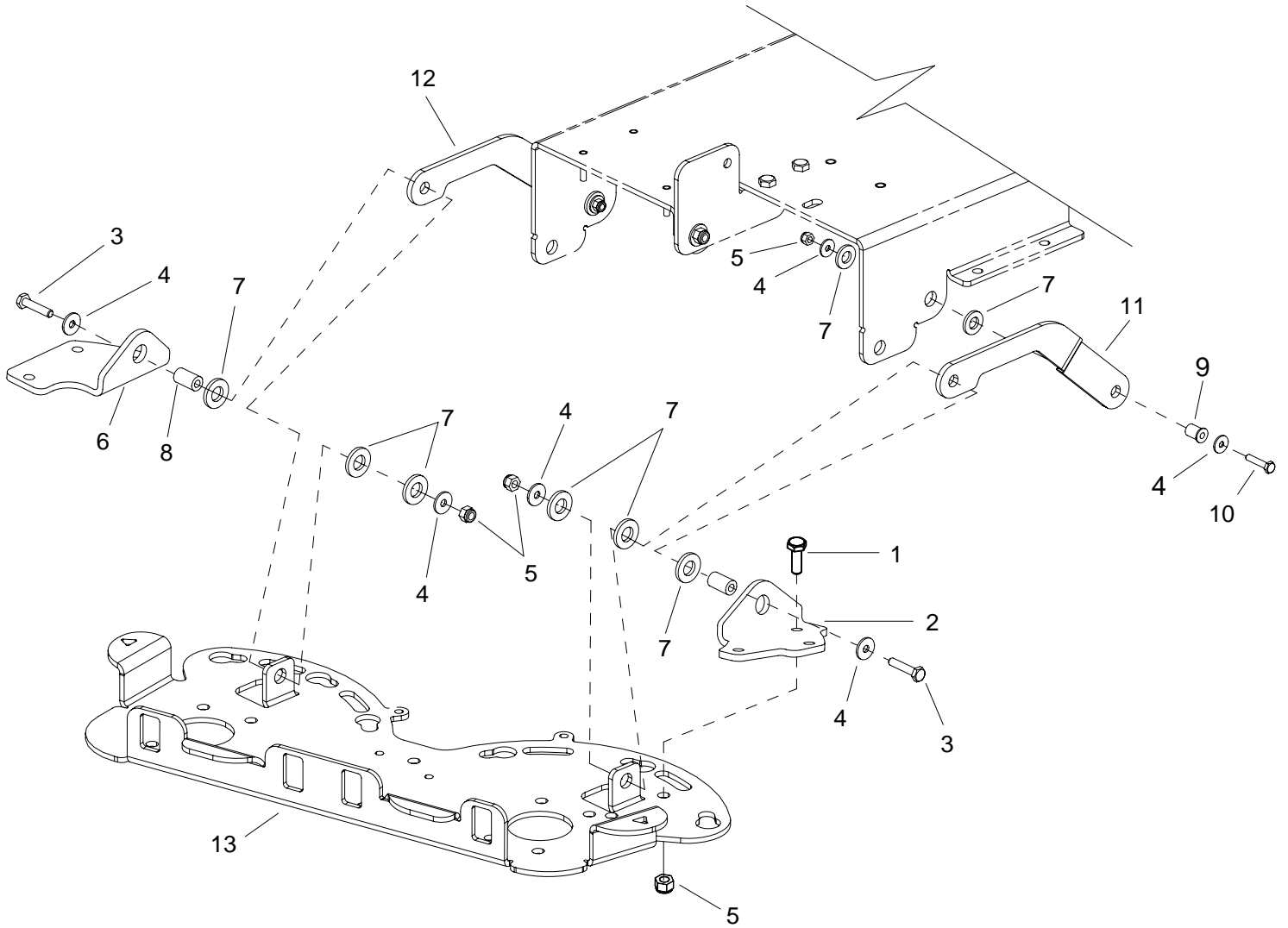

## **SCRUB DECK LIFT LINKAGE-26IN SCRUBDECK**

REF	PART NO.	PRV. NO	QTY	DESCRIPTION	SERIAL NO. FROM	NOTES:
1	86273780	70015	6	SCR, 1/4-20 X 3/4 HHCS SS NP		
2	86069910	140545	1	BRACKET, ANGLE SUPPORT LEFT		
3	86273740	70010	2	SCR, 1/4-20 X 1.5 HHCS SS		
4	86010630	87013	8	WASHER, 1/4ID X 5/8OD SS		
5	86271870	57290	10	NUT, 1/4-20 HEX NYLOCK THIN SS		
6	86069920	140546	1	BRACKET, ANGLE SUPPORT RIGHT		
7	86259400	87205	10	WASHER, THRUST .51ID X 1OD BRO		
8	86228920	09140	2	BEARING, .252ID X .503OD X 1.0		
9	86228900	09138	2	BEARING, FLANGED, .252ID X .503OD		
10	86273820	70019	2	SCR, 1/4-20 X 1.25 HHCS SS		
11	86066770	140492	1	BAR LINK LEFT		
12	86066720	140447	1	BAR LINK, RIGHT		
13	86236650	34388	1	FRAME, W24V SCRUB DECK		

# SCRUB DECK LIFT LINKAGE-32IN SCRUBDECK

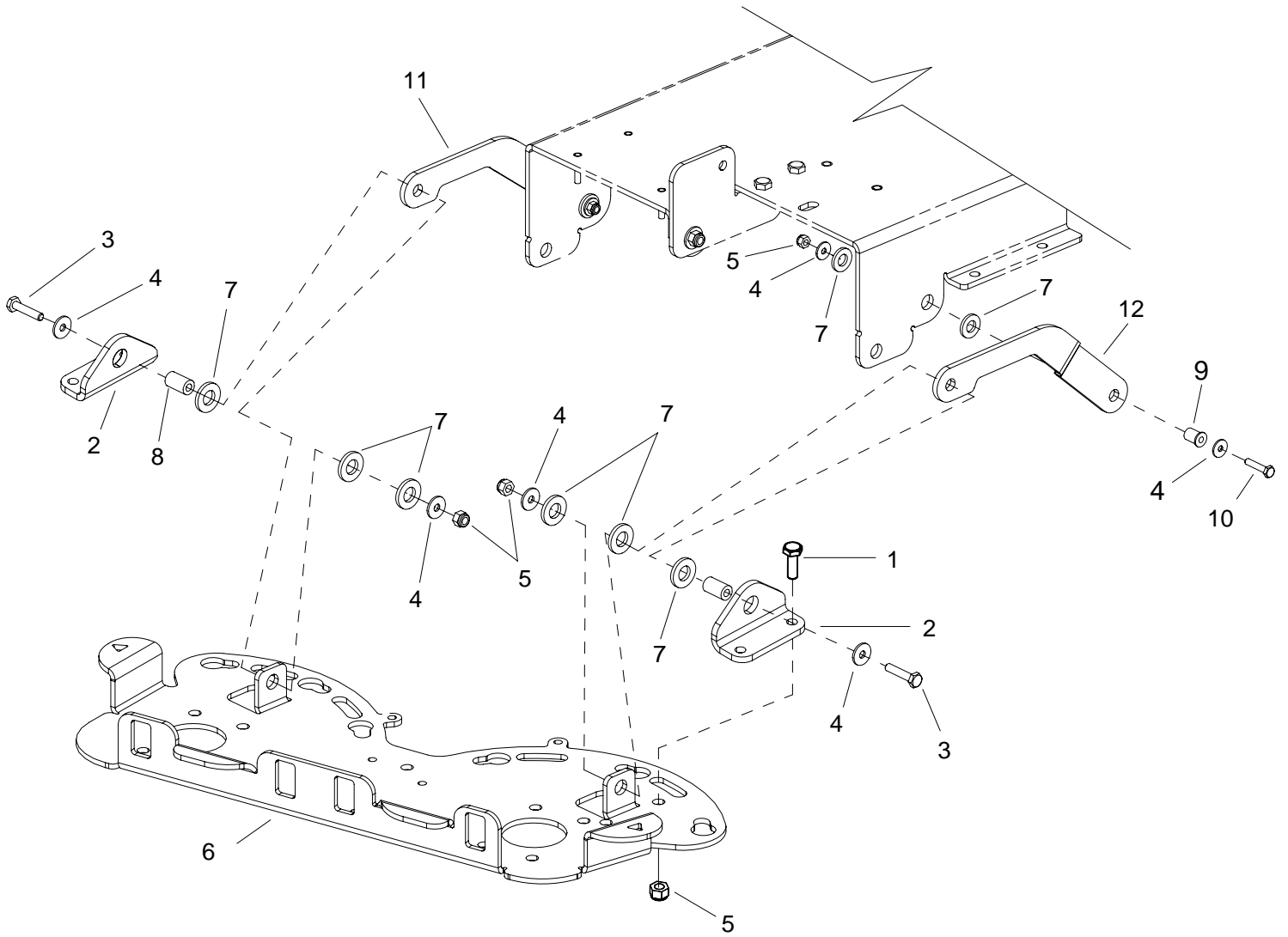

## **SCRUB DECK LIFT LINKAGE-32IN SCRUBDECK**

REF	PART NO.	PRV NO.	QTY	DESCRIPTION	SERIAL NO. FROM	NOTES:
1	86273780	70015	4	SCR, 1/4-20 X 3/4 HHCS SS NP		
2	86070030	140561	2	BRACKET, ANGLE SUPPORT		
3	86273740	70010	2	SCR, 1/4-20 X 1.5 HHCS SS		
4	86010630	87013	8	WASHER, 1/4ID X 5/8OD SS		
5	86271870	57290	8	NUT, 1/4-20 HEX NYLOCK THIN SS		
6	86236670	34393	1	FRAME 36V, SCRUB DECK		
7	86259400	87205	10	WASHER, THRUST .51ID X 1OD BRO		
8	86228920	09140	2	BEARING, .252ID X .503OD X 1.0		
9	86228900	09138	2	BEARING FLANGED, .252ID X .503OD		
10	86273820	70019	2	SCR, 1/4-20 X 1.25 HHCS SS		
11	86066810	140513	1	BAR, LINKAGE, LEFT		
12	86066870	140566	1	BAR LINK, RIGHT		

# SCRUB DECK LIFT

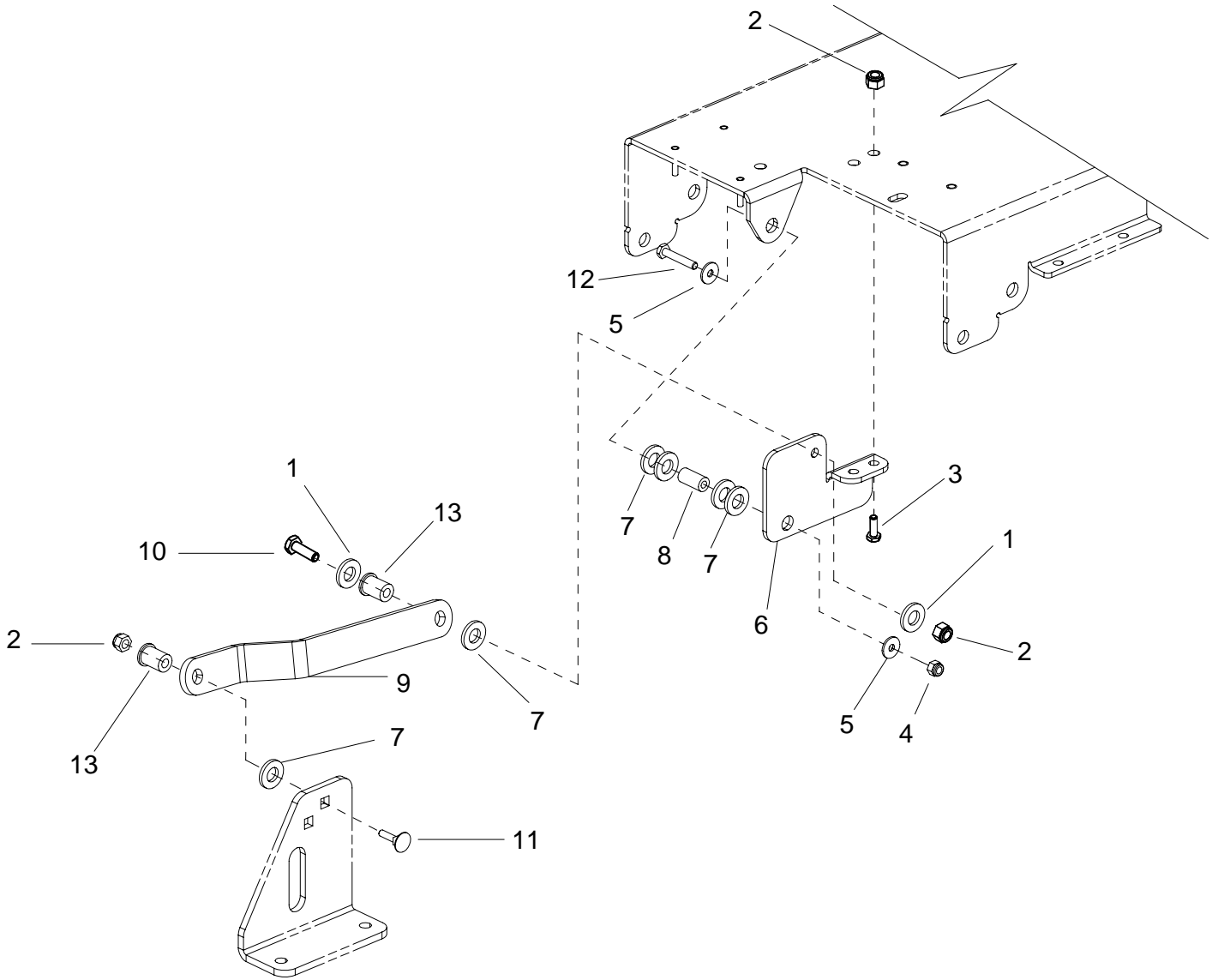

**SCRUB DECK LIFT**

REF	PART NO.	PRV. NO	QTY	DESCRIPTION	SERIAL NO. FROM	NOTES:
1	86010670	87029	2	WASHER, 5/16 FLAT SS		
2	86271840	57285	4	NUT, 5/16-18 HEX NYLOCK THIN SS		
3	86276780	70728	2	SCR, 5/16-18 X 3/4 HHCS SS		
4	86271870	57290	3	NUT, 1/4-20 HEX NYLOCK THIN SS		
5	86010630	87013	6	WASHER, 1/4ID X 5/8OD SS		
6	86069750	140508	1	BRACKET, FRAME MOUNT		
7	86259400	87205	10	WASHER, THRUST .51ID X 1OD BRO		
8	86228920	09140	1	BEARING, .252ID X .503OD X 1.0		
9	86069760	140509	1	BRACKET, CENTER LINK		
10	86007020	70673	1	SCR, 5/16-18 X 1.25 HHCS SS		
11	86197150	70669	1	SCR, 5/16 X 1.25 ELEV FLDG SA		
12	86273740	70010	1	SCR, 1/4-20 X 1.5 HHCS SS		
13	86228840	09124	2	BEARING, FLANGED .314ID X .502OD		

# SCRUB DECK LIFT

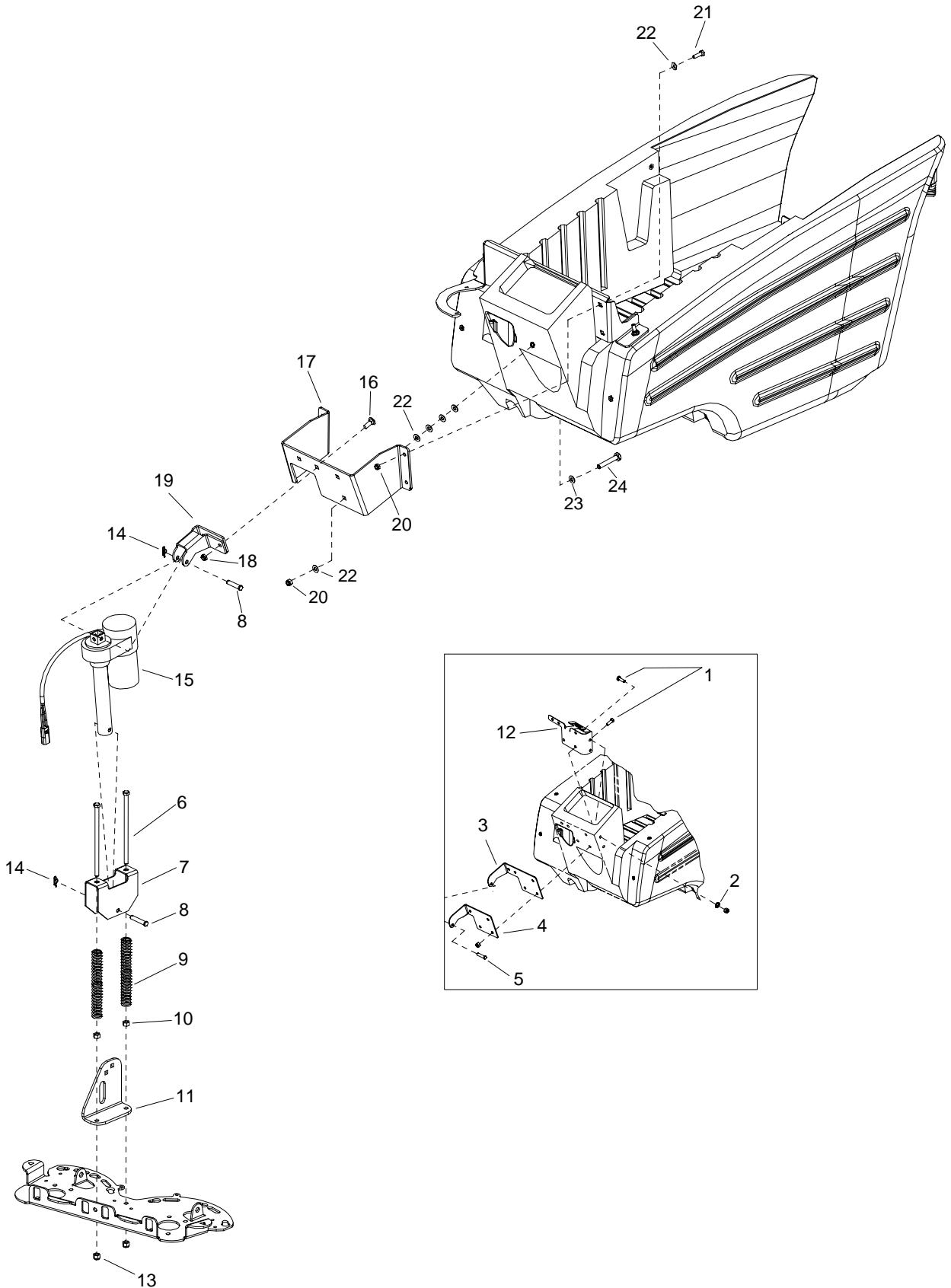

## SCRUB DECK LIFT

REF	PART NO.	PRV NO.	QTY	DESCRIPTION	SERIAL NO. FROM	NOTES:
1	86276920	70755	7	SCR, 3/8-16 X 1HHCS SS NP		
2	86279590	87185	2	WASHER, 3/8 SEALING X 3/4 OD		WAS 87003
3	86069590	140479	1	BRACKET, ACTUATOR MOUNT BACK		
4	86069600	140480	1	BRACKET, ACTUATOR MOUNT FRONT		
5	86272410	66233	1	PIN, CLEVIS 3/8" X 1.63" PLTD		
6	86277010	70778	2	SCR, 3/8-16 X 7 HHCS SS		
7	86068130	140456	1	BRACKET, ACTUATOR TUBE		
8	86248970	81406	1	PIN, CLEVIS 3/8 X 2 PLTD		
9	86254910	730134	2	SPRING, COMP .89OD X 6.13L		
10	86005730	57111	2	NUT, 3/8-16 HEX		
11	86069770	140510	1	BRACKET, DECK MOUNT		
12	86069930	140547	1	BRKT, SOLUTION FILL		
13	86005630	57022	7	NUT, 3/8-16 HEX NYLOCK THIN SS		
14	86008670	80606	2	COTTER, 3/8" RING		
15	86011960	-	1	ACTUATOR, 24VDC 5.0 STRK		
16	86277280	70822	2	SCR, 3/8-16 X 1.00 CARRIAGE SS	*	
17	86068160	140707	1	BRACKET, TANK BRACE	*	
18	86005630	57022	2	NUT, 3/8-16 HEX NYLOCK THIN SS	*	
19	86068170	140708	1	BRACKET, ACTUATOR MOUNT	*	
20	86271840	57285	5	5/16-18 HEX NYLOCK THIN SS	*	
21	86006560	70083	4	SCR, 5/16-18 X 1 HHCS SS NP	*	
22	86010670	87029	9	WASHER, 5/16 FLAT SS	*	
23	86279650	87222	1	WASHER, SEAL 5/16 X 3/4 OD SS	1000141108	
24	86274720	70264	1	SCR, 5/16-18 X 1.50 HHCS SS	1000141108	

# SOLUTION

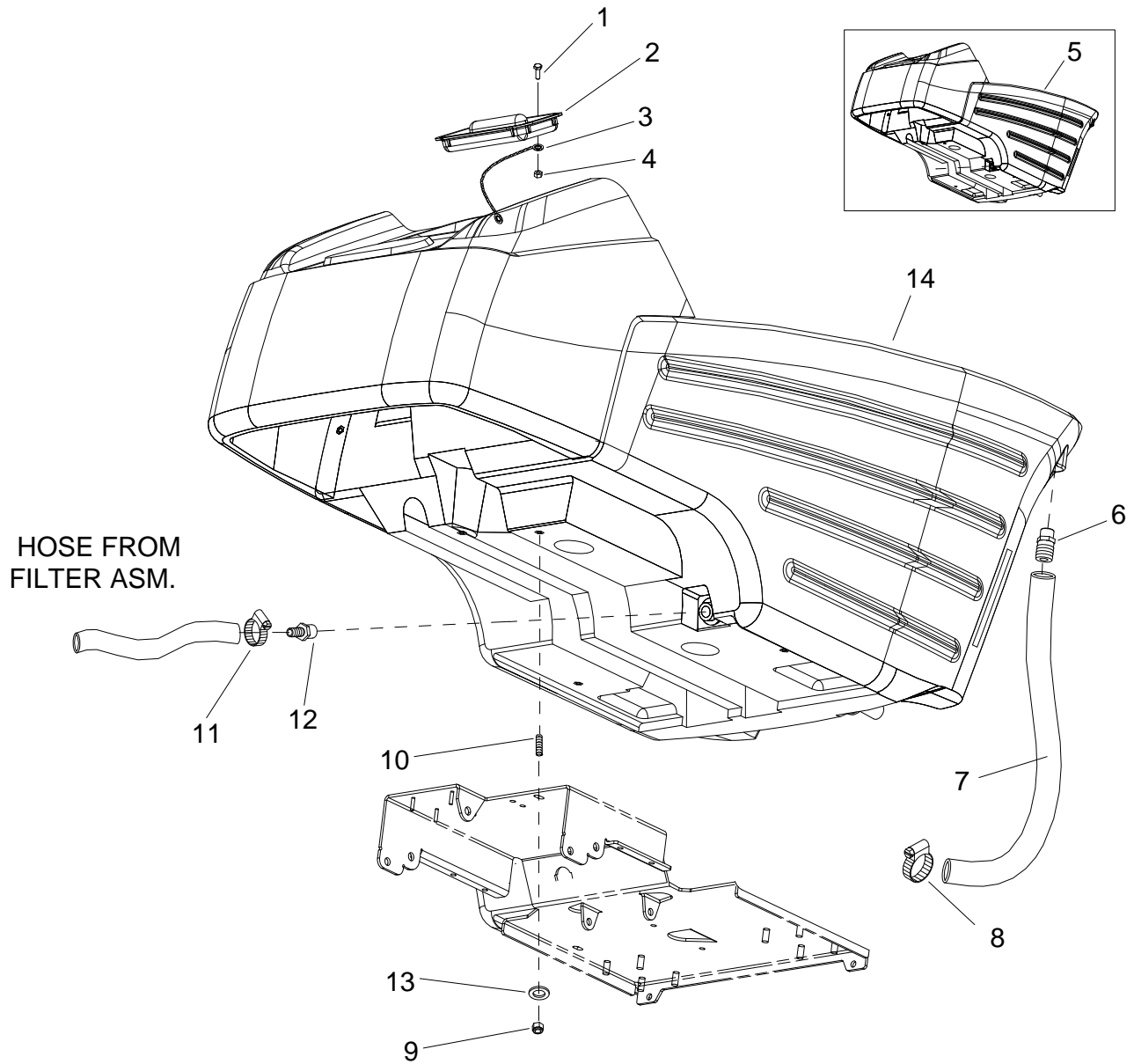

**SOLUTION**

REF	PART NO.	PRV. NO	QTY	DESCRIPTION	SERIAL NO. FROM	NOTES:
1	86273950	70056	1	SCR, 6-32 X 1/2 PPHMS SS		
2	86234790	27827	1	COVER CLP SOLUTION		
3	86246080	51368	1	LANYARD, 18.0 W/ LOOP & EYE		
4	86014810	-	1	NUT, 6-32 ACORN SS		
5	86008270	75370	1	TANK, SOLUTION 24V, BLU		
6	86240460	40089	1	HOSEBARB, 1/2 MPT X 1.0 HOSE		
7	86282050	39562	1	HOSE, 1.0ID 1/8W X .12W CLR X 24.5"		
8	86233110	20018	1	CLAMP, 1.0" WORM GEAR		
9	86271840	57285	4	NUT, 5/16-18 HEX NYLOCK THIN SS		
10	86276380	70639	4	SCR, 5/16-18 X 1.25 SSSCU		
11	86233150	20042	1	CLAMP, 3/8 HOSE (D-SLOT)		
12	86197910	40022	1	HOSEBARB, 1/2 MPT X 1/2 POLY DL		
13	86010670	87029	4	WASHER, 5/19 FLAT SS		
14	86032890	75460	1	TANK, SOLUTION 24V	1000141108	SCEX264/SCEX324

# SOLUTION

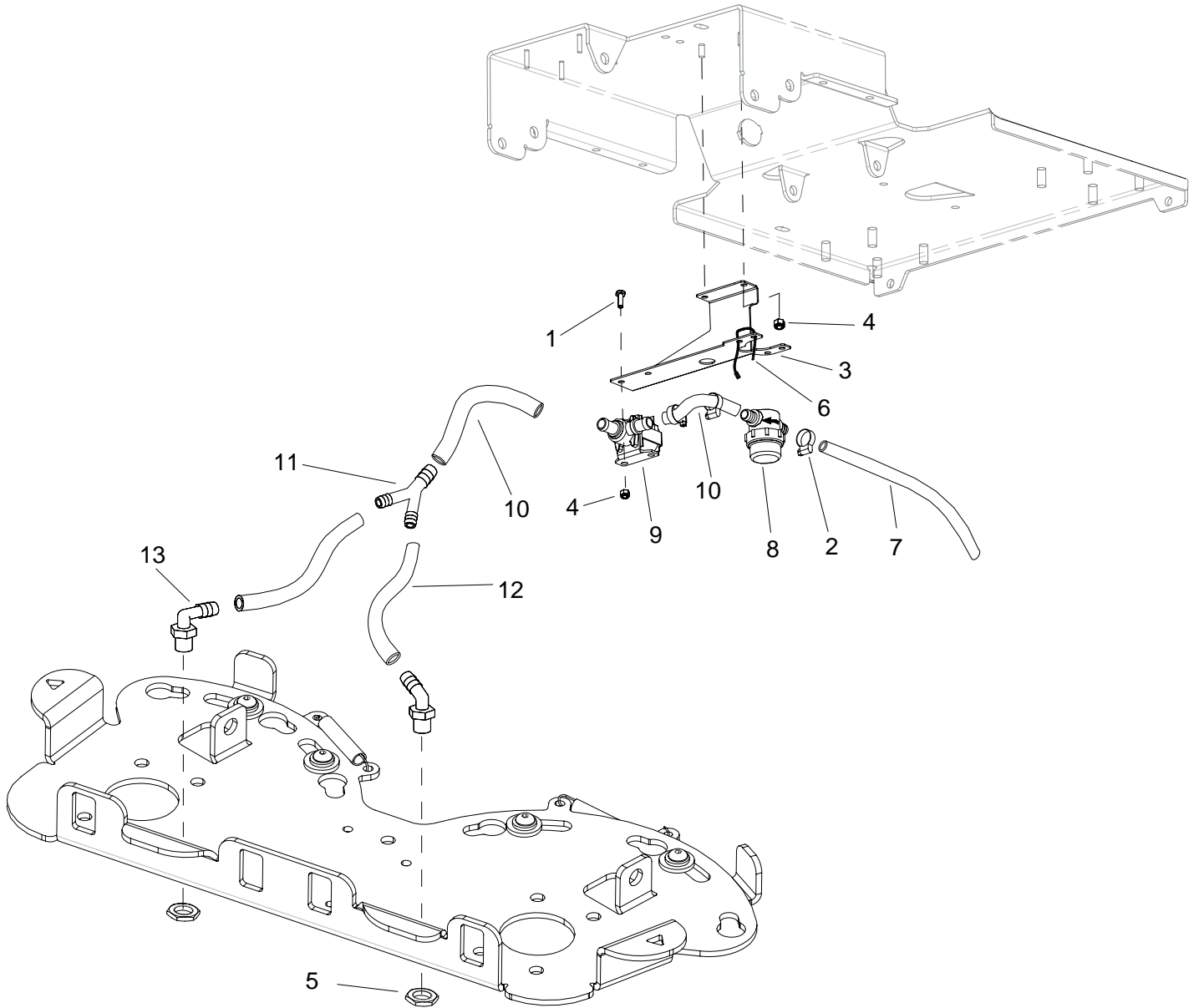

**SOLUTION**

REF	PART NO.	PRV NO.	QTY	DESCRIPTION	SERIAL NO. FROM	NOTES:
1	86273750	70011	2	SCR, 1/4-20 X 5/8 HHCS SS NP		
2	86233150	20042	3	CLAMP, 3/8 HOSE (D-SLOT)		
3	86069790	140518	1	BRACKET, FILTER/SOLUTION MOUNT		
4	86271870	57290	4	NUT, 1/4-20 HEX NYLOCK THIN SS		
5	86271830	57283	2	NUT, 3/8 NPT PLASTIC		
6	86264940	27051	4	CABLE TIE, 11.38" UL/CSA		
7	86282190	39616	1	HOSE, 1/2" WIRE BOUND X 13"		
8	86007560	730161	1	STRAINER, 1/2 HOSE 20 MESH		
-	86005870	59021	1	O-RING, FILTER SEAL RON-VIK		
-	86007750	73405	1	SCREEN, 20 MESH STRAINER		
-	86313160	-	-	CAP, STRAINER SHORT		
9	86010540	84141	1	VALVE, 24VDC SOL 1/2" HOSEBARB		
-	86003460	29260	-	DIAPHRAGM SRVC PART SLND		SERVICE ONLY
-	86136820	47395	-	SOLENOID SPRING KIT		SERVICE ONLY
10	86281100	39274	2	HOSE, 1/2 WIRE BOUND X 7"		
11	86003580	34327	1	FITTING, 1/2" X 3/8" x 3/8" RED T		
12	86280820	39035	2	HOSE, 3/8 NYLOBRD X 10"		
13	86001550	40043	2	HOSEBARB, 3/8 MPT X 3/8 90 D		

# SQUEEGEE-26IN SCRUBHEAD

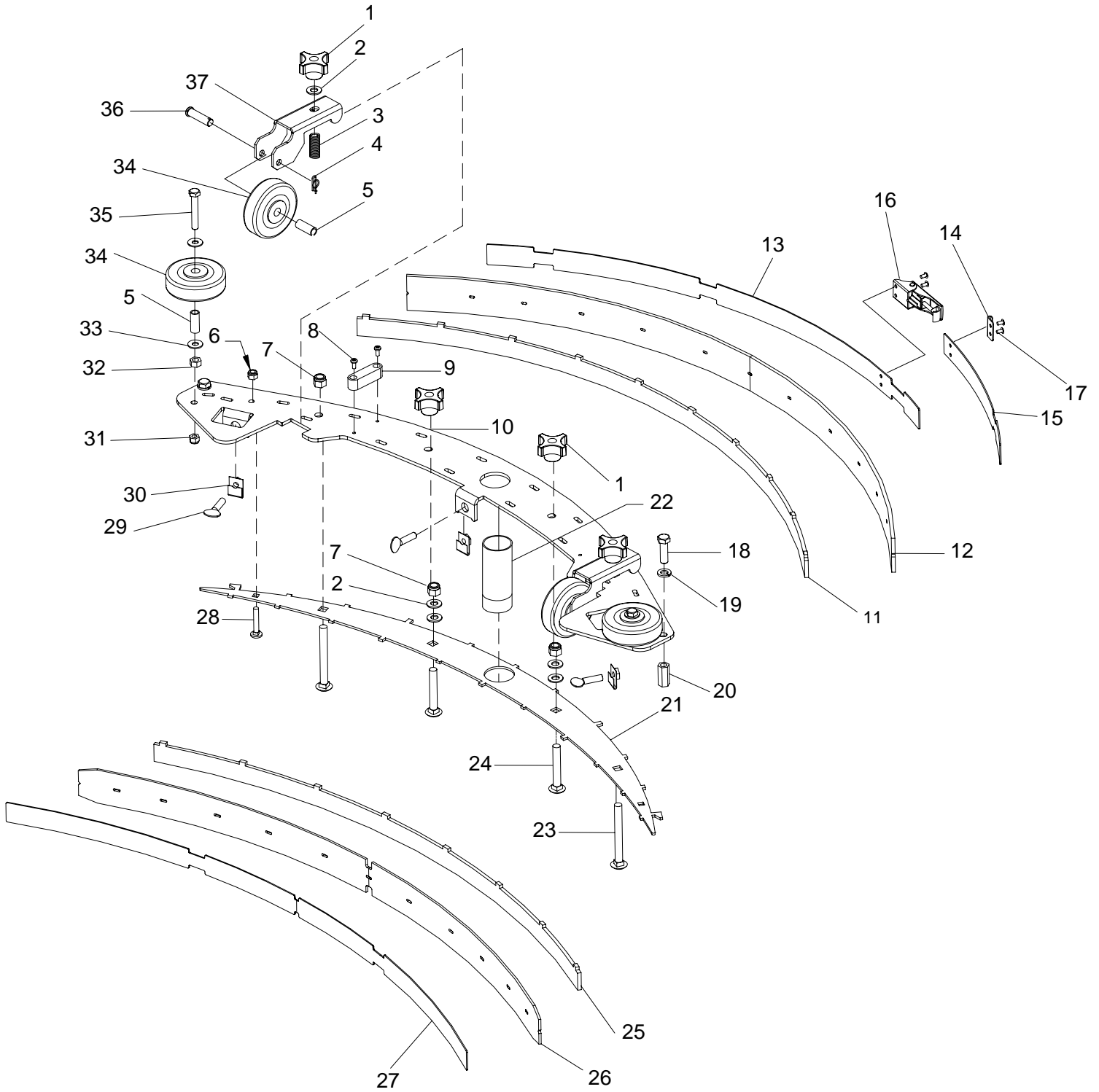

## SQUEEGEE-26IN SCRUBHEAD

REF	PART NO.	PRV NO.	QTY	DESCRIPTION	SERIAL NO. FROM	NOTES:
1	86009200	81535	4	KNOB, 3/8-16 4 PRONG ALUM		
2	86010680	87030	4	WASHER, 3/8ID X 3/4OD NYLON		
3	86007780	73576	2	SPRING, COMP .60D X 2.0L X .045W		
4	86008660	80605	2	COTTER, 5/16 RING		
5	86001350	140390	4	BUSHING, SPANNER .435 X 1.10		
6	86271870	57290	2	NUT, 1/4-20 HEX NYLOCK THIN SS		
7	86005630	57022	4	NUT, 3/8-16 HEX NYLOCK THIN SS		
8	86274130	70098	2	SCR, 8-32 X 3/8 PHTC 'F' PLTD		
9	86009910	82576	1	VIAL, LEVEL		
10	86082420	62970	1	PLATE, SQUEEGEE TOP 35"		
11	86082440	62972	1	PLATE, REAR SQUEEGEE 35"		
12A	86007430	730114	1	SQUEEGEE, REAR BLADE LINATEX		
12B	86137020	730423	1	SQUEEGEE, REAR BLADE URETHANE		
13	86001340	140384	1	BAND, REAR SQUEEGEE		
14	86009180	81489	1	STRIKER, SQUEEGEE STRAP REAR		
15	86001330	140382	1	BAND, REAR SQUEEGEE		
16	86009170	81488	1	LATCH, SQUEEGEE STRAP		
17	86006400	67380	4	RIVET, 5/32OD X 1/8 GRIP		
18	86276920	70755	2	SCR, 3/8-16 X 1 HHCS SS NP		
19	86010790	87163	2	WASHER, 3/8 SPLIT LOCK PLTD		
20	86005840	57269	2	NUT, 3/8-16 HEX COUPLING SS		
21	86082450	62973	1	PLATE, SQUEEGEE BOTTOM 35"		
22	86008390	78493	1	TUBE ASM, SQUEEGEE VAC		
23	86276990	70776	2	SCR, 3/8-16 X 3.5 CARRIAGE SS		
24	86276870	70748	2	SCR, 3/8-16 X 2.5 CARRIAGE SS		
25	86082430	62971	1	PLATE, SQUEEGEE FRONT 35"		
26A	86008020	73894	1	BLADE, SQUEEGEE FRONT LINATEX 35"		
26B	86137030	730424	1	SQUEEGEE, FRONT BLADE URETHANE		
27	86066370	140383	1	BAND, SQUEEGEE FRONT		
28	86277000	70777	2	SCR, 1/4-20 X 1.5 CARRIAGE SS		
29	86007040	70680	3	SCR, 5/16-18 X 1 THUMB SS TYPE P		
30	86271820	57270	3	NUT, 5/16-18 CAPTIVE "J" PLTD		
31	86271840	57285	2	NUT, 5/16-18 HEX NYLOCK THIN SS		
32	86005650	57031	2	NUT, 5/16-18 HEX		
33	86010670	87029	4	WASHER, 5/16 SS		
34	86011020	89202	4	WHEEL, 3" DIA. CUSHION RUBBER		
35	86276980	70775	2	SCR, 5/16-18 X 2.00 HHCS SS		
36	86006270	66276	2	PIN, CLEVIS 5/16 X 1.63 PLTD		
37	86069870	140531	2	BRACKET, SQUEEGEE WHEEL		
38	86026530	47398	-	SQUEEGEE ASM 26 IN SCRUBHEAD		SERVICE ASM

# SQUEEGEE-32IN SCRUBHEAD

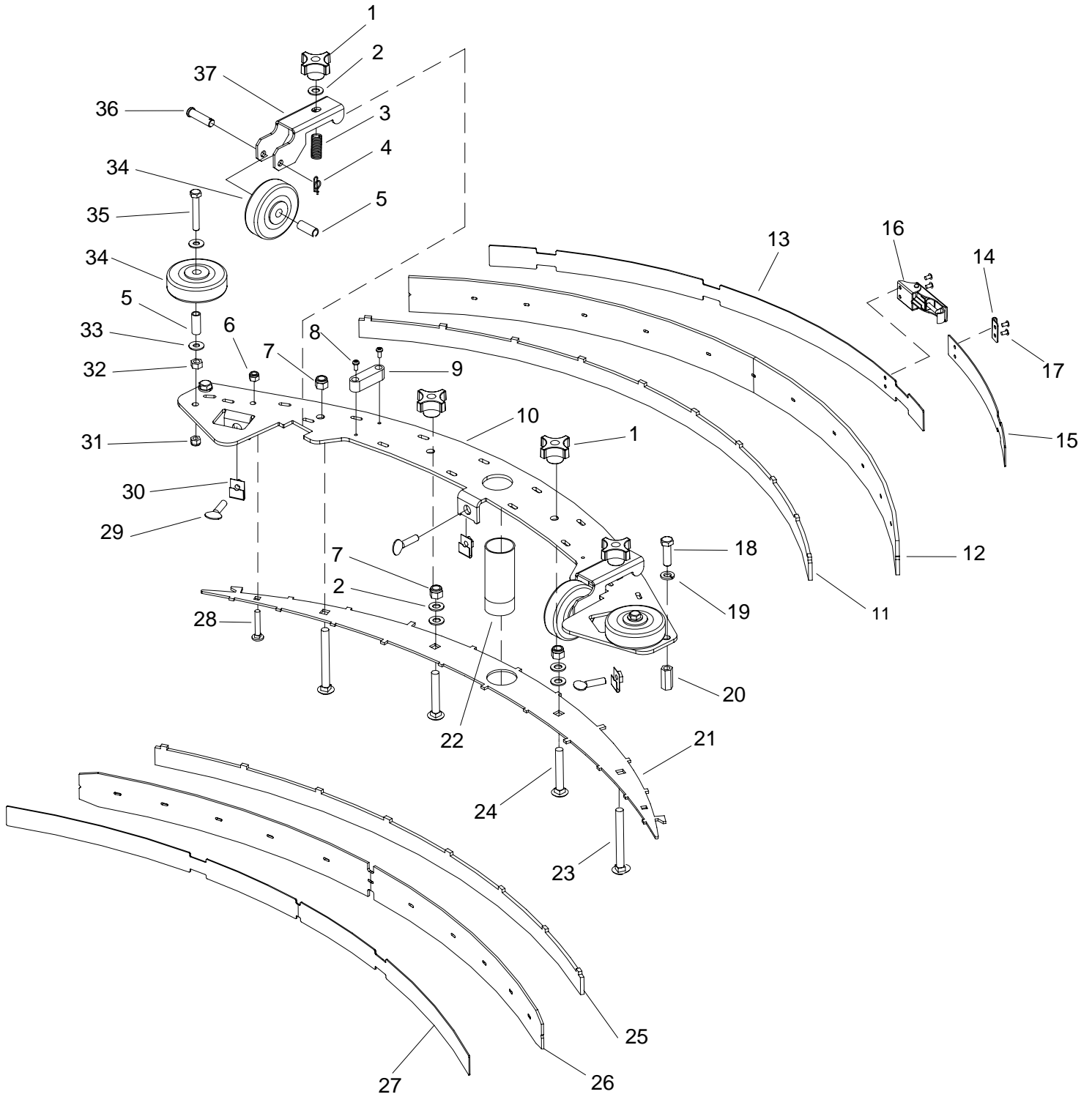

## SQUEEGEE-32IN SCRUBHEAD

REF	PART NO.	PRV NO.	QTY	DESCRIPTION	SERIAL NO. FROM	NOTES:
1	86009200	81535	4	KNOB, 3/8-16 4 PRONG ALUM		
2	86010680	87030	6	WASHER, 3/8ID X 3/4OD NYLON		
3	86007780	73576	2	SPRING, COMP .60D X 2.0L X .045W		
4	86008660	80605	2	COTTER, 5/16" RING		
5	86001350	140390	4	BUSHING, SPANNER .435 X 1.10		
6	86271870	57290	2	NUT, 1/4-20 HEX NYLOCK THIN SS		
7	86005630	57022	4	NUT, 3/8-16 HEX NYLOCK THIN SS		
8	86274130	70098	2	SCR, 8-32 X 3/8 PHTC 'F' PLTD		
9	86009910	82576	1	VIAL, LEVEL		
10	86082460	62974	1	PLATE, SQUEEGEE TOP 40"		
11	86082480	62976	1	PLATE, SQG REAR 40"		
12A	86007490	730133	1	SQUEEGEE, REAR BLADE LINATEX		
12B	86137040	730425	1	SQUEEGEE, REAR BLADE URETHANE		
13	86066360	140381	1	BAND, REAR SQUEEGEE		
14	86009180	81489	1	STRIKER, SQUEEGEE STRAP REAR		
15	86001330	140382	1	BAND, REAR SQUEEGEE		
16	86009170	81488	1	LATCH, SQUEEGEE STRAP		
17	86006400	67380	4	RIVET, 5/32OD X 1/8 GRIP		
18	86276920	70755	2	SCR, 3/8-16 X 1 HHCS SS NP		
19	86010790	87163	2	WASHER, 3/8 SPLIT LOCK PLTD		
20	86005840	57269	2	NUT, 3/8-16 HEX COUPLING SS		
21	86082490	62977	1	PLATE, SQUEEGEE BOTTOM 40"		
22	86008390	78493	1	TUBE ASM, SQUEEGEE VAC		
23	86276990	70776	2	SCR, 3/8-16 X 3.5 CARRIAGE SS		
24	86276870	70748	2	SCR, 3/8-16 X 2.5 CARRIAGE SS		
25	86082470	62975	1	PLATE, SQUEEGEE FRONT 40" SPACER		
26A	86009830	82528	1	BLADE, SQUEEGEE FRONT LINATEX		
26B	86137050	730426	1	SQUEEGEE, FRONT BLADE URETHANE		
27	86066350	140380	1	STRAP, SQUEEGEE FRONT		
28	86277000	70777	2	SCR, 1/4-20 X 1.5 CARRIAGE SS		
29	86007040	70680	3	SCR, 5/16-18 X 1 THUMB SS TYPE P		
30	86271820	57270	3	NUT, 5/16-18 CAPTIVE "J" PLTD		
31	86271840	57285	2	NUT, 5/16-18 HEX NYLOCK THIN SS		
32	86005650	57031	2	NUT, 5/16-18 HEX		
33	86010670	87029	4	WASHER, 5/16 FLAT SS		
34	86011020	89202	4	WHEEL, 3" DIA. CUSHION RUBBER		
35	86276980	70775	2	SCR, 5/16-18 X 2.00 HHCS SS		
36	86006270	66276	2	PIN, CLEVIS 5/16 X 1.63 PLTD		
37	86069870	140531	2	BRACKET, SQUEEGEE WHEEL		
38	86026540	47399	-	SQUEEGEE ASM 32" SCRUBHEAD		SERVICE ASM

# SQUEEGEE LIFT LINKAGE (LOWER)

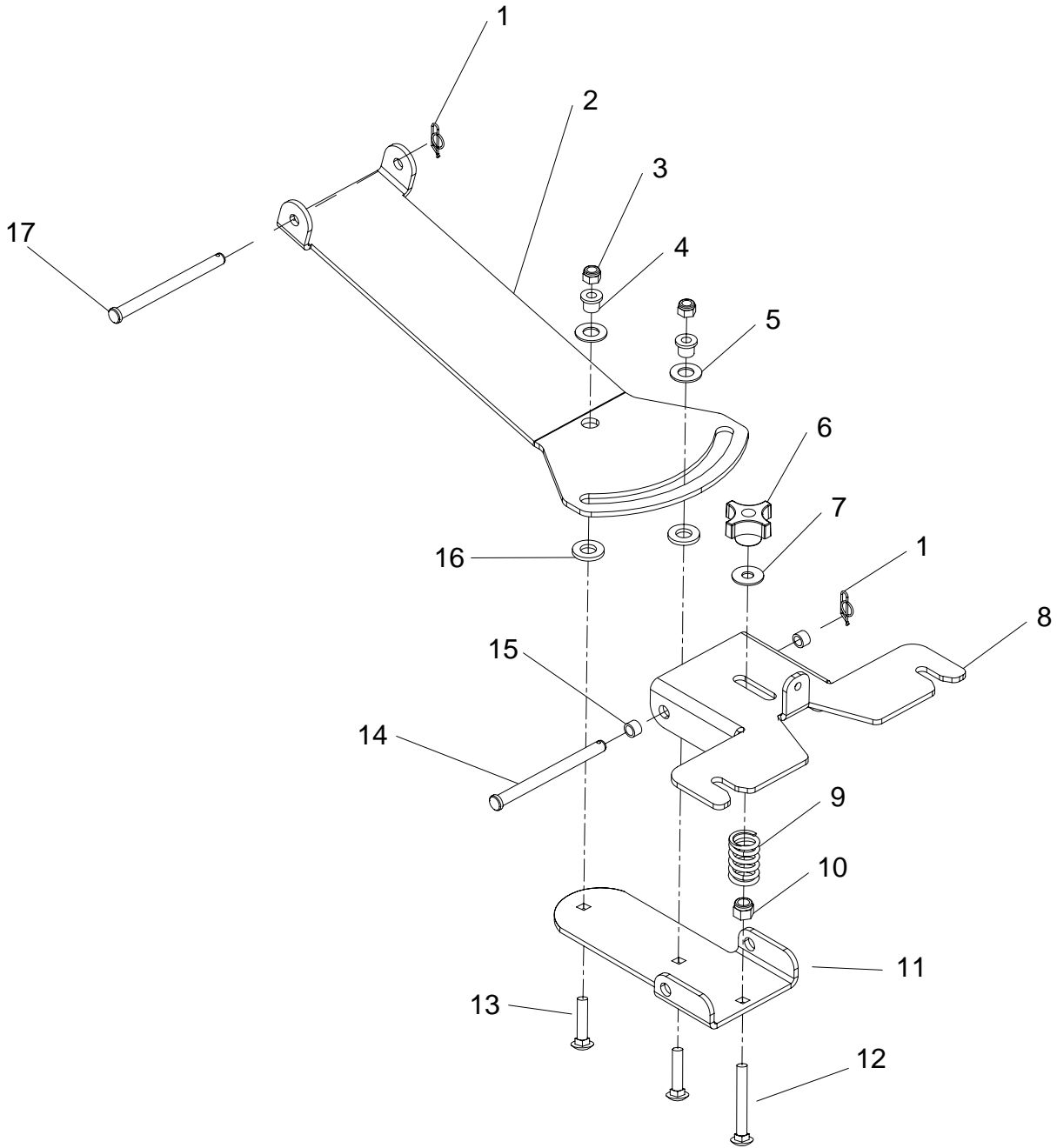

## SQUEEGEE LIFT LINKAGE (LOWER)

REF	PART NO.	PRV NO.	QTY	DESCRIPTION	SERIAL NO. FROM	NOTES:
1	86008670	80606	2	COTTER, 3/8" RING		
2	86069450	140455	1	BRACKET, SQG PIVOT LIFT		
3	86271840	57285	2	NUT, 5/16-18 HEX NYLOCK THIN SS		
4	86228840	09124	2	BEARING, FLANGED .314ID X .502OD		
5	86259420	87232	2	WASHER, THRUST .51ID X 1ODBRO		
6	86009200	81535	1	KNOB, 3/8-16 4 PRONG ALUM		
7	86279510	87171	1	WASHER, 3/8 FLAT		
8	86082150	62922	1	PLATE, SQUEEGEE MOUNT		
9	86007270	730006	1	SPRING, COMP 1.10OD X 2.0L X .148W		
10	86005630	57022	1	NUT, 3/8-16 HEX NYLOCK THIN SS		
11	86072530	14409	1	BRACKET, CAMBER PIVOT		
12	86276870	70748	1	SCR, 3/8-16 X 2.50 CARRIAGE SS		
13	86277130	70795	2	SCR, 5-16-18 X 1.00 CARRIAGE SS		
14	86249060	82061	1	PIN, CLEVIS 3/8 X 4.63 PLTD		
15	86008870	80815	2	BEARING, FLANGED 3/8" ID X 11/16"		
16	86259400	87205	2	WASHER, THRUST .51ID X 1OD BRO		
17	86008860	80808	1	PIN, CLEVIS 3/8" X 5.5" PLTD		

# VACUUM

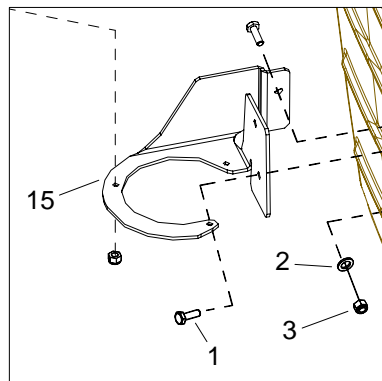
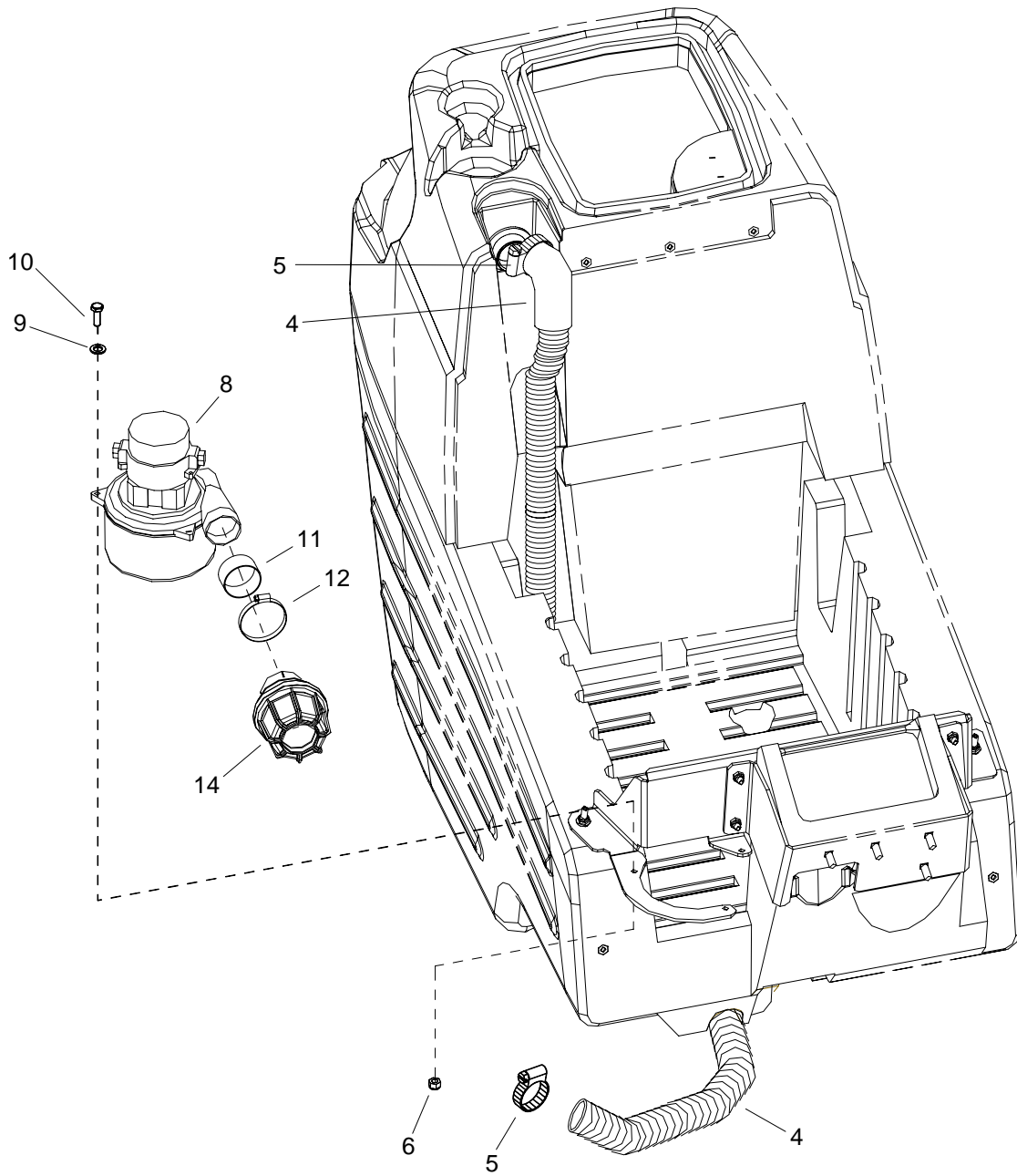

**VACUUM**

REF	PART NO.	PRV NO.	QTY	DESCRIPTION	SERIAL NO. FROM	NOTES:
1	86276920	70755	3	SCR, 3/8-16 X 1 HHCS SS NP		
2	86278910	87003	3	WASHER, 3/8ID X 7/8OD SS		
3	86005630	57022	3	NUT, 3/8-16 HEX NYLOCK THIN SS		
4	86001620	40087	1	HOSE ASM, 1.5 BLK VAC X 67		
5	86002400	20064	2	CLAMP, 2.0" WORM GEAR X .312W		
6	86271870	57290	3	NUT, 1/4-20 HEX NYLOCK THIN SS		
7	-	OPEN	-			
8	86005460	53801	1	VAC MOTOR ASM, 24VDC 3 STAGE		
-	86230810	140551	-	BRUSH SET, 24V 3ST VAC AMETEK		SERVICE ONLY
-	86135310	140686	-	BRUSH SET, 24V/36V VAC WINDSOR	1000122411	SERVICE ONLY
9	86010630	87013	3	WASHER, 1/4ID X 5/8OD SS		
10	86273810	70018	3	SCR, 1/4-20 X 1 HHCS SS		
11	86091170	730174	1	TUBE, 2.0 OD X .05W X 1.0L		
12	86233430	81431	1	CLAMP, 2.50 WORM GEAR		
13	-	OPEN	-			
14	86064910	54194	1	MUFFLER, VAC MOTOR	1000122451	
15	86070630	140704	1	BRACKET, VAC MOUNT 24V	1000122451	SEE COVER & TANK MOUNT PAGE FOR TANK SUPPORT BRKT

# WHEELS AND FRAME

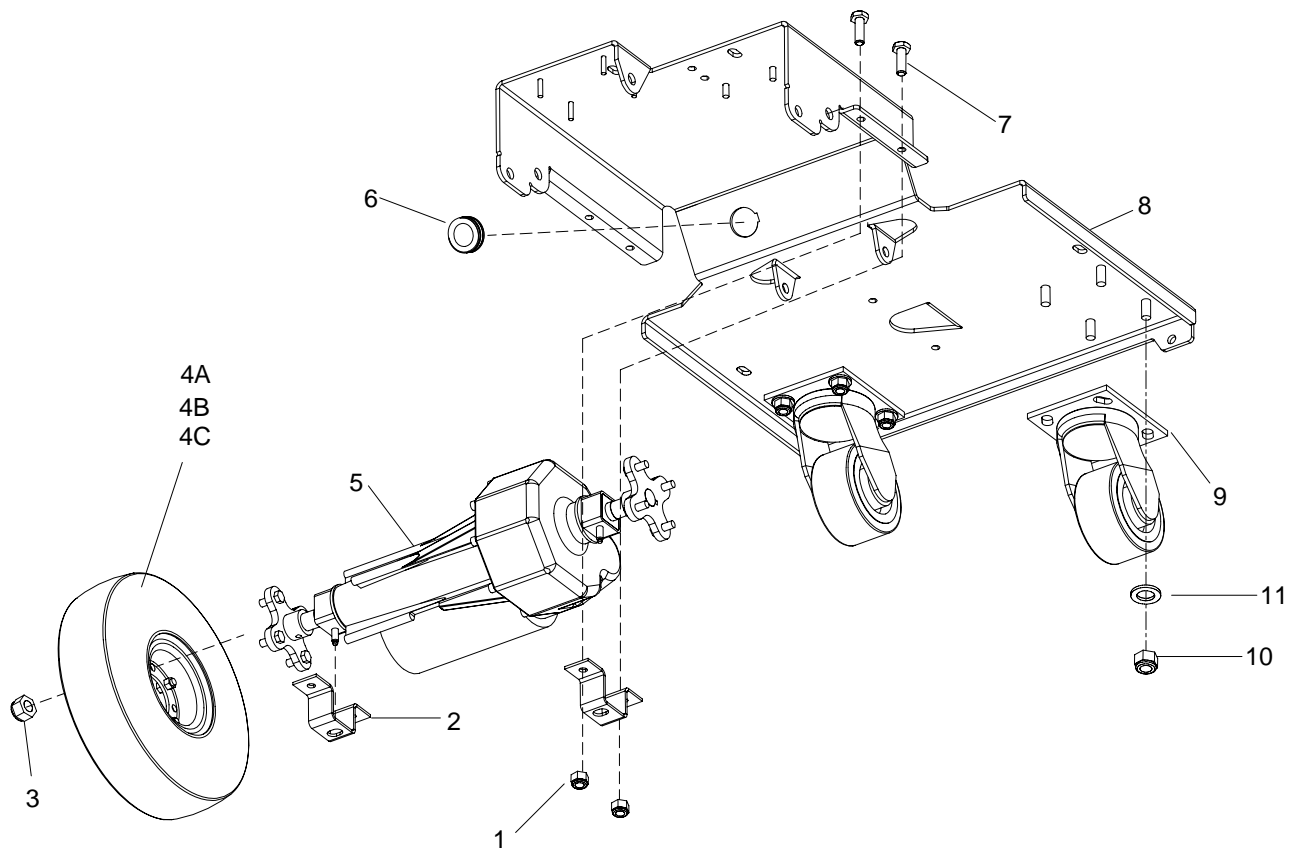

## WHEELS AND FRAME

REF	PART NO.	PRV NO.	QTY	DESCRIPTION	SERIAL NO. FROM	NOTES:
1	86271840	57285	4	NUT, 5/16-18 HEX NYLOCK THIN SS		
2	86230330	14369	2	BRACKET, TRANSAXLE MOUNT		
3	86271860	57289	8	NUT, 5/16-24 HEX NYLOCK SS		
4A	86011050	89212	2	WHEEL ASM, 10" FMFL BLK KNOBBY		
4B	86011040	89211	-	WHEEL ASM, 10" FMFL N-MARKING		OPTIONAL
4C	86137420	830748	-	WHEEL ASM, 10" SOLID SPCL SCBR		OPTIONAL
5	86000800	05128	1	AXLE MOTOR DRIVE, 24VDC		
5A	86216150	140588	-	BRUSH SET, 24V TRANSAXLE		SERVICE ONLY
5B	86004660	47371	-	HUB KIT, 05128 TRANSAXLE	1000094309	SERVICE ONLY
5C	86241840	48091	-	KEY, WOODRUFF .75ID HUB	1000094309	SERVICE ONLY
6	86238430	36191	1	GROMMET, 1.00ID 3/16 GRIP		
7	86006560	70083	4	SCR, 5/16-18 X 1 HHCS SS NP		
8	86092580	62921	1	FRAME, MAIN 24V		
9	86002310	18041	2	CASTER, 4 DIA X 2 W X 3.56R		
10	86005630	57022	8	NUT, 3/8-16 HEX NYLOCK THIN SS		
11	86278910	87003	8	WASHER, 3/8 ID X 7/8 OD SS		

# WIRING- BATTERY

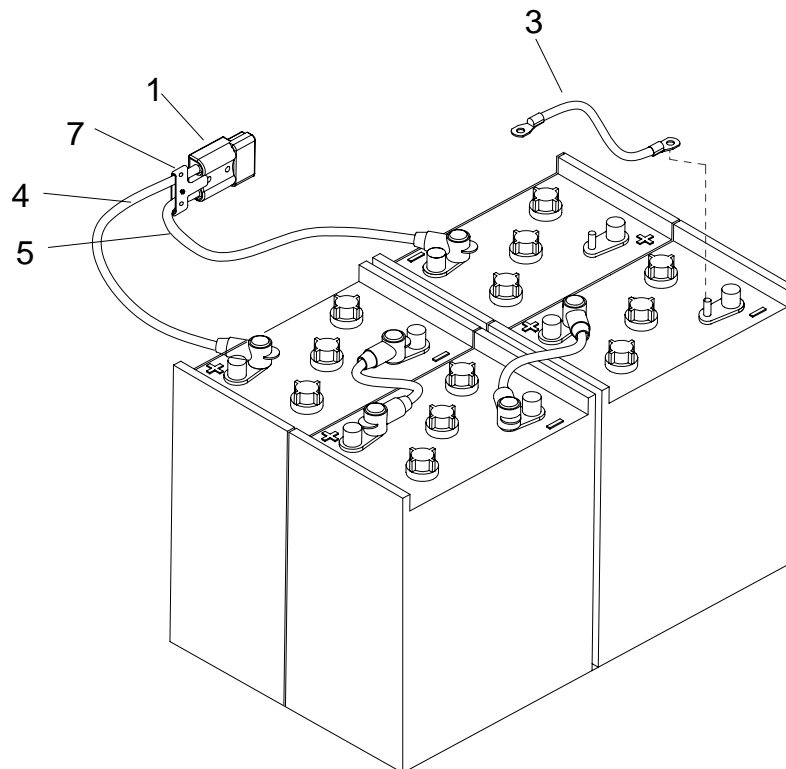
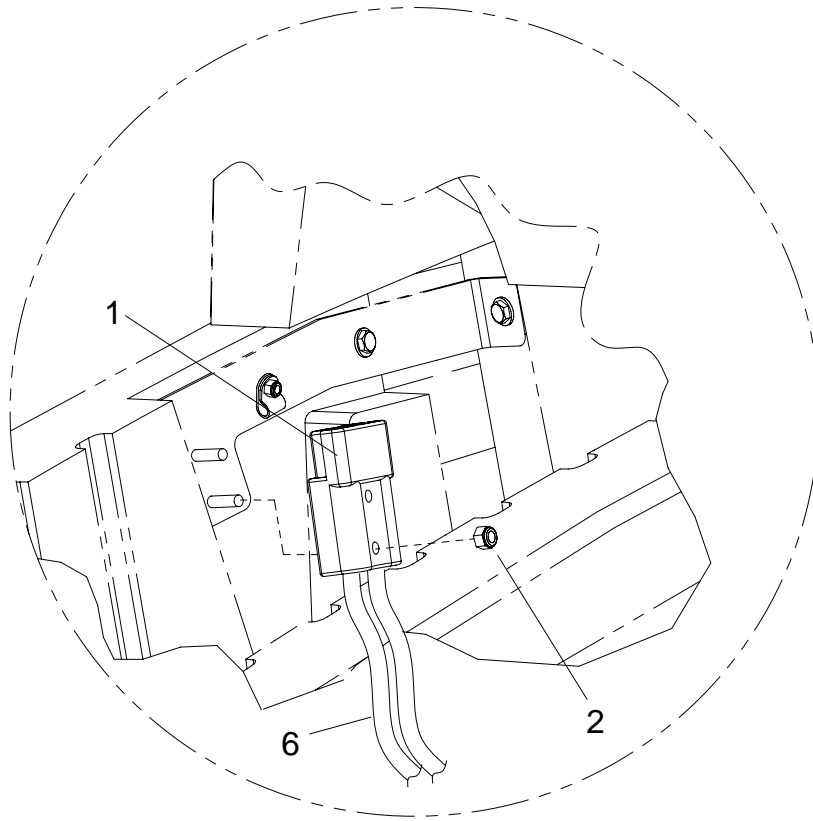

**WIRING-BATTERY**

REF	PART NO.	PRV NO.	QTY	DESCRIPTION	SERIAL NO. FROM	NOTES:
1	86010120	82803	1	CONNECTOR 175 DCA, RED W/O TERMS		
2	86271870	57290	2	NUT, 1/4-20 HEX NYLOCK THIN SS		
3	86002510	23125	3	CABLE ASM, BAT. JUMPER X 15"		
4	86002570	23190	1	WIRE, 4 X 27 RD B CLAMP X C TERM		
5	86002580	23191	1	WIRE, 4 X 27 BK B CLAMP X C TERM		
6	86260520	880384	2	WIRE, 4X67 BK C. TERM 5/16 RING		
7	86233360	28038	1	CLAMP, CABLE KIT SY945		



## WIRING-CONTROL PANEL

REF	PART NO.	PRV NO.	QTY	DESCRIPTION	SERIAL NO. FROM	NOTES:
1	86238990	41442	1	HARNESS, MAIN		
2	86261210	29204	2	DIODE ASM, 76008 X 76008		
3	86003410	29215	1	DIODE ASM, 76075 X 76075		

# WIRING-MAIN HARNESS

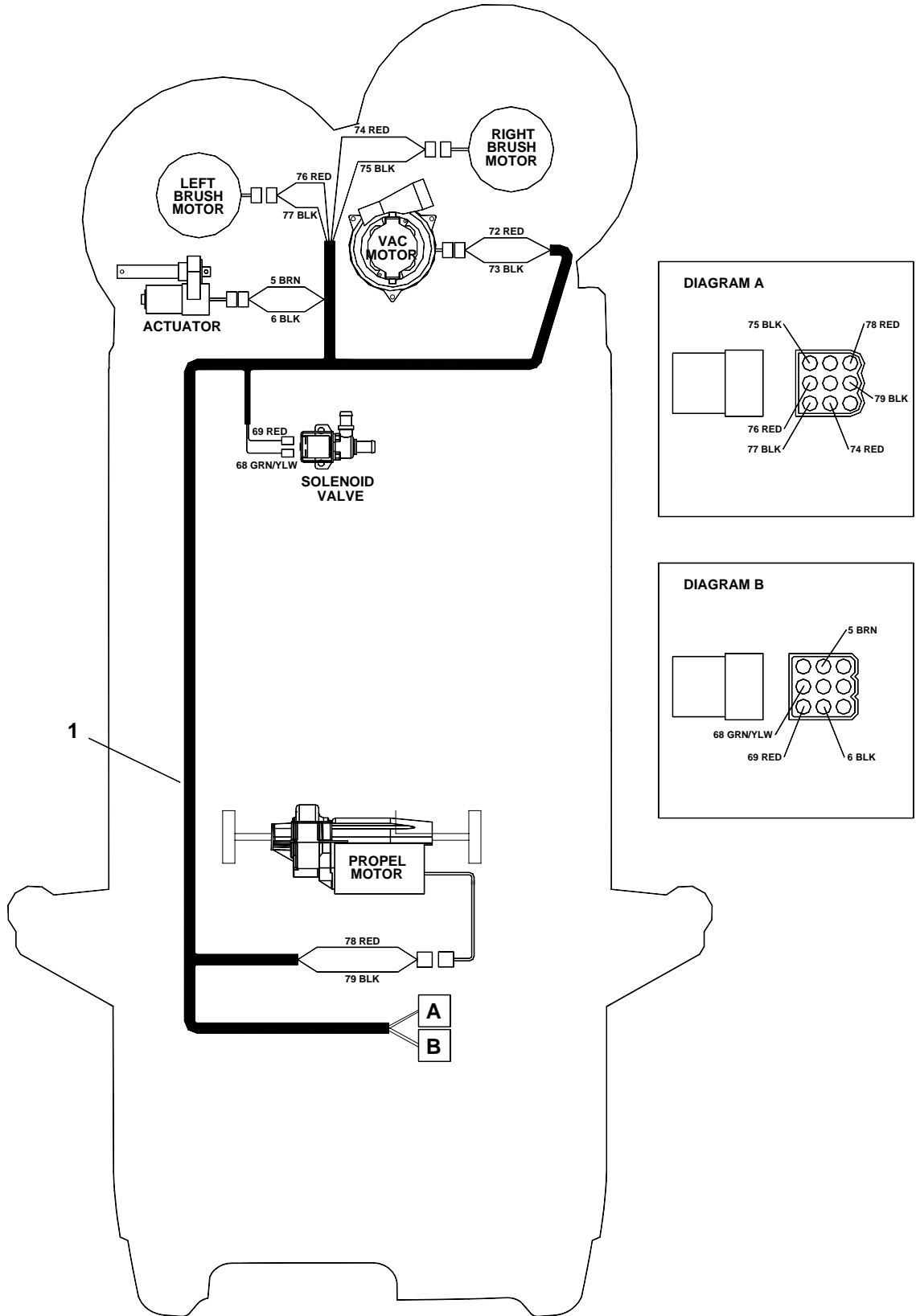

## **WIRING-MAIN HARNESS**

REF	PART NO.	PRV NO.	QTY	DESCRIPTION	SERIAL NO. FROM	NOTES:
1	86238980	41441	1	HARNESS, MAIN		



***THIS PAGE LEFT BLANK INTENTIONALLY***

# BRAKE

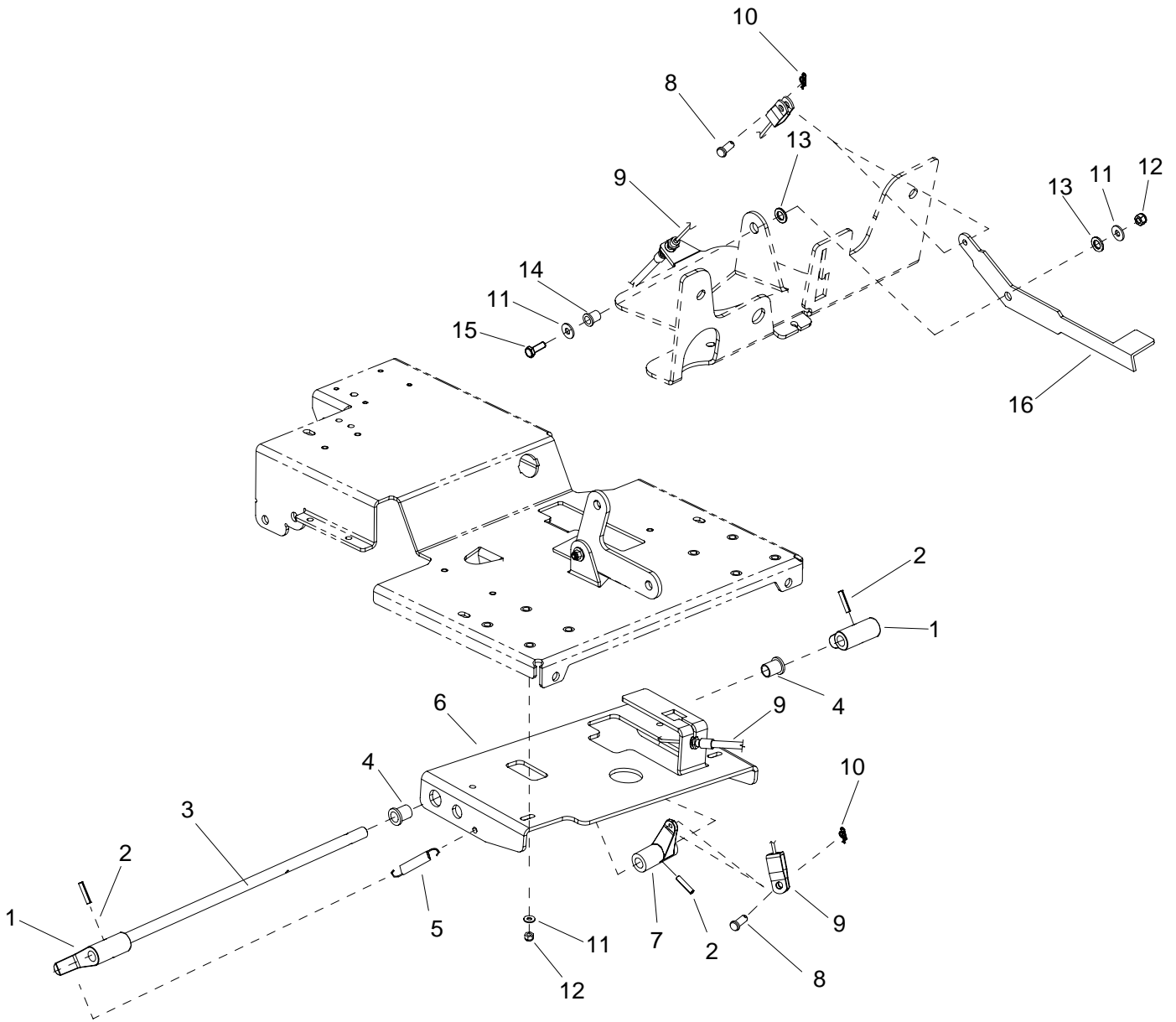

**BRAKE**

REF	PART NO.	PRV NO.	QTY	DESCRIPTION	SERIAL NO. FROM	NOTES:
1	86248370	66381	2	PAD, BRAKE		
2	86006220	66192	3	PIN, ROLL 1/4 X 1.25L		
3	86252070	67486	1	ROD, BRAKE 24V		
4	86231330	14664	2	BUSH, BRZ FLG .63 X .75 X 1.0		
5	86255060	73426	2	SPRING, EXT .43D X 2.50 L X .047 W		
6	86070070	140565	1	BRKT, LOWER BRAKE MOUNT 24V		
7	86234850	27956	1	CRANK, BRAKE		
8	86272610	80669	2	PIN, CLEVIS 5/16" X .75" L PLTD		
9	86231820	27961	1	CABLE, PARK BRAKE		
10	86008660	80605	2	COTTER, 5/16" RING		
11	86010630	87013	6	WASHER, 1/4 ID X 5/8 OD SS		
12	86271870	57290	5	NUT, 1/4-20 HEX NYLOCK THIN SS		
13	86259400	87205	1	WASHER, THRUST .51 ID X 1 OD BRO		
14	86228900	09138	1	BEARING, FLANGED .252ID X .503OD		
15	86273820	70019	1	SCR, 1/4-20 X 1.25 HHCS SS		
16	86077280	51378	2	LEVER, BRAKE		

**EMERGENCY STOP**

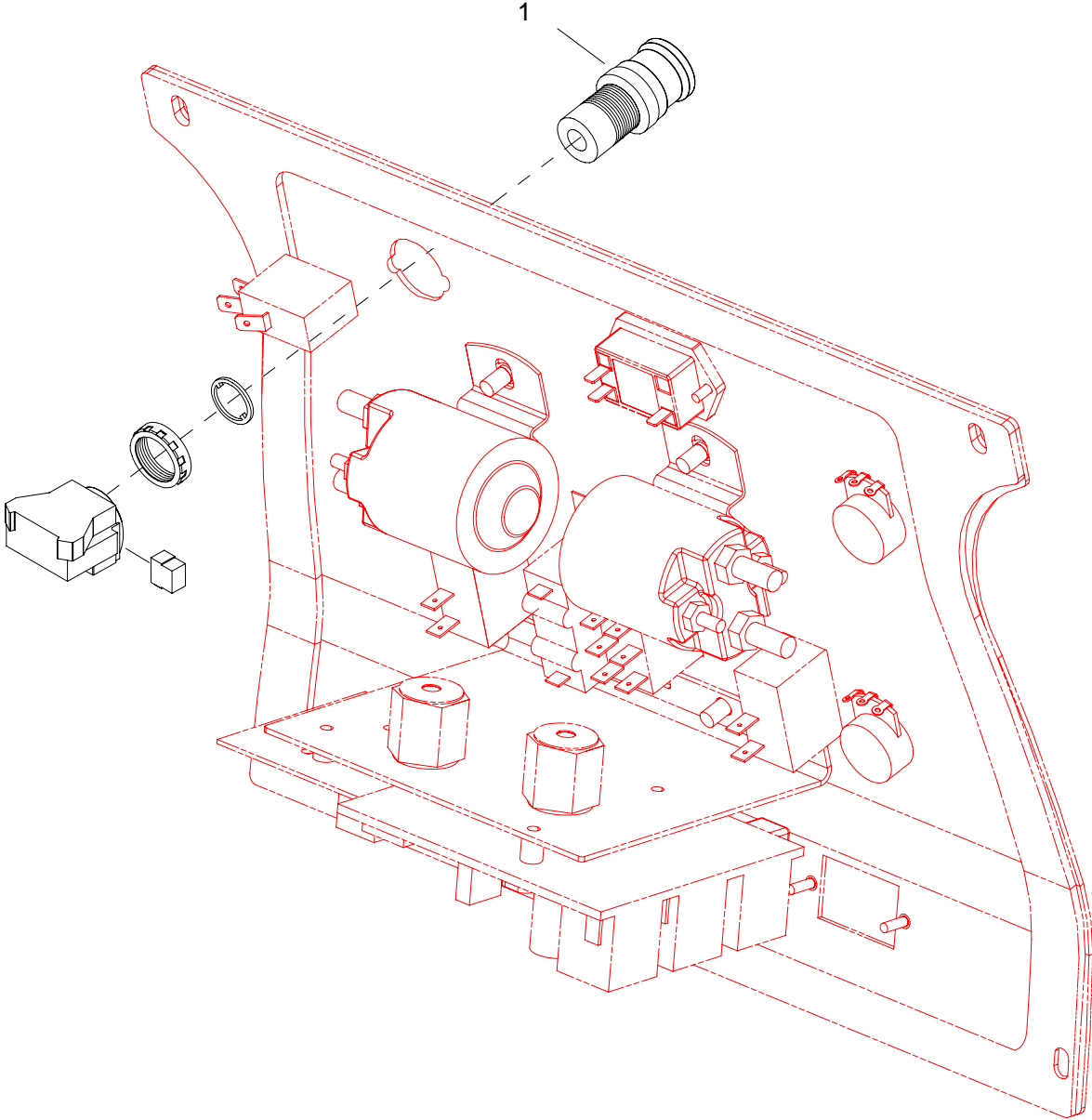

## **EMERGENCY STOP**

REF	PART NO.	PRV NO.	QTY	DESCRIPTION	SERIAL NO. FROM	NOTES:
1	86007180	72160	1	SWITCH, EMERGENCY STOP		
2	86269300	88868	1	WIRE, 16" RED/18 STRIP X STRIP		NOT SHOWN

# ACCESSORY PUMP-OPTION

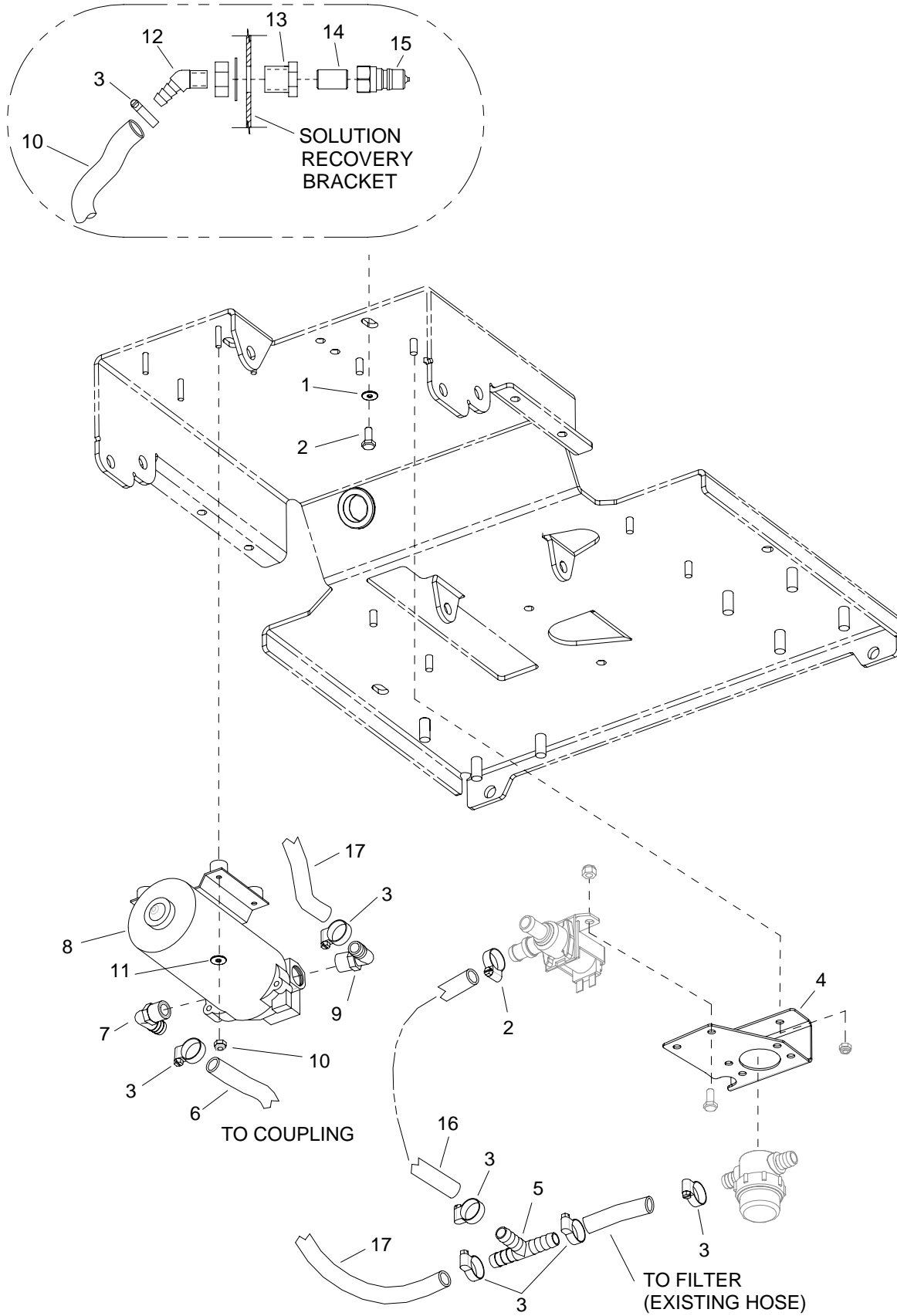

## ACCESSORY PUMP-OPTION

REF	PART NO.	PRV NO.	QTY	DESCRIPTION	SERIAL NO. FROM	NOTES:
1	86010670	87029	1	WASHER, 5/16 FLAT SS		
2	86276780	70728	1	SCR, 5/16-18 X 3/4 HHCS SS		
3	86233150	20042	6	CLAMP, 3/8 HOSE (D-SLOT)		
4	86070140	140573	1	BRKT, FILTER/SOLENOID MOUNT		
5	86240410	40078	1	HOSEBARB, 1/2 TEE		
6	86282200	39617	1	HOSE 3/8 ID X 40" WIRE BOUND		
7	86001550	40043	1	HOSEBARB, 3/8MPT X 3/8 90D		
8	86026370	65180	1	PUMP ASM, 24V ACCESSORY		
9	86197940	40027	1	HOSEBARB, 3/8MPT X 1/2 90 D DL		
10	86270990	57090	4	NUT, 10-32 HEX NYLOCK SS		
11	86010650	87018	4	WASHER, #10 X 9/16 OD		
12	86197620	40038	1	HOSEBARB, 1/4MPT X 3/8 45D DL		
13	86002470	22072	1	COUPLING, 1/4 ANCHOR W/1" HEX		
14	86005590	56014	1	NIPPLE, 1/4 CLOSE		
15	86005580	56012	1	NIPPLE, 1/4 FPT QD		
16	86282110	39571	1	HOSE, 1/2" WIREBOUND X 5.5		
17	86280750	151-38A	1	HOSE, 1/2 WIREBOUND X 21"		
-	86239020	41463	1	HARNESS PUMP KIT ADAPTER		NOT SHOWN
-	86264940	27051	3	CABLE TIE, 11.38" UL/CSA		NOT SHOWN

## SUGGESTED SPARE PARTS

PART NO.	PRV NO.	DESCRIPTION	SERIAL NO. FROM	NOTES:
86001910	14606	BREAKER, 30A 50VDC		
86002000	14717	BREAKER, 3AMP 1681-090-300		
86230810	140551	BRUSH SET, 24V 3ST VAC AMETEK		
86135310	140686	BRUSH SET, 24V/36V VAC WINDSOR	1000122411	
86006420	67393	RELAY, 24VDC 100A		
86007140	72130	SWITCH, SPST 2-POSITION ROCKER		
86009200	81535	KNOB, 3/8-16 4 PRONG		
86007430	730114	BLADE, SQUEEGEE REAR LINATEX		
86008020	73894	BLADE, SQUEEGEE FRONT LINATEX 35"		
86003990	35250	GASKET, DOME		
86236410	34394	FLOAT, VAC SHUT OFF		
86001410	140507	BLADE, 13 IN LEFT		
86001400	140506	BLADE, 13 IN RIGHT		
86007430	730114	SQUEEGEE, REAR BLADE LINTEX		
86008020	73894	SQGE BLADE, FRONT LINATEX 35"		
86007440	730119	SKIRT 26 INCH LEFT		
86007450	730120	SKIRT 26 INCH RIGHT		
86004860	48073	KEY, SWITCH		

NOTES:





Manufacturers of Innovative Building Maintenance Equipment

Windsor Industries, Inc.  
1351 West Stanford Avenue  
Englewood, CO 80110 USA

Phone: 303.762.1800  
FAX: 303.762.0817  
http://www.windsorind.com

### EC Declaration of Conformity

We herewith declare, Windsor Industries, Inc.  
1351 W. Stanford Ave.  
Englewood, CO 80110-5545 USA

that the following product complies with the appropriate essential health and safety requirements of the relevant EC Directives listed below, based on the relevant sections of the applicable EC standards and other normative documents.

**Product:** Saber Cutter 264  
Saber Cutter Deluxe 264  
Saber Cutter Deluxe 324

**Product Identification:** Rated 24 VDC 80 A

**Trademark:**



**Model/Type Ref.:** SCE264  
SCEX264  
SCEX324

**Product Description:** This product is a battery powered, self-propelled, wet floor scrubber intended for commercial use.

**Applicable EC Directives:** EC Machinery Directive  
(89/392/EEC & 91/368/EEC & 93/44/EEC & 93/68/EEC)  
EC Low Voltage Directive  
(73/23/EEC & 93/68/EEC)  
EC Directive of Electromagnetic Compatibility  
(89/336/EEC & 93/68/EEC)

**Applicable Harmonized Standards:** EN 60335-1: 1991  
EN 60335-2-67: 1992  
EN 60335-2-72: 1995  
EN 55022: 1998-09  
EN 55011: 1998-05  
EN 61000-6-2: 1999  
EN 61000-4-2: 1995  
EN 61000-4-3: 1997

  
Authorized Signature

9-10-02  
Date

**Title of Signature:** Vice President, Windsor Industries, Inc.

