

VOYAGER

DUO



Carpet Extractor

Model: VOYDU
10086130

VOYXDU
10086150

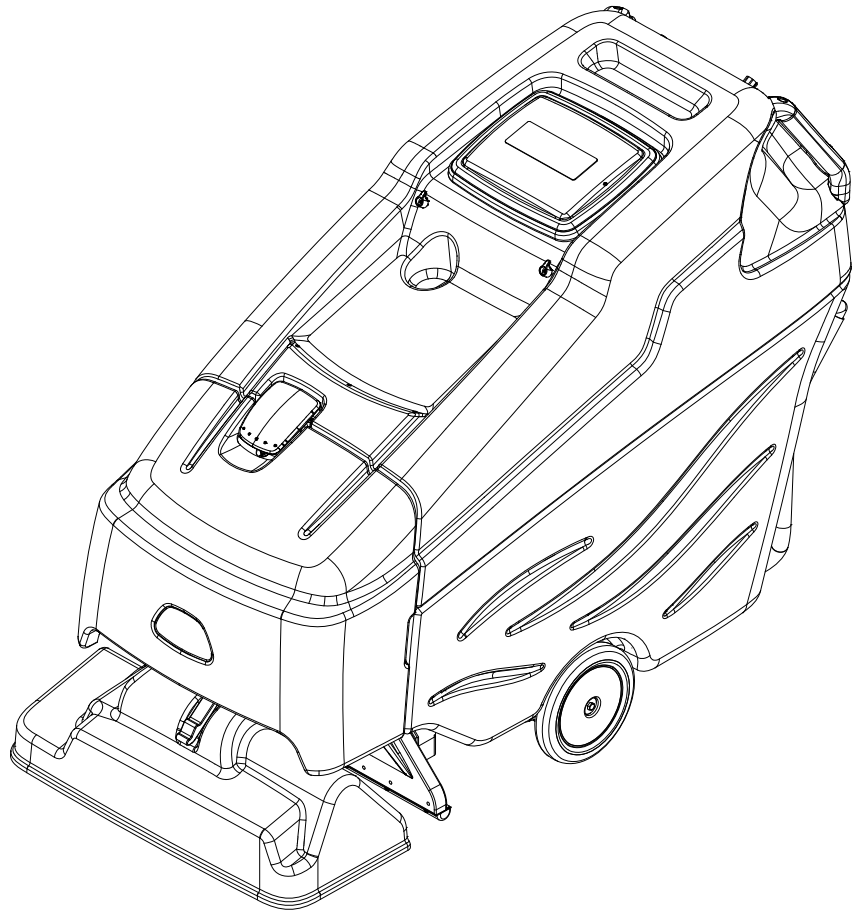

Operating Instructions (ENG)



86292490-AM
11/02/10

MACHINE DATA LOG/OVERVIEW

MODEL _____
DATE OF PURCHASE _____
SERIAL NUMBER _____
SALES REPRESENTATIVE # _____

YOUR DEALER
Name: _____
Address: _____
Phone Number: _____

OVERVIEW

The **Voyager Duo** is a battery powered carpet extractor intended for commercial use. The **Voyager Duo** applies a cleaning solution onto a carpeted floor, sweeps and scrubs the carpet with two counter-rotating brushes and then vacuums the soiled water back into the recovery tank.

TABLE OF CONTENTS

Machine Data Log/Overview.....	2
Table Of Contents.....	3

HOW TO USE THIS MANUAL

How To Use This Manual.....	1-1
-----------------------------	-----

SAFETY

Important Safety Instructions.....	2-1
Hazard Intensity Level.....	2-2
Safety Label Location.....	2-3

OPERATIONS

Technical Specifications.....	3-1
How The Machine Works.....	3-4
Components.....	3-5
Drive Controls.....	3-6
Scrub Controls.....	3-8

Machine Operation.....	3-11
Pre-Run Machine Inspection.....	3-11
Starting Machine.....	3-11
Emergency Stop Procedures.....	3-11
Filling Solution Tank.....	3-12
Normal Scrubbing.....	3-12
To Begin Scrubbing.....	3-13
Priming Pump.....	3-13
To Stop Scrubbing.....	3-13
Emptying and Cleaning Tanks.....	3-14

MAINTENANCE

Service Schedule.....	4-1
Batteries.....	4-2
Scrub Deck.....	4-6
Scrub Brushes.....	4-7
Scrub Motor.....	4-8
Actuator Removal /Replacement.....	4-9
Circuit Protection.....	4-10
Solution Strainer & Pump(Basic).....	4-11
Solution Strainer & Pump(Deluxe).....	4-13
Drive Assembly.....	4-17
Vacuum.....	4-19
Transporting Machine.....	4-22
Machine Troubleshooting.....	4-23

PARTS LIST

Brush Deck.....	5-1
Brush Deck Actuator.....	5-3
Brush Deck Motor.....	5-5
Brush Deck Mounting.....	5-7
Brush Deck Shroud.....	5-9
Brush Deck Lift.....	5-11
Control Handle.....	5-13
Control Panel-Lower (Basic).....	5-15
Control Panel-Lower (Deluxe).....	5-17
Control Panel-Upper (Basic).....	5-19
Control Panel-Upper (Deluxe).....	5-21
Control Panel Mounting.....	5-23
Cover-Front.....	5-25
Decal.....	5-27
Frame-Lower.....	5-29
Frame-Upper.....	5-31
Recovery Tank.....	5-33
Recovery Tank Handle (Basic).....	5-35
Recovery Tank Handle (Deluxe).....	5-37
Solution-Chemical Tanks (Deluxe).....	5-39
Solution Pump.....	5-41
Solution-Chemical Pump (Deluxe).....	5-43
Solution-Chemical Valves (Deluxe).....	5-45
Solution Tank.....	5-47
Spray Jets.....	5-49
Spray Jet Valves (Basic).....	5-51
Spray Jet Valves (Deluxe).....	5-53
Wheel and Drive Assembly.....	5-55
Vacuum Shoe.....	5-57
Vacuum (Basic).....	5-61
Vacuum (Deluxe).....	5-63
Wiring-Battery.....	5-65
Wiring-Control Panel (Basic).....	5-67
Wiring-Control Panel (Deluxe).....	5-69
Wiring-Main Harness (Basic).....	5-71
Wiring-Harness (Deluxe).....	5-72
Wiring Diagram (Basic).....	5-73
Wiring Diagram (Deluxe).....	5-74
Hose Diagram (Basic).....	5-75
Hose Diagram (Deluxe).....	5-76
Suggested Spare Parts.....	5-77
Accessories.....	5-77

OPTIONS & SERIAL NUMBERS

Battery Cart.....	6-2
Battery Cart-Latch and linkage.....	6-4
Battery Cart – Tray.....	6-6
Battery Exchange Option.....	6-8
Emergency Stop-Option.....	6-10
Serial Numbers.....	6-12
Warranty.....	

HOW TO USE THIS MANUAL

This manual contains the following sections:

- HOW TO USE THIS MANUAL
- SAFETY
- OPERATIONS
- MAINTENANCE
- PARTS LIST

The HOW TO USE THIS MANUAL section will tell you how to find important information for ordering correct repair parts.

Parts may be ordered from authorized Windsor dealers. When placing an order for parts, the machine model and machine serial number are important. Refer to the MACHINE DATA box which is filled out during the installation of your machine. The MACHINE DATA box is located on the inside of the front cover of this manual.

MODEL _____
DATE OF PURCHASE _____
SERIAL NUMBER _____
SALES REPRESENTATIVE # _____

The model and serial number of your machine are located below the battery compartment of the machine.

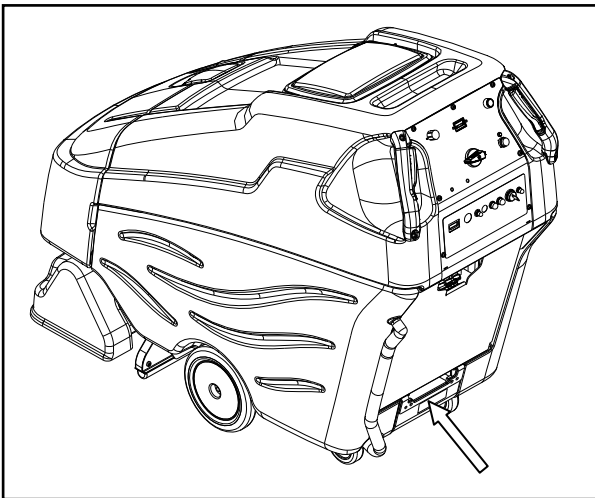

The SAFETY section contains important information regarding hazard or unsafe practices of the machine. Levels of hazards are identified that could result in product or personal injury, or severe injury resulting in death.

The OPERATIONS section is to familiarize the operator with the operation and function of the machine.

The MAINTENANCE section contains preventive maintenance to keep the machine and its components in good working condition. They are listed in this general order:

- Batteries
- Scrub Brushes
- Service Schedule
- Machine Troubleshooting

The PARTS LIST section contains assembled parts illustrations and corresponding parts list. The parts lists include a number of columns of information:

- **REF** – column refers to the reference number on the parts illustration.
- **PART NO.** – column lists the part number for the part.
- **PRV NO.** - reference number.
- **QTY** – column lists the quantity of the part used in that area of the machine.
- **DESCRIPTION** – column is a brief description of the part.
- **SERIAL NO. FROM** – If this column has an (*) and a Reference number, see the SERIAL NUMBERS page in the back of your manual. If column has two asterisk (**), call manufacturer for serial number. The serial number indicates the first machine the part number is applicable to. The main illustration shows the most current design of the machine. When a boxed illustration is shown, it displays the older design.
- **NOTES** – column for information not noted by the other columns.

NOTE: If a service or option kit is installed on your machine, be sure to keep the KIT INSTRUCTIONS which came with the kit. It contains replacement parts numbers needed for ordering future parts.

IMPORTANT SAFETY INSTRUCTIONS

When using an battery powered appliance, basic precaution must always be followed, including the following:

READ ALL INSTRUCTIONS BEFORE USING THIS MACHINE.



To reduce the risk of fire, electric shock, or injury:

Use only indoors. Do not use outdoors or expose to rain.

Use only as described in this manual. Use only manufacturer's recommended components and attachments.

If the machine is **not working properly**, has been dropped, damaged, left outdoors, or dropped into water, return it to an authorized service center.

Do not operate the machine with any openings blocked. Keep openings free of debris that may reduce airflow.

This machine **is not** suitable for picking up hazardous dust.

Machine can cause a fire when operating near flammable vapors or materials. Do not operate this machine near flammable fluids, dust or vapors.

This machine is suitable for commercial use, for example in hotels, schools, hospitals, factories, shops and offices for more than normal housekeeping purposes.

Maintenance and repairs **must be done** by qualified personnel.

If foam or liquid comes out of machine, **switch off immediately**.

Disconnect battery before cleaning or servicing.

Before the machine is discarded, the batteries **must be removed** and properly disposed of.

Make sure all warning and caution labels **are legible and properly attached** to the machine.

During operation, attention shall be paid to other persons, especially children.

Before use all covers and doors shall be put in the positions specified in the instructions.

When leaving unattended, secure against unintentional movement.

The machine shall only be operated by instructed and authorized persons.

When leaving unattended, switch off or lock the main power switch to prevent unauthorized use.

Only chemicals recommended by the manufacturer shall be used.

This appliance has been designed for use with the brushes specified by the manufacturer. The fitting of other brushes may affect its safety.

Do not use on surfaces having a gradient of over 2 degrees.

SAVE THESE INSTRUCTIONS

HAZARD INTENSITY LEVEL

The following symbols are used throughout this guide as indicated in their descriptions:

HAZARD INTENSITY LEVEL

There are three levels of hazard intensity identified by signal words -**WARNING** and **CAUTION** and **FOR SAFETY**. The level of hazard intensity is determined by the following definitions:



WARNING - Hazards or unsafe practices which COULD result in severe personal injury or death.



CAUTION - Hazards or unsafe practices which could result in minor personal injury or product or property damage.

FOR SAFETY: To Identify actions which must be followed for safe operation of equipment.

Report machine damage or faulty operation immediately. Do not use the machine if it is not in proper operating condition. Following is information that signals some potentially dangerous conditions to the operator or the equipment. Read this information carefully. Know when these conditions can exist. Locate all safety devices on the machine. Please take the necessary steps to train the machine operating personnel.

FOR SAFETY:

DO NOT OPERATE MACHINE:

Unless Trained and Authorized.

Unless Operation Guide is Read and understood.

In Flammable or Explosive areas.

In areas with possible falling objects.

WHEN SERVICING MACHINE:

Avoid moving parts. Do not wear loose clothing; jackets, shirts, or sleeves when working on the machine. Use Windsor approved replacement parts.



Batteries emit hydrogen gas. Explosion or fire can result. Keep sparks and open flame away. Keep solution tank in raised position when charging. Keep sparks and flames away from the batteries. Do not smoke around batteries.



Disconnect batteries before working on machine. Only qualified personnel should work inside machine. Always wear eye protection and protective clothing when working on or near batteries. Avoid skin contact with the acid contained in the batteries.



Never allow metal to lie across battery tops.

SAFETY LABEL LOCATION

NOTE: These drawings indicate the location of safety labels on the machine. If at any time the labels become illegible, promptly replace them.

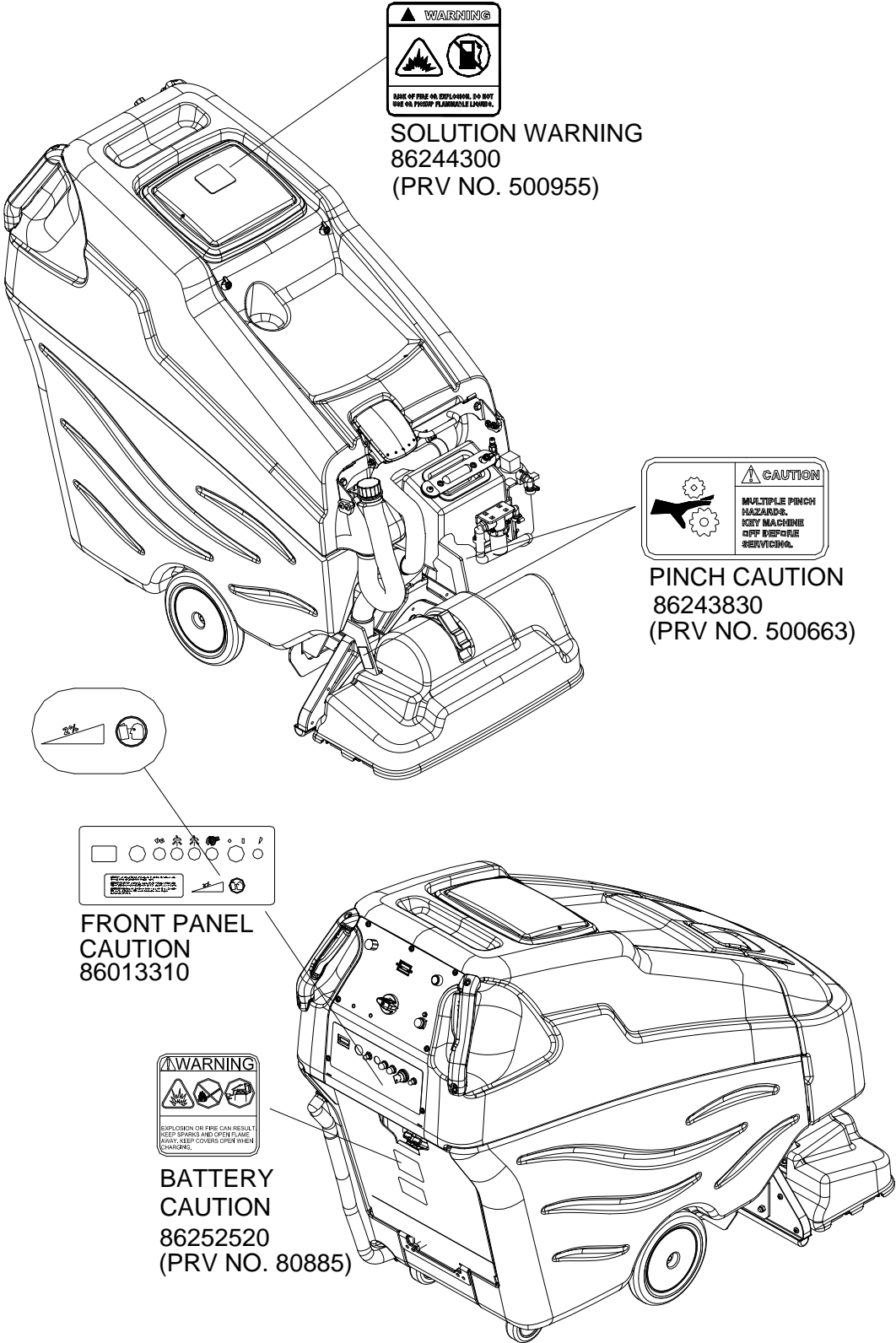

SOLUTION WARNING
86244300
(PRV NO. 500955)

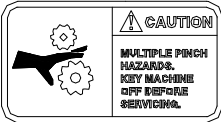

PINCH CAUTION
86243830
(PRV NO. 500663)

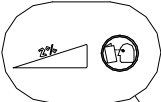

FRONT PANEL CAUTION
86013310



BATTERY CAUTION
86252520
(PRV NO. 80885)

NOTES:

TECHNICAL SPECIFICATIONS - BASIC

ITEM	DIMENSION/CAPACITY
Nominal Power	1855 W
Rated Voltage	36 Volts DC
Rated Amperage	51.5 amps
Batteries	3 X12 Volt 195-215 AH @ 20 hr. rate
Battery Compartment Dimensions	23.5 in. x 15.5 in. x 16.5 in. tall (600 mm x 400 mm x 420 mm)
Propelling Motor	.75 HP (560 W)
Mass (GVW)	1042 lbs (473 kg)
Weight Empty Without Batteries	418 lbs (190 kg)
Solution Control	Metered flow with automatic shut-off in neutral and reverse
Spray Pump Pressure	100 psi (688 Kpa)
Solution Capacity	31.4 gal (120 Liter)
Spray Jets - Interim	2 Jets with total flow of 0.24 gal/min (0.9 Liter/min)
Spray Jets - Extraction	4 Jets with total flow of 1.05 gal/min (4.0 Liter/min)
Recovery Capacity	21 gal (79 Liter)
Vacuum Motors	2 x .75 Hp (560 W)
Scrub Brush Diameter	3.38" Inch (85.5 mm)
Scrub Brush Motor	1 x .5 Hp (375 W)
Scrub Brush Pressure	Floating
Scrub Brush Speed	1084 rpm
Tires	9 in. (228mm) Solid Gray non-marking
Foundation Pressure	596 psi (4.2 Mpa)
Maximum (Transport) Speed	Propel = 2.4 mph (3.8 Km/hr)
Scrubbing Speed	Interim = 110 Ft/min (2.0 Km/hr) Extract = 55 Ft/min (1.0 Km/hr)
Theoretical Coverage (with 2" Overlap)	Interim = 12100 ft ² /hr (1125 M ² /hr) Extract = 6050 ft ² /hr (562 M ² /hr)
Frame Construction	Powder coated steel
Minimum Aisle U-Turn Width	62.5 in. (1.6 Meter)
Maximum Rated Climb And Descent Angle	6 degrees

TECHNICAL SPECIFICATIONS - DELUXE

ITEM	DIMENSION/CAPACITY
Nominal Power	2002 W
Rated Voltage	36 Volts DC
Rated Amperage	56 amps
Batteries	3 X12 Volt 195-215 AH @ 20 hr. rate
Battery Compartment Dimensions	23.5 in. x 15.5 in. x 16.5 in. tall (600 mm x 400 mm x 420 mm)
Propelling Motor	.75 HP (560 W)
Mass (GVW)	1106 lbs (502 kg)
Weight Empty Without Batteries	429 lbs (195 kg)
Solution Control	Metered flow with automatic shut-off in neutral and 0:1reverse
Spray Pump Pressure	100 psi (688 Kpa)
Solution Capacity	31.4 gal (120 Liter)
Spray Jets - Interim	2 Jets with total flow of 0.24 gal/min (0.9 Liter/min)
Spray Jets - Extraction	4 Jets with total flow of 1.05 gal/min (4.0 Liter/min)
Recovery Capacity	21 gal (79 Liter)
Vacuum Motors	2 x .75 Hp (560 W)
Scrub Brush Diameter	3.38" Inch (85.5 mm)
Scrub Brush Motor	1 x .5 Hp (375 W)
Scrub Brush Pressure	Floating
Scrub Brush Speed	1084 rpm
Tires	9 in. (228mm) Solid Gray non-marking
Foundation Pressure	596 psi (4.2 Mpa)
Maximum (Transport) Speed	Propel = 2.4 MPH (3.8 Km/hr)
Scrubbing Speed	Interim = 110 Ft/min (2.0 Km/hr) Extract = 55 Ft/min (1.0 Km/hr)
Theoretical Coverage (with 2" Overlap)	Interim = 9900 ft ² /hr (920 M ² /hr) Extract = 4950 ft ² /hr (460 M ² /hr)
Frame Construction	Powder coated steel
Minimum Aisle U-Turn Width	62.5 in. (1.6 Meter)
Maximum Rated Climb And Descent Angle	6 degrees
Chemical Tank "A" Capacity	2.06 Gal (7.78L)
Chemical Tank "B" Capacity	0.55 Gal (2.09L)
Chemical "A" Mix Ratio	16:1 Nominal
Chemical "B" Mix Ratio	64:1 Nominal

TECHNICAL SPECIFICATIONS

ITEM	MEASURE
Height	43 inches (1100 mm)
Length	59 inches (1500 mm)
Width	32 inches (800 mm)
Width of scrub path	24 inches (600mm)

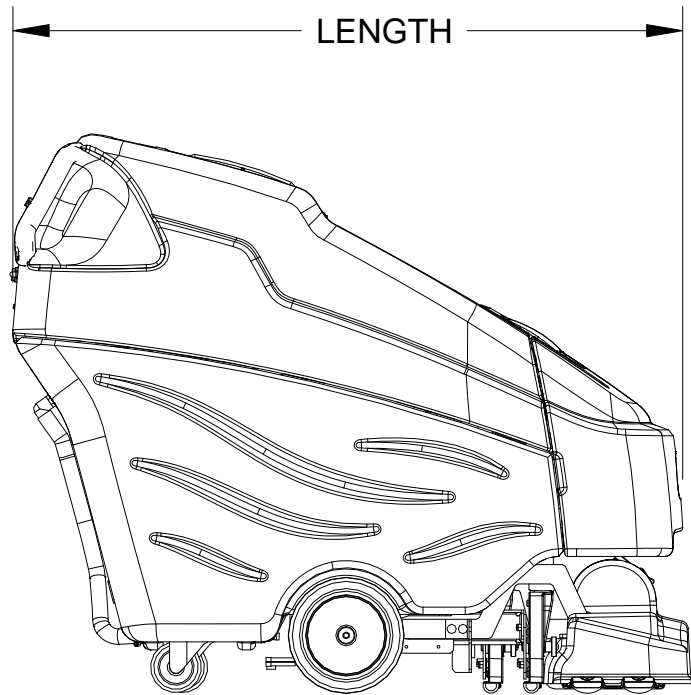
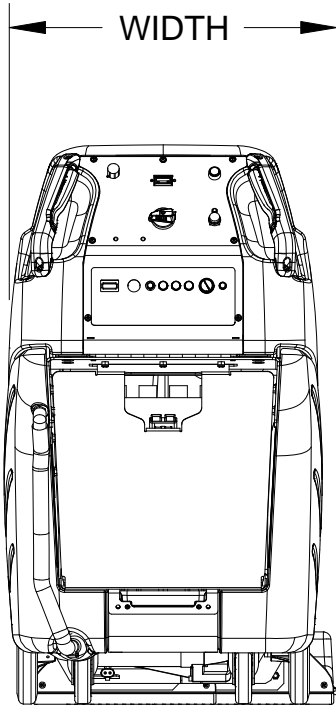

SPECIAL NOTES:

The sound pressure level at the operator's ear was measured to be 70.5 dBA. This was a nearfield, broad-band measurement taken in a typical industrial environment on a tile floor. This appliance contains no possible source of impact noise. The instantaneous sound pressure level is below 63 Pa.

The weighted root mean square acceleration at the operator's arms was measured to be below 2.5m/s^2 . This was a tri-axial, third-octave-band measurement made during normal operation on a composite tile floor. The measurement and related calculations were made in accordance with ANSI S3.34-1986.

HOW THIS MACHINE WORKS

The Machine is a battery powered, self-propelled Carpet Maintainer and Carpet Extractor intended for commercial use.

The machine is designed to maintain your carpet using the Encapsulating Interim Carpet Cleaning Process. By using the Interim Carpet Maintainer in conjunction with Windsor Red Carpet Encapsulating Interim Cleaning (W450-4) or Encapsulating Interim Cleaning with Carpet Protection (W455-4) chemical solution, you can perform a regular light cleaning and grooming of your carpet very quickly, and have the carpet dry and ready for traffic within 30 minutes.

The machine is also designed to restore your carpet using carpet extraction chemicals. The machine is designed to apply cleaning solution onto carpeted floor, scrub the carpet with two counter-rotating brushes, and then vacuum the soiled water back into the recovery tank.

DELUXE ONLY

The machine can be used to perform a "One step" or "Two step" carpet restoration. Using the "One step" process, the carpet is restored with a deep extraction chemical. Using the "Two step" process, the carpet is first scrubbed with a pre-spray and then scrubbed again with a neutralizing rinse.

The machine's primary systems are the solution system, *chemical injection system (Deluxe)*, scrub system, recovery system and operator control system.

The function of the solution system is to store water and deliver solution to the appropriate spray jets. The solutions system consists of the solution tank, strainer, pump, solenoid valves, spray jets and controls. The solution tank stores water until it is delivered through the strainer and pump to the solenoid valves and spray jets. The strainer protects the pump from debris. The solenoid valves automatically prevents solution flow unless the scrub brushes are turned on and the machine is being propelled forward. The solution pump switch controls the cleaning solution flow.

DELUXE ONLY

The function of the chemical injection system is to deliver the appropriate chemical into the solution system to be applied to the carpet. The chemical injection system consists of the "A" chemical tank, "B" chemical tank, chemical selector valve, chemical pump, and the mixing sector. The "A" chemical tank stores either encapsulating interim chemical, pre-spray "Two step" chemical or neutralizing rinse "Two step" chemical. The "B" chemical tank stores the deep extraction chemical. The chemical selector valve controls which chemical is delivered into the system depending on the function knob on the control panel. The chemical pump draws from the tanks and delivers it into the solution system. The mixing sector allows the chemical to thoroughly mix with the water before being delivered to the carpet.

The function of the scrub system is to scrub the carpet, mix the cleaning solution with the soil and lift and groom the carpet pile. The scrub system consists of two cylindrical brushes, motor, lift actuator, and controls. The brushes scrub the carpet as the motor drives the brushes. The counter-rotating action of the brushes grooms the carpet pile. The rotor actuator switch controls the lift actuator and brush motor to lower the deck and turn the motor on, or raise the deck and turn the motor off. The brush motor will automatically turn off when the throttle switches are in neutral.

The function of the recovery system is to vacuum the soiled water back into the recovery tank. The recovery system consists of the vacuum shoes, vacuum motor(s), float ball filter, recovery tank and controls. The vacuum shoes extract the dirty solution from the carpet as the machine moves forward. The vacuum motor(s) provide suction to draw the dirty solution off the floor and into the recovery tank. The float ball filter protects the vacuum fan from debris and foam. The recovery tank stores the dirty solution.

The function of the operator control system is to control the direction and speed of the machine. The control system consists of the reverse switch, throttle switch, speed control knob, propel controller, and drive wheels. The reverse switch signals forward or reverse direction. The propel controller interprets signals from the throttle switches, and speed control knob to command the drive wheels to propel or slow the machine.

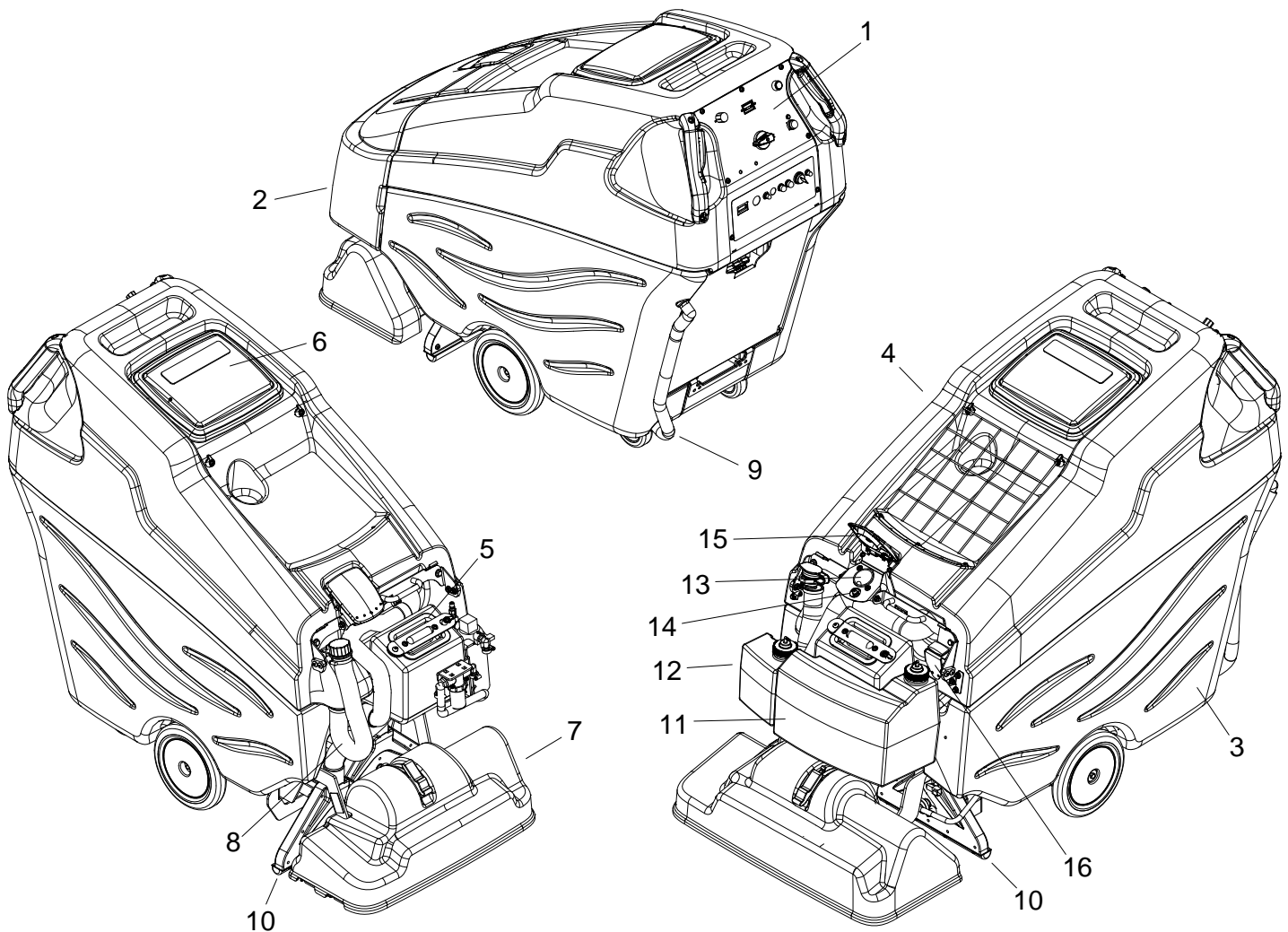

-
- | | |
|-----------------------------------------------------------------------------------------------------------------------------------------------------------------------------------------------------------------------------------------------------------------------------|-----------------------------------------------------------------------------------------------------------------------------------------------------------------------------------------------------------------------------------------------------------------------------------------------------------------------------------------------------------------------------------------------------|
| <ul style="list-style-type: none"> 1. Control Panel-Drive/Scrub 2. Front Cover 3. Solution Tank 4. Recovery Tank 5. Solution Fill Cover 6. Recovery Dome 7. Scrub Deck 8. Recovery Drain Hose | <ul style="list-style-type: none"> 9. Solution Drain Hose 10. Vacuum Shoes 11. Chemical Tank "A" (Deluxe) 12. Chemical Tank "B" (Deluxe) 13. Accessory Vacuum Port (Deluxe) 14. Accessory Water Port (Deluxe) 15. Accessory Port Cover (Deluxe) 16. Switch, Chemical Prime and flush for "A" and "B" Systems (Deluxe) |
|-----------------------------------------------------------------------------------------------------------------------------------------------------------------------------------------------------------------------------------------------------------------------------|-----------------------------------------------------------------------------------------------------------------------------------------------------------------------------------------------------------------------------------------------------------------------------------------------------------------------------------------------------------------------------------------------------|

DRIVE CONTROLS

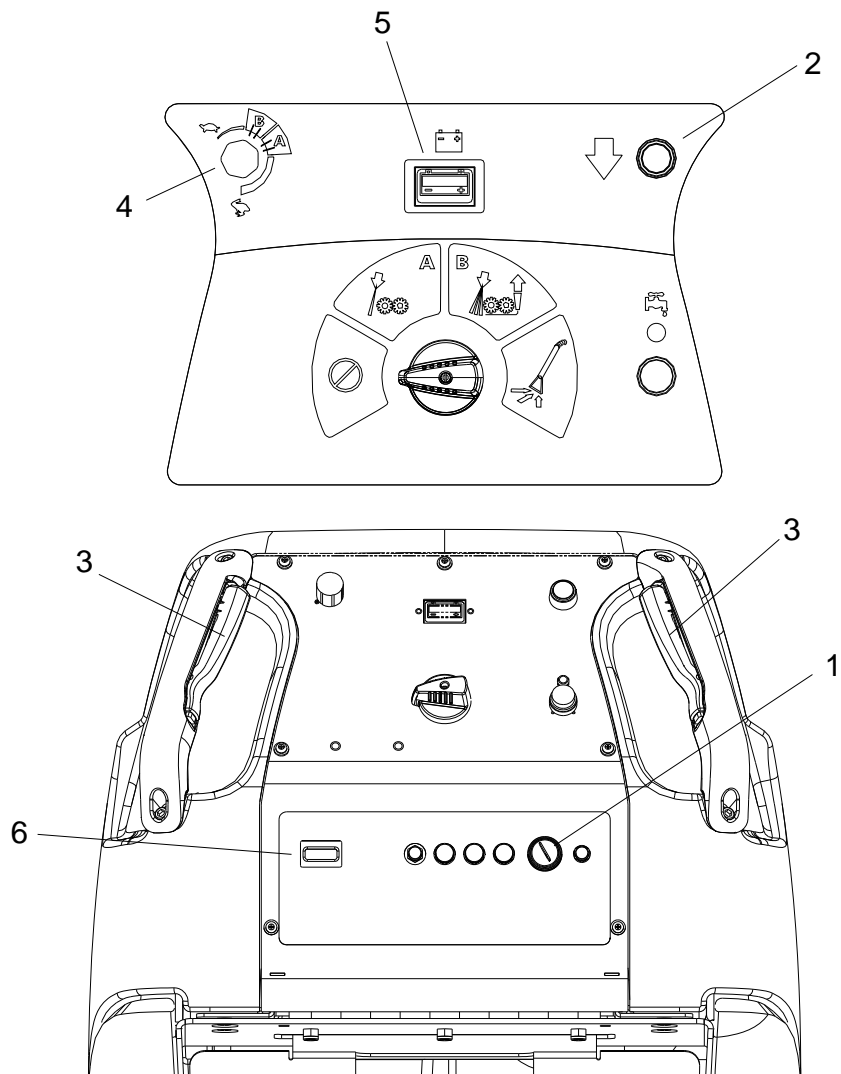

1. Key Switch
2. Reverse Switch
3. Throttle Switches
4. Speed Control Knob

5. Battery Discharge Indicator
6. Hour Meter
7. E-Stop Button (Deluxe)

1. KEY SWITCH

Controls the power for machine functions.

To turn the machine power on, rotate key clockwise.

To turn the machine off, rotate key counterclockwise.

2. REVERSE BUTTON

Controls the direction of travel of the vehicle.

To travel in reverse, press the button and press either of the throttle switches.

To travel forward, release the button and press either of the throttle switches.

3. THROTTLE SWITCHES

Propel the vehicle with the speed control knob setting selected. Pressing either of the switches causes the machine to travel in the direction selected by the Reverse Button.

To travel, press either of the throttle switches.

To stop travel, release both throttle switches.

4. SPEED CONTROL KNOB

Controls the speed of the machine. Speed range B is intended for carpet extraction. Speed A is intended for interim carpet cleaning. Faster speeds are recommended for transport only, not scrubbing.

To increase speed, turn the knob clockwise.

To decrease speed, turn the knob counter clockwise.

Speeds can be adjusted at any time, whether machine is moving or not.

5. BATTERY DISCHARGE INDICATOR

Indicates the charge level of the batteries.

The meter display is divided into 10 vertical bars. All bars illuminated indicate full charge. Bars flashing near the left side indicate the batteries should be charged. Further operation of the machine could damage the machine and the batteries. Bars flashing also indicate that machine has been left unattended with key on for more than 15 minutes. Turn key off then on to reset.

6. HOUR METER

Records the number of hours the machine has been in operation (scrubbing). This information is useful in determining when to service the machine.

7. EMERGENCY STOP SWITCH (DELUXE)

This safety feature is designed to cut all power to the machine at any time.

To shut the machine power off, push the Emergency Stop Switch.

To reset the machine, rotate the switch clockwise.

SCRUB CONTROLS

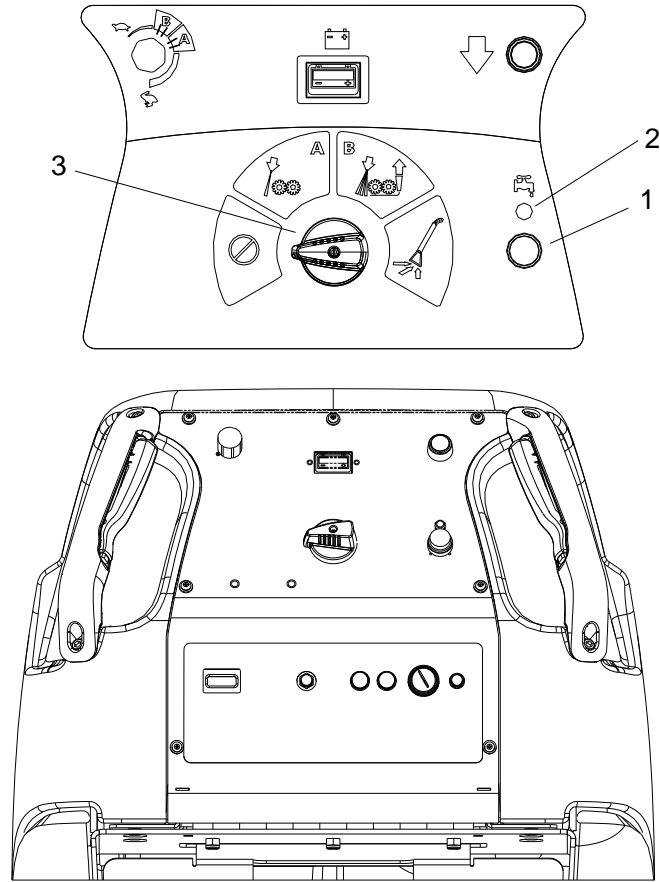

-
1. *Solution Pump Switch*
 2. *Solution Pump Indicator*

3. *Function Switch*

1. SOLUTION PUMP SWITCH

Controls power to the spray pump.

If the throttle is in neutral, or reverse control button is in reverse position, the flow is automatically interrupted. This feature prevents application of solution without scrubbing it into carpet.

2. SOLUTION PUMP INDICATOR LIGHT

The solution pump indicator light is illuminated green when the pump is on.

3. SCRUB DECK ROTARY SWITCH (BASIC)

Raises and lowers the scrub deck, and turns the scrub brush motors on and off, and controls the solution solenoids.

For interim or "A" mode, rotate the function knob to the "A" position. The scrub deck will lower and the scrub motor will turn on and the interim solenoid will open and spray will flow through the interim jets. The brush motor will automatically turn off in neutral. The interim solenoid will shut off in neutral or reverse.

To raise the deck, turn off the brush motor and solenoid(s). Rotate the knob to the off position to the far counter clockwise position.

For extraction or "B" mode, rotate the function knob to the "B" position. The scrub deck will lower and the scrub motor will turn on and the extraction solenoid and interim solenoid will open and spray will flow through the extraction and interim jets and the vacuum motor will run. The brush motor will automatically turn off in neutral. The extraction and interim solenoid will shut off in neutral or reverse.

To raise the deck, turn off the brush motor and solenoid(s). Rotate the knob to either the off position to the far counter clockwise position, or rotate the knob to the far clockwise position to the accessory mode so that the vacuum motor continues to run to keep any excess soiled solution from dripping back onto the floor.

To use the machine with an accessory hand tool or wand, rotate the knob fully clockwise to the accessory position. Only the vacuum motor and pump will run. Connect the solution hose of the accessory tool to the solution accessory port. The fitting is 1/8" male quick disconnect. If needed to adapt to 1/4" male quick disconnect (see Suggested Spare Parts for part number).

To connect the vacuum hose, disconnect the hose assembly from the lower connection of the "Y" tube junction. Use adaptor to join the two hose cuffs together (See Accessories page).

SCRUB CONTROLS

SCRUB DECK ROTARY SWITCH (DELUXE)

Raises and lowers the scrub deck, and turns the scrub brush motors on and off, and controls the solution solenoids.

For interim/pre-spray "A" mode, rotate the function knob to the "A" position. The "A" chemical will be drawn from its tank and delivered to the solution system. The scrub deck will lower and the scrub motor will turn on and the interim/pre-spray solenoid will open and spray will flow through the jets. The brush motor will automatically turn off in neutral. The spray solenoid will shut off in neutral or reverse.

To raise the deck, turn off the brush motor and solenoid(s). Rotate the knob to the off position to the far counter clockwise position.

For extraction or "B" mode, rotate the function knob to the "B" position. The "B" chemical will be drawn from its tank and delivered to the solution system. The scrub deck will lower and the scrub motor will turn on and the extraction solenoid and interim/pre-spray solenoid will open and spray will flow through the extraction and interim jets and the vacuum motor will run. The brush motor will automatically turn off in neutral. The extraction and interim/pre-spray solenoid will shut off in neutral or reverse.

To raise the deck, turn off the brush motor and solenoid(s). Rotate the knob to either the off position to the far counter clockwise position, or rotate the knob to the far clockwise position to the accessory mode so that the vacuum motor continues to run to keep any excess soiled solution from dripping back onto the floor.

To use the machine with an accessory hand tool or wand rotate the knob fully clockwise to the accessory position. Only the vacuum motor and pump will run. Connect the solution hose of the accessory tool to the solution accessory port. The fitting is 1/8" male quick disconnect. If needed to adapt to 1/4" male quick disconnect (see Suggested Spare Parts for part number). **NOTE:** *The accessory port is only supplied with water from the solution tank. No chemical is injected.*

To connect the vacuum hose, open the accessory port cover and insert the wand vacuum hose fully into the port.

MACHINE OPERATION

PRE-RUN MACHINE INSPECTION

Do a pre-run inspection to find possible problems that could cause poor performance or lost time from breakdown. Follow the same procedure each time to avoid missing steps.

NOTE: See maintenance section for pre-run machine inspection checklist items.

STARTING MACHINE

NOTE: Perform pre-run machine check before operating machine.

FOR SAFETY: Before starting machine, make sure that all safety devices are in place and operating properly.

1. Turn the machine power on by turning key switch clockwise to the "I" (on) position.
2. Check the position of the Reverse Button to make sure the machine will travel in the direction intended.
3. Check the position of the speed control knob to make sure the machine will travel at the intended speed.
4. Press either throttle Switch.

EMERGENCY STOP PROCEDURES

1. Release both the throttle switches.
2. Turn machine power off with key switch by turning key switch counterclockwise to the "O" (off) position.

DELUXE

1. Release both the throttle switches.
2. Turn machine power off with key switch by turning key switch counterclockwise to the "O" (off) position.
3. Push E-Stop button in.
4. To reset the E-stop button, rotate counter clockwise and the switch will pop back out.

MACHINE OPERATION

FILLING SOLUTION TANK

FOR SAFETY: Before leaving or servicing machine; stop on level surface, turn off machine and remove key.

1. Turn the machine power off.
2. Remove the front cover and the solution fill lid.
3. Fill the solution tank with clean water. (See the Technical Specifications chart for exact capacity). The water must not be hotter than 140° F (60°C) to prevent damage to the tank.
4. Replace the solution fill lid and front cover.

DELUXE

1. Turn the machine power off.
2. Remove the front cover and the solution fill lid.
3. Fill the "A" tank with either encapsulating interim carpet cleaning or prespray chemical.
4. Fill the "B" tank with extraction chemical.
5. Turn machine power on.
6. Prime chemical system by holding the prime switch to the "A" position for 30 seconds then holding the prime switch to the "B" position for 30 seconds. If using only one chemical tank, prime only that system.

! WARNING: Flammable materials can cause an explosion or fire. Do not use flammable materials in the tanks.

NORMAL SCRUBBING

Plan the scrubbing pattern in advance. For efficient operation, the runs should be the longest possible without turning, stopping, or raising or lowering scrub deck. The longest track is around the perimeter of the area to be cleaned and a collapsing rectangle pattern is most efficient.

In order to achieve the best possible results, the area which is to be cleaned, should be vacuumed before scrubbing. Large debris, strings and wire must be removed to prevent being caught in brushes.

If the machine is allowed to stand in neutral with the scrub deck down for more than 2 seconds, the solutions flow stops and brush motor stops. When forward travel is resumed, the solution flow and the scrub brush motor will continue. Overlap the brush path and avoid transporting over previously cleaned areas.

RECOMMENDED SCRUBBING PATH

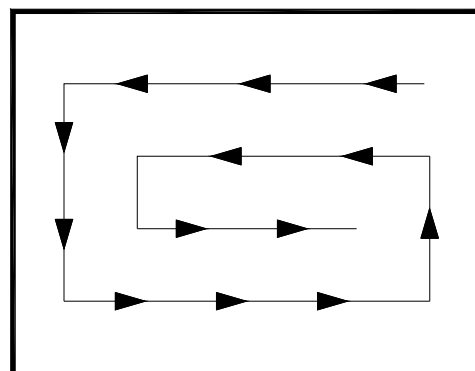

MACHINE OPERATION

TO BEGIN SCRUBBING

When operating the machine around people, pay close attention for unexpected movement. Use extra caution around children.

1. Turn machine power on.
2. Position rotary switch to the position matching the process to be performed, and the chemical that was added to the solution tank or chemical tank (Deluxe), either interim or interim/pre-spray (Deluxe) or extraction cleaning.
3. Check position of reverse button and the position speed control knob so that the machine is set to travel in the direction and the speed intended.
4. Drive machine forward to begin scrubbing.

TO STOP SCRUBBING

1. While scrubbing turn off the pump switch to stop spraying solution. Continue to scrub and recover the solution for an additional pass.
2. Allow the throttle switches to return to neutral.
3. Rotate the selector switch to the accessory position so that the vacuum motor continues to run and evacuate the system. This will also raise the deck and vacuum shoes.
4. Turn the rotary switch to the off position by rotating the selector switch clockwise. Turn machine power off.

DELUXE

1. While scrubbing turn off the pump switch to stop spraying solution. Continue to scrub and recover the solution for an additional pass.
2. Allow the throttle switches to return to neutral.
3. Rotate the selector switch to the accessory position so that the vacuum motor continues to run and evacuate the system. This will also raise the deck and vacuum shoes.
4. Turn the rotary switch to the off position by rotating the selector switch clockwise. Turn machine power off.

FOR SAFETY: Before leaving or servicing machine: stop on level surface, turn off machine and remove key.

FOR SAFETY: When using machine, go slow on inclines and slippery services.

MACHINE OPERATION

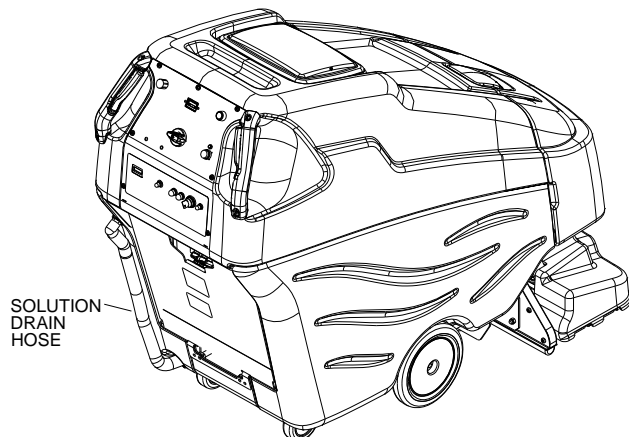

EMPTYING AND CLEANING SOLUTION TANK

1. Park the machine next to a floor drain. Drain hose is at the rear of the machine.
2. Turn the machine power off.
3. Remove the top of the hose from the barb mount and lower hose in direction of the drain. Do not stand in front of end of hose. Solution will come out with force.
4. Remove the front cover and solution fill cover.
5. Flush the solution tank out with clean water and run several gallons of clean water through both spray jet systems. Do not use water hotter than 140°F (60°C) to clean tank or damage may occur.
6. Replace the drain hose to the barbed fitting.
7. If machine is to be stored, leave the solution fill cover off.

EMPTYING AND CLEANING CHEMICAL TANKS AND SYSTEM (DELUXE)

1. Turn the machine power off.
2. Park the machine next to a floor drain. The tanks are located at the front of the machine.
3. Remove the cap and straw from each chemical bottle and install the closed caps.
4. Remove the tanks by lifting off the solution fill tower.
5. The chemical can remain in the tank or be disposed of properly. Remove one cap at a time and dispose of chemical. Rinse tanks with clean water.
6. Rinse the chemical system by putting the straws and caps in clean water. Push the prime/flush switch for 30 seconds in each direction, "A" and "B".

EMPTYING AND CLEANING RECOVERY TANK

1. Park the machine next to a floor drain. Drain hose is at the front of the machine.
2. Turn the machine power off.
3. Remove front cover. Remove hose assembly from mounting hook. Place the end of the hose at the drain and slowly remove the cap. Do not stand in front of hose end. Soiled solution will come out with force.
4. Remove dome lid.
5. Flush the recovery tank out with clean water. Do not use water hotter than 140°F (60°C) to clean tank or damage may occur.
6. Replace the drain hose cap and place hose back on hook. Replace front cover.
7. If machine is to be stored, leave the recovery dome off.

NOTES:

MACHINE OPERATION

SERVICE SCHEDULE

MAINTENANCE	BEFORE EACH WORK PERIOD	AFTER EACH WORK PERIOD	50 HRS	100 HRS	200 HRS
Check water level of batteries after charging; add distilled water if necessary.	*				
Check brushes for proper installation.	*				
Check for securely attached drain hose, plug and cap.					
Check that solution fill lid seals tightly	*				
Visually check for damaged or worn tires.	*				
Check all throttle, direction and speed controls for proper operation.	*				
Observe spray pattern and clean jets if necessary.	*				
Prime chemical system for 30 seconds for each chemical.	*				
Clean brushes and check wear.		*			
Clean underside of scrub deck.		*			
Clean out solution tank.		*			
Clean out recovery tank.		*			
Clean and inspect solution filter strainer.		*			
Store with solution fill lid and recovery dome off tanks to allow tanks to dry.		*			
Clean outside of tank, check for damage.		*			
Flush chemical system		*			
Charge batteries.		*			
Clean off top of batteries.			*		
Check battery cells with hydrometer.			*		
Check battery connections are tight.			*		
Clean battery cases and battery compartment.				*	
Grease appropriate zerks (grease fittings).				*	
Clean pivot points on scrub deck.					*
Check all motors for carbon brush wear.					*
Check motor commutators.					*

MAINTENANCE-BATTERIES

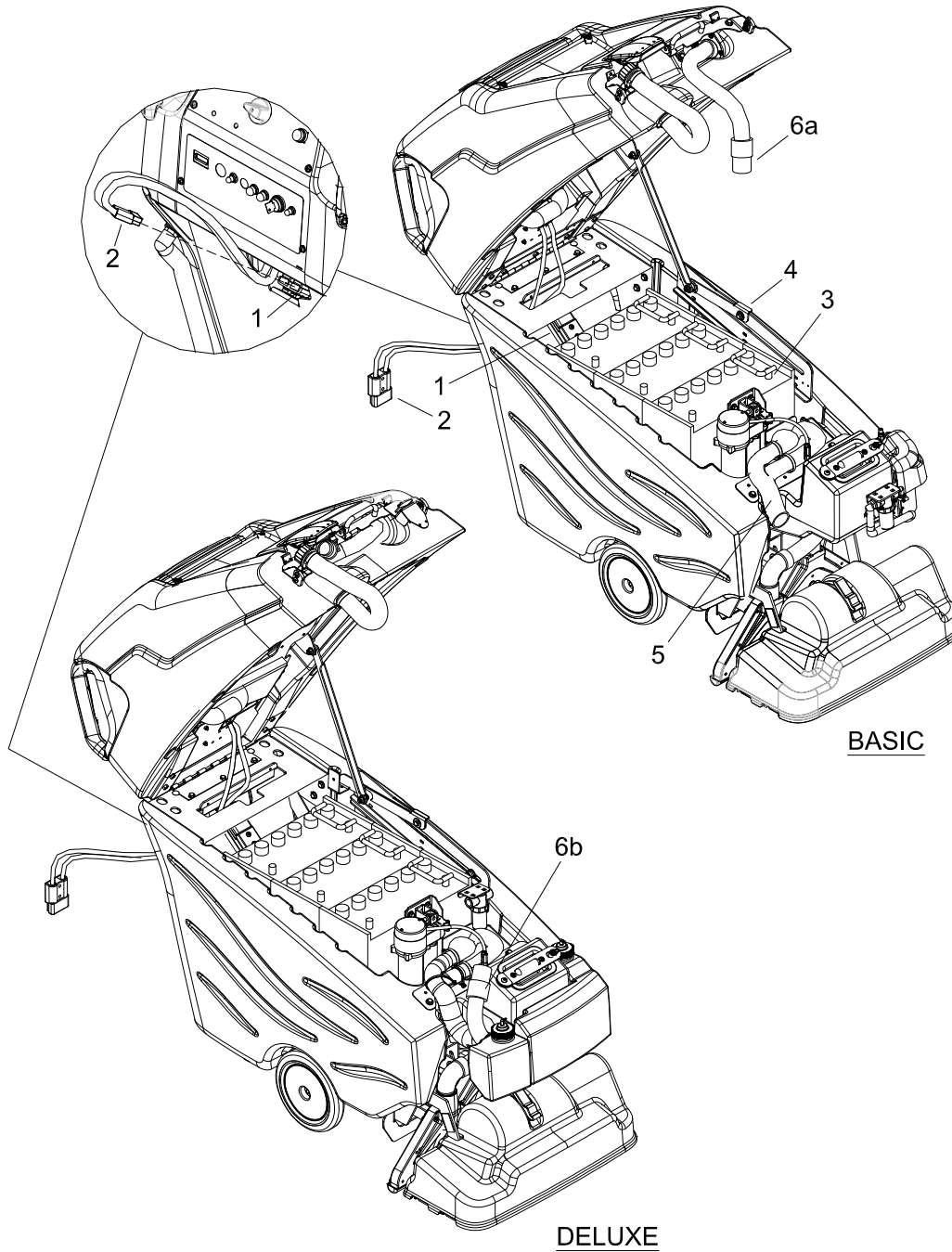

- 1. Battery Connector
- 2. Battery Connector
- 3. Batteries
- 4. Prop Rod and Catch

- 5. "Y" Tube
- 6a. Recovery Hose - Basic
- 6b. Recovery Hose - Deluxe

MAINTENANCE-BATTERIES

BATTERIES

The batteries provide the power to operate the machine. The batteries require regular maintenance to keep them operating at peak efficiency.

The machine batteries will hold their charge for long periods of time, but they can only be charged a certain number of times. To get the greatest life from the batteries, charge them when their charge level reaches 25% of a full charge. Use a hydrometer to check the charge level.

Do not allow the batteries to remain in a discharged condition for any length of time. Never expose a discharged battery to temperatures below freezing. Discharged batteries will freeze causing cracked cases. Do not operate the machine if the batteries are in poor condition or if they have a charge level below 25% (specific gravity below 1.155).

Keep all metallic objects off the top of the batteries, as they may cause a short circuit. Replace worn or damaged cables and terminals.

Check the electrolyte level in each battery cell before and after charging the batteries. Never add acid to the batteries, use distilled water. Do not allow water level to fall below the battery plates. Portions of plates exposed to air will be destroyed. Do not overfill. Keep plugs firmly in place at all times.

⚠ CAUTION: When servicing machine, avoid contact with battery acid.

⚠ WARNING: Batteries emit hydrogen gas. Explosion or fire can result. Keep sparks and open flame away. Keep covers open when charging.

⚠ WARNING: Wear eye protection and protective clothing when working with batteries.

⚠ WARNING: Charge batteries in a well ventilated area.

BATTERY MAINTENANCE

1. When cleaning the batteries, use a solution of baking soda and water. Do not allow the cleaning fluid to enter the battery cells, electrolyte will be neutralized.
2. Maintain the proper electrolyte level in each battery cell. If a cell should accidentally overflow, clean immediately.
3. Wipe off the top of the batteries at least once a week.
4. Test battery condition with a hydrometer at least once a week.
5. Ensure that all connections are tight and all corrosion removed.
6. Every 4 to 6 months, remove that batteries from the machine and clean the battery cases and battery compartment.

MAINTENANCE-BATTERIES

CHECKING BATTERY SPECIFIC GRAVITY

Use a hydrometer to check the battery specific gravity.

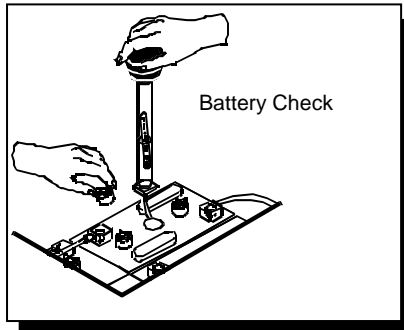

CHECKING GRAVITY

- A. Hydrometer
- B. Battery

NOTE: Do not take readings immediately after adding distilled water, if the water and acid are not thoroughly mixed, the reading may not be accurate.

Check the hydrometer readings against this chart.

SPECIFIC GRAVITY @ 80° F (27°C)	BATTERY CONDITION
1.265	100% CHARGED
1.225	75% CHARGED
1.190	50% CHARGED
1.155	25% CHARGED
1.120	DISCHARGED

NOTE: If the readings are taken when the battery electrolyte is any temperature other than 80° F (27°C), the reading must be temperature corrected.

To find the corrected specific gravity reading when the temperature of the battery electrolyte is other than 80° F (27°): Add (+) to the specific gravity reading 0.004 (4 points), for each 10° F (6° C) above 80° (27° C).

Subtract (-) from the specific reading 0.004 (4 points), for each 10° F (6° C) below 80° F (27° C).

CHARGING BATTERIES

⚠ WARNING:

When servicing machine, avoid contact with battery acid.

⚠ WARNING:

Batteries emit hydrogen gas. Explosion or fire can result. Keep sparks and open flame away. Keep covers open when charging.

⚠ WARNING:

Wear eye protection and protective clothing when working with batteries.

⚠ WARNING:

Charge batteries in a well ventilated area.

Use a 36 volt, 20 amp maximum output DC charger which will automatically shut off when the batteries are fully charged.

1. Empty recovery tank.
2. Stop the machine in a clean, well ventilated area next to the charger.
3. Turn "OFF" machine.

FOR SAFETY: Before leaving or servicing machine; stop on level surface, turn off machine and remove key.

4. Unplug the machine from the battery pack. Remove front cover. Disconnect recovery hose from "Y" tube. Raise recovery tank and verify prop rod latch is safely engaged.

⚠ WARNING:

Batteries emit hydrogen gas. Explosion or fire can result. Keep sparks and open flame away. Keep covers open when charging.

5. Check the electrolyte level in each battery cell. Before charging, add just enough distilled water to cover the plates. After charging is complete, add just enough distilled water to bring up the level to the indicator ring. If the water level is too high before charging, normal expansion rate of the electrolyte may cause an overflow resulting in a loss of battery acid balance and damage the machine.

MAINTENANCE-BATTERIES

6. Replace the battery caps, and leave them in place while charging.
7. Unplug the machine connector from the battery.

FOR SAFETY: When charging, connect the charger to the batteries before connecting the charger to the AC wall outlet. Never connect the charger to the AC wall outlet first. Hazardous sparks may result.

8. Plug the charger connector into the battery connector. Connect the charger AC plug to a wall outlet. The charger gauge should indicate that the batteries are charging.
9. When the batteries are fully charged, disconnect the charger from the AC wall outlet, then disconnect the charger from the batteries.
10. Connect the machine to the battery connector.
11. Check the electrolyte level. It should be up to the indicator ring. If necessary, add distilled water.
12. Lower recovery tank by safely disengaging the prop rod latch and slowly lowering. Replace the hose and "Y" tube connection. Replace front cover.

CHANGING BATTERIES

Stop the machine in a clean area next to the charger. Turn off machine.

FOR SAFETY: Before leaving or servicing the machine; stop on level surface, turn off machine and remove key.

1. Disconnect machine from battery pack.
2. Raise recovery tank and engage prop rod latch.
3. Disconnect main positive lead and secure cable terminals away from batteries.
4. Loosen both terminals on each jumper cable and remove one at a time.
5. Prepare a suitable site to place the batteries.
6. Attach suitable battery lifting device and lift batteries from the machine.

⚠ WARNING:

Batteries are a potential environmental hazard. Consult your battery supplier for safe disposal methods.

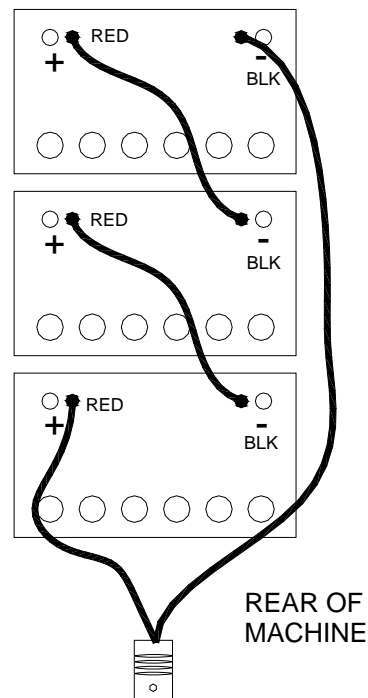

MAINTENANCE-SCRUB DECK

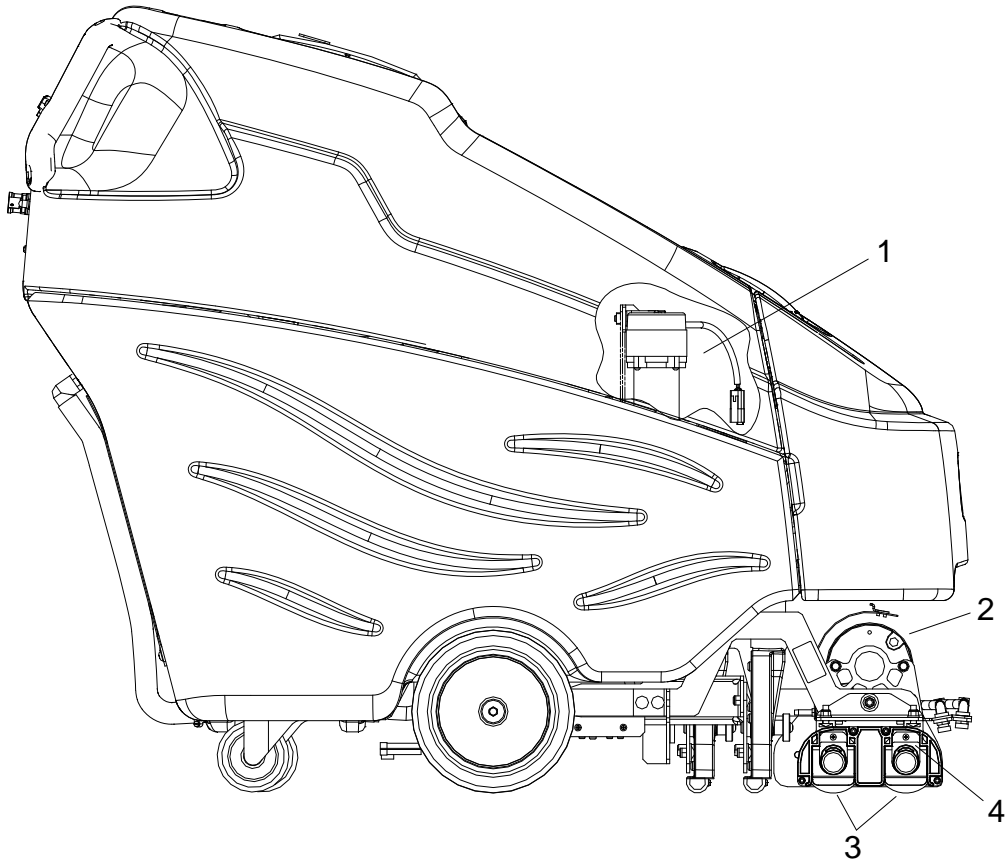

-
1. *Scrub Deck Lift Actuator*
 2. *Scrub Brush Motor*

3. *Scrub Brushes*
4. *Retaining Clip*

MAINTENANCE-SCRUB DECK

SCRUB HEAD

The dual cylindrical scrub head is designed to scrub chemical into the carpet. The two counter rotating brushes raise the pile of the carpet, giving it a lush groomed appearance.

MAINTENANCE

Scrub brushes should be exchanged front to back every 50 hours to ensure even wear. Scrub brushes should be replaced as a set when bristle length wears to height of yellow Perform Alert™ bristles.

SCRUB BRUSH REMOVAL

The scrub brushes are removed from the right side of the machine.

1. Raise the scrub deck to the storage position.
2. Pull out on the bottom of the retaining clip.
3. The brush assembly and end cap should drop down. Then pull the brush down far enough to clear the bottom of the housing.
4. Pull brush out with a rocking motion to free brush from drive hub.

SCRUB BRUSH REPLACEMENT

1. Lift the drive side of the brush and push it onto drive hub until a positive stop is felt. The brush cannot be installed until the brush is fully seated on the drive hub.
2. Pull out on the bottom of the retaining clip.
3. Line up the end cap with the flats to each side.
4. Slide brush up into the retaining clip until it clicks in place.

MAINTENANCE-SCRUB DECK

⚠ WARNING: Do not use a pressure washer to clean around the brush motors. Use tap pressure only.

TO REPLACE SCRUB BRUSH MOTORS

1. With the scrub deck in the lowered position, remove the deck cover and disconnect brush motor wiring connector from harness.
2. Remove the motor and end bracket assembly from the deck.
3. Separate brush motor from end brackets.
4. Reverse to reassemble.

BRUSH MOTOR CARBON BRUSH REPLACEMENT

1. Scribe alignment mark on motor barrel to motor cap. Remove two bolts.
2. Remove end cap from motor.
NOTE: Motors contain two wave washers in cap. Do not lose these.
3. Release brush from spring tension. Remove screw connecting brush wire lead to brush holder. Clean brush holder to insure free movement.
4. Retract spring and install new brush. Install connector screw and lead.
5. When all new brushes are installed. Place all in retracted position, held into brush holder by spring tension.
6. Carefully place end cap onto bearing on motor shaft.
NOTE: Use care to assure wave washer alignment.
7. With end cap in partially installed position, release all brushes to contact position with motor commutator.
NOTE: Failure to insure all brushes are released will result in motor failure.
8. Reset end cap and realign with scribe marks on motor barrel. Reinstall the two attach bolts from cap into base.
9. Maintain alignment between motor barrel base and cap.

MAINTENANCE-SCRUB DECK

ACTUATOR SCRUB DECK REMOVAL/REPLACEMENT

FOR SAFETY: Before leaving or servicing machine, stop on a level surface. Turn off machine.

1. Lower scrub deck. Remove the front cover and raise recovery tank.
2. Disconnect electrical connector.
3. Remove the clevis pin retaining the bottom of the actuator.
4. Remove the clevis pin retaining the top of the actuator.
5. Reverse for re-installation.

SCRUB DECK ACTUATOR ADJUSTMENT

The actuator will need to be adjusted when replaced.

To adjust the actuator:

1. While holding actuator barrel to prevent it from spinning, apply power to the actuator such that it is fully extended. Positive power to white wire, and negative/ground to black. Limit switch within actuator will stop it.
2. With actuator fully extended, attach to the top bracket.
3. At the bottom mount align the mounting hole with the center of the slot, turn the barrel in or out enough to align connection to bracket.
4. Connect actuator electrical plug.
5. Check travel of actuator during operation.

MAINTENANCE-SOLUTION STRAINER & PUMP - BASIC

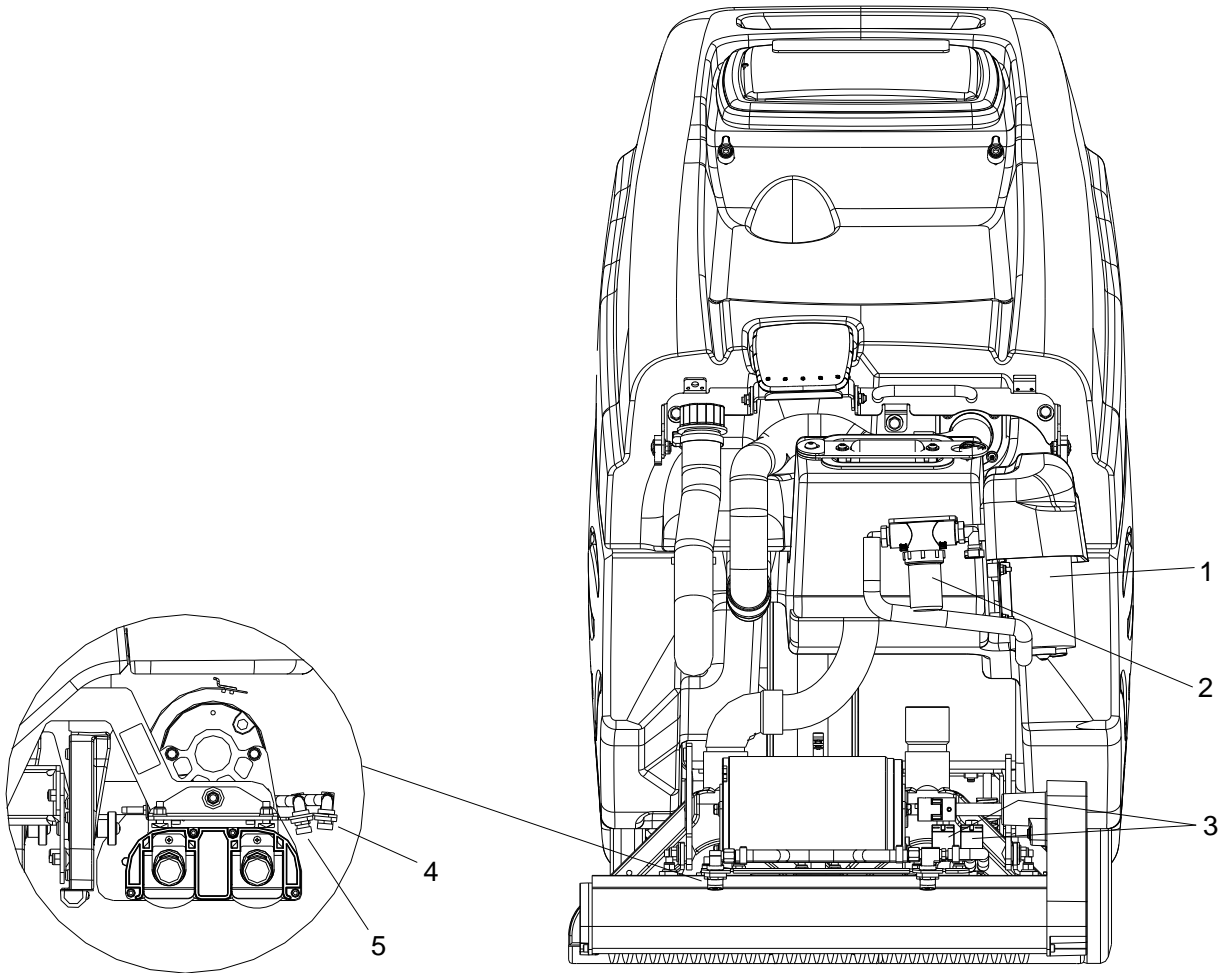

- 1. Pump
- 2. Solution Strainer

- 3. Solenoid Valves
- 4. Jets- Interim
- 5. Jets-Extraction

MAINTENANCE-SOLUTION STRAINER & PUMP - BASIC

1. SOLUTION STRAINER

The solution strainer is located on the front of the machine under the front cover. The strainer protects the pump, solenoid valve and jets from debris. If there is little or no solution flow to the ground, check the strainer for debris. Clean the solution strainer. To remove the strainer, turn the bottom part of the strainer counterclockwise until the bottom is separated. Clean out the debris from the wire mesh and the bowl and re-assemble. Make sure the O-ring gasket is in place when re-assembled.

2. PUMP

The pump is located on the front of the machine under the front cover. The pump delivers solution from the tank to the scrub deck.

To repair or replace pump:

1. Remove front cover.
2. Remove hoses connecting the pump.
3. Remove screws that secures pump to mounting plate.

3. SOLENOID VALVE

The solenoid valves are mounted on the front of the scrub deck, on left side.

The solenoid valves shuts off solution flow to jets whenever scrubbing stops or in reverse. To repair or replace solenoid valve, remove screws that secure it to deck.

4. JETS

The two sets of jets are located in front of the scrub deck.

The jets spray cleaning solution onto the carpet. The spray pattern should be checked regularly and if jets become clogged they should be cleaned or replaced immediately.

To clean jets:

1. Remove jet from jet body by rotating it counterclockwise.
2. Blow debris back through orifice if possible. Do not use pointed object to unplug jet. This will damage jet and cause improper spray pattern and solution flow through jets.
3. If jet cannot be cleaned by blowing debris back through its orifice, submerge jet in small container of acetic acid and let soak for up to six hours.
4. After soaking jet, use a soft brush to remove debris and rinse thoroughly.
5. Install jet in jet body by rotating it clockwise firmly into place.
6. For lower flow in extraction "B" other jets are available. (see Suggested Spare Parts).

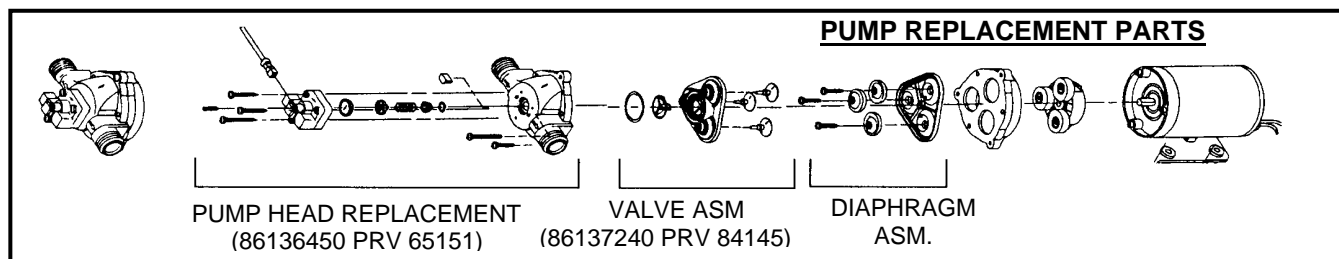

MAINTENANCE- SOLUTION STRAINER & PUMP - DELUXE

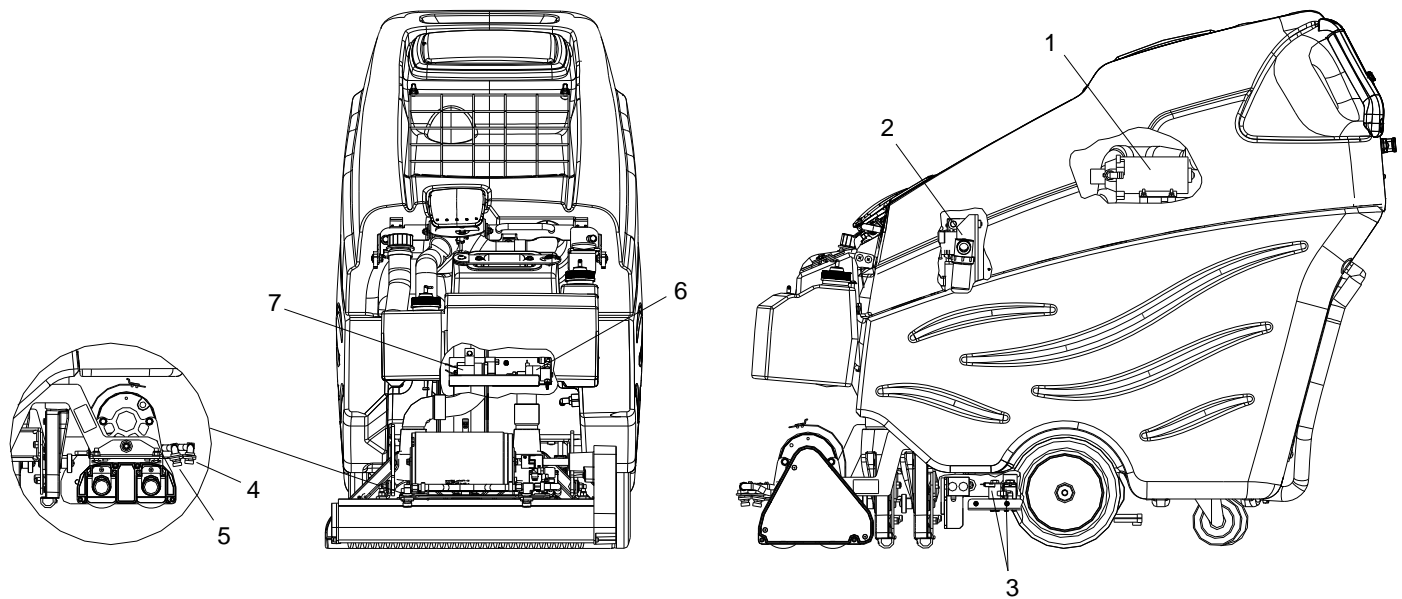

1. Pump
2. Solution Strainer
3. Solenoid Valves
4. Jets-Interim

5. Jets-Extraction
6. A-B Chemical Valve
7. Chemical Pump

MAINTENANCE-SOLUTION STRAINER & PUMP - DELUXE

1. SOLUTION STRAINER

The solution strainer is located under the recovery tank. The strainer protects the pump, solenoid valve and jets from debris. If there is little or no solution flow to the ground, check the strainer for debris. Clean the solution strainer. To remove the strainer, turn the bottom part of the strainer counterclockwise until the bottom is separated. Clean out the debris from the wire mesh and the bowl and re-assemble. Make sure the O-ring gasket is in place when re-assembled.

2. PUMP

The pump is located on underside of the recovery tank. The pump delivers solution from the tank to the scrub deck.

To repair or replace pump:

1. Remove bracket assembly from the bottom side of the recovery tank.
2. Remove hoses connecting the pump.
3. Remove screws that secures pump to mounting plate.

3. SOLENOID VALVE

The solenoid valves are mounted on the front of the scrub deck, on left side.

The solenoid valves shuts off solution flow to jets whenever scrubbing stops or in reverse. To repair or replace solenoid valve, remove screws that secure it to deck.

4. JETS

The two sets of jets are located in front of the scrub deck.

The jets spray cleaning solution onto the carpet. The spray pattern should be checked regularly and if jets become clogged they should be cleaned or replaced immediately.

To clean jets:

1. Remove jet from jet body by rotating it counterclockwise.
2. Blow debris back through orifice if possible. Do not use pointed object to unplug jet. This will damage jet and cause improper spray pattern and solution flow through jets.
3. If jet cannot be cleaned by blowing debris back through its orifice, submerge jet in small container of acetic acid and let soak for up to six hours.
4. After soaking jet, use a soft brush to remove debris and rinse thoroughly.
5. Install jet in jet body by rotating it clockwise firmly into place.
6. For lower flow in extraction "B" other jets are available. (See Accessories page).

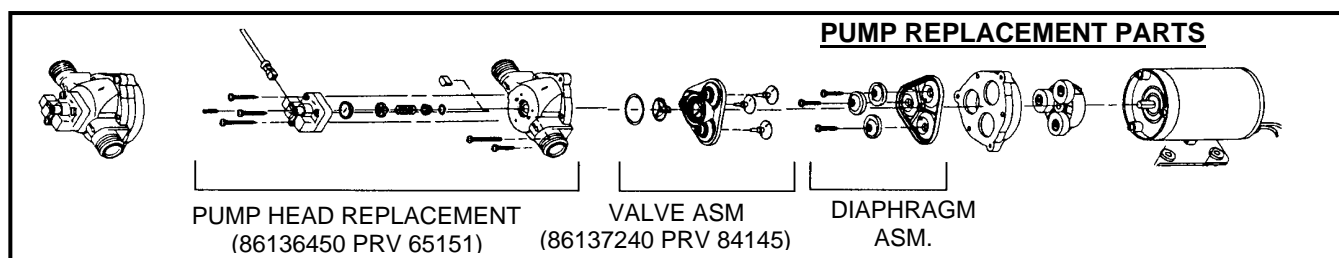

MAINTENANCE SOLUTION STRAINER & PUMP - DELUXE

5. A-B CHEMICAL PUMP & CHEMICAL PUMP

1. The chemical tank "A" holds either encapsulating interim chemical or pre-spray chemical. Tanks should be cleaned weekly. Extra chemical should be stored using the blank cap instead of the straw cap.
2. The chemical tank "B" hold the deep extraction chemical. The tank should be cleaned weekly. Extra chemical should be stored using the blank cap instead of the straw cap.
3. The chemical selector valve switches between the "A" and "B" chemical being pumped through the chemical mixing section and delivered to the solution system, depending on the position of the function switch on the control panel. The selector valve chemical pump, and chemical mixing section should be flushed with clean water after each use. Drain water through both the "A" and "B" cap and straws by putting them in water and pressing the "A" and "B" prime/flush switch each way for 30 seconds.

NOTES:

MAINTENANCE-DRIVE ASSEMBLY

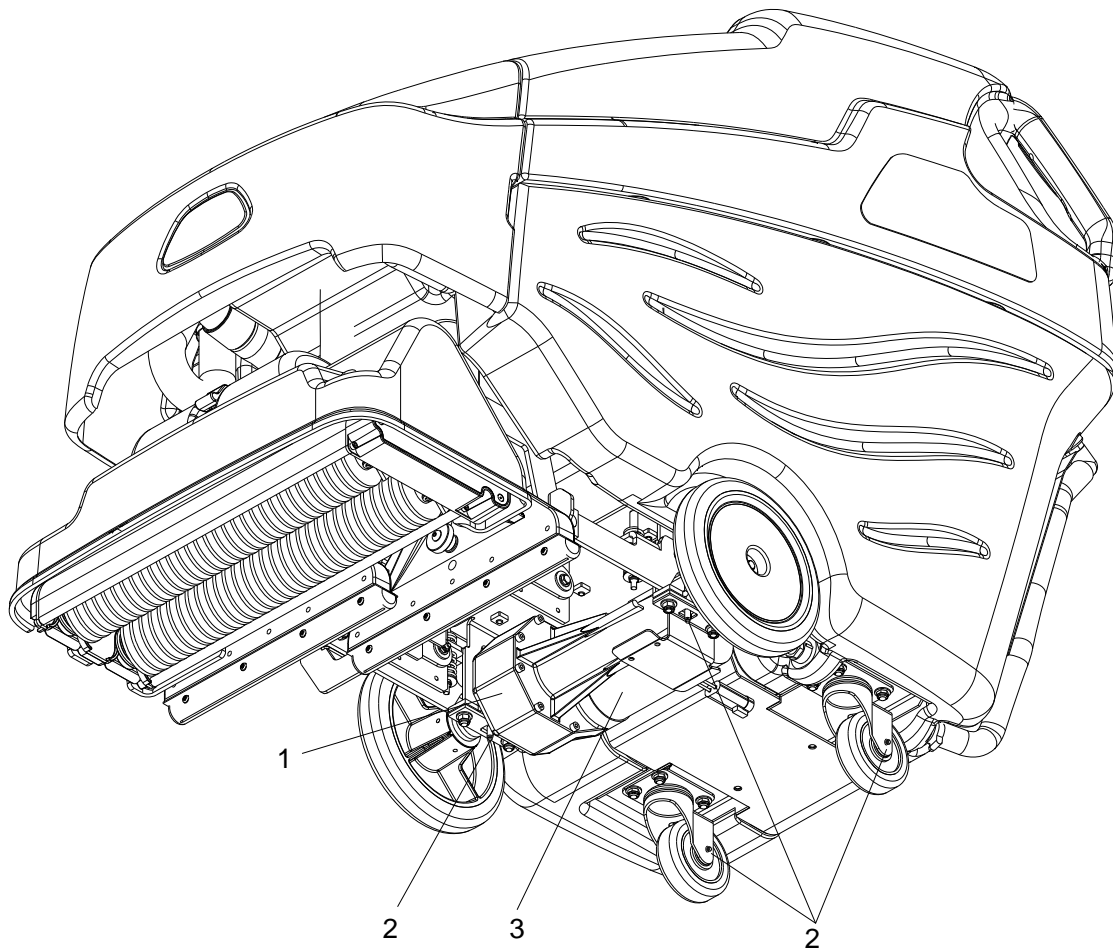

-
1. *Drive Assembly*
 2. *Grease Points*
 3. *Drive Motor*

MAINTENANCE- DRIVE ASSEMBLY

DRIVE MOTOR CARBON BRUSH REPLACEMENT



Do not use a pressure washer to clean around the motors. Use tap pressure only.

FOR SAFETY: Before leaving or servicing machine, stop on a level surface, turn off machine and remove key.

1. Disconnect batteries from machine.
2. Disconnect the electrical connection to the traction motor.
3. Remove brush cap.
4. Release brush from spring tension. Remove screw connecting brush wire lead to brush holder. Clean brush holder to insure free movement.
7. Install new brush and reinstall connecting screw and lead.
8. When all new brushes are installed. Place all in retracted position, held into brush holder by spring tension.
9. Carefully replace brush cap.

MAINTENANCE-VACUUM

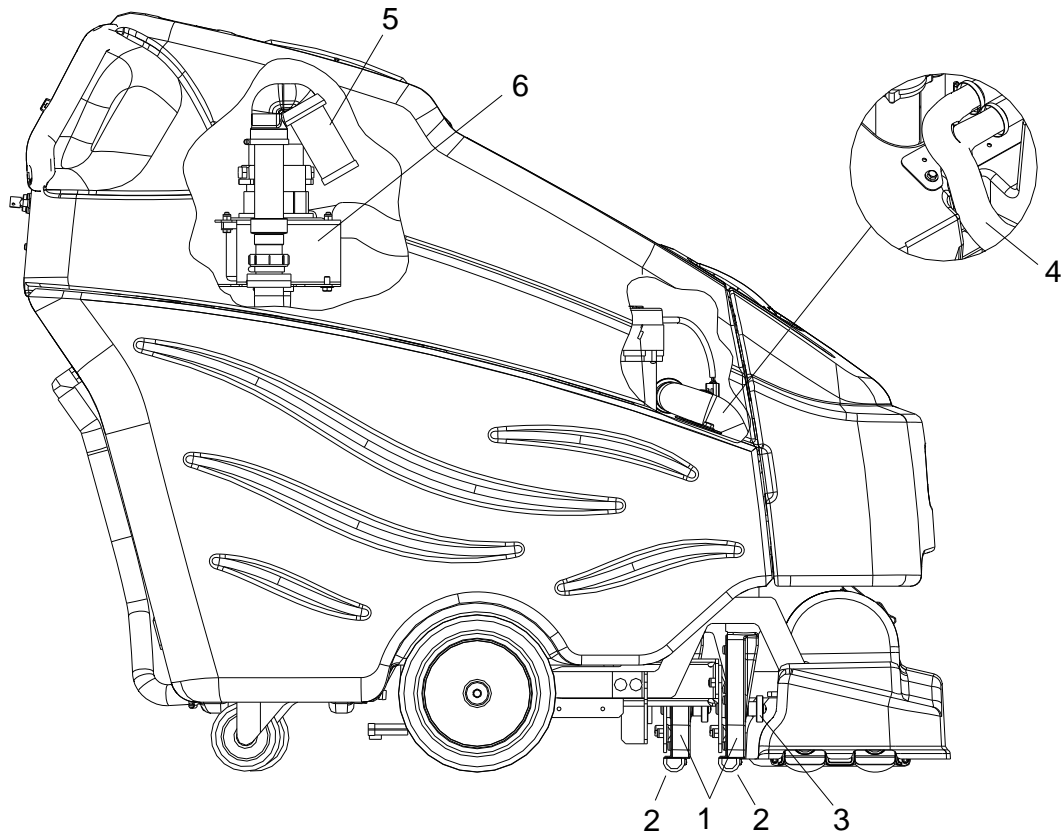

1. Vacuum Shoes
2. Vacuum Glides
3. Vacuum Shoe Retainer Knobs

4. "Y" Tube
5. Float Ball and Screen
6. Vacuum Motor

MAINTENANCE-VACUUM

VACUUM SHOES

The dual offset vacuum shoes are designed to extract soiled solution from the carpet. The plastic vacuum shoe glides minimize wear to flooring.

MAINTENANCE

The vacuum shoes should be removed and cleaned daily to ensure maximum recovery.

VACUUM SHOE REMOVAL

1. Unscrew retainer knob from right side vacuum shoe.
2. Pull vacuum shoe forward until it is free from pivot pin.
3. Remove vacuum hose from top of vacuum shoe
4. Repeat to remove left side vacuum shoe.
5. Inspect or repair as necessary and reinstall.

TO CLEAN VACUUM SHOES

1. With the vacuum shoes in the raised position, turn key switch "off".
2. Remove vacuum shoes.
3. Flush vacuum shoes from top with water. If necessary, clean blockage from narrow opening with a scraper or similar device.
4. Vacuum shoe glides may be removed for cleaning (or replaced) by removing the three pins that secure them to metal vacuum shoes.

RECOVERY TANK FLOAT SHUT-OFF

When water is no longer being vacuumed from the floor and the vacuum fan is operating, the ball float has engaged. The vacuum motors will not vacuum water with recovery tank full. The recovery tank must be drained.

1. The float shut-off screen can be cleaned in or out of the machine.
2. To clean the float shut-off while it is inside the machine wipe material off screen then rinse. Check that the ball is also clean and moves freely.
3. To remove the float shut-off, grasp the elbow with one hand tilt and pull the float screen assembly to pull it off the elbow.
4. To install, place one hand on the elbow, and then tilt and push the float screen assembly over the elbow.

MAINTENANCE-VACUUM

TO REPAIR OR REPLACE VACUUM MOTOR(S)

1. Remove the front cover, drain the recovery tank and disconnect the vacuum hose assembly from the "Y" tube.
2. Raise the recovery tank and safely engage the prop rod latch.
3. Disconnect electrical connector from the vacuum motor(s) and connecting hoses.
4. Unbolt the bracket and vacuum motor assembly and remove from tank.
5. Remove the vacuum motor from the bracket.
6. Reverse steps to install. Make sure the gaskets fit and seal properly as you reassemble.

Vacuum Motor Carbon Brushes

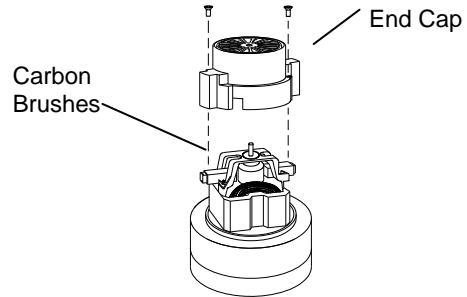

If armature commutator is grooved, extremely pitted or not concentric, the motor will need to be replaced or sent to a qualified service center.

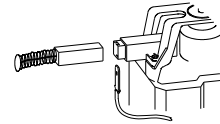

Important:

These brushes wear quicker as the length shortens due to increased heat. Spring inside brush housing will damage motor if brushes are allowed to wear away completely.

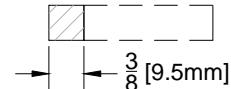

Periodically check the length of the carbon brushes. Replace both carbon brushes when either is less than 3/8" (9.5mm) long.

MAINTENANCE-TRANSPORTING

PUSHING MACHINE

The machine may be pushed for short distances at speeds not to exceed 5 mph. Be careful to avoid damaging machine. The machine may be pushed by hand from the rear.

NOTE: *To avoid damage caused by regenerative voltage, disconnect traction motor before towing or pushing machine.*

PREPARATION FOR LOADING /UNLOADING TRAILER

Before loading or unloading machine from trailer, remove vacuum shoes to eliminate interference. Scrub head must be in the up position before loading.

NOTE: *When transporting the machine on a trailer or in a truck, in addition to using tie-downs, be sure to block the tires to prevent the machine from rolling.*

MACHINE-TROUBLESHOOTING

PROBLEM	CAUSE	SOLUTION
No power to machine	Battery disconnected	Check all battery cable connections
	Battery cables corroded	Clean connections
	Faulty key switch	Replace switch
Little or no propel	Low battery charge	Charge batteries
	Machine turned on with propel trigger not in neutral position	Allow pedal to return to neutral. Restart
	Tripped circuit breaker	Reset circuit breaker and check brush
	Controller overheated	Allow cool down period
	Loose motor connection	Check wires and connections from controller to motor
	Faulty throttle circuit or potentiometer	Check wires and connections from throttle to controller and potentiometer resistance
	Faulty brake circuit	Check wires connections
Machine does not change speeds	Faulty speed control circuit or potentiometer	Check wires, connections and pot
Forward speed only Reverse speed only	Faulty forward/reverse switch	Replace switch
Poor scrubbing performance	Debris caught in scrub brushes	Remove debris
	Low scrub brush down pressure	Check brush wear
	Low battery charge	Charge batteries
Little or no solution flow to the floor	Solution tank empty	Fill solution tank
	Solution pump turned off	Turn on pump
	Solution strainer plugged	Clean solution strainer
	Solution system plumbing obstructed	Clear obstruction from plumbing
	Pump obstructed	Clean or replace pump
	Solution solenoid valve obstructed or stuck	Clean or replace valve
	Jet(s) obstructed	Clean or replace jet(s)
	Faulty pump circuit or pump	Check wiring, connections, and pump.
	Faulty solenoid	Check solenoid valve
Brush motors do not run, or run slowly	Circuit breaker(s) tripped	Reset circuit breaker(s) and check brush pressure.
	Low battery charge	Charge battery
	Fault brush circuit or motor	Check wires, connections and motor
	Worn brush motor brushes	Replace brushes, check commutator
Scrub deck will not go down/up	Actuator circuit breaker tripped	Reset breaker
	Faulty actuator circuit or actuator	Check wires, connections and actuator
No chemical flow (Deluxe)	Tank(s) empty	Fill with prime chemicals
	Chemical pump not primed	Prime chemical pump
	Chemical system obstruction	Rinse system with water

PARTS LIST

BRUSH DECK

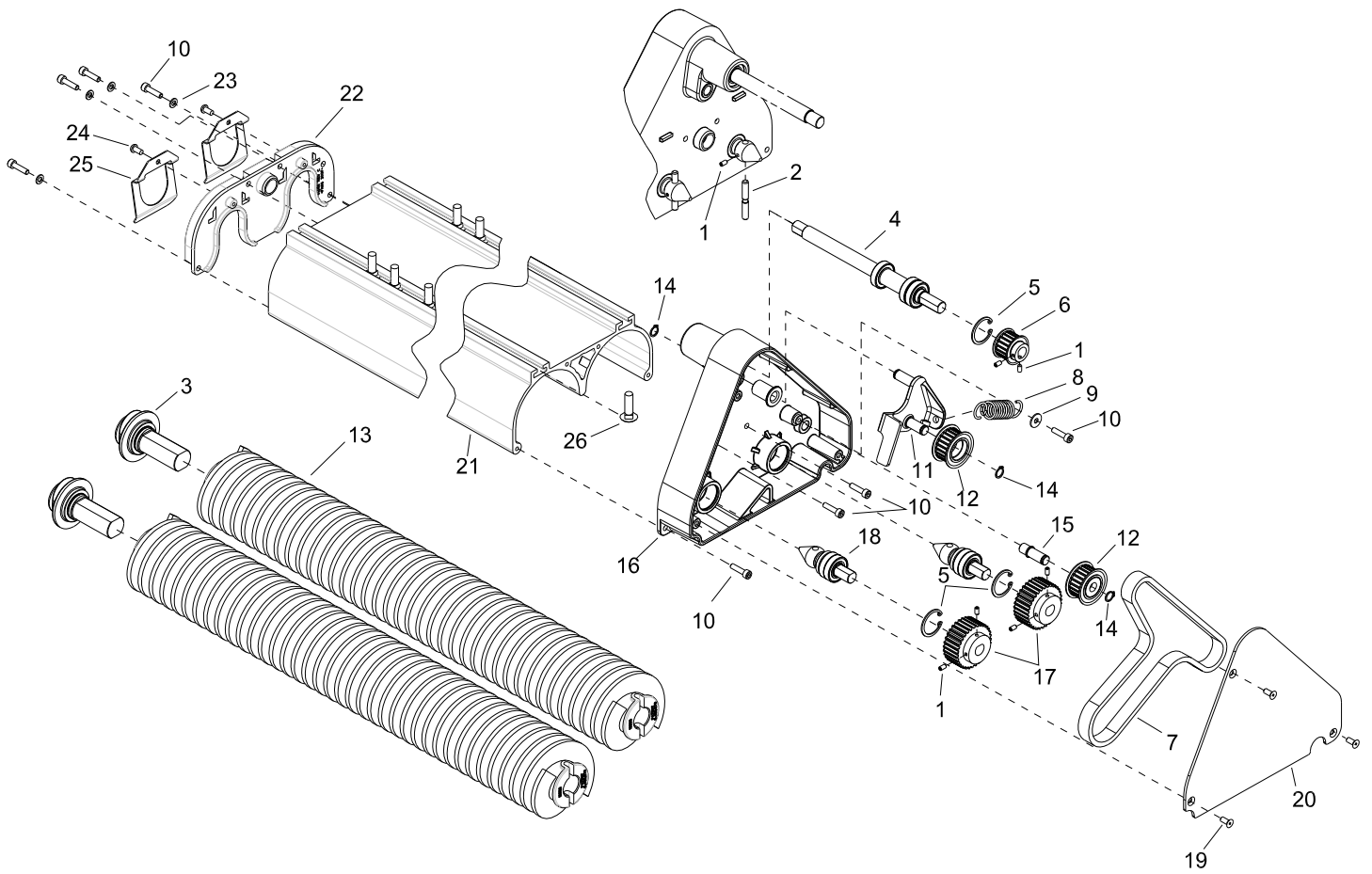

BRUSH DECK

REF	PART NO.	PRV NO.	QTY	DESCRIPTION	SERIAL NO. FROM	NOTES:
1	86223780	70896	8	SCR, M4X8, SET, ISO4029,CP,BLK		
2	86224170	730410	2	SHAFT, 6.2MM BRUSH DRIVE		
3	86012800	-	2	SHAFT ASM, BRUSH END CAP		
4	86012830	-	1	SHAFT ASM DRIVE 24"		
5	86223520	67598	3	RING, 28MM INT SNAP PHOSPHATE		
6	86223310	64116	1	PULLEY, 5MM HTD, 18T, 12.7 ID		
7	86215250	11049	1	BELT, 2S 5MM HTD, 15W, 128T		
8	86224660	730393	1	SPRING, TENSIONER		
9	86173330	87513	1	WASHER, M5 FLAT, ISO7093 SS		
10	86014990	-	4	SCR, M5X20, SHCS ISO4762, SS		
11	86215870	140914	1	BRKT, TENSIONER ARM		
12	86012780	-	2	PULLEY ASM, 5MM HTD 22T		
13	86230690	12532	2	BRUSH, EXTRACTOR 24"		
14	86223490	67468	3	RING, 10MM EXT SNAP, DIN 471		
15	86224130	730394	1	SHAFT, TENSIONER		
16	86219380	41546	1	HOUSING, BRUSH DRIVE		
17	86223320	64117	2	PULLEY, 32T, 5MM HTD		
18	86012790	-	2	SHAFT ASM, BRUSH DRIVE		
19	86172970	70911	3	SCR, M5X12, PHLP FHMS, ISO7046, SS		
20	86222870	620103	1	PLATE, BRUSH DRIVE COVER		
21	86217800	32060	1	EXTRUSION, DUAL BRUSH 24"		
22	86219390	41548	1	HOUSING, BRUSH CLIP		
23	86173350	87515	4	WASHER, M5, FLAT, ISO7089, SS		
24	86172980	70912	2	SCR, KA50X10, PT OHS, WN14112, PLTD		
25	86224630	730380	2	SPRING, BRUSH CLIP		
26	86277130	70795	10	SCR, 5/16-18 X 1.00 CARRIAGE SS		

BRUSH DECK ACTUATOR

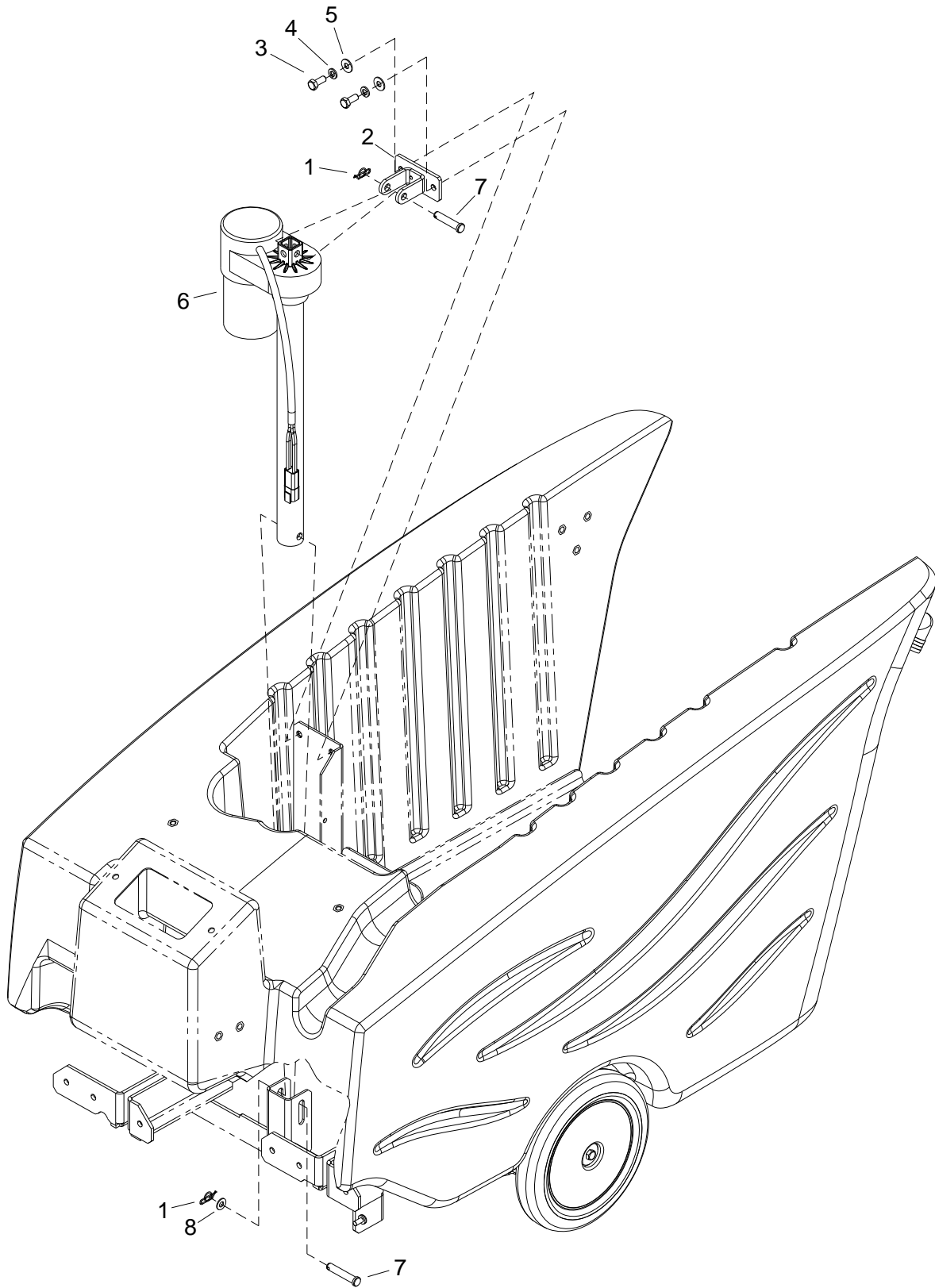

BRUSH DECK ACTUATOR

REF	PART NO.	PRV NO.	QTY	DESCRIPTION	SERIAL NO. FROM	NOTES:
1	86008670	80606	2	COTTER, 3/8" RING		
2	86091930	141037	1	BRKT, ACTUATOR MOUNT		
3	86276780	70728	2	SCR, 5/16-18 X 3/4 HHCS SS		
4	86279130	87083	2	WASHER, 5/16 SPLIT LOCK PLTD		
5	86010670	87029	2	WASHER, 5/16 FLAT SS		
6	86011800	-	1	ACTUATOR, 36VDC 2.75 STRK		
7	86248970	81406	2	PIN, CLEVIS 3/8 X 2.00 PLTD		
8	86278910	87003	1	WASHER, 3/8 ID X 7/8 OD SS		

BRUSH DECK MOTOR

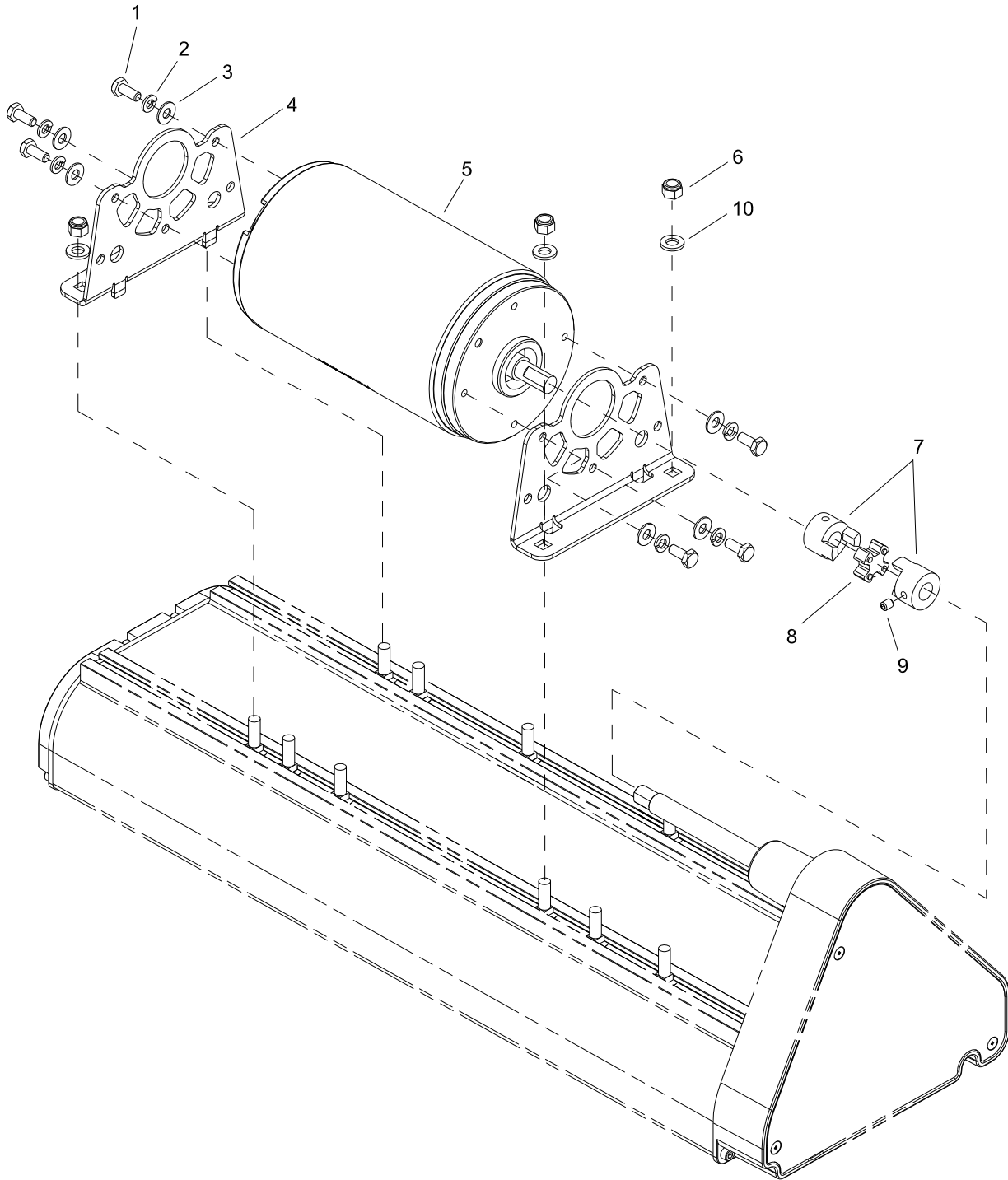

BRUSH DECK MOTOR

REF	PART NO.	PRV NO.	QTY	DESCRIPTION	SERIAL NO. FROM	NOTES:
1	86273750	70011	6	SCR, 1/4-20 X 5/8 HHCS SS		
2	86173340	87514	6	WASHER, SPLIT LOCK, 1/4 SS		
3	86010630	87013	6	WASHER, 1/4 ID X 5/8 OD SS		
4	86215880	140929	2	BRKT, MOTOR MOUNT		
5	86222130	53275	1	MOTOR, 36VDC		
6	86222290	57308	4	NUT, 5/16-18 HEX NYLOCK SS		
7	86217250	22105	2	COUPLER, 1/2" JAW		
8	86217260	22106	1	COUPLER, SPIDER		
9	86172960	70910	2	SCR, SET, M6X8, SH, ISO4029,SS		
10	86225790	87504	4	WASHER, 5/16 X .63 SS		

BRUSH DECK MOUNTING

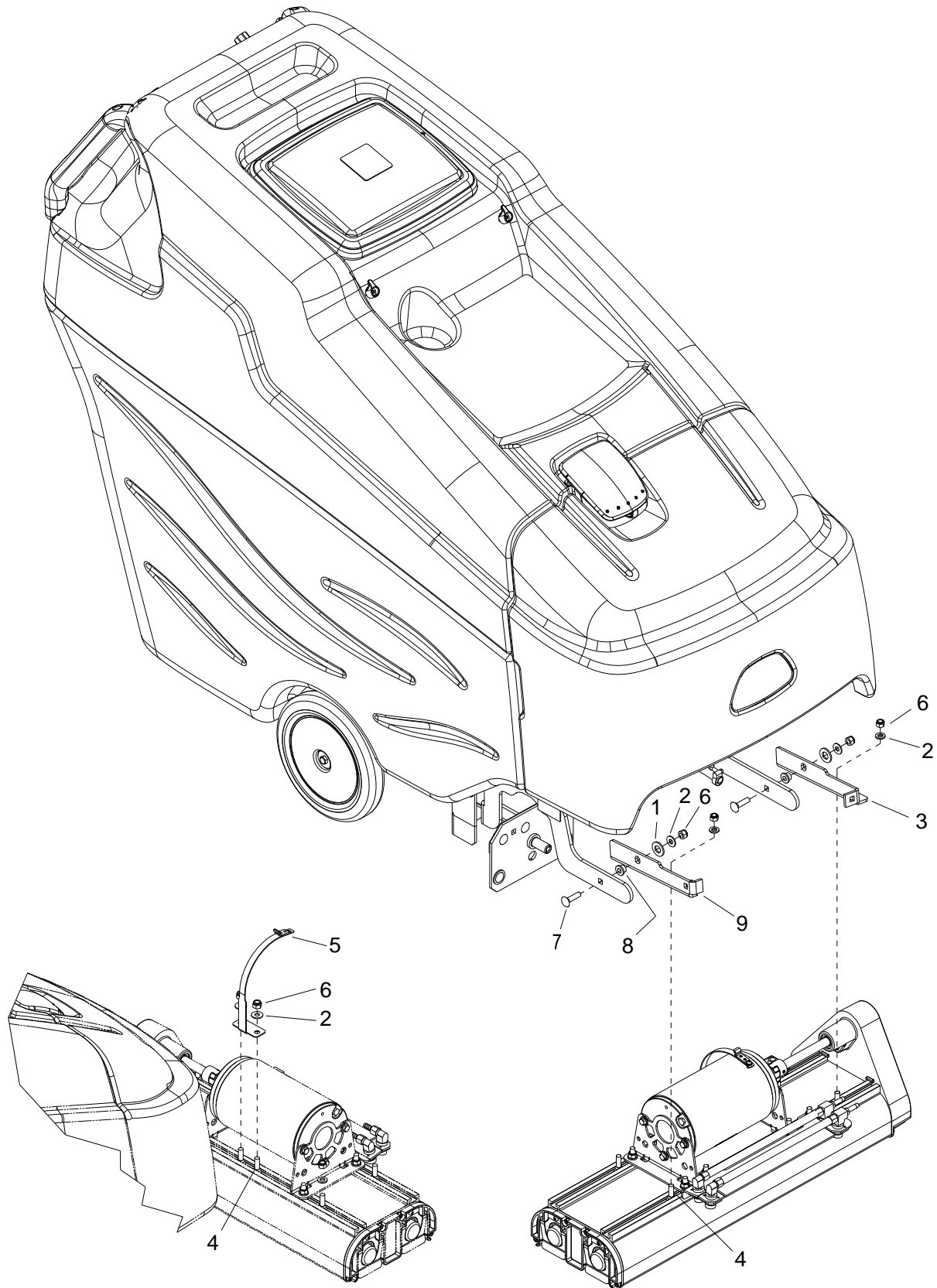

BRUSH DECK MOUNTING

REF	PART NO.	PRV NO.	QTY	DESCRIPTION	SERIAL NO. FROM	NOTES:
1	86259420	87232	2	WASHER, THRUST .51IDX1ODBRO		
2	86010670	87029	8	WASHER, 5/16 FLAT SS		
3	86295600	-	1	BRKT, BRUSH DECK PIVOT, LEFT		
4	86277130	70795	6	SCR, 5/16-18 X 1.00 CARRIAGE SS		
5	86088110	730443	1	STRAP, SHROUD LATCH		
6	86270830	57023	8	NUT, 5/16-18 HEX NYLOCK SS		
7	86277030	70780	2	SCR, 5/16-18 X 1.25 CARRIAGE SS		
8	86228990	09153	2	BEARING, FLNGD, .314IDX.502OD		
9	86295610	-	1	BRKT, BRUSH DECK PIVOT, R		

BRUSH DECK SHROUD

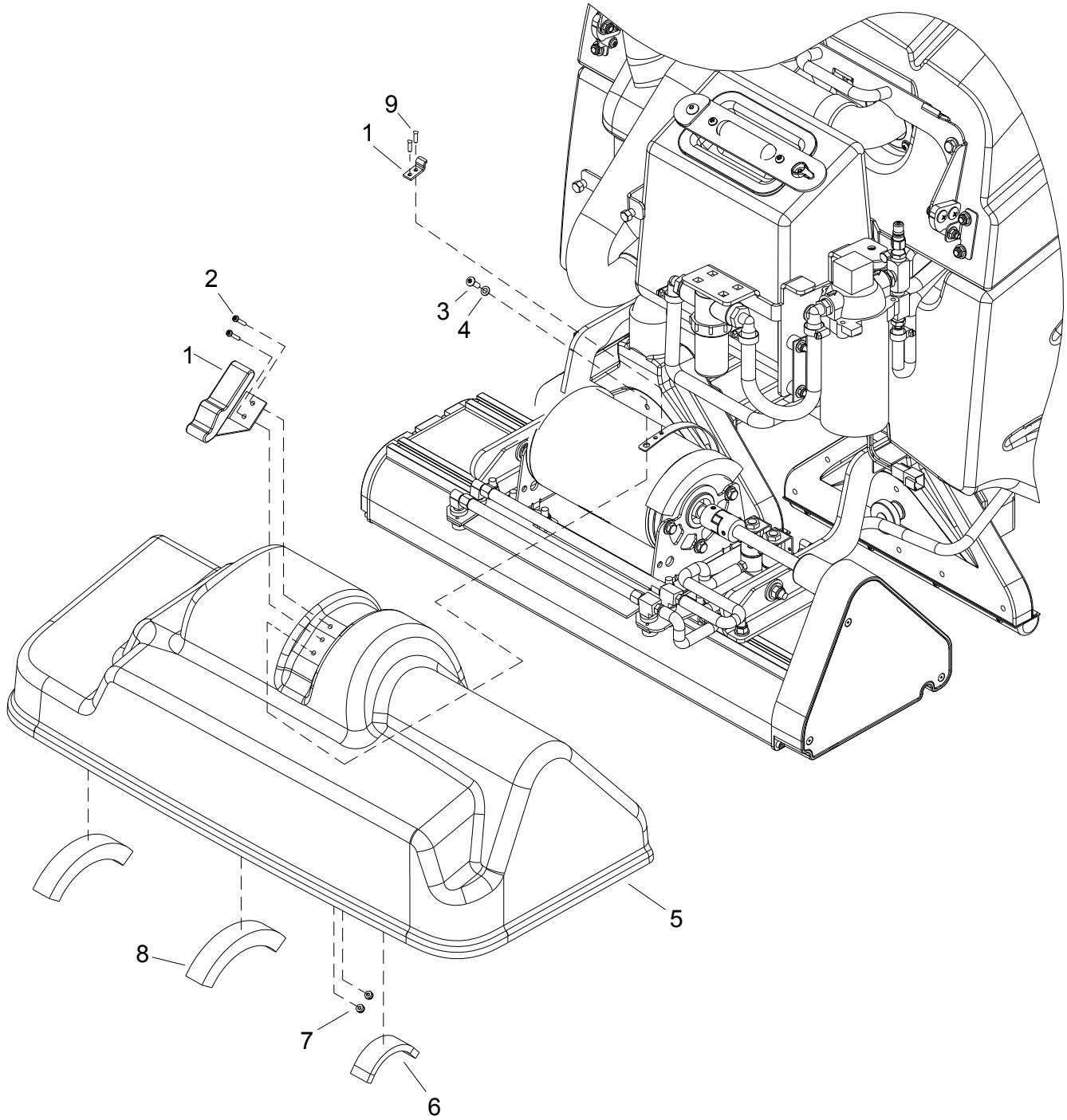

BRUSH DECK SHROUD

REF	PART NO.	PRV NO.	QTY	DESCRIPTION	SERIAL NO. FROM	NOTES:
1	86161800	46-802531	1	LATCH, CONCEALED KEEPER		
2	86273950	70056	2	SCR, 6-32 X 1/2 PPHMS SS		
3	86274520	70233	1	SCR, #10 X 3/8 PH HI-LO PLT		
4	86279190	87095	1	WASHER, #10 FLAT PLTD		
5	86059910	270167	1	COVER, DECK		
6	86012200	-	1	FOAM SPACER, SHROUD, 5/16 T		
7	86270920	57049	2	NUT, 6-32 HEX NYLOCK SS		
8	86012190	-	2	FOAM SPACER, SHROUD, 3/4 T		
9	86006400	67380	2	RIVET, 5.32 OF X 1/8 GRIP		

BRUSH DECK LIFT

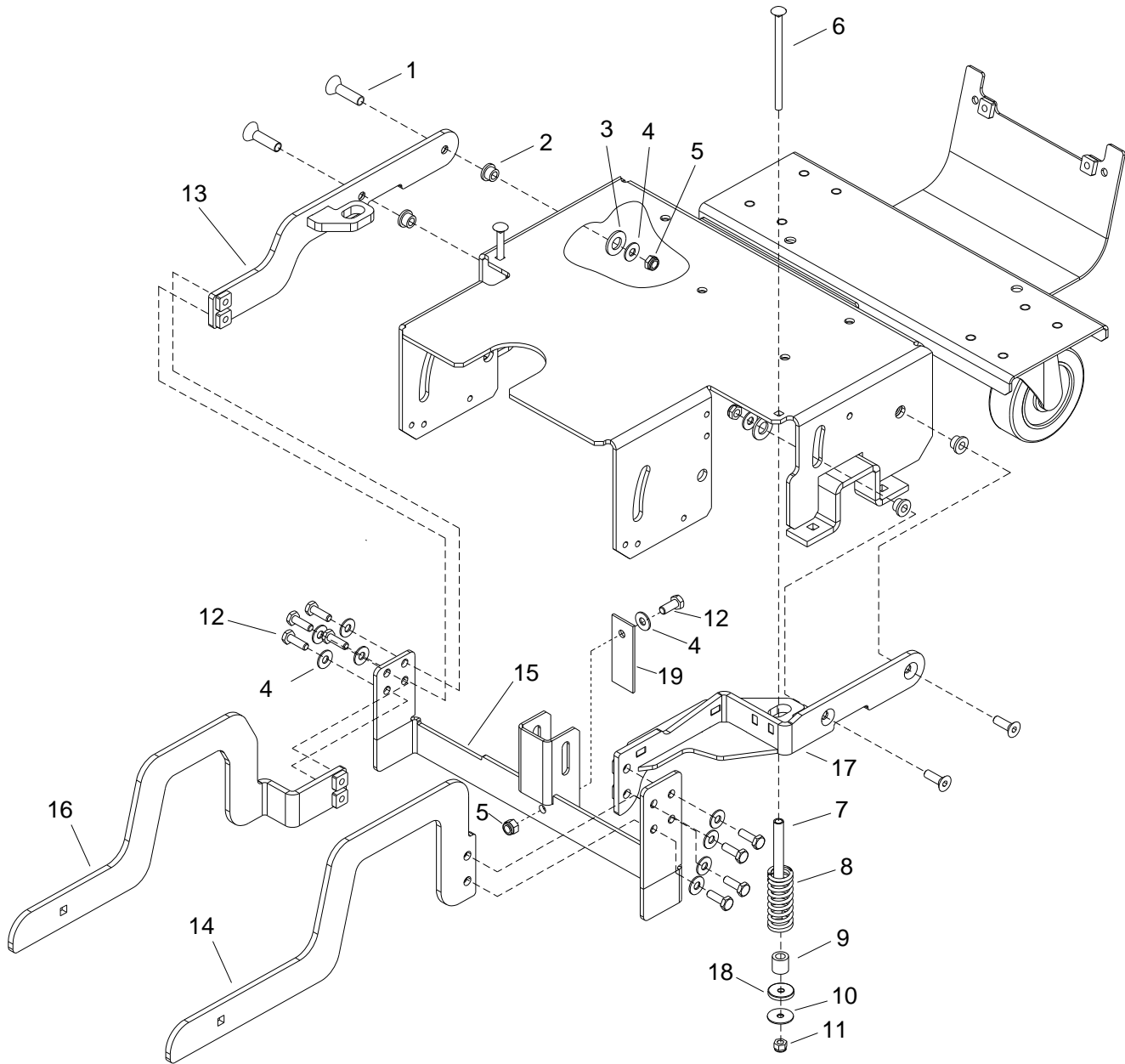

BRUSH DECK LIFT

REF	PART NO.	PRV NO.	QTY	DESCRIPTION	SERIAL NO. FROM	NOTES:
1	86290700	-	4	SCR, 5/16-18 X 1.0 FHCS SS		
2	86228990	09153	4	BEARING, FLNGD,.314ID X .502OD		
3	86259420	87232	4	WASHER, THRUST .51D X 1 ODBRO		
4	86010670	87029	13	WASHER, 5/16 FLAT SS		
5	86270830	57023	5	NUT, 5/16-18 HEX NYLOCK SS		
6	86012900	-	2	SCR, 1/4-20 X 4.5 CARRIAGE SS		
7	86088420	71154	4	SUPPORT, COUNTERBALANCE		
8	86013020	-	2	SPRING, COMP .97DX2.5LX.13W		
9	86231280	14400	2	BUSHING, .377IDX.627ODX.63		
10	86010810	87191	2	WASHER, 1/4 ID X 1.0 OD FLAT SS		
11	86271870	57290	2	NUT, 1/4-20 HEX NYLCK THIN SS		
12	86276780	70728	9	SCR, 5/16-18 X 3/4 HHCS SS		
13	86294810	-	1	ASSY, LIFT ARM, RIGHT, REAR		
14	86294580	-	1	LIFT ARM LEFT, FRONT		
15	86294800	-	1	BRKT, ACTUATOR LIFT		
16	86294560	-	1	LIFT ARM RIGHT, FRONT		
17	86294820	-	1	ASSY, LIFT ARM, LEFT, REAR		
18	86259400	87205	1	WASHER, THRUST.51ID X1 ODBRO		
19	86256130	730402	1	STRAP, STATIC, .2T X 1W X 3L		

CONTROL HANDLE

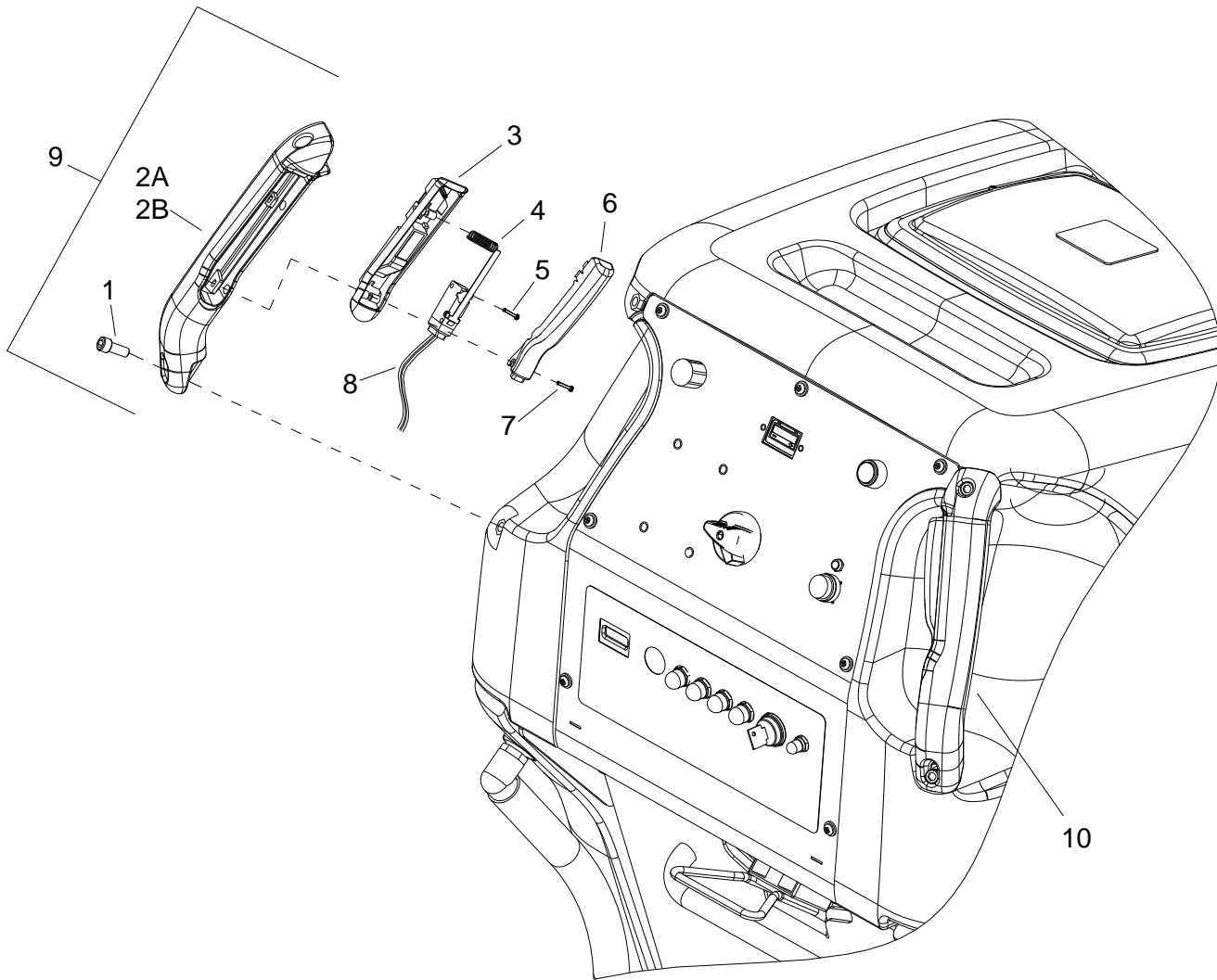

CONTROL HANDLE

REF	PART NO.	PRV NO.	QTY	DESCRIPTION	SERIAL NO. FROM	NOTES:
1	86277050	70782	4	SCR, 5/16-18 X 3/4 SHCS SS		
2A	86238730	38307	1	HANDLE, LEFT		
2B	86238740	38308	1	HANDLE, RIGHT		
3	86240990	41431	2	HOUSING, BUTTON		
4	86254920	730153	2	SPRING, COMP .24OD X 1.25X.018		
5	86277070	70784	2	SCR, 4-40 X 5/8 PPHMS		
6	86231480	140504	2	BUTTON, PROPEL		
7	86277060	70783	4	SCR, 8.32 X 7/8 PHTC TYPE 23		
8	86257230	730125	2	SWITCH, SPST MOM NO W/LEVER		
9	86004120	38312	-	PROPEL HANDLE ASM LEFT		
10	86004130	38313	-	PROPEL HANDLE ASM RIGHT		

CONTROL PANEL - LOWER - BASIC

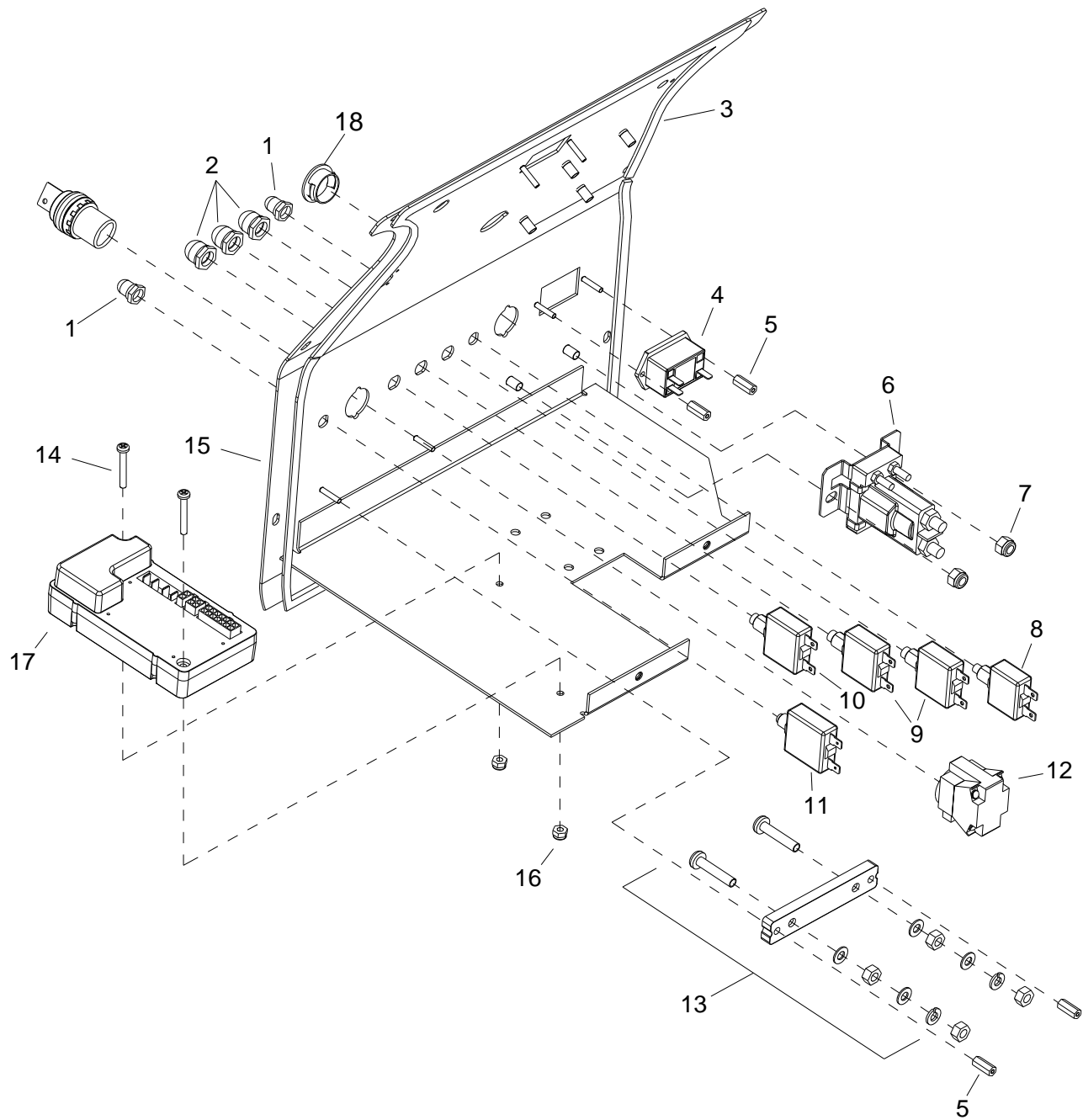

CONTROL PANEL - LOWER - BASIC

REF	PART NO.	PRV NO.	QTY	DESCRIPTION	SERIAL NO. FROM	NOTES:
1	86002010	14942	2	BOOT, 3/8 CIRCUIT BREAKER		
2	86008900	80845	3	BOOT, SEAL-PUSH BTN 7/16-28		
3	86237900	35278	3	GASKET, .125T X .37W X 23L		
4	86005530	54154	1	METER, 12-48 VDC LED HOUR		
5	86255900	73538	4	STANDOFF, 6-32 X 5/8 HEX NYL		
6	86251360	67166	1	RELAY, 36VDC 100A		
7	86005810	57245	2	NUT, 1/4-20 HEX NYLOCK SS		
8	86230080	141044	1	BRKR, 22AMP 250VAC, 50VDC		
9	86001910	14606	2	BRKR, 30A 50VDC CIRCUIT		
10	86001920	14607	1	BRKR, 25A 50VDC CIRCUIT		
11	86002000	14717	1	BRKR, 3 AMP 1681-090-300		
12	86007190	72161	1	SWITCH KEY DPST		
13	86229770	140805	1	BLOCK, SHUNT MOUNT		
14	86273880	70030	2	SCR, 8-32 X 1.25 PPHMS		
15	86295670	-	1	PANEL, CONTROL		
16	86270850	57026	2	NUT, 8-32 HEX NYLOCK		
17	86012910	-	1	CONTROLLER, I DRIVE		
18	86250160	66321	1	PLUG, .875"		

CONTROL PANEL – LOWER – DELUXE

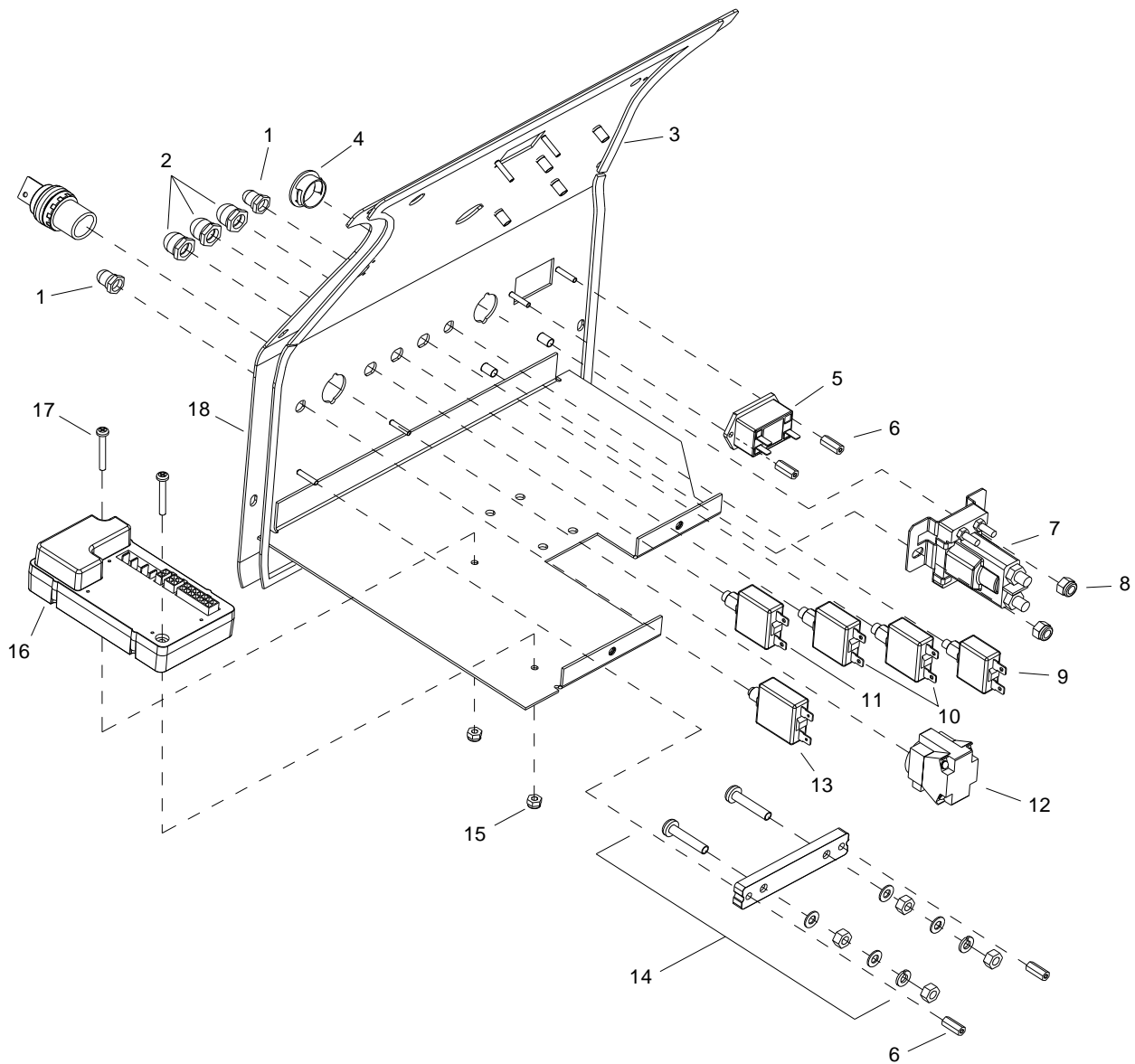

CONTROL PANEL - LOWER - DELUXE

REF	PART NO.	PRV NO.	QTY	DESCRIPTION	SERIAL NO. FROM	NOTES:
1	86002010	14942	2	BOOT, 3/8 CIRCUIT BREAKER		
2	86008900	80845	3	BOOT, SEAL-PUSH BTN 7/16-28		
3	86237900	35278	3	GASKET, .125T X .37W X 23L		
4	86250160	66321	1	PLUG, .875"		
5	86005530	54154	1	METER, 12-48 VDC LED HOUR		
6	86255900	73538	4	STANDOFF, 6-32 X 5/8 HEX NYL		
7	86251360	67166	1	RELAY, 36VDC 100A		
8	86005810	57245	2	NUT, 1/4-20 HEX NYLOCK SS		
9	86230080	141044	1	BREAKER, 22A 250VAC, 50VDC		
10	86001910	14606	2	BREAKER, 30A 50VDC CIRCUIT		
11	86001920	14607	1	BREAKER, 25A 50VDC CIRCUIT		
12	86007190	72161	1	SWITCH KEY DPST		
13	86002000	14717	1	BREAKER, 3 AMP		
14	86229770	140805	1	BLOCK, SHUNT MOUNT		
15	86270850	57026	2	NUT, 8-32 HEX NYLOCK		
16	86012910	-	1	CONTROLLER, I DRIVE		
17	86273880	70030	2	SCR, 8-32 X 1/25 PPHMS		
18	86295670	-	1	PANEL, CONTROL		
19	86296100	-	1	ASM, DC CONVERTER		

CONTROL PANEL - UPPER - BASIC

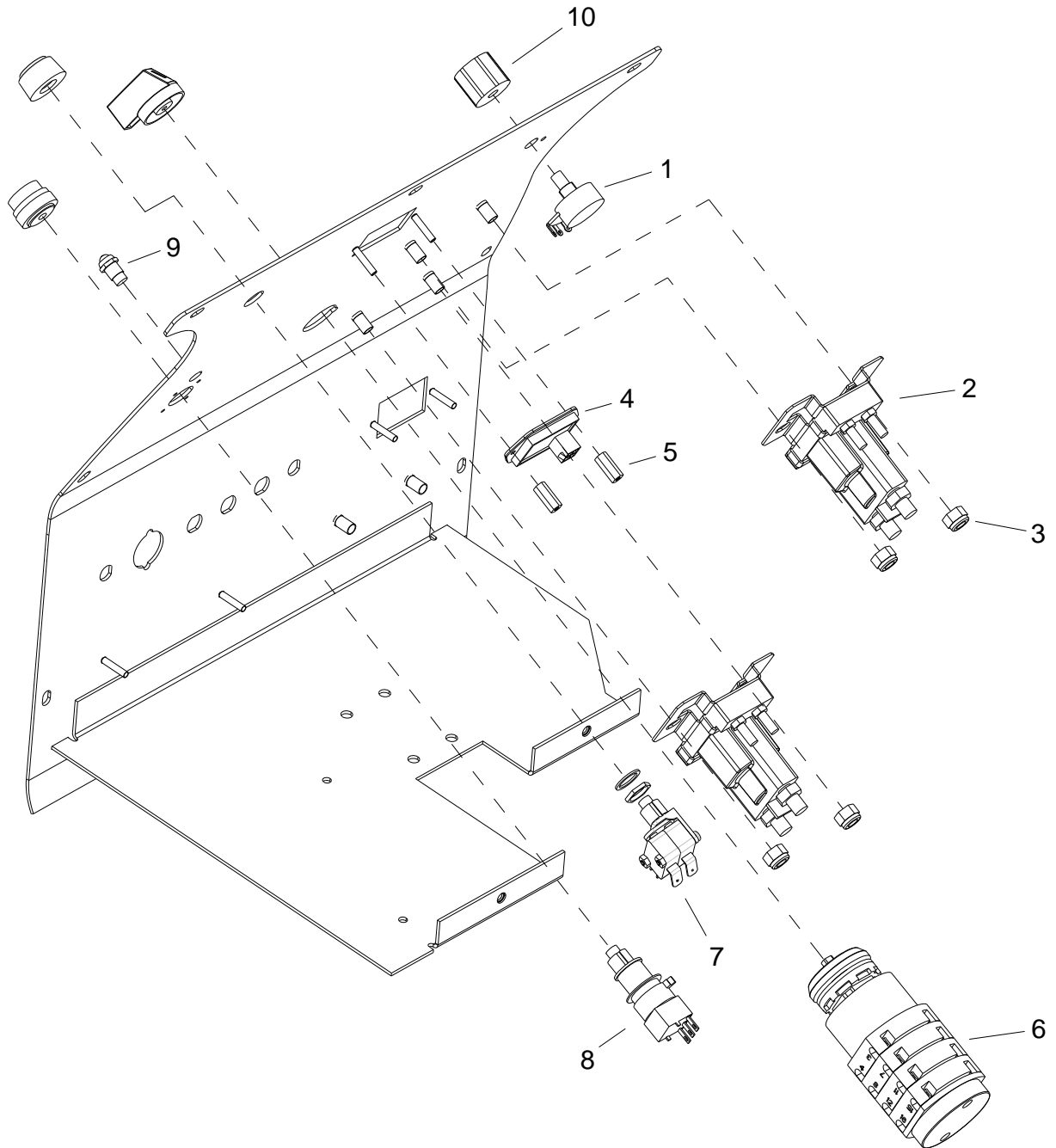

CONTROL PANEL - UPPER - BASIC

REF	PART NO.	PRV NO.	QTY	DESCRIPTION	SERIAL NO. FROM	NOTES:
1	86250280	66135	1	POTENTIOMETER 5K OHMS		
2	86251360	67166	2	RELAY, 36VDC 100A		
3	86005810	57245	4	NUT, 1/4-20 HEX NYLOCK SS		
4	86012670	-	1	METER, BATTERY, PG TRUE CHG		
5	86255900	73538	2	STANDOFF, 6-32 X 5/8 HEX NYL		
6	86014690	-	1	SWITCH, ROTARY CAM, 4 POS		
7	86257180	72207	1	SWITCH, MOMEMTARY, DPDT, WHITE		
8	86257150	72197	1	SWITCH, SPDT P-BUTTON		
9	86026010	82522	1	LIGHT ASM, INDICATOR		
10	86242110	48088	1	KNOB, .90 OD X .25 COLLET		

CONTROL PANEL – UPPER - DELUXE

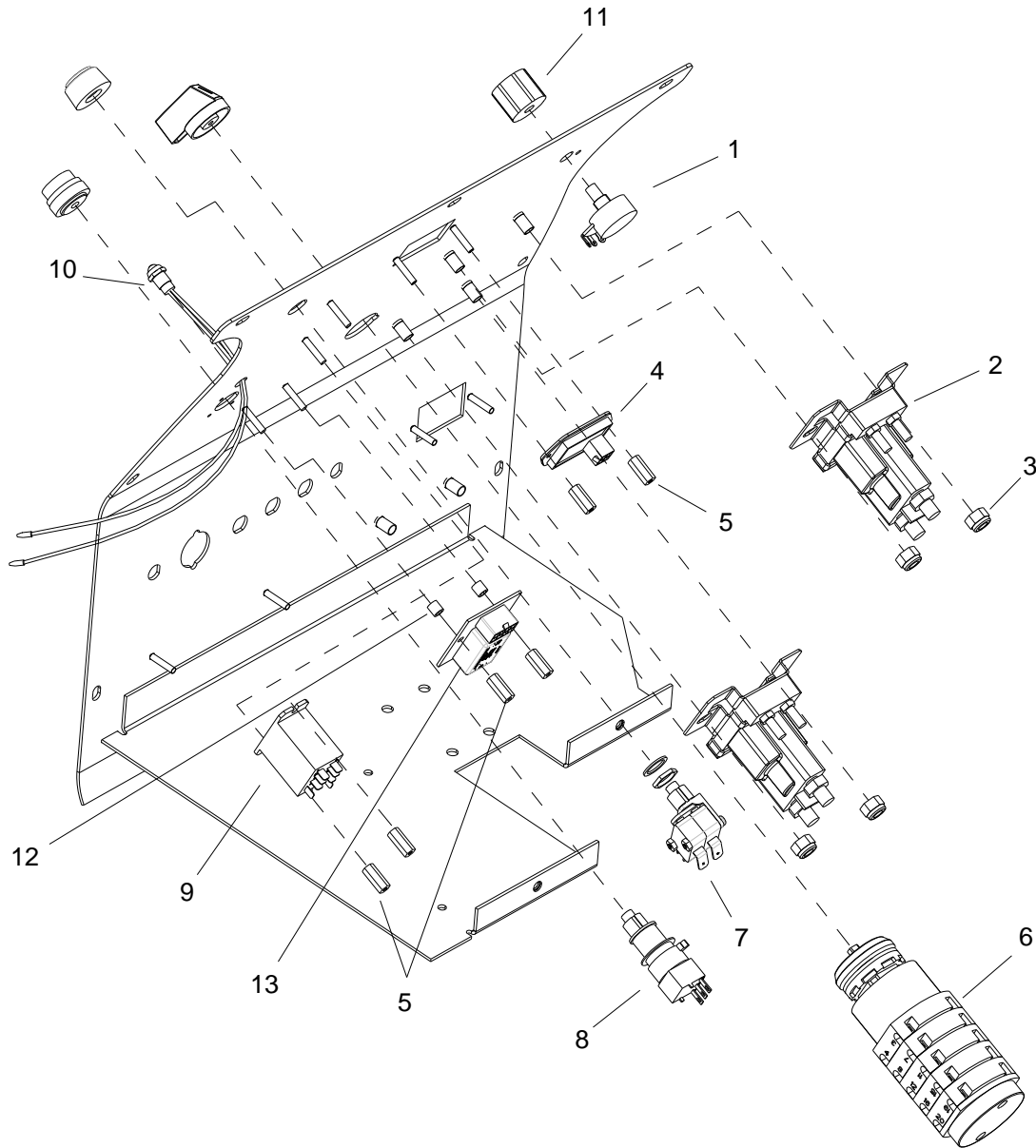

CONTROL PANEL - UPPER - DELUXE

REF	PART NO.	PRV NO.	QTY	DESCRIPTION	SERIAL NO. FROM	NOTES:
1	86250280	66135	1	POTENTIOMETER, 5K OHMS		
2	86251360	67166	2	RELAY, 36VDC 100A		
3	86005810	57245	4	NUT, 1/4-20 HEX NYLOCK SS		
4	86012670	-	1	METER, BTRY, PG TRUE CHRG		
5	86255900	73538	6	STANDOFF, 6-32 X 5/8 HEX NYL		
6	86014690	-	1	SWITCH, ROTARY CAM, 4 POS		
7	86257180	72207	1	SWITCH, MOMENTARY, DPDT, WHT		
8	86257150	72197	1	SWITCH, SPDT P-BUTTON		
9	86251410	67506	1	RELAY, 15A, 36V MINI		
10	86026010	82522	1	LIGHT ASM, INDICATOR		
11	86242110	48088	1	KNOB, .90 OD X .25 COLLET		
12	86254640	82810	2	SPACER, .25 OD X .171 ID X .25		
13	86300140	-	1	ASM, DC CONV.	**	WAS 86296100

** CALL MANUFACTURER FOR SERIAL NUMBER.

CONTROL PANEL MOUNTING

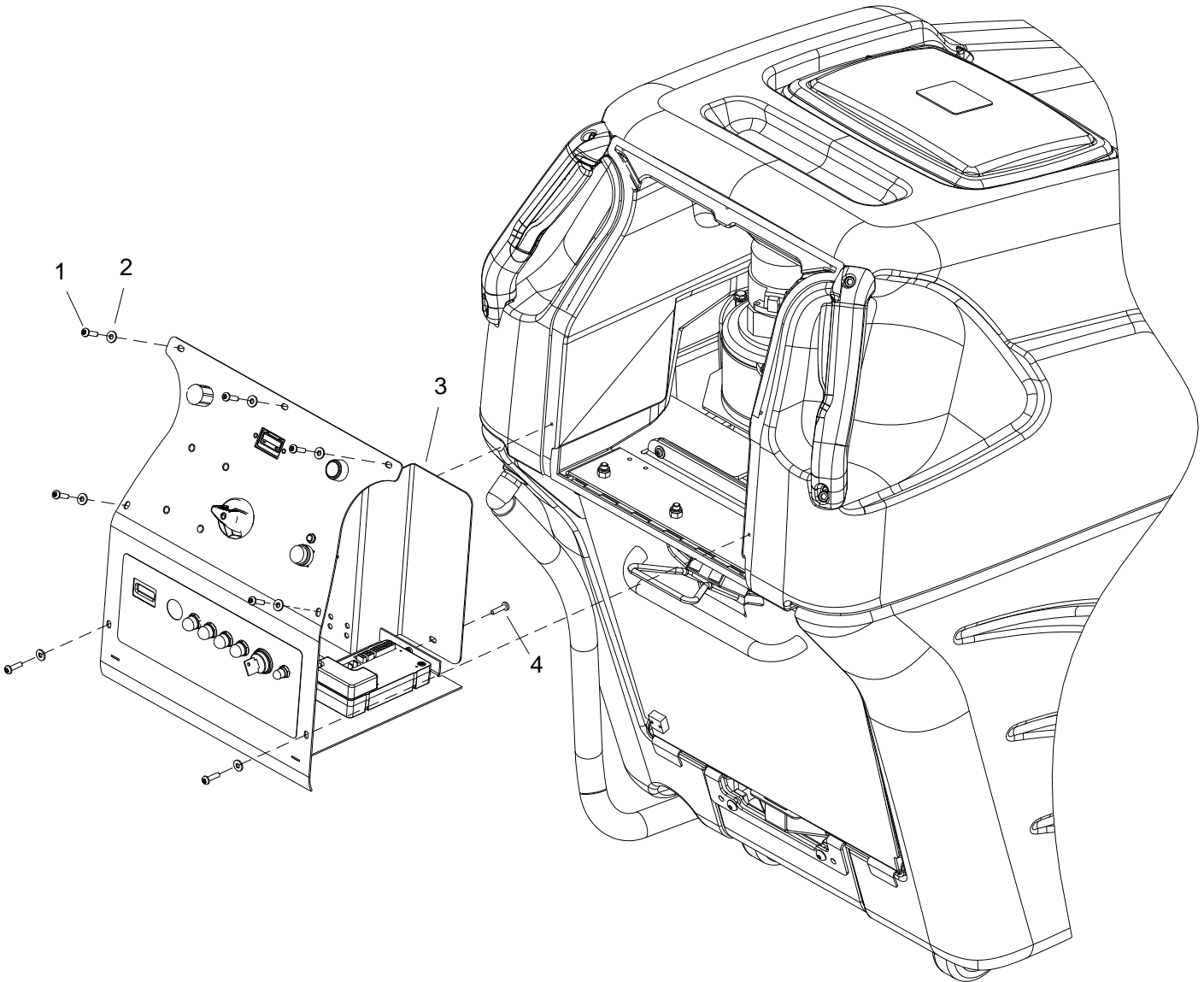

CONTROL PANEL MOUNTING

REF	PART NO.	PRV NO.	QTY	DESCRIPTION	SERIAL NO. FROM	NOTES:
1	86276290	70626	7	SCR, #10 X 3/4 PPHST HI-LO BLK		
2	86294250	-	7	WASHER, .19 ID X .5 X .09TK BLK		
3	86072110	141056	1	BRKT, BACK, CONTROL PANEL		
4	86274290	70162	2	SCR, 10-32 X 3/8 PPHMS SS		

COVER - FRONT

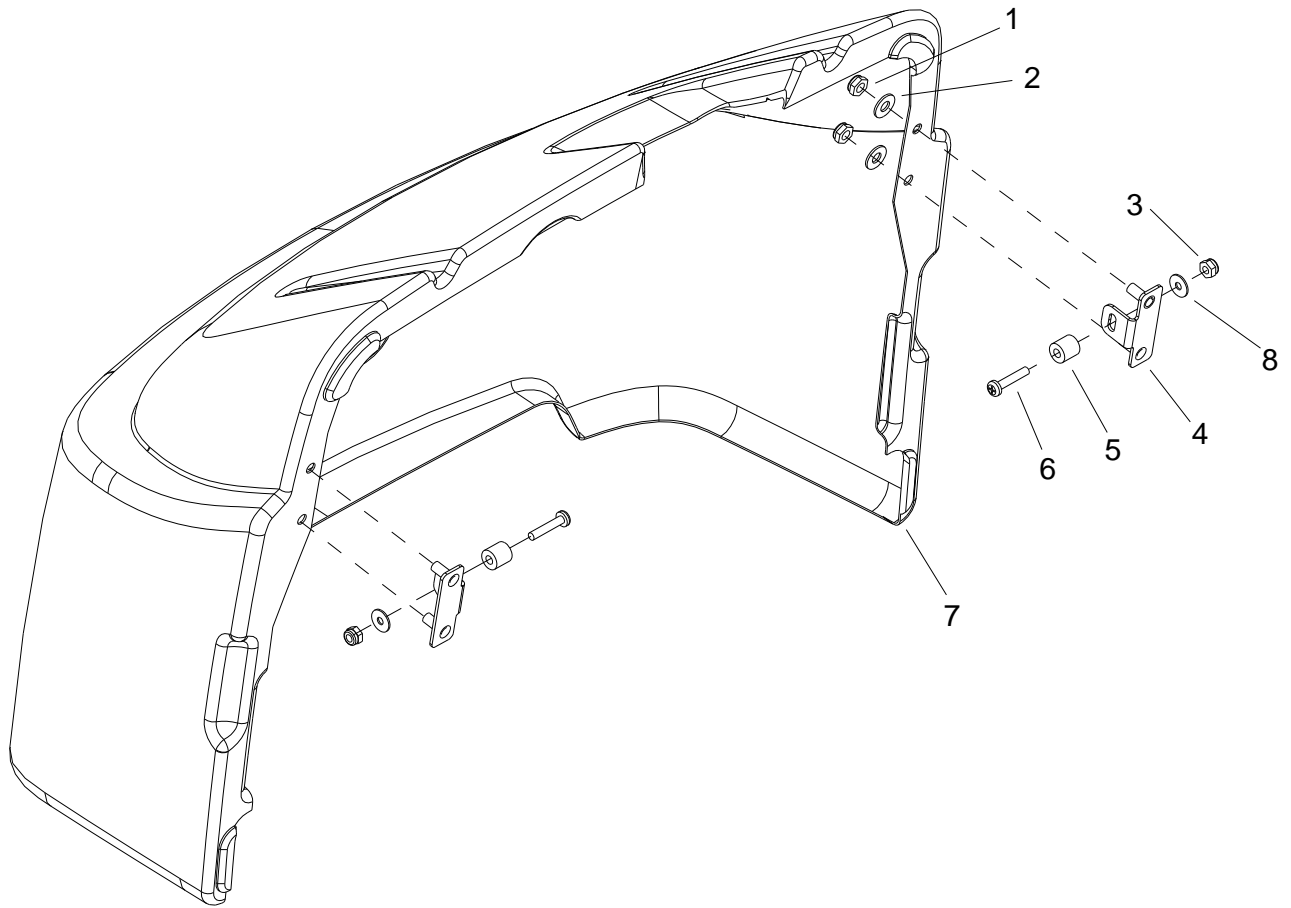

COVER - FRONT

REF	PART NO.	PRV NO.	QTY	DESCRIPTION	SERIAL NO. FROM	NOTES:
1	86271870	57290	4	NUT, 1/4-20 HEX NYLCK THIN SS		
2	86010630	87013	4	WASHER, 1/4ID X 5/8 OD SS		
3	86270990	57090	2	NUT, 10-32 HEX NYLOCK SS		
4	86290740	-	2	BRKT, FRONT LATCH		
5	86278390	73866	2	SPACER, 1/2ODX.219IDX1/2 NYLO		
6	86006830	70386	2	SCR, 10-32 X 1.0 PPHMS		
7	86062310	270155	1	COVER, FRONT, 24 IN DUO		
8	86010650	87018	2	WASHER, #10 X 9/16 OD		

DECAL

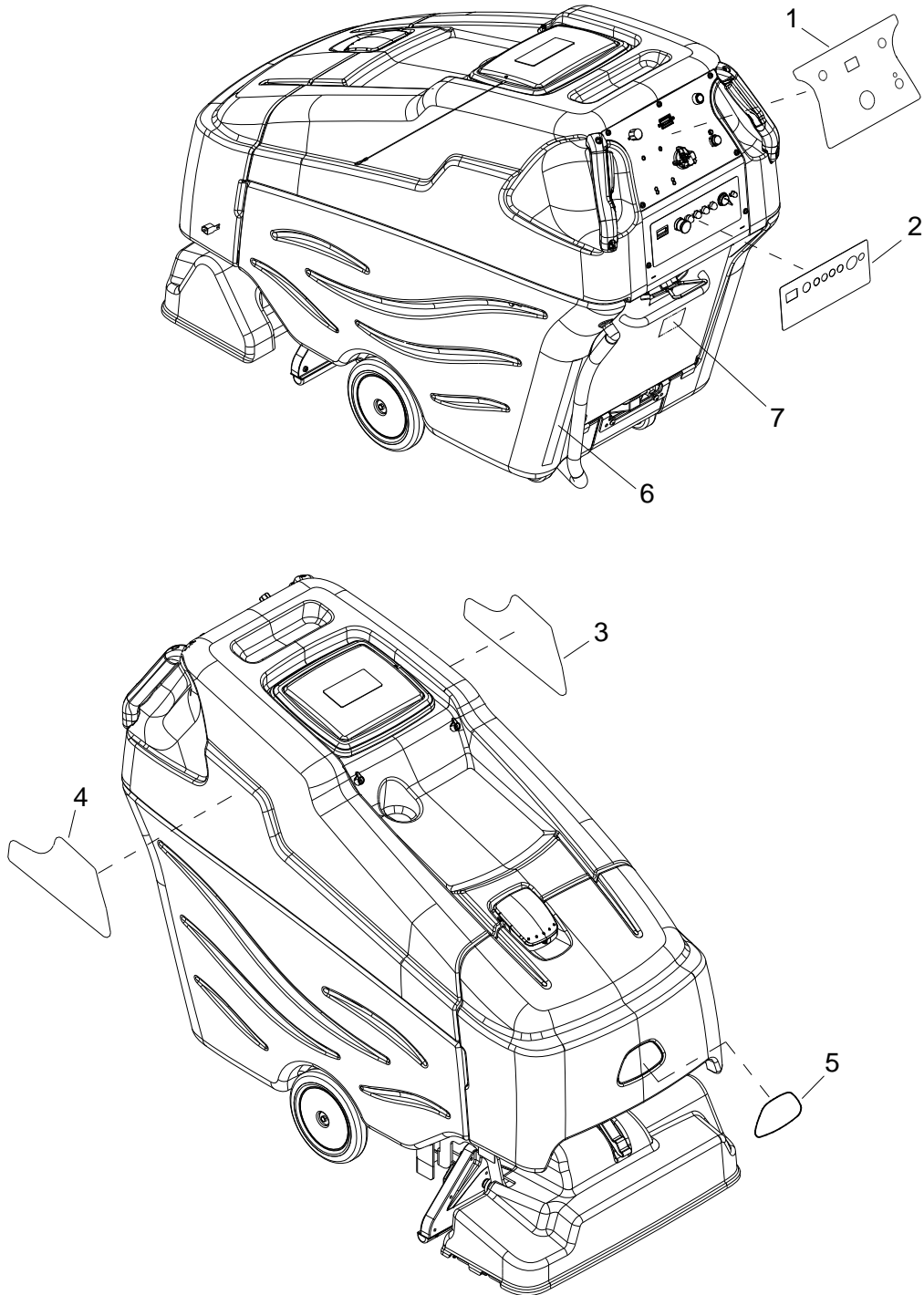

DECAL

REF	PART NO.	PRV NO.	QTY	DESCRIPTION	SERIAL NO. FROM	NOTES:
1	86013290	-	1	LABEL, BASIC CONTROL		
2	86013310	-	1	LABEL, EXTRACTORS, BREAKERS		
3	86013650	-	1	LABEL, VOYAGER, LEFT		
4	86013660	-	1	LABEL, VOYAGER, RIGHT		
5	86004970	50990	1	LABEL, WINDSOR LOGO DOMED		
6	86013330	-	1	LABEL, SOL FILL, 30 GAL		
7	86014330	-	1	LABEL, CHARGER CONNECTION		

FRAME - LOWER

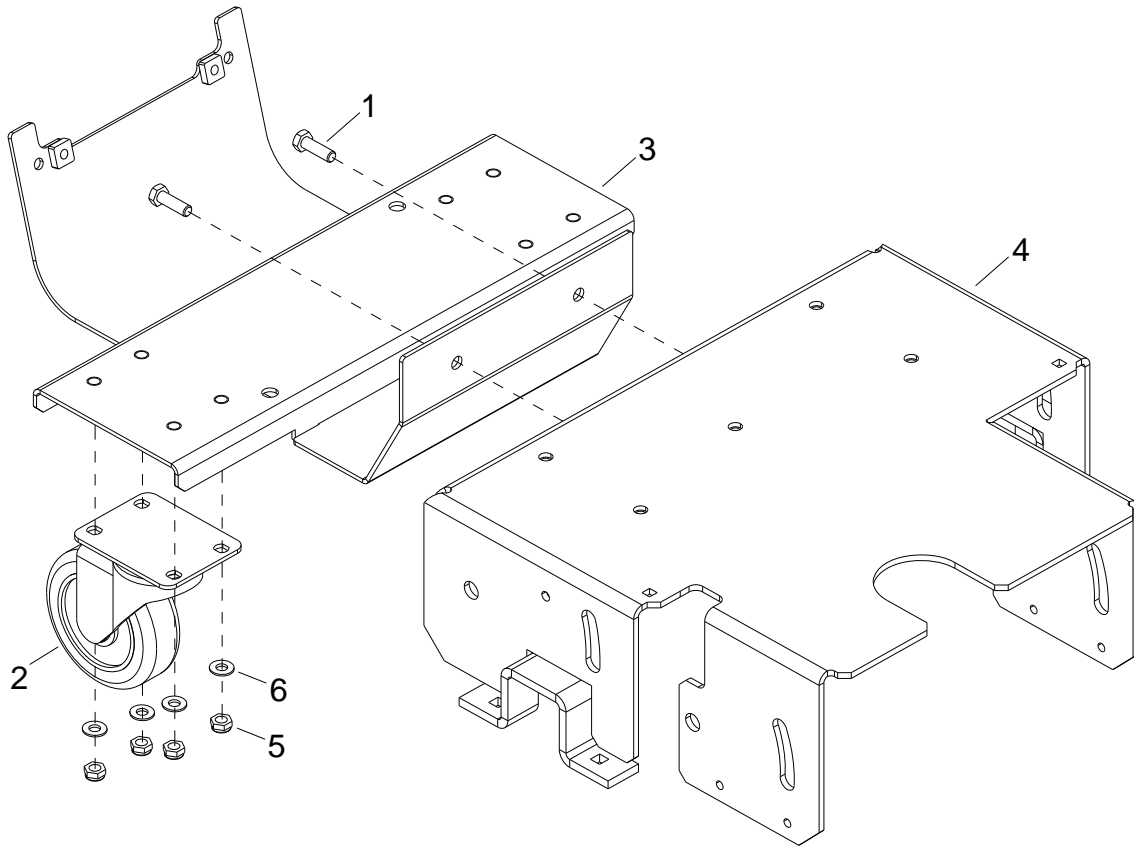

FRAME - LOWER

REF	PART NO.	PRV NO.	QTY	DESCRIPTION	SERIAL NO. FROM	NOTES:
1	86276780	70728	2	SCR, 5/16-18 X 3/4 HHCS SS		
2	86293740	-	2	CASTER, 4" SWIVEL, 300# CPCTY		
3	86091890	141022	1	BRKT, FRAME, CASTER MNT		
4	86092550	34468	1	FRAME, TRANSAXLE MTG		
5	86271840	57285	8	NUT, 5/16-18 HEX NYLCK THIN SS		
6	86010670	87029	8	WASHER, 5/16 FLAT SS		

FRAME - UPPER

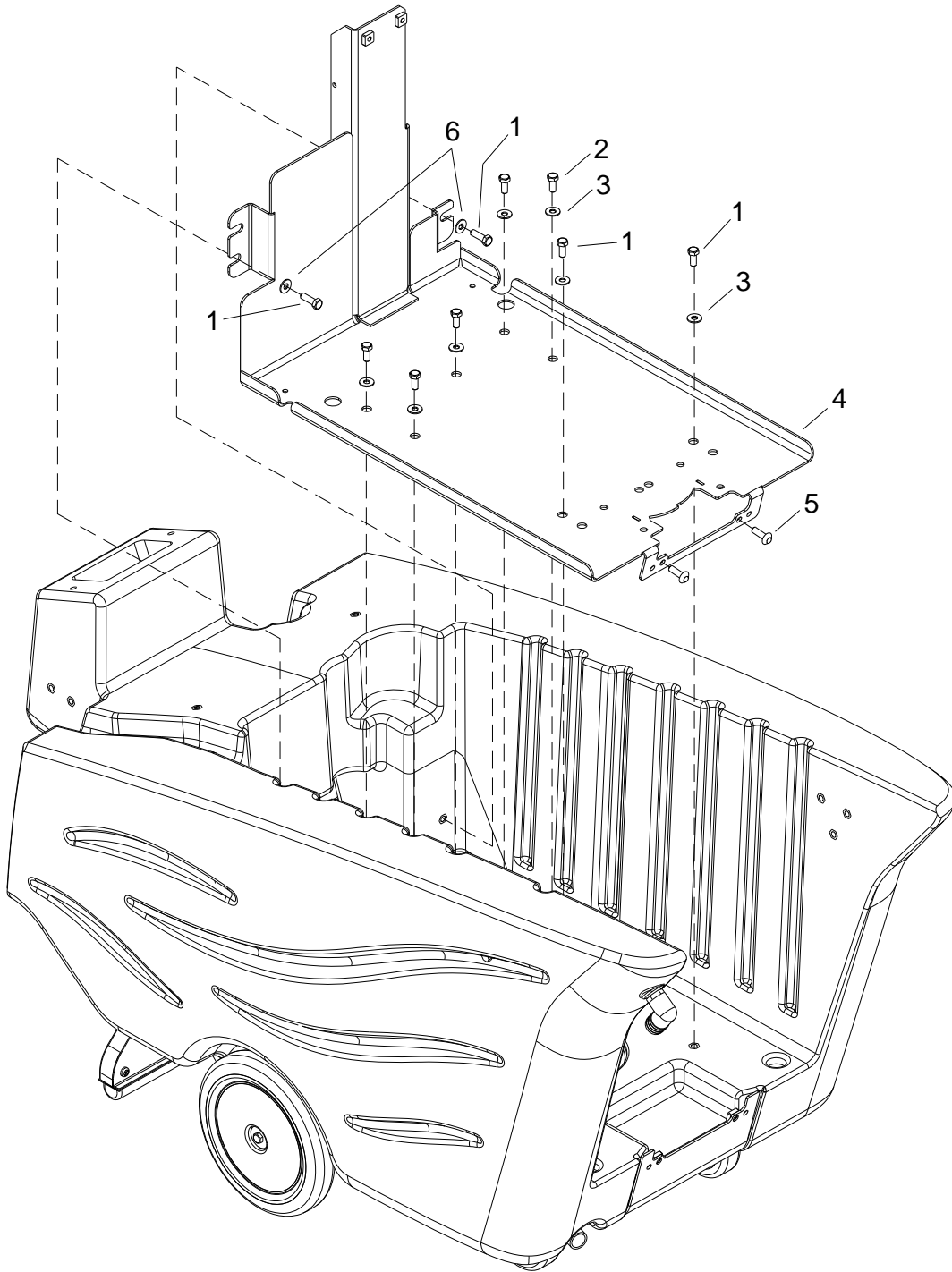

FRAME - UPPER

REF	PART NO.	PRV NO.	QTY	DESCRIPTION	SERIAL NO. FROM	NOTES:
1	86276780	70728	4	SCR 5/16-18 X 3/4 HHCS SS		
2	86276490	70670	5	SCR, 5/16-18 X 5/8 HHCS SS		
3	86010670	87029	7	WASHER, 5/16 FLAT SS		
4	86012890	-	1	WELDMENT, FRAME MAIN		
5	86277460	70847	2	SCR, 5/16-18 X 5/8 BSHCS SS		
6	86279630	87212	2	WASHER, .344IDX1.13ODX09TPLT		

RECOVERY TANK

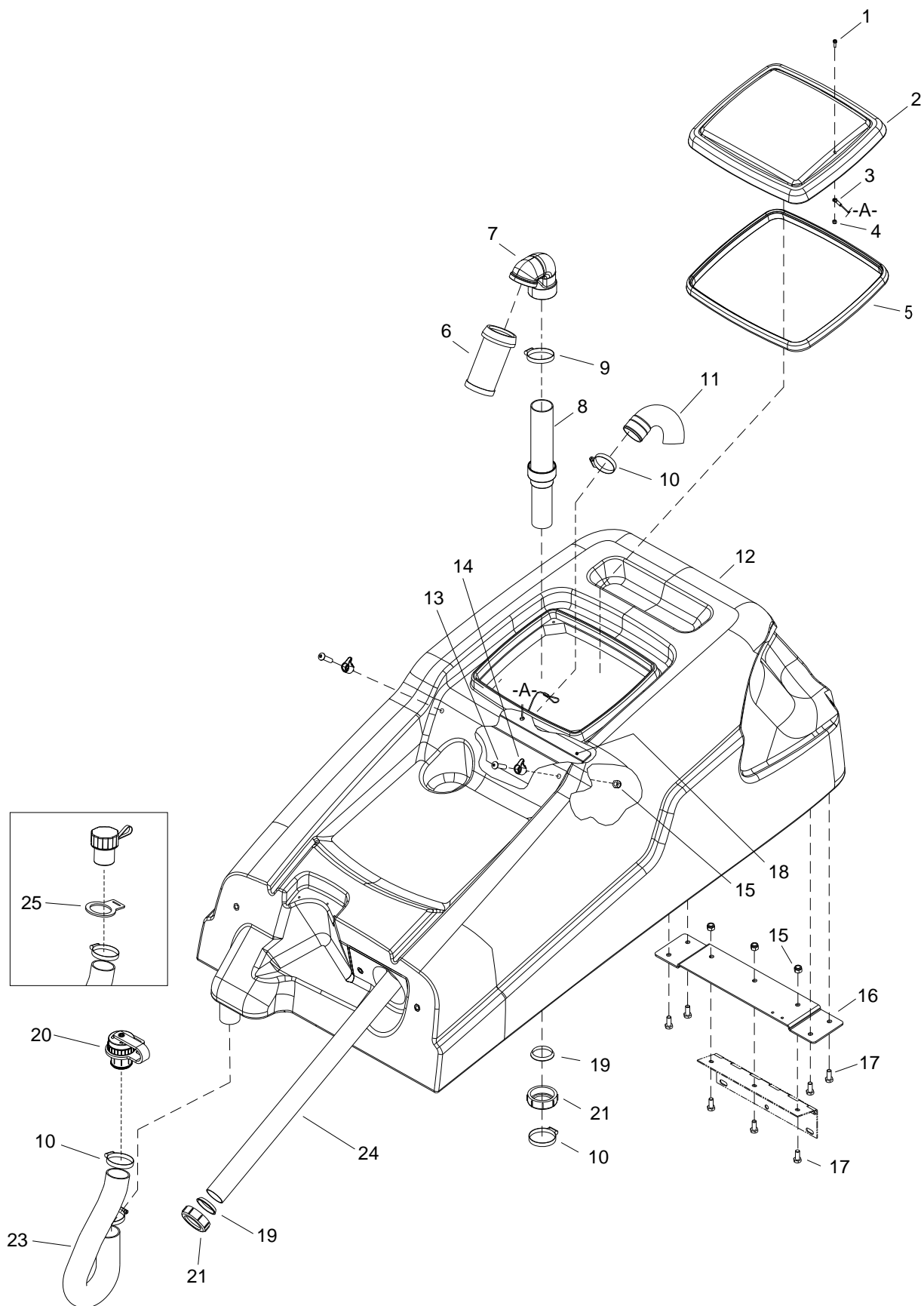

RECOVERY TANK

REF	PART NO.	PRV NO.	QTY	DESCRIPTION	SERIAL NO. FROM	NOTES:
1	86274220	70134	1	SCR, 6-32 X 5/8 PPHMS SS		
2	86003340	28062	1	DOME, 13 X 11		
3	86246080	51368	1	LANYARD, 18.0 W/LOOP & EYE		
4	86014810	-	1	NUT, 6-32 ACORN SS		
5	86004010	35274	1	GASKET, DOME EDGE		
6	86199840	090-12A	1	FLOAT SCREEN CAGE ASSY		
7	86227120	04095	1	ADAPTER, FLOAT 30 DEG		
8	86293240	-	1	TUBE ASM RECOVERY FLOAT		
9	86002380	20046	1	CLAMP, 2.25" WORM GEAR		
10	86002400	20064	4	CLAMP, 2.0" WORM GEAR X 312W		
11	86240130	39560	1	HOSE, P-TRAP 45 DEF		
12	86292750	-	1	SOLUTION TANK		
13	86290830	-	2	SCR, 5/16-18 X 1.25 SHCS SS		
14	86238460	36259	2	HOOK, STRAP		
15	86270830	57023	5	NUT, 5/16-18 HEX NYLOCK SS		
16	86013350	-	1	BRKT, RECOVERY HINGE		
17	86276490	70670	7	SCR, 5/16-18 X 5/8 HHCS SS		
18	86012160	-	1	BRKT, TANK STIFFENER		
19	86237650	35219	2	GASKET, 1 1/2 COMPRESSION		
20	86328980	-	1	DRAIN CAP ASSEMBLY		
21	86005660	57033	2	NUT, 1.5 SLIP JOINT		
22	OPEN	-	-	-		
23	86004260	39472	1	HOSE, 1.5 X 24.0 DRAIN		
24	86089630	78490	1	TUBE, 1.5 PVC X 24.0		
25	86246070	51352	1	LANYARD, DRAIN HOSE		

RECOVERY TANK HANDLE - BASIC

REF	PART NO.	PRV NO.	QTY	DESCRIPTION	SERIAL NO. FROM	NOTES:
1	86217470	270800	1	COVER, ACCESSORY PORT		
2	86290950	-	1	ASSEMBLY, BRKT, FRONT, LEFT		
3	86226740	73215	4	SPACER, 3/8 X .265 X 1/4 NYL		
4	86277640	70893	4	SCR, 1/4-20 X 3/4 PTHMS SS		
5	86290730	-	2	LATCH, FRONT COVER		
6	86010630	87013	6	WASHER, 1/4 ID X 5/8 OD SS		
7	86271870	57290	6	NUT 1/4-20 HEX NYLCK THIN SS		
8	86010670	87029	3	WASHER, 5/16 FLAT SS		
9	86276490	70670	3	SCR, 5/16-18 X 5/8 HHCS SS		
10	86290850	-	1	SCR, M5 X 25 HHMS SS		
11	86010650	87018	1	WASHER, #10 X 9/16 OD		
12	86013990	-	1	BRKT, COVER		
13	86291740	-	1	ASSEMBLY, BRKT, FRONT, RIGHT		
14	86276290	70626	2	SCR, #10X3/4 PPHST HI-LO BLK		
15	86010800	87189	2	WASHER, .2IDX.500 BLK SS		
16	86008650	80604	2	COTTER, 1/4" RING		
17	86222620	66891	1	PIN, 5MM DIA X 85MM L		
18	86002400	20064	1	CLAMP, 2.0 WORM GEAR X .312W		
19	86281980	39549	1	HOSE, 1/2ID WIRE BOUND X 5"		

RECOVERY TANK HANDLE - DELUXE

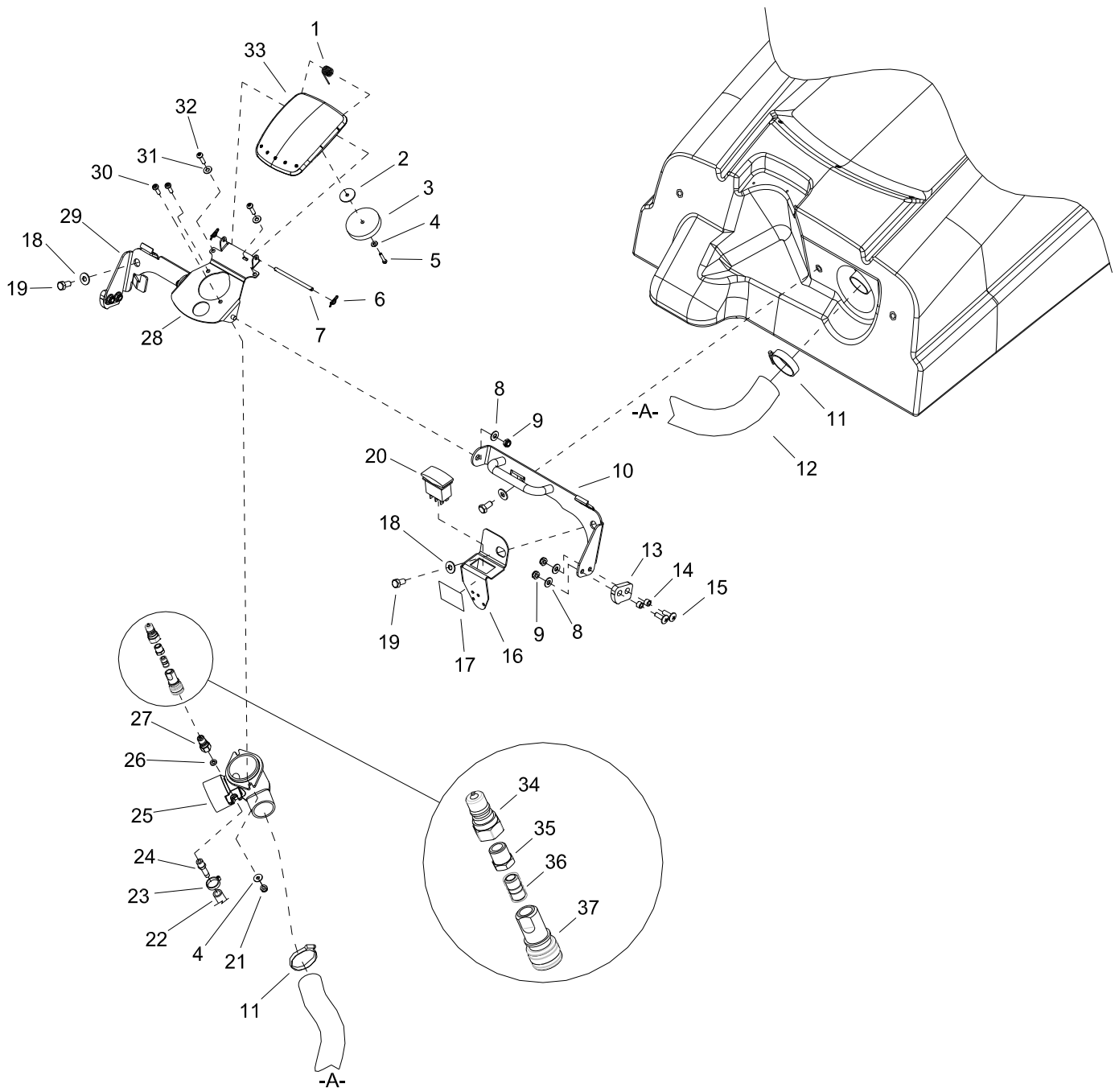

RECOVERY TANK HANDLE - DELUXE

REF	PART NO.	PRV NO.	QTY	DESCRIPTION	SERIAL NO. FROM	NOTES:
1	86224770	739989	1	SPRING, TORSION		
2	86279170	87093	1	WASHER, #10 X 1.0 FLAT		
3	86295160	-	1	GASKET, ACSY PORT COVER		
4	86010650	87018	3	WASHER, #10 X 9/16 OD		
5	86290850	-	1	SCR, M5 X 25 HHMS SS		
6	86008650	80604	2	COTTER, 1/4" RING		
7	86222620	66891	1	PIN, 5MM DIA X 85MM L		
8	86010630	87013	6	WASHER 1/4 ID X 5/8 OD SS		
9	86271870	57290	6	NUT, 1/4-20 HEX NYLOCK THIN SS		
10	86290950	-	1	ASSEMBLY, BRKT, FRONT, LEFT		
11	86002400	20064	2	CLAMP, 2.0" WRM GEAR X .312W		
12	86297600	-	1	HOSE ASM, 1.5 BLK VAC X 6.5		
13	86290730	-	2	LATCH, FRONT COVER		
14	86226740	73215	4	SPACER, 3/8 X .265 X 1/4 NYL		
15	86277640	70893	4	SCR, 1/4-20 X 3/4 MS SS		
16	86293920	-	1	BRKT, PRIMER SWITCH		
17	86295720	-	1	LABEL, PRIMING		
18	86010670	87029	3	WASHER, 5/16 FLAT SS		
19	86276490	70670	3	SCR, 5/16-18 X 5/8 HHCS SS		
20	86007210	72165	1	SWITCH, DPDT 3-PSTN ROCKER		
21	86270990	57090	2	NUT, 10-32 HEX NYLOCK SS		
22	86295830	-	1	HOSE, 1/4ID NYLOBRAID X 41"		
23	86002400	20064	1	CLAMP, 2.0" WORM GEARX.312W		
24	86197520	40011	1	HOSEBARB, 1/8MPT X 1/4 DL		
25	86217270	22110	1	COUPLER, ACC PORT VACUUM		
26	86278910	87003	1	WASHER, 3/8 ID X 7/8 OD SS		
27	86200820	270-11A	1	NIPPLE, 1/8FPT QD MALE BRASS		
28	86294880	-	1	BRKT, ACC PORT COVER		
29	86291740	-	1	ASSEMBLY, BRKT, FRONT, RIGHT		
30	86275470	70484	2	SCR, 10-32 X 5/8 PPHMS SS		
31	86010800	87189	2	WASHER, M8 SPLIT LOCK		
32	86276290	70626	2	SCR, #10X3/4 PPHST HI-LO BLK		
33	86217470	270800	1	COVER, ACCESSORY PORT		
34	86005580	56012	1	NIPPLE, 1/4 FPT QD	*(1,2,3,4)	
35	86197300	14079	1	BUSHING, 1/8 FPT X 1/4 MPT HEX	*(1,2,3,4)	
36	86247720	56032	1	NIPPLE, 1/8 CLOSE	*(1,2,3,4)	
37	86200810	270-11	1	NIPPLE, 1/8 FPT QD FEM BRASS	*(1,2,3,4)	

* SEE SERIAL NUMBER PAGE.

SOLUTION – CHEMICAL TANKS - DELUXE

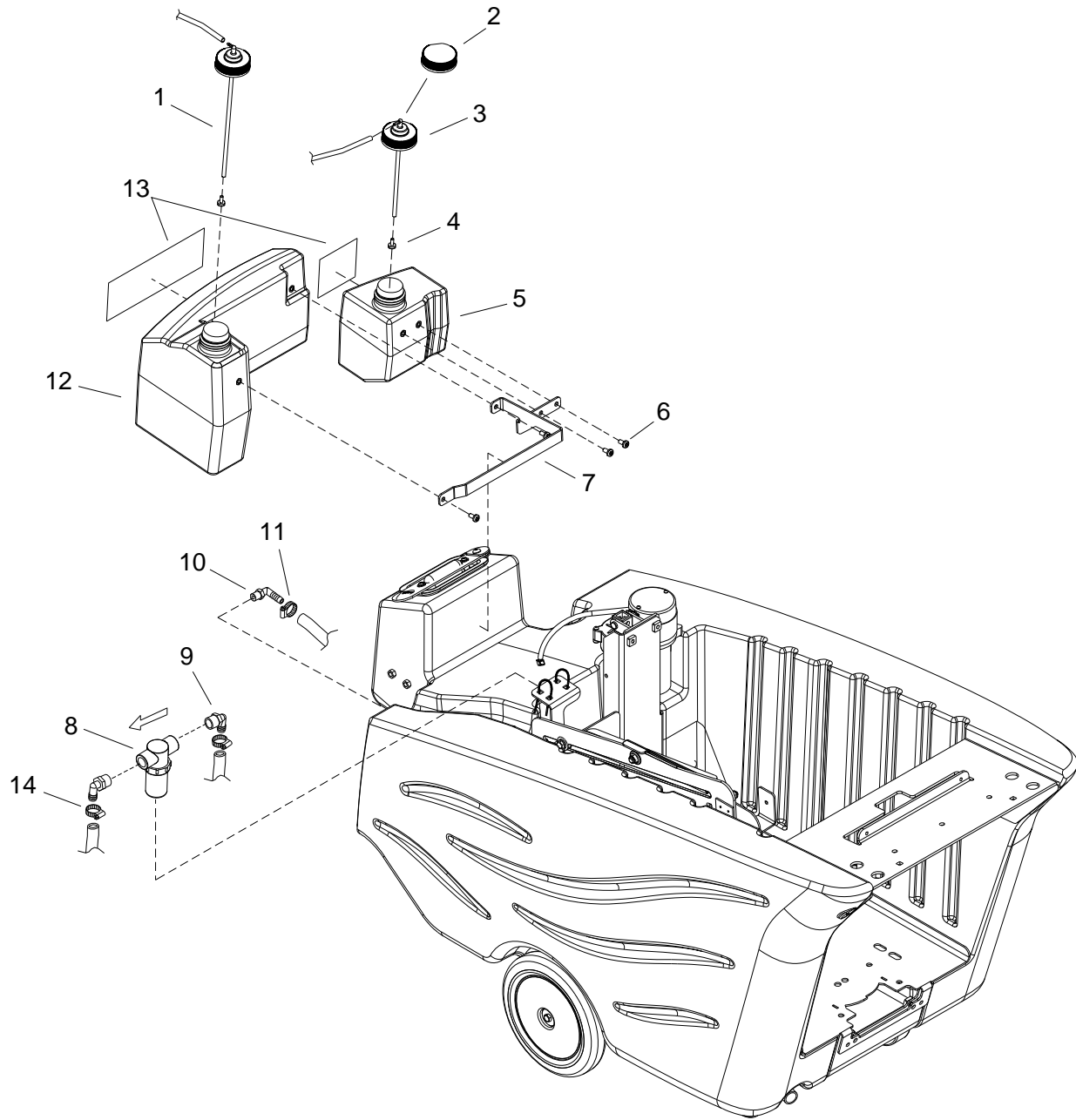

SOLUTION – CHEMICAL TANKS - DELUXE

REF	PART NO.	PRV NO.	QTY	DESCRIPTION	SERIAL NO. FROM	NOTES:
1	86295330	-	1	CAP, DISPENSING, 9.50 TUBE		
2	86295280	-	2	CAP, STORAGE		
3	86295310	-	1	CAP, DISPENSING, 6.50 TUBE		
4	86236590	34448	2	FOOT FILTER		
5	86088710	75495	1	TANK, EXTRACT CHEMICAL		
6	86274400	70194	4	SCR, 1/4-20 X 5/8 BHCS		
7	86294870	-	1	BRKT, CHEMICAL TANKS		
8	86012760	-	1	STRAINER, 1/2 FPT, 80 MESH		
9	86001530	40039	2	HOSEBARB, 1/2MPTX1/2 HOSE 90		
10	86297610	-	1	HOSEBARB, 1/4MPTX1/4 90D NYL		
11	86233090	20016	1	CLAMP, 1/4 HOSE		
12	86088690	75494	1	TANK, INTERIM CHEMICAL		
13	86295710	-	1	LABEL, CHEMICAL TANKS		
14	86233150	20042	2	CLAMP, 3/8 HOSE (D-SLOT)		

SOLUTION PUMP

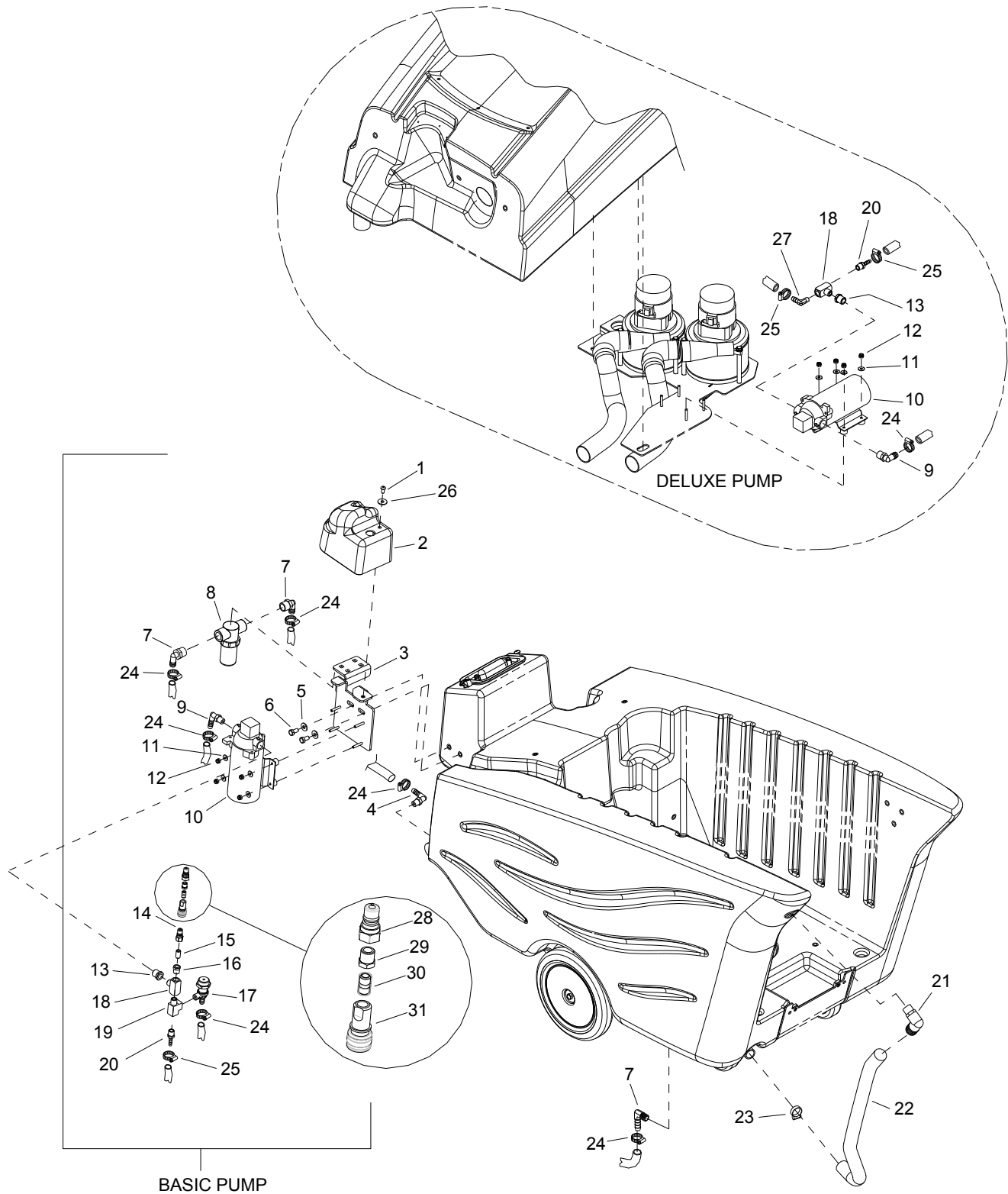

SOLUTION PUMP

REF	PART NO.	PRV NO.	QTY	DESCRIPTION	SERIAL NO. FROM	NOTES:
1	86006580	70085	1	SCR, 1/4-20 X 1/2 PPHMS SS DL		
2	86292230	-	1	COVER, PUMP		
3	86012690	-	1	BRKT, PUMP MTG		
4	86240500	40095	1	HOSEBARB, 1/4MPT X 3/8 90D NYL		
5	86010670	87029	2	WASHER, 5/16 FLAT SS		
6	86276490	70670	2	SCR, 5/16-18 X 5/8 HHCS SS		
7	86001530	40039	3	HOSEBARB, 1/2MPT X 1/2 HOSE 90		
8	86012760	-	1	STRAINER, 1/2 FPT, 80 MESH		
-	86005870	59021	-	O-RING, FILTER SEAL RON-VIK		
-	86136800	73839	-	SCREEN, 100 MESH STRAINER DEEP		
9	86197940	40027	1	HOSEBARB, 3/8MPTX1/2 90D DL		
10	86006100	65176	1	PUMP ASM, 36V ACCESSORY		
11	86010650	87018	4	WASHER, #10 X 9/16 OD		
12	86270990	57090	4	NUT, 10-32 HEX NYLOCK SS		
13	86197290	14076	1	BUSHING, 3/8 MPT X 1/4 FPT HEX		
14	86200820	270-11A	1	NIPPLE, 1/8NPT QD MALE BRASS		
15	86247720	56032	1	NIPPLE, 1/8 CLOSE		
16	86197300	14079	1	BUSHING, 1/8 FPT X 1/4 MPT HEX		
17	86290000	-	1	VALVE, BYPASS, 125 PSI ADJ		
18	86197730	78024	1	TEE, 1/4 BRANCH		
19	86197760	78308	1	TEE, 1/4 STREET		
20	86197500	40009	1	HOSEBARB, 1/4MPT X 1/4 DL		
21	86197980	40055	1	HOSEBARB, 1/2 MPT X 1.0 90D NU		
22	86282050	39562	1	HOSE, 1.0 ID X 1/8W X 21 CLR		
23	86233110	20018	1	CLAMP, 1.0" WORM GEAR		
24	86233150	20042	7	CLAMP, 3/8 HOSE (D-SLOT)		
25	86233090	20016	2	CLAMP, 1/4 ID HOSE		
26	86010630	87013	1	WASHER, 1/4 ID X 5/8 OD SS		
27	86240360	40065	1	HOSEBARB, 1/4 MPT X 1/4 9D DL		
28	86005580	56012	1	NIPPLE, 1/4 FPT QD	*(1,2,3,4)	
29	86197300	14079	1	BUSHING, 1/8 FPT X 1/4 MPT HEX	*(1,2,3,4)	
30	86247720	56032	1	NIPPLE, 1/8 CLOSE	*(1,2,3,4)	
31	86200810	270-11	1	NIPPLE, 1/8 FPT QD FEM BRASS	*(1,2,3,4)	

* SEE SERIAL NUMBER PAGE.

SOLUTION – CHEMICAL PUMP - DELUXE

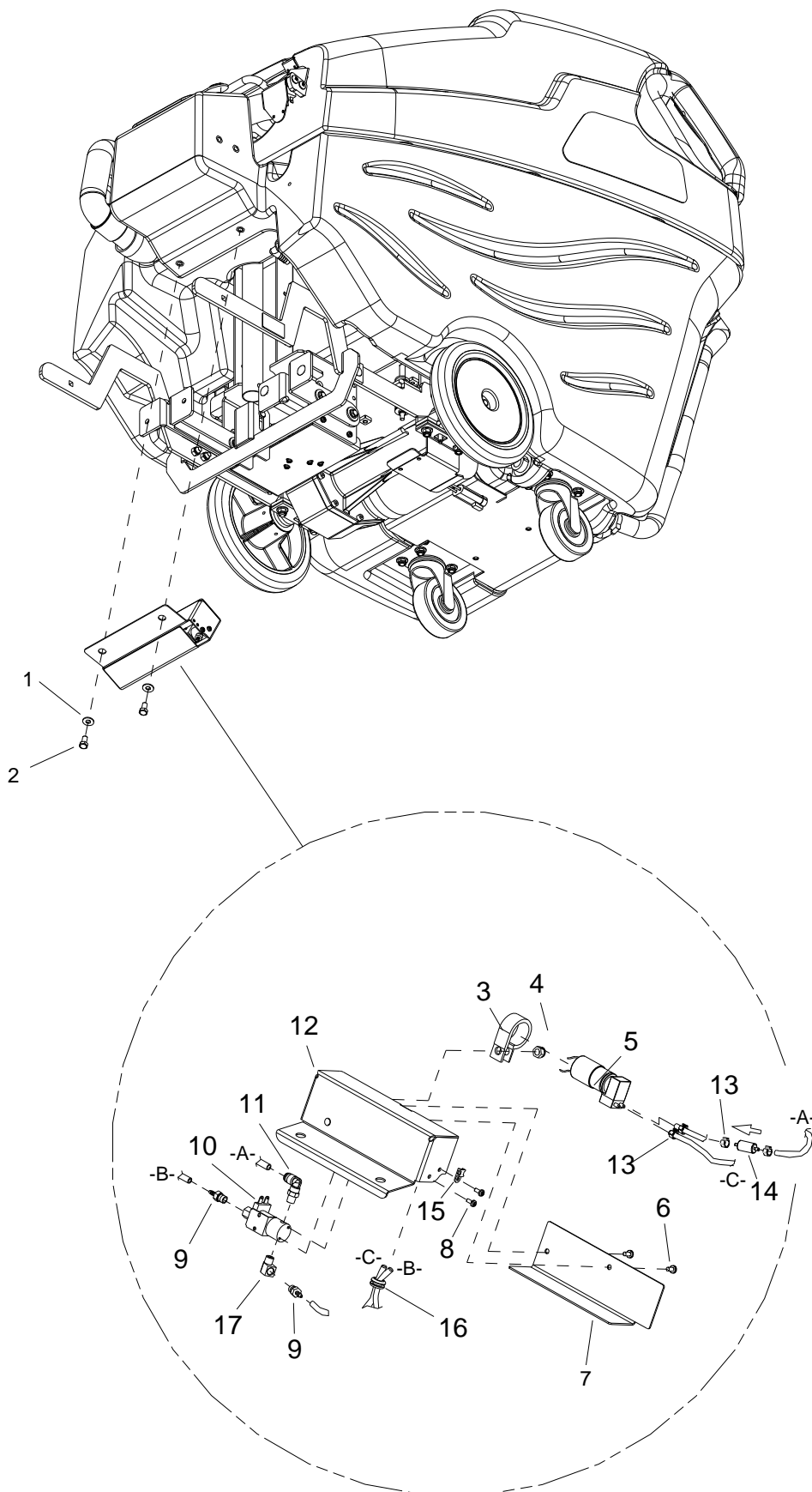

SOLUTION – CHEMICAL PUMP – DELUXE

REF	PART NO.	PRV NO.	QTY	DESCRIPTION	SERIAL NO. FROM	NOTES:
1	86010670	87029	2	WASHER, 5/16 FLAT SS		
2	86276490	70670	2	SCR, 5/16-18 X 5/8 HHCS SS		
3	86295370	-	1	CLAMP, 1-1/4 P CUSHIONED		
4	86270830	57023	1	NUT, 5/16-18 HEX NYLOCK SS		
5	86293710	-	1	PUMP, CHEMICAL, 85 PSI		
6	86274290	70162	2	SCR, 10-32 X 3/8 PPHMS SS		
7	86293970	-	1	BRKT, COVER		
8	86006520	70052	2	SCR, 8-32 X 3/8 PPHMS SS		
9	86295810	-	2	HOSEBARB, 1/8 MPT X 1/8		
10	86293720	-	1	VALVE, 3-WAY, 36 VDC		
11	86295290	-	1	ELBOW, SWVL, 6MM QC X 1/8 MPT		
12	86294280	-	1	BRKT, CHEMICAL PUMP		
13	86297460	-	4	CLAMP, 1/4" NYLON RATCHET		
14	86298040	-	1	FILTER, INLINE, 1/8 HOSE BARB		
15	86264860	05153	1	ANCHOR, CABLE TIE #8 MOUNT		
16	86238490	81388	1	GROMMET 3/8 ID X 1/8 GROOVE		
17	86197400	31022	1	ELBOW, 1/8 NPT STREET		

SOLUTION – CHEMICAL VALVES - DELUXE

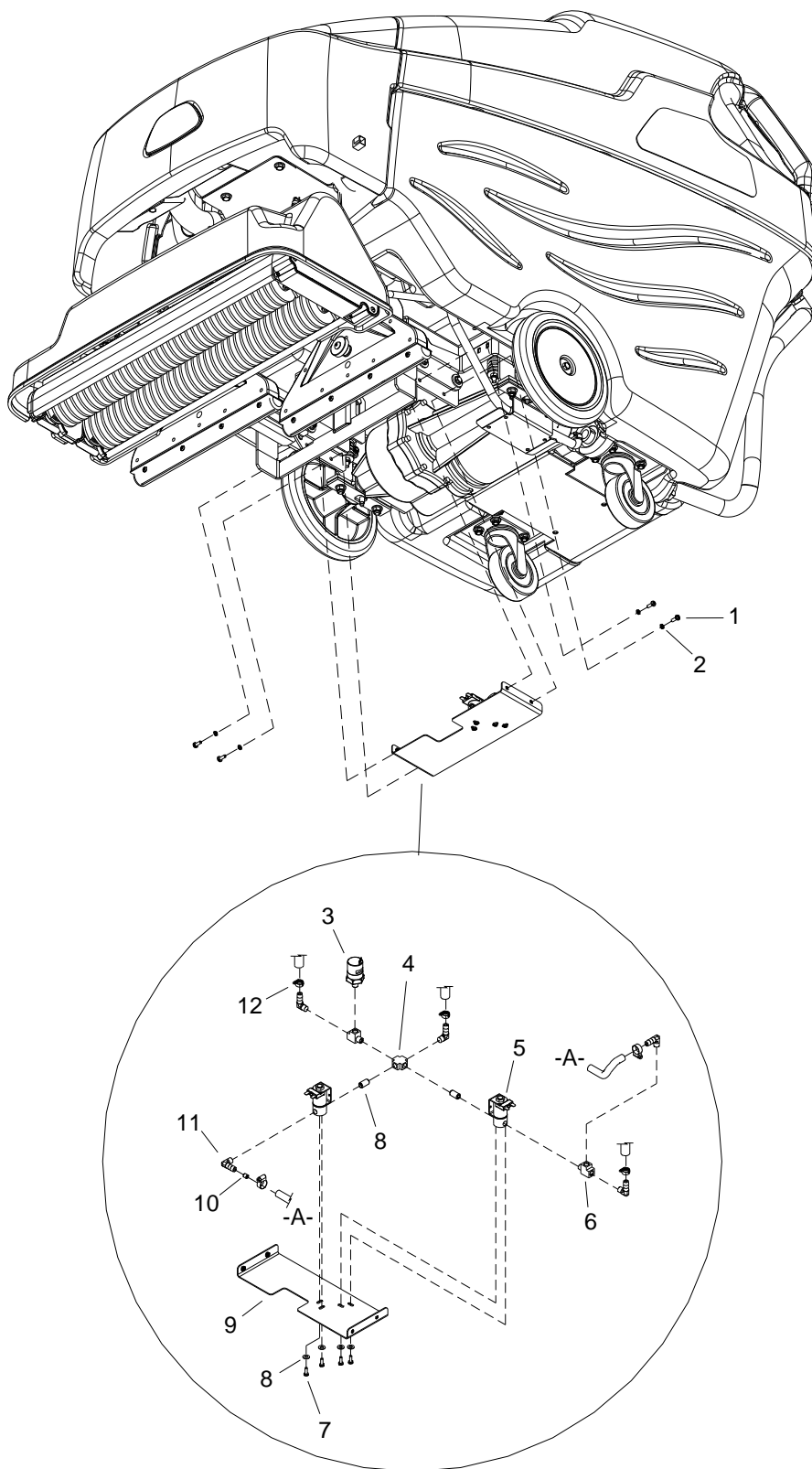

SOLUTION - CHEMICAL VALVES - DELUXE

REF	PART NO.	PRV NO.	QTY	DESCRIPTION	SERIAL NO. FROM	NOTES:
1	86273980	70066	4	SCR, 10-32 X 3/4 PPHMS SS		
2	86010650	87018	8	WASHER, #10 X 9/16 OD		
3	86293950	-	1	SWITCH, PRESSURE		
4	86295650	-	1	CROSS, 1/8 NPT		
5	86013030	-	2	VALVE, 36VDC SOLENOID, 1/8FPT		
6	86197750	78161	2	TEE, 1/8 NPT STREET RUN		
7	86006520	70052	4	SCR, 8-32 X 3/8 PPHMS SS		
8	86247720	56032	2	NIPPLE, 1/8 CLOSE		
9	86295250	-	1	BRKT SOLUTION BYPASS		
10	86295550	-	1	ORIFICE, SOLUTION BYPASS		
11	86240610	44104	5	HOSEBARB, 1/8MPT X 1/4H 90D		
12	86233090	20016	5	CLAMP, 1/4 ID HOSE		

SOLUTION TANK

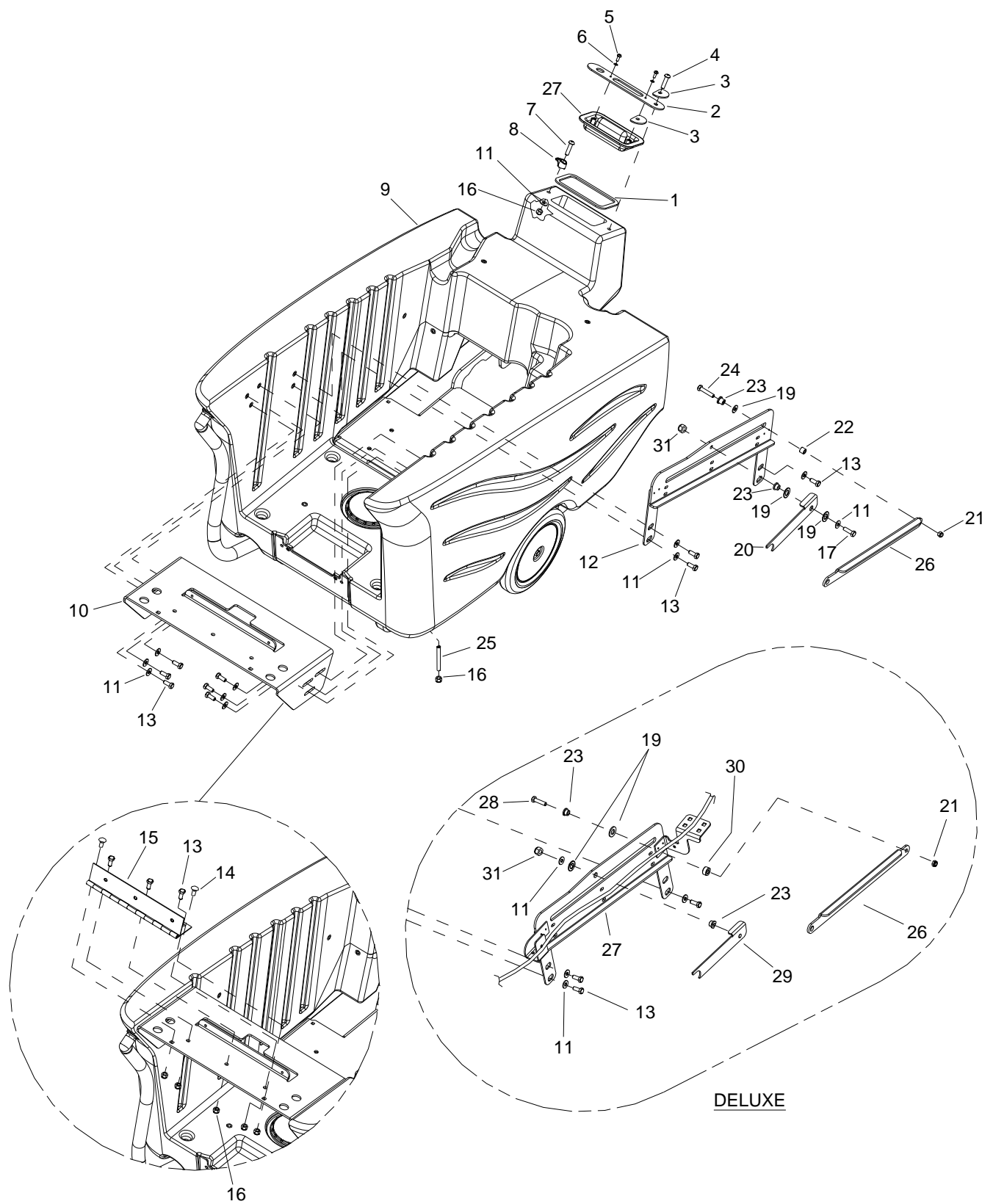

SOLUTION TANK

REF	PART NO.	PRV NO.	QTY	DESCRIPTION	SERIAL NO. FROM	NOTES:
1	86011820	-	1	GASKET, INLET CAP		
2	86011810	-	1	RETAINER, INLET CAP		
3	86290370	-	2	WASHER D, .346 ID X .105T		
4	86276760	70724	1	SCR, 5/16-18 X 1.25 BSHCS SS		
5	86006860	70403	2	SCR, #10 X 1/2 PPHST TYPE B SS		
6	86010650	87018	2	WASHER, #10 X 9/16 OD		
7	86290830	-	1	SCR, 5/16-18 X 1.25 SHCS SS		
8	86238460	36259	1	HOOK, STRAP		
9	86292760	-	1	TANK, SOLUTION		
10	86011400	-	1	BRKT, SOLUTION HINGE		
11	86010670	87029	12	WASHER, 5/16 FLAT SS		
12	86013700	-	1	WELDMENT, LIFT SIDE		
13	86276490	70670	12	SCR, 5/16-18 X 5/8 HHCS SS		
14	86276070	70593	2	SCR, 5/16-18 X 3/4 CARRIAGE SS		
15	86239630	41429	1	HINGE, COVER TO TANK		
16	86270830	57023	9	NUT, 5/16-18 HEX NYLOCK SS		
17	86006560	70083	1	SCR, 5/16-18 X 1 HHCS SS NP		
18	OPEN	-	-	-		
19	86259410	87206	3	WASHER, THRUST.51IDX1ODX.063		DELUXE QTY 2
20	86290190	-	1	BRKT, PROP ROD CATCH		
21	86271840	57285	1	NUT, 5/16-18 HEX NYLOCK THN SS		
22	86259910	89265	1	WHEEL, BATTERY TRAY		
23	86228990	09153	2	BEARING, FLNGD, .314D X .502D		
24	86274720	70264	1	SCR, 5/16-18 X 1.5 HHCS SS		
25	86276380	70639	2	SCR, 5/16-18 X 1.25 SSSCU		
26	86011630	-	1	PLATE, PROP ROD		
27	86217540	279994	1	COVER, SOLUTION TANK		
28	86007020	70673	1	SCR, 5/16-18 X 1.25 HHCS SS NP		
29	86295730	-	1	BRKT, PROP ROD CATCH		
30	86293700	-	1	SPACER, .75 X .322 ID X .38L		
31	86197040	57264	1	NUT, 5/16-18 HEX ACORN PLTD		

SPRAY JETS

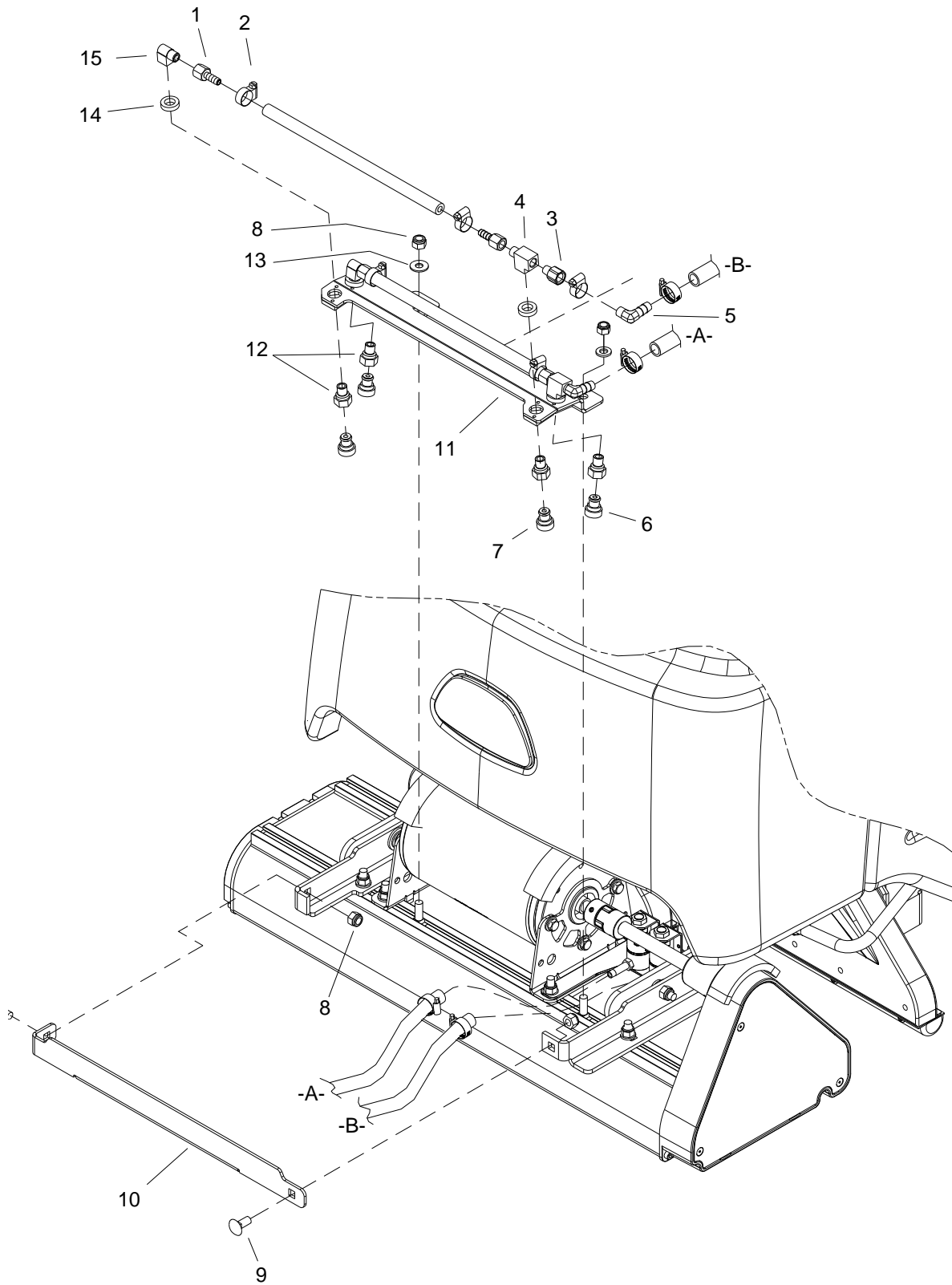

SPRAY JETS

REF	PART NO.	PRV NO.	QTY	DESCRIPTION	SERIAL NO. FROM	NOTES:
1	86197640	40064	4	HOSEBARB, 1/8" FPT X 1/4"		
2	86233090	20016	6	CLAMP, 1/4 ID HOSE		
3	86227200	04007	1	ADPTR 1/8MPTX1/8FPT BS AD		
4	86197750	78161	2	TEE, 1/8 NPT STREET RUN		
5	86240610	44104	2	HOSEBARB, 1/8MPT X 1/4H 90D		
6	86013200	-	2	JET, MINI PROMAX 11004		
7	86012550	-	2	JET, PROMAX, 11001		
8	86270830	57023	4	NUT, 5/16-18 HEX NYLOCK SS		
9	86276070	70593	2	SCR, 5/16-18 X 3/4 CARRIAGE SS		
10	86295590	-	1	PLATE, BUMPER		
11	86091870	141017	1	BRKT, JET, DUAL		
12	86004570	44067	4	JET BODY, MINI PROMAX BODY		
13	86010670	87029	2	WASHER, 5/16 FLAT SS		
14	86010820	87192	4	WASHER, 7/16 X 3/4 X .19 RBR		
15	86197400	31022	2	ELBOW, 1/8NPT STREET		

SPRAY JET VALVES - BASIC

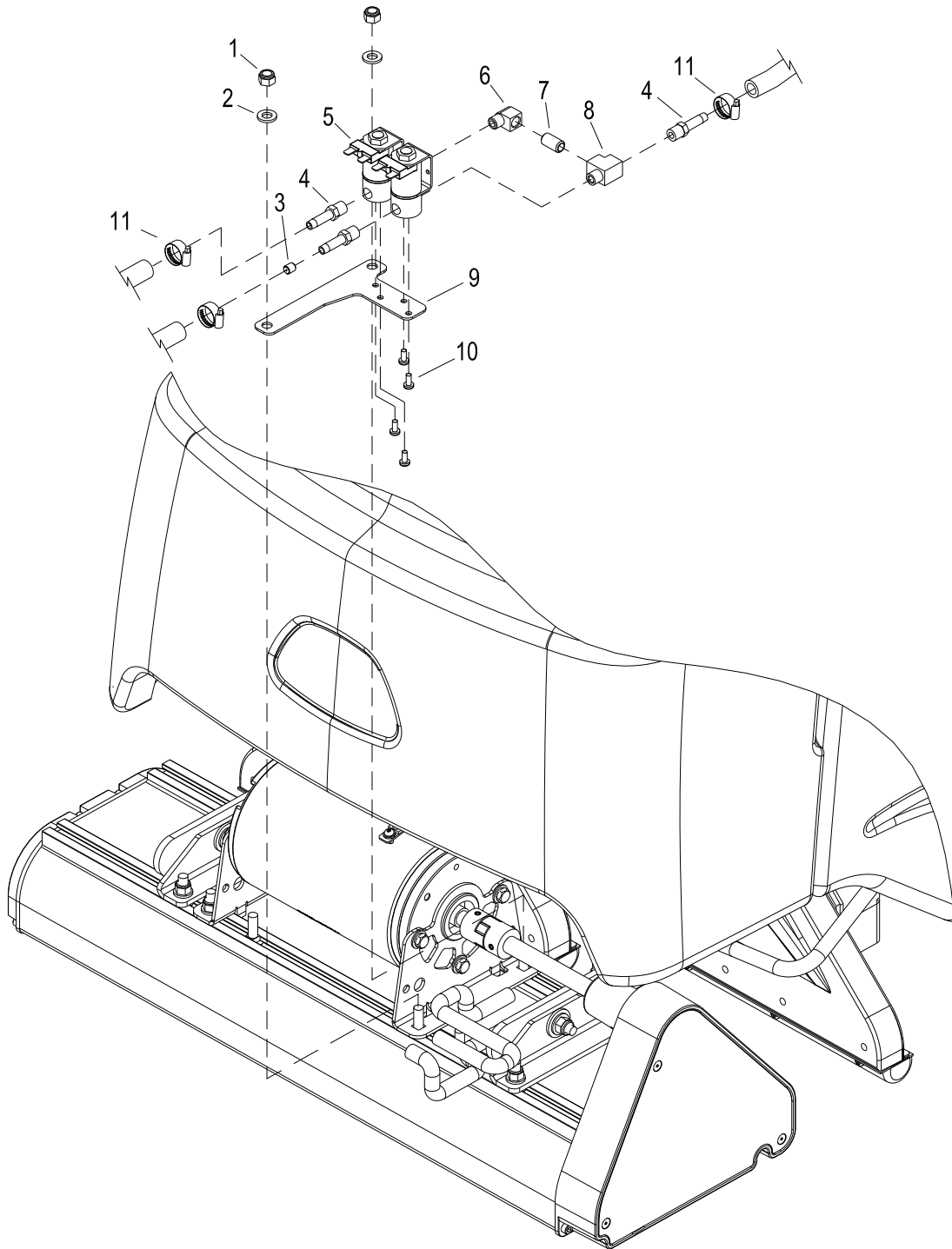

SPRAY JETS VALVES - BASIC

REF	PART NO.	PRV NO.	QTY	DESCRIPTION	SERIAL NO. FROM	NOTES:
1	86270830	57023	2	NUT, 5/16-18 HEX NYLOCK SS		
2	86010670	87029	2	WASHER, 5/16 FLAT SS		
3	86014250	-	1	ORIFICE, .052 ID, .281 OD		
4	86197520	40011	3	HOSEBARB, 1/8MPT X 1/4 DL		
5	86013030	-	2	VALVE, 36VDC SOLENOID, 1/8 FPT		
6	86197400	31022	1	ELBOW, 1/8NPT STREET		
7	86247720	56032	1	NIPPLE, 1/8 CLOSE		
8	86197750	78161	1	TEE, 1/8 NPT STREET RUN		
9	86013070	-	1	BRACKET, DUO VALVE MOUNT		
10	86006520	70052	4	SCR, 8-32 X 3/8 PPHMS SS		
11	86233090	20016	3	CLAMP, 1/4 ID HOSE		

SPRAY JET VALVES - DELUXE

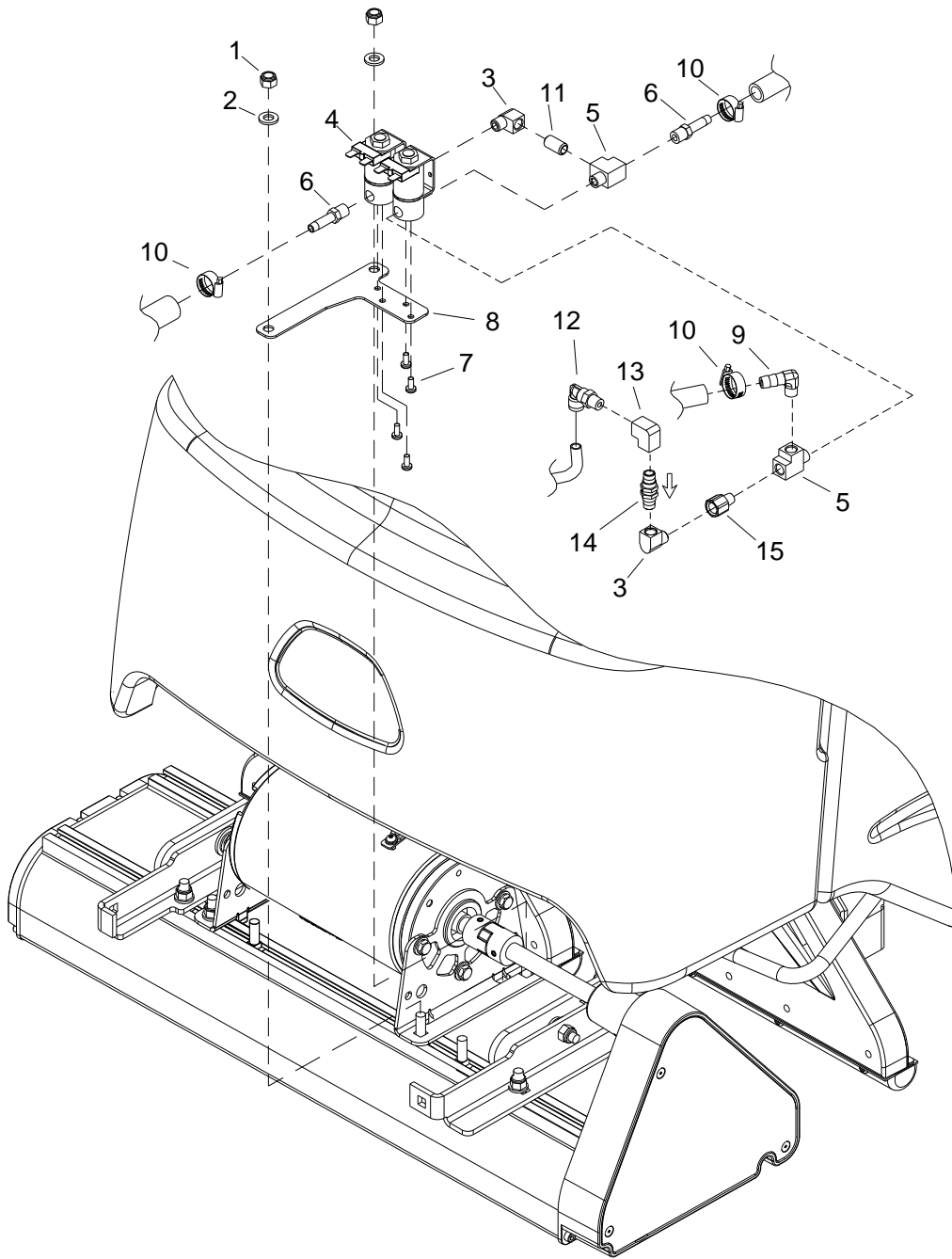

SPRAY JET VALVES - DELUXE

REF	PART NO.	PRV NO.	QTY	DESCRIPTION	SERIAL NO. FROM	NOTES:
1	86270830	57023	2	NUT, 5/16-18 HEX NYLOCK SS		
2	86010670	87029	2	WASHER, 5/16 FLAT SS		
3	86197400	31022	2	ELBOW, 1/8NPT STREET		
4	86013030	-	2	VALVE, 36VDC SOLENOID, 1/8 FPT		
5	86197750	78161	2	TEE, 1/8 NPT STREET RUN		
6	86197520	40011	2	HOSEBARB, 1/8MPT X 1/4 DL		
7	86006520	70052	4	SCR, 8-32 X 3/8 PPHMS SS		
8	86013070	-	1	BRACKET, DUO VALVE MOUNT		
9	86240610	44104	1	HOSEBARB, 1/8 MPT X 1/4 HOSE 90D		
10	86233090	20016	3	CLAMP, 1/4 ID HOSE		
11	86247720	56032	1	NIPPLE, 1/8 CLOSE		
12	86295290	-	1	ELBOW, SWIVEL, 6MM QC C 1/8 MPT		
13	86296220	-	1	ELBOW, 1/8 FPT		
14	86295300	-	1	VALVE, CHECK, 1/8 MPT		
15	86227200	04007	1	ADPTR 1/8MPTX1/8FPT BS AD		

WHEEL AND DRIVE ASSEMBLY

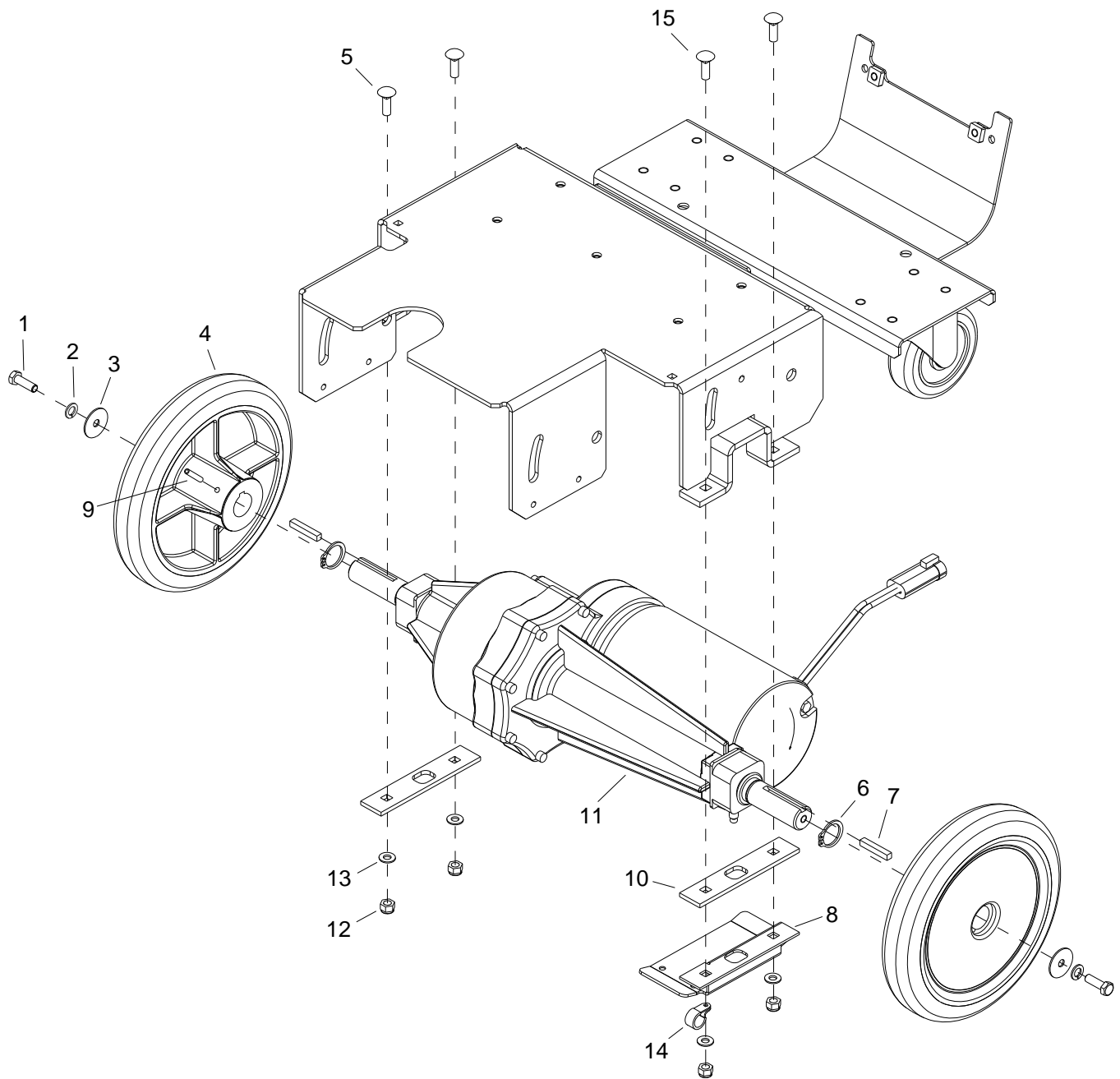

WHEEL AND DRIVE ASSEMBLY

REF	PART NO.	PRV NO.	QTY	DESCRIPTION	SERIAL NO. FROM	NOTES:
1	86276780	70728	2	SCR, 5/16-18 X 3/4 HHCS SS		
2	86279130	87083	2	WASHER, 5/16 SPLIT LOCK PLTD		
3	86279210	87102	2	WASHER, 5/16 ID X 1-1/4 OD		
4	86226060	89280	2	WHEEL, 9 X 1.6, 1.0 IN BORE		
5	86277130	70795	3	SCR, 5/16-18 X 1.00 CARRIAGE SS		
6	86272880	67270	2	RING, 1.0 EXT. SNAP HD		
7	86049230	54-500412	2	KEY, 1/4 SQ X 1.88		
8	86013630	-	1	BRKT, CABLE GUARD		
9	86277930	70119	4	SET SCR, 1/4-20 X 3/8 KCP		
10	86079580	620136	2	PLATE, TRANSAXLE SUPPORT		
11	86215050	05260	1	AXLE MTR DRIVE, 36VDC, LONG		
12	86270830	57023	4	NUT, 5/16-18 HEX NYLOCK SS		
13	86010670	87029	4	WASHER, 5/16 FLAT SS		
14	86177040	03-000149	1	CLAMP, CABLE 1-1/4 ID 5/16 BLT		
15	86277030	70780	1	SCR 5/16-18 X 1.25 CARRIAGE SS		

VACUUM SHOE

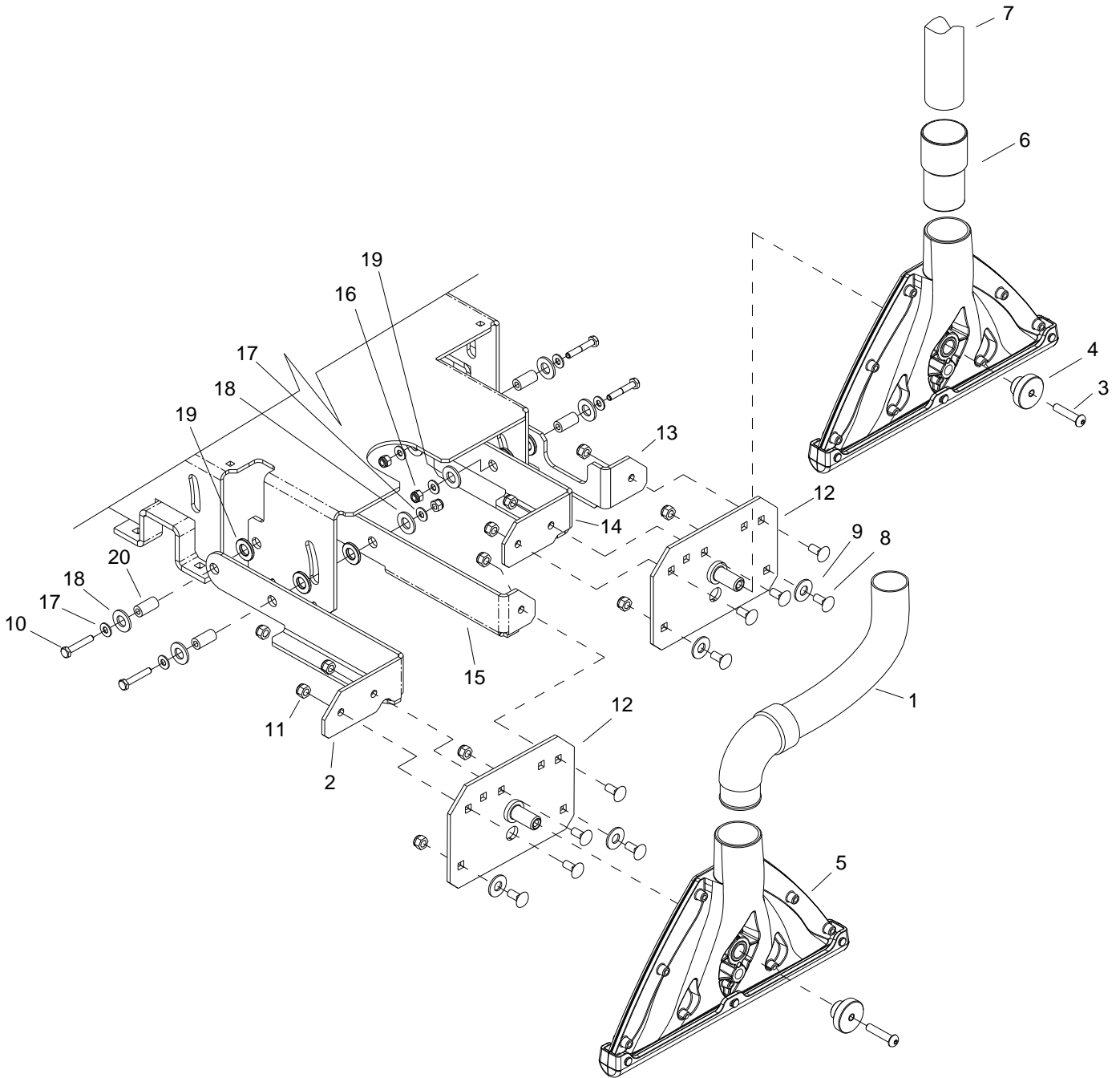

VACUUM SHOE

REF	PART NO.	PRV NO.	QTY	DESCRIPTION	SERIAL NO. FROM	NOTES:
1	86219150	39739	1	HOSE ASM, 1.5 BLK VAC X 30"		
2	86071990	141027	1	BRKT, VAC LIFT, RGT, OUTER		
3	86276650	70707	2	SCR, 5/16-18 X 1.5 BSHCS SS		
4	86219690	48080	2	KNOB, 1.5 OD X 5/16-18		
5	86296540	-	2	VAC SHOE 13 IN W/WIPER		
6	86003010	27759	1	CUFF, HOSE 1.5 BLK A 2161		
7	86001480	39315	1	HOSE, 1.5 BLK VAC X 28"		
8	86276070	70593	10	SCR, 5/16-18 X 3/4 CARRIAGE SS		
9	86010770	87143	4	WSHR, 7/16IDX1DX.08 FLT SS		
10	86273740	70010	4	SCR, 1/4-20 X 1.5 HHCS		
11	86270830	57023	10	NUT, 5/16-18 HEX NYLOCK SS		
12	86093610	620134	2	PLATE, VACUUM MTG		
13	86072020	141030	1	BRKT, VAC LIFT, LFT, OUTER		
14	86072010	141029	1	BRKT, VAC LIFT, LFT, INNER		
15	86072000	141028	1	BRKT, VAC LIFT, RGT, INNER		
16	86271870	57290	4	NUT, 1/4-20 HEX NYLOCK THIN SS		
17	86010630	87013	8	WSHR, 1/4 ID X 5/8 OD SS		
18	86259420	87232	8	WSHR, THRUST .51IDX1 ODBRO		
19	86259400	87205	8	WASHER, THRUST.51IDX1 ODBRO		
20	86228920	09140	4	BEARING, .252 ID X .503 OD X 1.0		

VACUUM SHOE

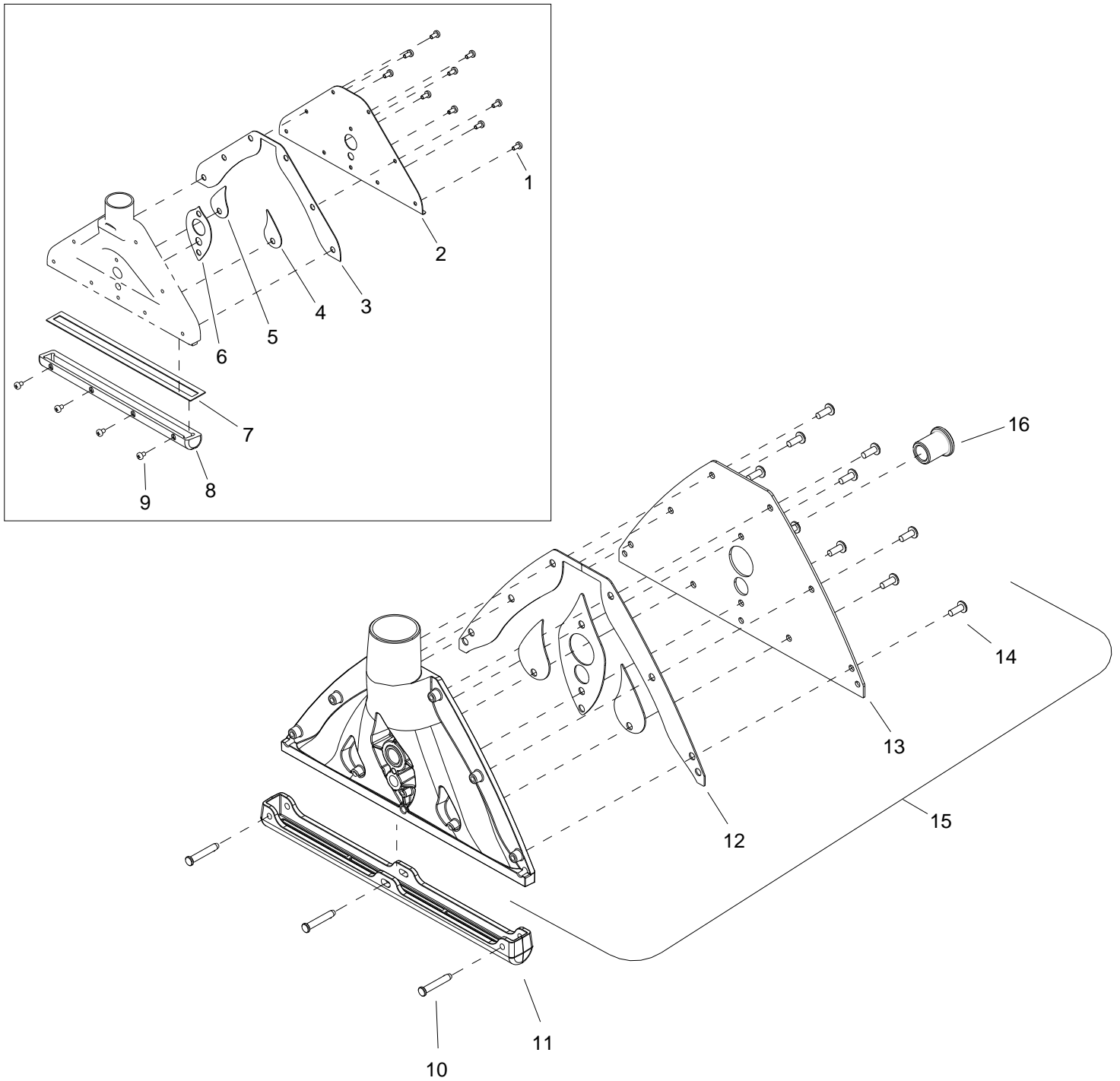

VACUUM SHOE

REF	PART NO.	PRV NO.	QTY	DESCRIPTION	SERIAL NO. FROM	NOTES:
1	86006580	70085	10	SCR, 1/4-20 X 1/2 PPHMS SS		
2	86075450	27246	1	COVER, VAC SHOE		
3	86237910	35279	1	GASKET, VAC SHOE OUTER		
4	86237920	35280	1	GASKET, 5.0 OD X 2.0 ID X .50T		
5	86237930	35281	1	GASKET, VAC SHOE RIGHT		
6	86237940	35282	1	GASKET, VAC SHOE CENTER		
7	86237950	35283	1	GASKET, VAC SHOE WIPER		
8	86259980	85012	1	WIPER, VAC SHOE		
9	86275950	70568	4	SCR, 10-24 X 3/8 PPHMS SS		
10	86293190	-	3	PIN, CLEVIS	*(5,6)	
11	86296520	-	1	WIPER, W/GASKET	*(5,6)	
12	86310750	-	1	ASSEMBLY, GASKETS, VAC SHOE	*(5,6)	
13	86296410	-	1	PLATE, VACSHOE	*(5,6)	
14	86302700	-	10	SCR, M6 X 16 PH, SS	*(5,6)	
15	86296550	-	1	VACSHOE, 13 IN	*(5,6)	
16	86296350	-	1	BUSHING, BRONZE, PM, 15.93 ID		

* SEE SERIAL NUMBER PAGE

NOTE: Two vacuum shoe assemblies per machine.

VACUUM - BASIC

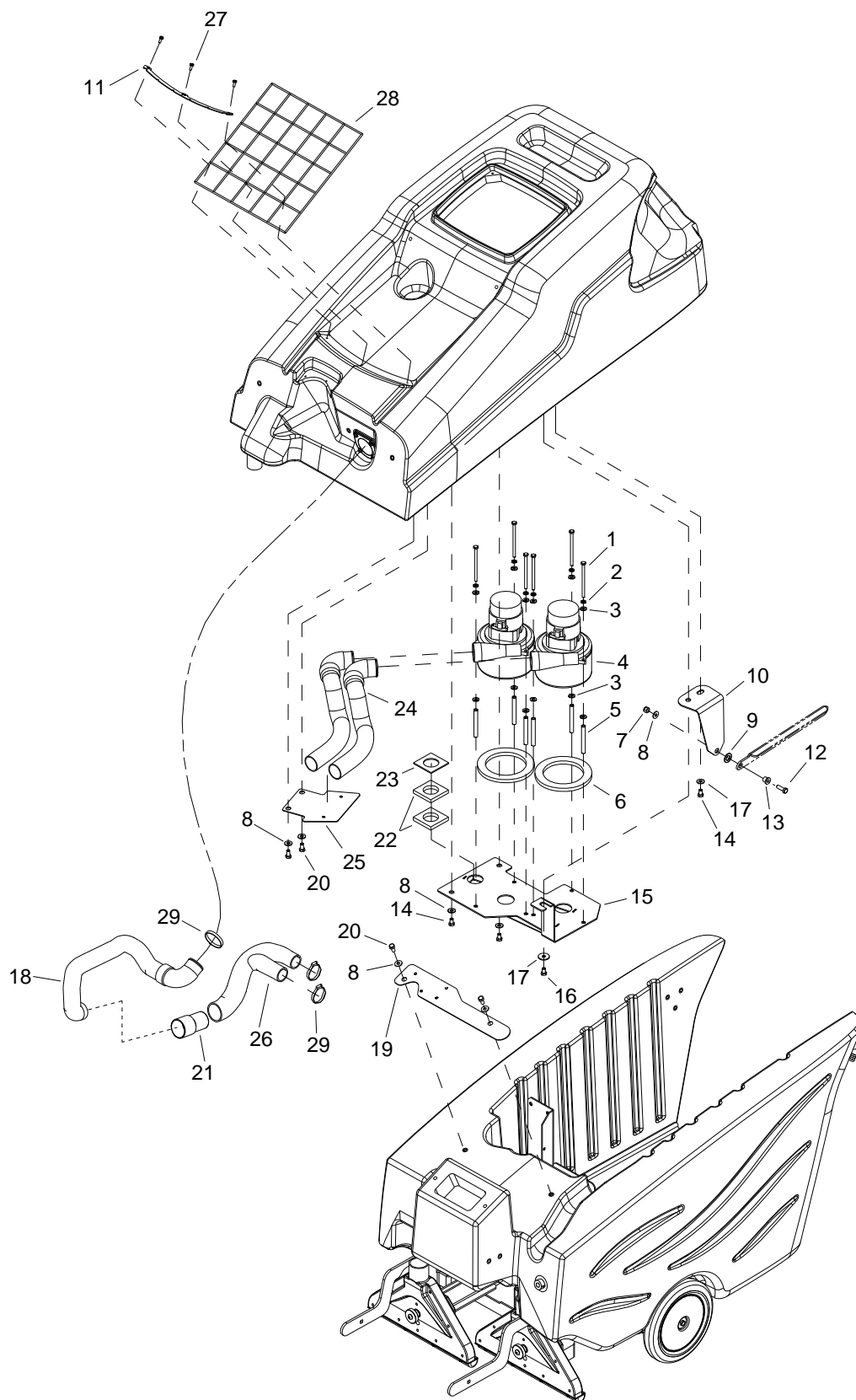

VACUUM - BASIC

REF	PART NO.	PRV NO.	QTY	DESCRIPTION	SERIAL NO. FROM	NOTES:
1	86276720	70718	6	SCR, 1/4-20 X 4.25 HHCS PLTD		
2	86010780	87162	6	WSHR, 1/4 SPLIT LOCK PLTD		
3	86010630	87013	12	WSHR, 1/4 ID X 5/8 OD SS		
4	86258480	53177	2	VAC MTR, 36VDC 5.7 3STAGE TD		
-	86135310	140686	-	BRUSH SET 24/36V VDC		
5	86011760	-	6	SPACER, .38OD X .058W X 3.2L		
6	86003760	35166	2	GASKET, VAC MTR		
7	86270830	57023	1	NUT, 5/16-18 HEX NYLOCK SS		
8	86010670	87029	7	WSHR, 5/16 FLAT SS		
9	86259410	87206	1	WSHR, THRUST .51ID X 10DX .063		
10	86011640	-	1	BRKT, PROP ROD PIVOT		
11	86292640	-	1	BRKT, CARGO NET		
12	86006560	70083	1	SCR, 5/16-18 X 1 HHCS SS		
13	86228840	09124	1	BRG, FLANGED .314IDX.502OD		
14	86277040	70781	3	SCR, 5/16-18X1/2 HHCS SS		
15	86014420	-	1	BRKT, VACUUM		
16	86276780	70728	1	SCR, 5/16-18 X 3/4 HHCS SS		
17	86279210	87102	2	WASHER, 5/16 ID X 1-1/4 OD		
18	86004370	39547	1	HOSE ASM 1.5 BLK VAC X 21		
19	86071920	141018	1	BRKT, VACUUM JUNCTION		
20	86276490	70670	4	SCR, 5/16-18 X 5/8 HHCS		
21	86003010	27759	1	CUFF, HOSE 1.5 BLK A 2161		
22	86011830	-	2	GASKET, VAC PLATE		
23	86014470	-	1	PLATE, VACUUM CONTAINMENT		
24	86004420	39609	2	HOSE ASM, 1.5 BLK VAC X 14		
25	86071890	141014	1	BRKT, VACUUM EXHAUST		
26	86075330	22111	1	COUPLER, VACUUM		
27	86006950	70532	3	SCR, 10-32 X 1/2 PPHMS BLK NP		
28	86292630	-	1	NET, CARGO		
29	86002400	20064	3	CLAMP, 2.0" WORM GEAR X.312W		

VACUUM - DELUXE

REF	PART NO.	PRV NO.	QTY	DESCRIPTION	SERIAL NO. FROM	NOTES:
1	86273810	70018	6	SCR, 1/4-20 X 1 HHCS SS		
2	86010780	87162	6	WASHER, 1/4 SPLIT LOCK PLTD		
3	86010630	87013	12	WASHER, 1/4 ID X 5/8 OD SS		
4	86258480	53177	2	VAC MOTOR, 36V 5.7 3ST TD		
-	86135310	140686	-	BRUSH SET 24/36V VDC		
5	86011760	-	6	SPACER, .38OD X .058W X 3.2L		
6	86003760	35166	2	GASKET, VAC MTR		
7	86011670	-	1	BRKT, VACUUM, PUMP		
8	86011830	-	2	GASKET, VAC PLATE		
9	86014470	-	1	PLATE, VACUUM CONTAINMENT		
10	86004420	39609	2	HOSE ASM, 1.5 BLK VAC X 14		
11	86011640	-	1	BRKT, PROP ROD PIVOT		
12	86259410	87206	1	WASHER, THRUST.51IDX10DX.063		
13	86006560	70083	1	SCR, 5/16-18 X 1 HHCS SS		
14	86228840	09124	1	BEARING, FLNGD .314IDX.502OD		
15	86279630	87212	2	WASHER, .34IDX1.13ODX.09T PLT		
16	86276490	70670	7	SCR, 5/16-18 X 5/8 HHCS SS		
17	86010670	87029	7	WASHER, 5/16 FLAT SS		
18	86270830	57023	1	NUT, 5/16-18 HEX NYLOCK SS		
19	86071890	141014	1	BRKT, VACUUM EXHAUST		
20	86306470	-	1	BRKT, VACUUM JUNCTION V		
21	86075330	22111	1	COUPLER, VACUUM		
22	86297600	-	1	HOSE ASM, 1.5 BLK VAC X 6.5		
23	86003010	27759	1	CUFF, HOSE 1.5" BLK A 2161		
24	86002400	20064	2	CLAMP, 2.0" WORM GEAR X.312W		
25	86292640	-	1	BRKT, CARGO NET		
26	86006950	70532	1	SCR, 10-32 X 1/2 PPHMS BLK NP		
27	86292630	-	1	NET, CARGO		

WIRING - BATTERY

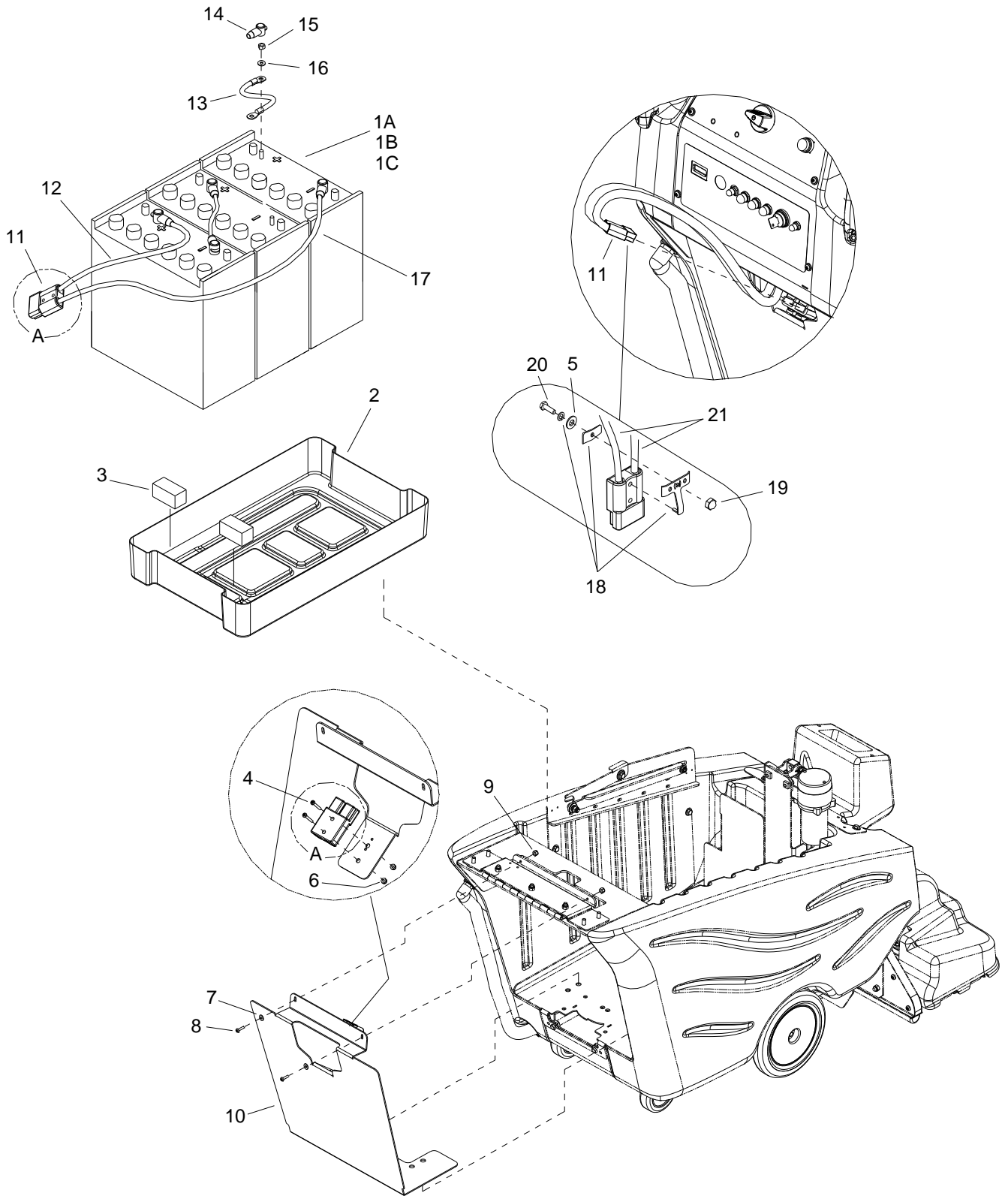

WIRING-BATTERY

REF	PART NO.	PRV NO.	QTY	DESCRIPTION	SERIAL NO. FROM	NOTES:
1A	86228410	10023	3	BATTERY, 12V, 205AH		
1B	86283410	10030	3	BATTERY, 12V, 225AH		
1C	86228430	10032	3	BATTERY, 12V AGM 198AH		
2	86088800	78945	1	TRAY, BATTERY LINER		
3	86229740	140417	2	BLOCK, 3.0 X 3.5 X 4.0		
4	86275870	70556	2	SCR, 1/4-20 X 1.5 PPHMS SS		
5	86010650	87018	1	WASHER, #10 X 9/16 OD		
6	86005810	57245	2	NUT, 1/4-20 HEX NYLOCK SS		
7	86010650	87018	1	WASHER, #10 X 9/16 OD		
8	86273980	70066	2	SCR, 10-32 X 3/4 PPHMS		
9	86270990	57090	2	NUT, 10-32 HEX NYLOCK SS		
10	86013740	-	1	PLATE, BACK, BATTERY		
11	86008760	80682	2	CONN, 175 DCA GRY W/O TERMS		
12	86260610	880836	1	WIRE, 4X25RD CTERM X 3/8RING		
13	86260200	80872	2	WIRE 4X1425BK 3/8RINGX3/8RING		
14	86008920	80889	6	BOOT, RUBBER TERM. ISOLATOR		
15	86271910	57295	6	NUT, 5/16-18 FLEXLOCK		
16	86010670	87029	6	WASHER, 5/16 FLAT SS		
17	86260230	80876	1	WIRE, 4X30 BK CTERM X 3/8RING		
18	86233360	28038	1	CLAMP, CABLE KIT SY 945		
19	86270890	57034	1	NUT, ACORN 10-32		
20	86273980	70066	1	SCR, 10-32 X 3/4 PPHMS		
21	86260320	82688	2	WIRE, 4,40BK CTERM X 5/16 RING		
-	86284090	02456	1	CHARGER 36V 20A 115V C175		NOT SHOWN FOR WET CELL BATTERIES
-	86000150	02264	1	CHARGER, 36V 21A AGM C175		NOT SHOWN FOR AGM BATTERIES

WIRING-CONTROL PANEL-BASIC

REF	PART NO.	PRV NO.	QTY	DESCRIPTION	SERIAL NO. FROM	NOTES:
1	86261210	29204	4	DIODE ASM, 76008 X 76008		
2	86261250	29273	3	DIODE ASM, FAST RECOVERY		
3	86013210	-	1	HARNESS BASIC EXTRACTOR PANEL		
4	86013750	-	1	HARNESS BASIC VAC, EXT.		

WIRING-CONTROL PANEL-DELUXE

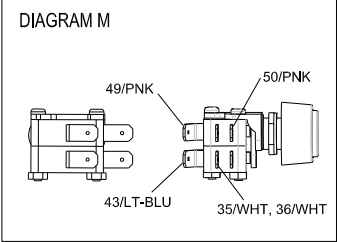
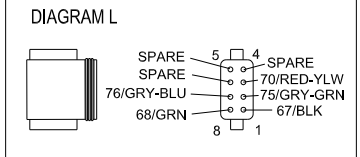
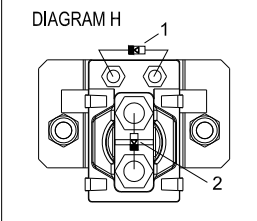
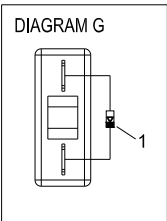
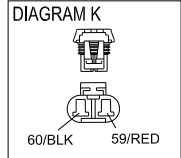
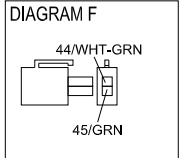
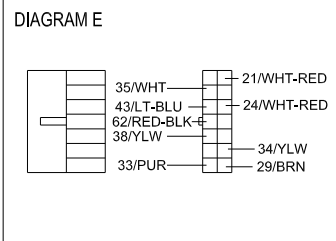
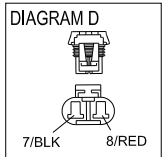
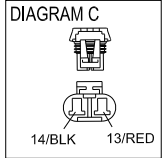
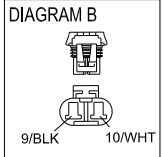
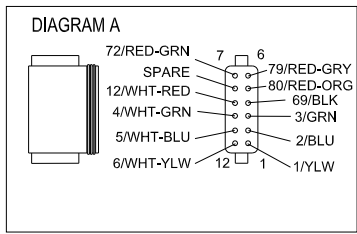
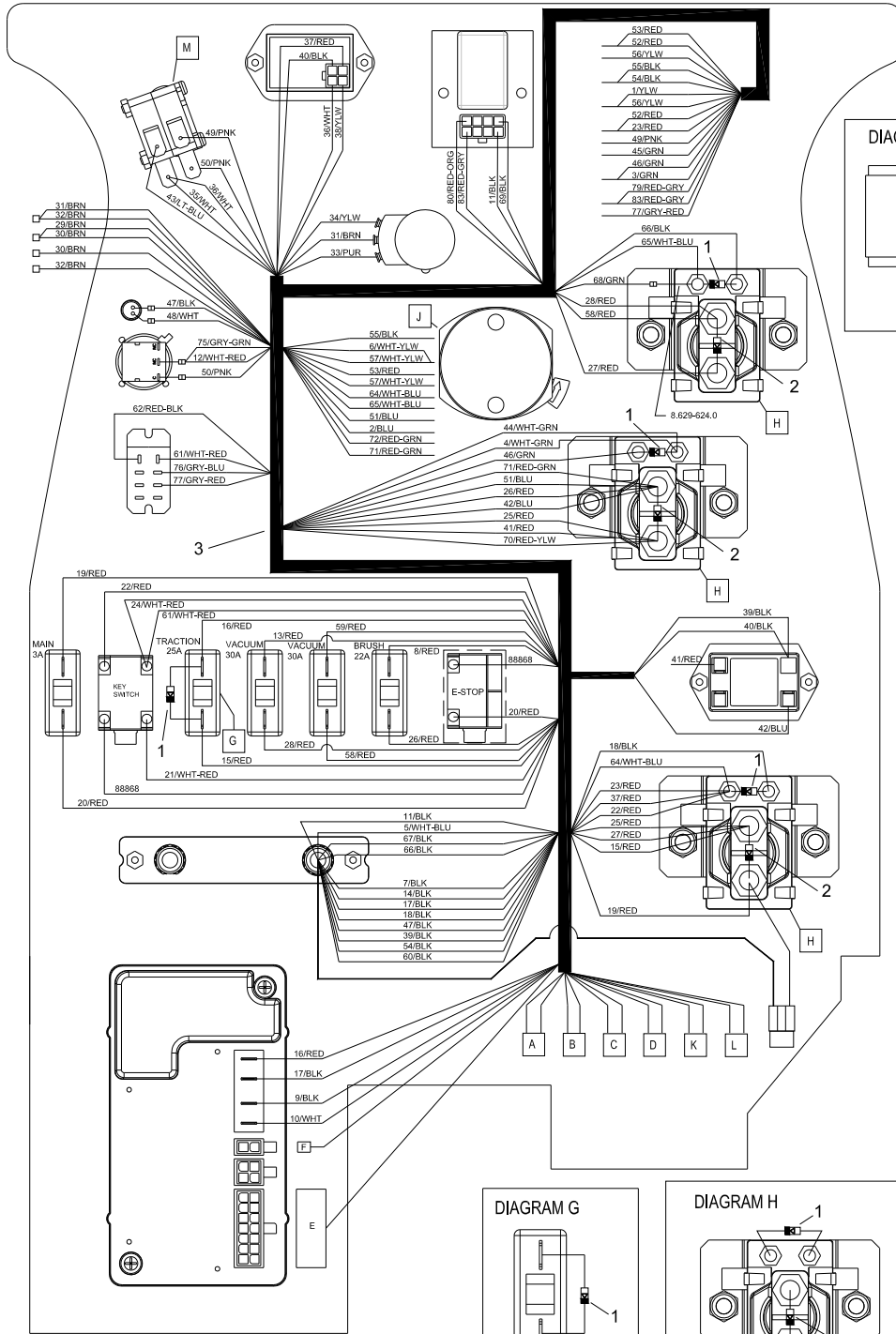

DIAGRAM J

1	52/RED, 53/RED
2	56/YLW
3	55/BLK
4	6/WHT-YLW, 57/WHT-YLW
5	54/BLK, 55/BLK
6	1/YLW, 56/YLW
7	53/RED
8	57/WHT-YLW
9	23/RED, 52/RED
10	49/PNK
11	64/WHT-BLU
12	65/WHT-BLU
13	45/GRN
14	3/GRN, 46/GRN
15	51/BLU
16	2/BLU
17	79/RED-GRY, 83/RED-GRY (P/N 8.629-610.0)
18	77/GRY-RED
19	72/RED-GRN
20	71/RED-GRN

INDICATES OPTIONAL EQUIPMENT

WIRING-CONTROL PANEL-DELUXE

REF	PART NO.	PRV NO.	QTY	DESCRIPTION	SERIAL NO. FROM	NOTES:
1	86261210	29204	4	DIODE ASM, 76008 X 76008		
2	86261250	29273	3	DIODE ASM, FAST RECOVERY		
3	86013210	-	1	HARNESS BASIC EXTRACTOR PANEL		
4	86295170	-	1	HARNESS, DELUXE EXTRACT PANEL		

WIRING-MAIN HARNESS-BASIC

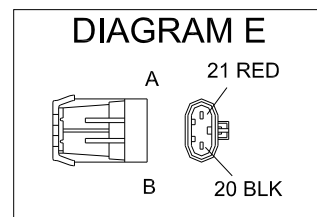
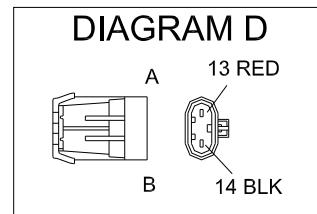
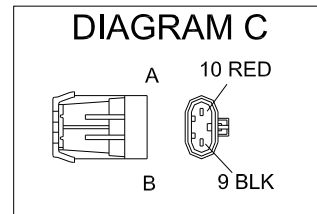
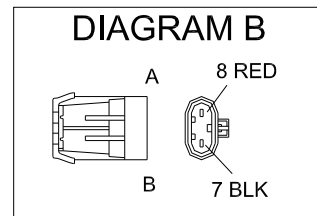
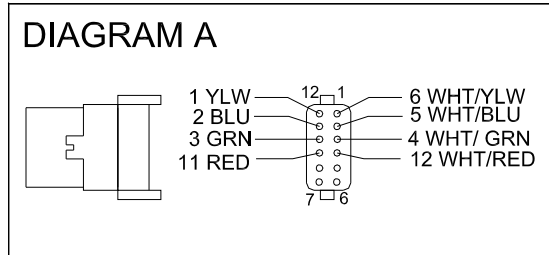
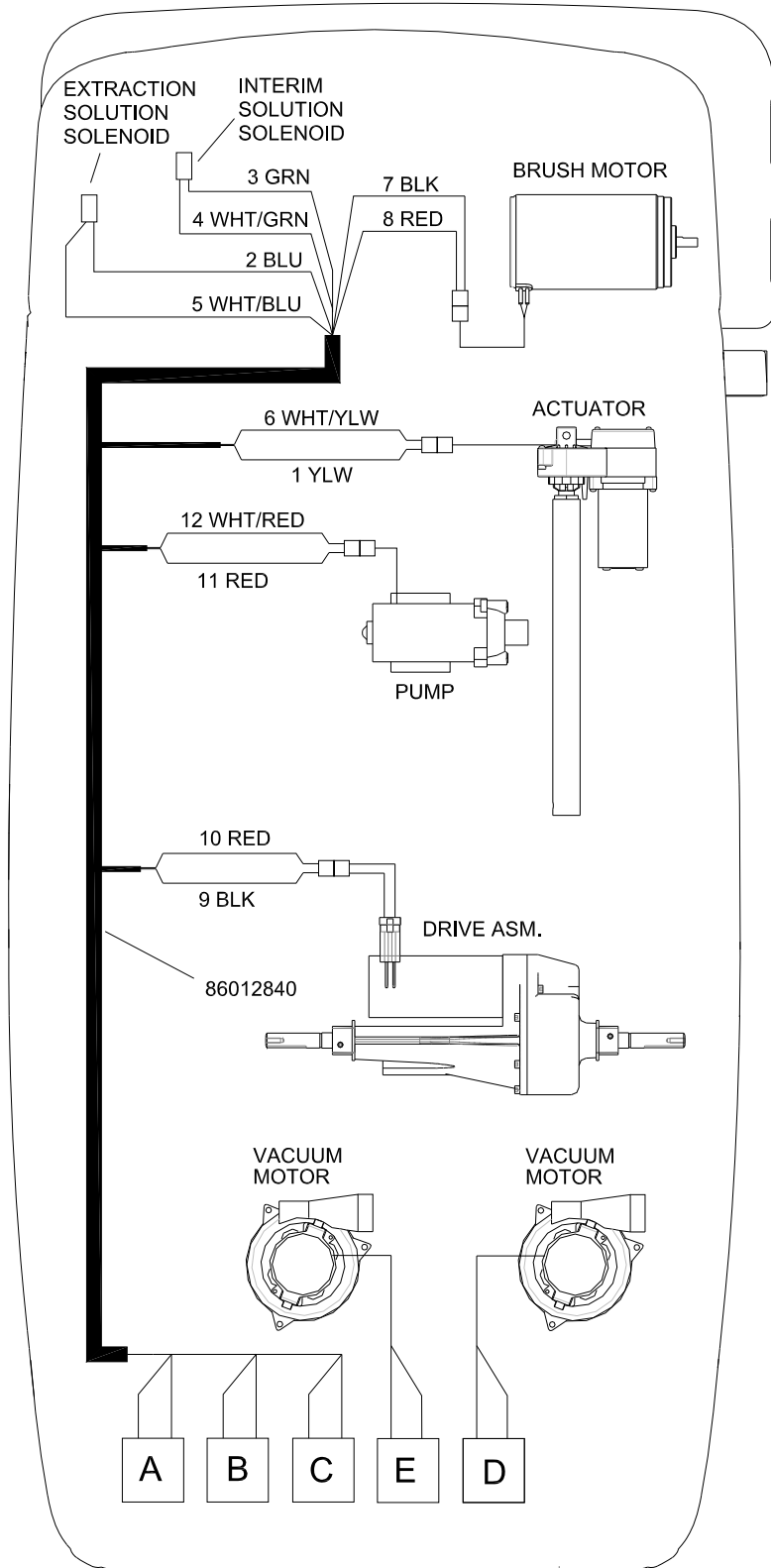

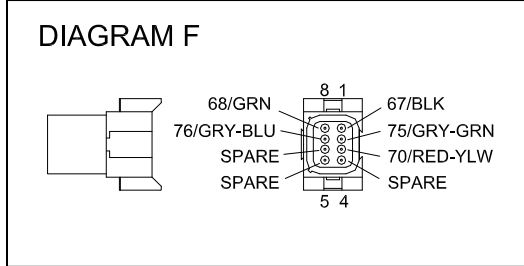
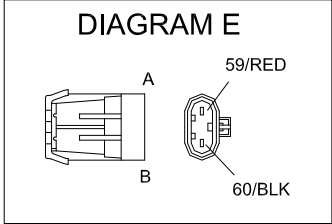
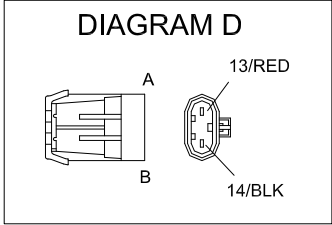
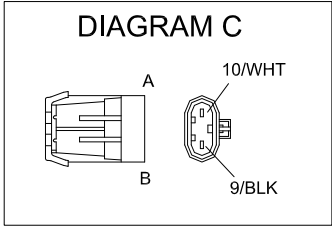
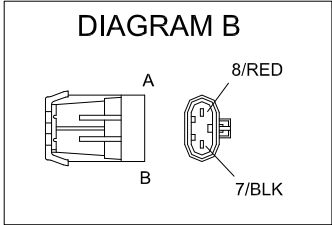
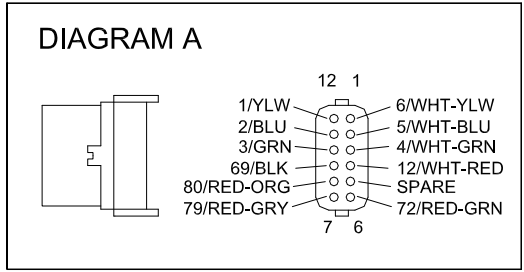
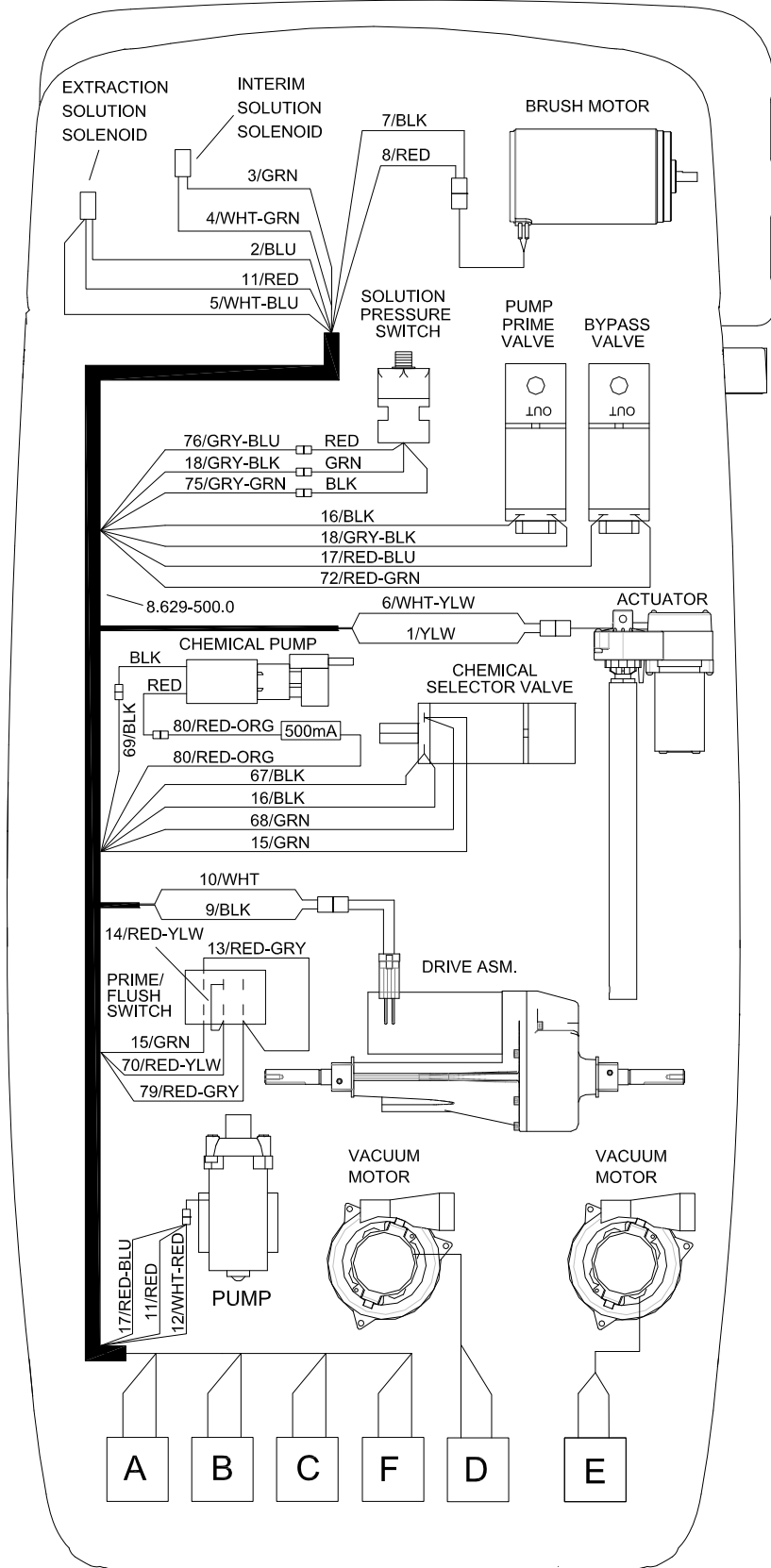

WIRING DIAGRAM – BASIC

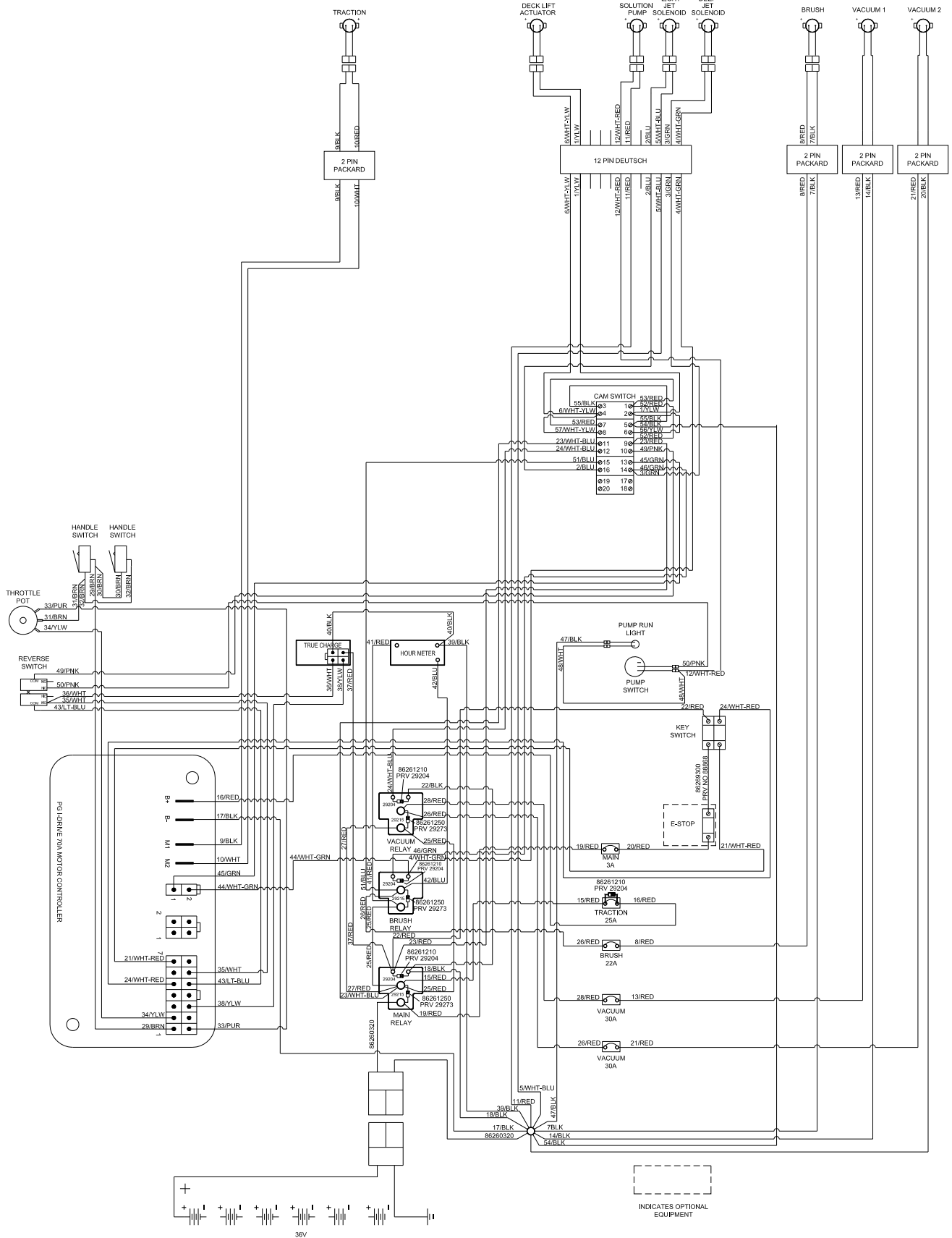

HOSE DIAGRAM - BASIC

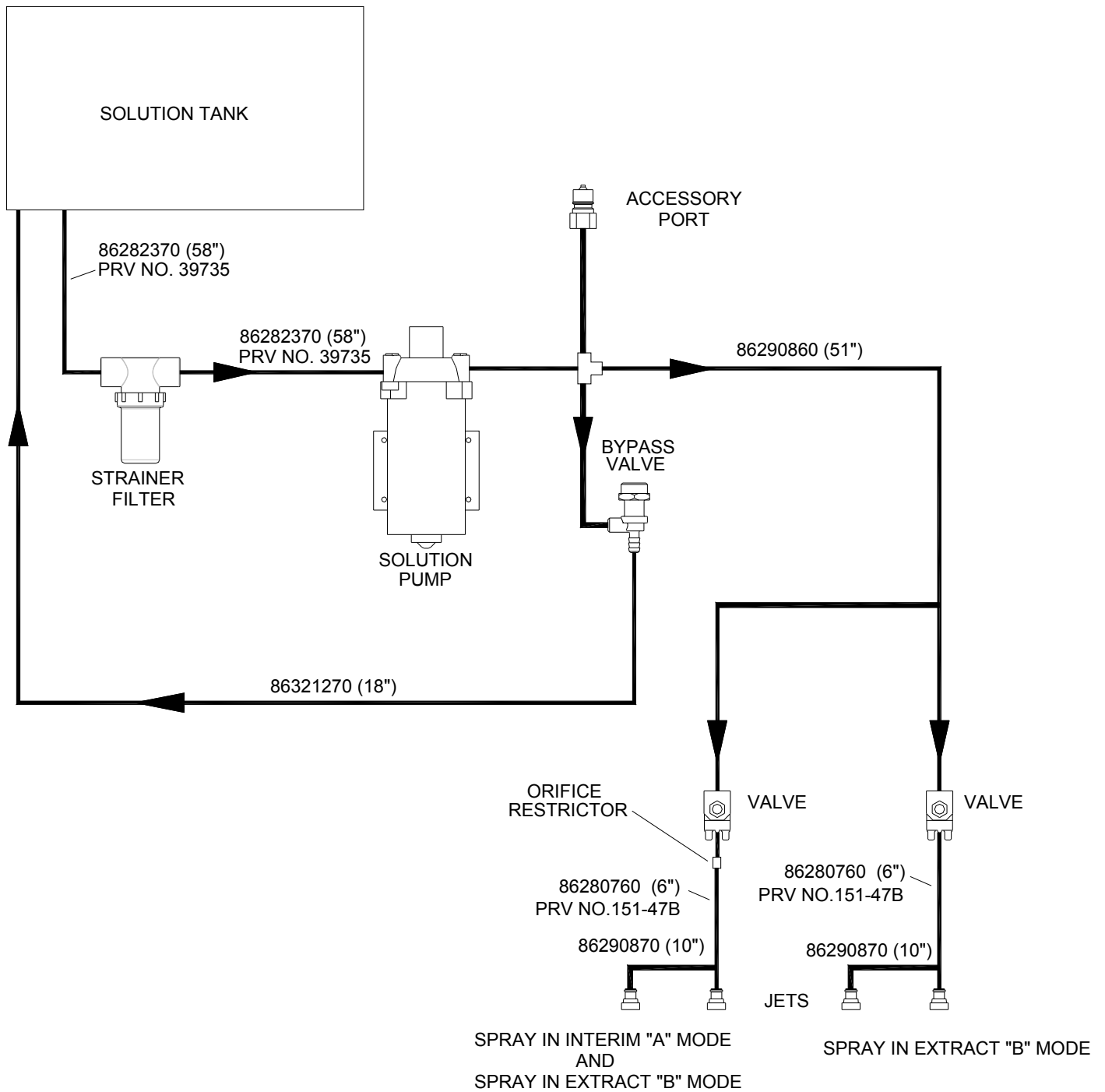

HOSE DIAGRAM – DELUXE

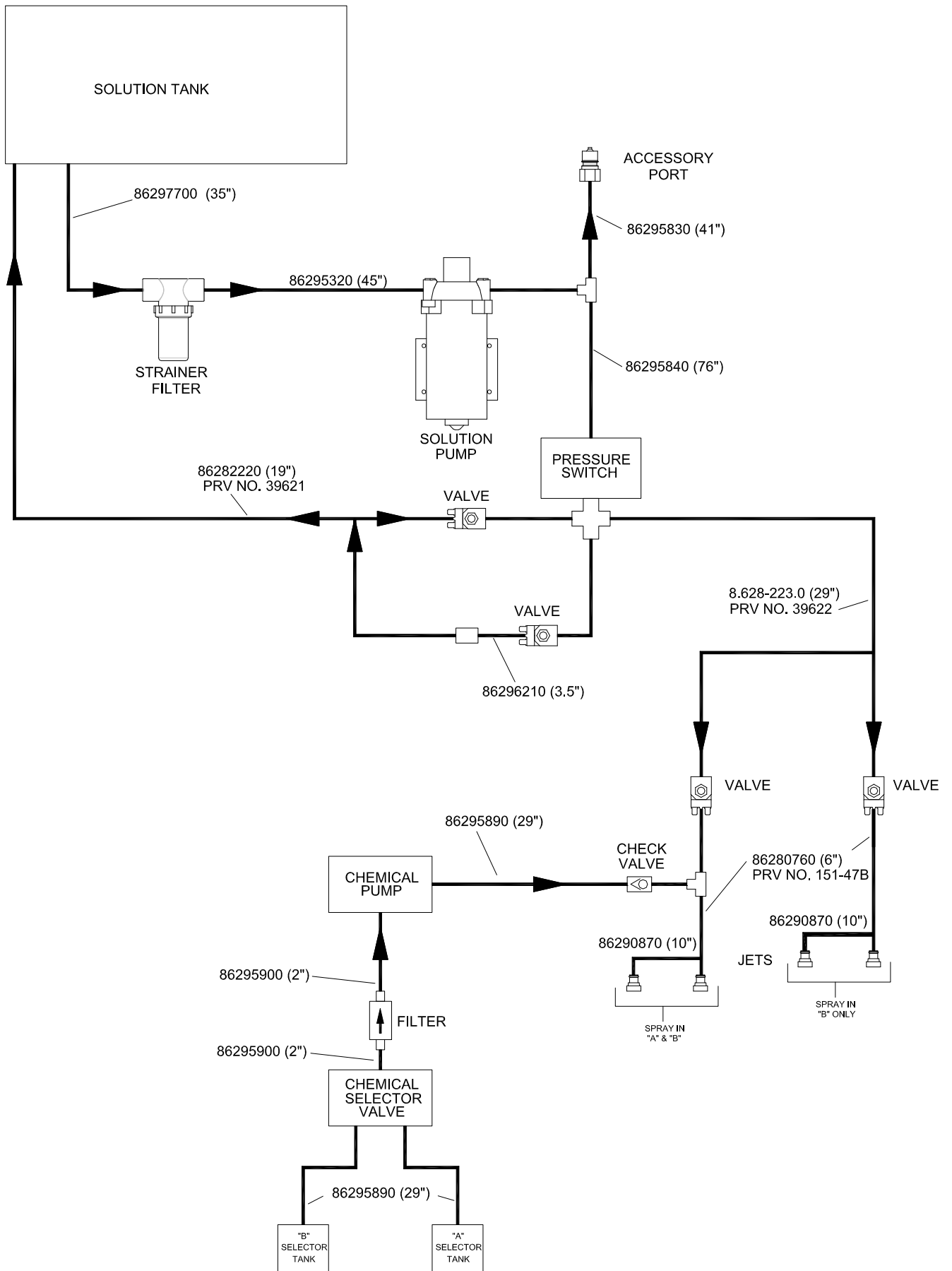

SUGGESTED SPARE PARTS

PART NO.	PRV NO.	DESCRIPTION	SERIAL NO. FROM	NOTES:
86002000	14717	BREAKER, 3 AMP		
86001920	14607	BREAKER, 25A VDC CIRCUIT		
86001910	14606	BREAKER, 30A 50VDC CIRCUIT		
86230680	12532	BRUSH, EXTRACTOR 24		
86251360	67166	RELAY, 36VDC 100A		
86007190	72161	SWITCH KEY DPST		
86014690	-	SWITCH, ROTARY CAM, 4 POS		
86199840	090-12A	FLOAT SCREEN CAGE ASSY		
86013030	-	VALVE, 36VDC SOLENOID, 1/8 FPT		
86012550	-	JET, PROMAX 11001		
86013200	-	JET, MINI PROMAX 11004		
86004570	44067	JET BODY, MINI PROMAX BODY		
86215250	11049	BELT, 2S 5MM HTD, 15W, 128T		
86224630	730380	SPRING, BRUSH CLIP		
86217260	22106	COUPLER, SPIDER		
86230080	141044	BREAKER, 22A 250VAC, 50VDC		
86257180	72207	SWITCH, MOMENTARY, DPDT, WHITE		
86257150	72197	SWITCH, SPDT P-BUTTON		
86006310	66335	POTENTIOMETER, 50K OHMS		
86004010	35274	GASKET, DOME EDGE		
86004440	39717	CAP, DRAIN HOSE		
86012760	-	STRAINER, 1/2 FPT, 80 MESH		
86005870	59021	O-RING, FILTER SEAL RON-VIK		
86296520	-	WIPER, 13IN, W/GASKET		
86261210	29204	DIODE ASM, 76008 X 76008		
86003410	29215	DIODE ASM, 76075 X 76075		
86296100	-	ASM, DC CONVERTER		DELUXE ONLY
86007180	72160	SWITCH E-STOP		DELUXE ONLY
86251410	67506	RELAY 15 AMP 36V MIN.		DELUXE ONLY
86217270	22110	COUPLER ACC PORT VACUUM		DELUXE ONLY
86295160	-	GASKET ACC PORT COVER		DELUXE ONLY
86295310	-	CAP DISPENSING, 6.5 TUBE		DELUXE ONLY
86236590	34448	FOOT FILTER		DELUXE ONLY
86295280	-	CAP STORAGE		DELUXE ONLY
86293720	-	VALVE 3-WAY 36VDC		DELUXE ONLY
86295290	-	ELBOW SWIVEL, 6MM QCX1/8 NPT		DELUXE ONLY
86297830	-	SWITCH ASM PRESSURE		DELUXE ONLY
86295300	-	VALVE CHECK, 1/8 MPT		DELUXE ONLY
86011830	-	GASKET VAC PLATE		DELUXE ONLY
86295330	-	CAP, DISPENSING, 9.50 TUBE		DELUXE ONLY

ACCESSORIES

PART NO.	PRV NO.	DESCRIPTION
86292800	-	JET, MINI PROMAX 11003
86002460	22026	COUPLER, 1.5 VAC HOSE
86000750	04086	ADAPTER, 1/8 TO 1/4 QUICK DISCONNECT, SOLUTION



VOYAGER
DUO

OPTIONS

BATTERY CART

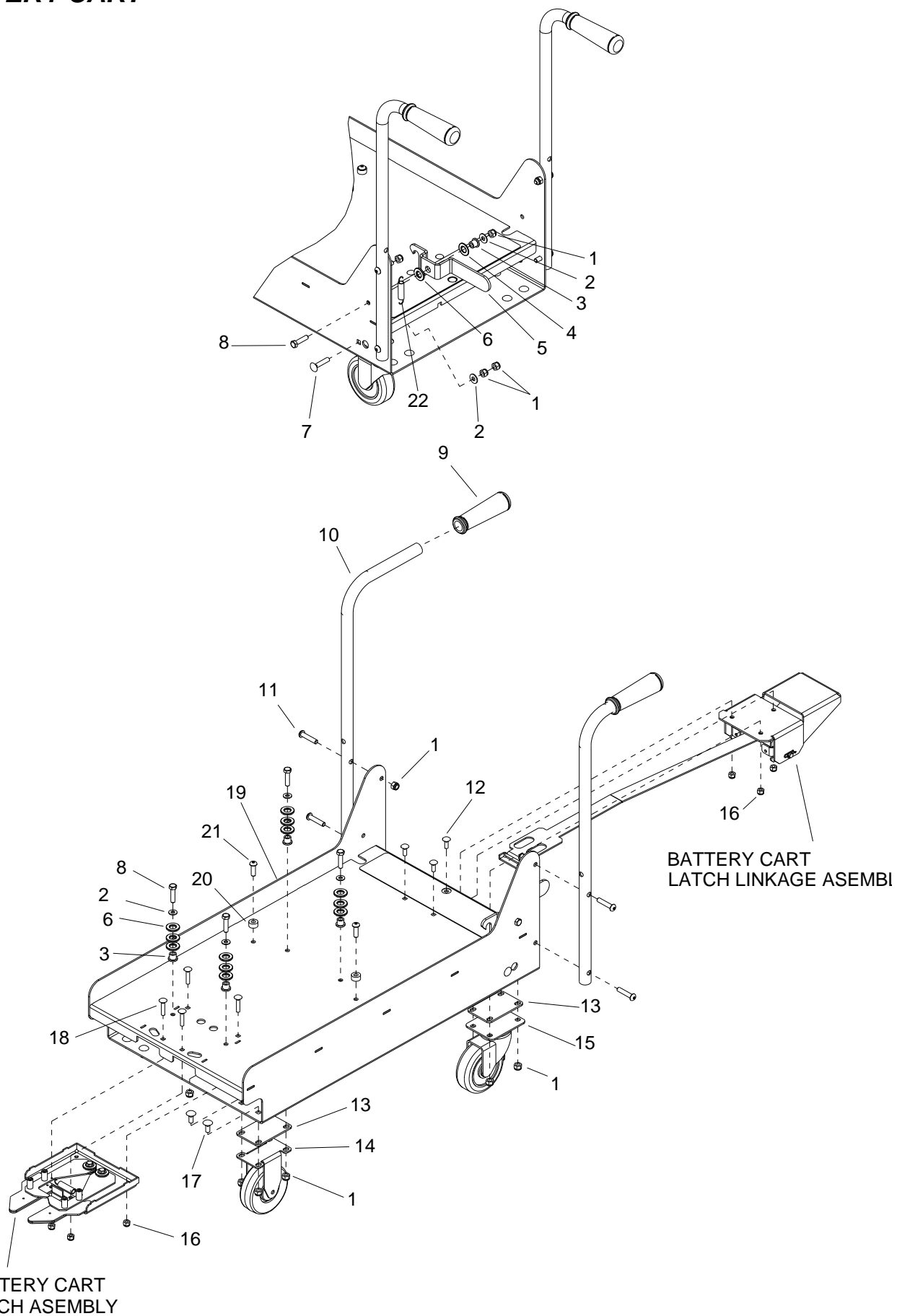

BATTERY CART

SREF	PART NO.	PRV NO.	QTY	DESCRIPTION	SERIAL NO.	NOTES:
1	86270830	57023	29	NUT, 5/16-18 HEX NYLOCK SS		
2	86010670	87029	6	WASHER, 5/16 FLAT SS		
3	86228840	09124	5	BEARING, FLANGED .314 ID X .502 OD		
4	86259410	87206	1	WASHER, THRUST .51 ID X 1 OD X .063		
5	86068490	140019	1	BRKT, TRAY CATCH		
6	86259400	87205	13	WASHER, THRUST .51 ID X 1 OD BRP		
7	86277470	70848	1	SCR, 5/16-18 X1.5 CARRIAGE SS		
8	86007020	70673	5	SCR, 5/16-18 X 1.25 HHCS SS NP		
9	86004070	36196	2	GRIP, POLISHER HANDLE		
10	86076600	38318	2	HANDLE, BATTERY CART		
11	86276650	70707	4	SCR, 5/16-18 X 1.5 BSHCS SS		
12	86276950	70772	3	SCR, 1/4-20 X 3/4 CARRIAGE SS		
13	86078890	620020	4	PLATE, CASTER SPACER		
14	86232590	18032	2	CASTER, 4" HARD RUBBER RIGID		
15	86199430	040-03	2	CASTER SWIVEL 4" 250# CPCTY		
16	86005810	57245	7	NUT, 1/4-20 HEX NYLOCK SS		
17	86276070	70593	16	SCR, 5/16-18 X 3/4 CARRIAGE SS		
18	86276330	70634	4	SCR, 1/4-20 X 1.25 CARRIAGE BZ		
19	86292880		1	HOUSING, BATTERY CART		
20	86254290	730338	2	SPACER, 10OD X .343 ID, .5 LG		
21	86006930	70514	2	SCR, 5/16-18 X 1.00 BSHCS SS		
22	86255060	73426	1	SPRING, EXT .43D X 2.50L X .047W		

BATTERY CART – LATCH AND LATCH LINKAGE

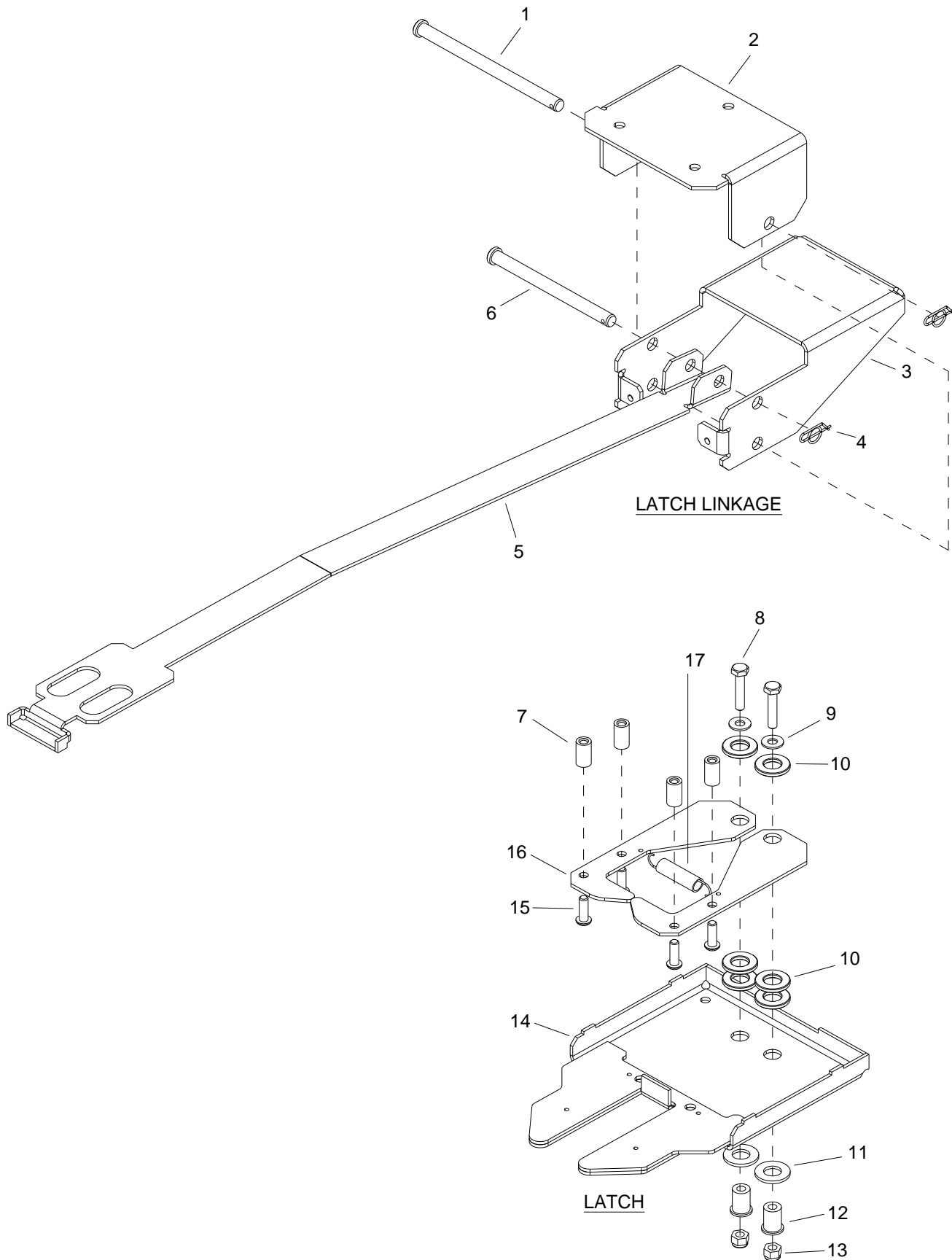

BATTERY CART- LATCH AND LATCH LINKAGE

REF	PART NO.	PRV NO.	QTY	DESCRIPTION	SERIAL NO. FROM	NOTES:
1	86008860	80808	1	PIN, CLEVIS 3/8 X 5.5 PLTD		
2	86292870	-	1	BRKT, PEDAL, BATTERY CART		
3	86292860	-	1	PEDAL, BATTERY CART		
4	86008670	80606	2	COTTER, 3/8" RING		
5	86292850	-	1	LINKAGE, LATCH, BATTERY CART		
6	86249060	82061	1	PIN, CLEVIS 3/8 X 4.63 PLTD		
7	86298200	-	4	STANDOFF, .43 OD, 1/4-20 X .75 L		
8	86273820	70019	2	SCR, 1/4-20 X 1.25 HHCS SS		
9	86010630	87013	2	WASHER, 1/4 ID X 5/8 OD SS		
10	86259400	87205	6	WASHER, THRUST .51 ID X 1 OD BRO		
11	86259420	87232	2	WASHER, THRUST .51 ID X 1 OD BRO		
12	86228900	09138	2	BEARING FLANGED, .252 ID X .503 OD		
13	86005810	57245	2	NUT, 1/4-20 HEX NYLOCK SS		
14	86011270	-	1	COVER, LATCH, BATTERY CART		
15	86275460	70481	4	SCR, 1/4-20 X 3/4 BHCS BLK		
16	86292980	-	2	LATCH, BATTERY CART		
17	86255060	73426	1	SPRING, EXT .43D X 2.50L X .047W		

BATTERY CART – TRAY

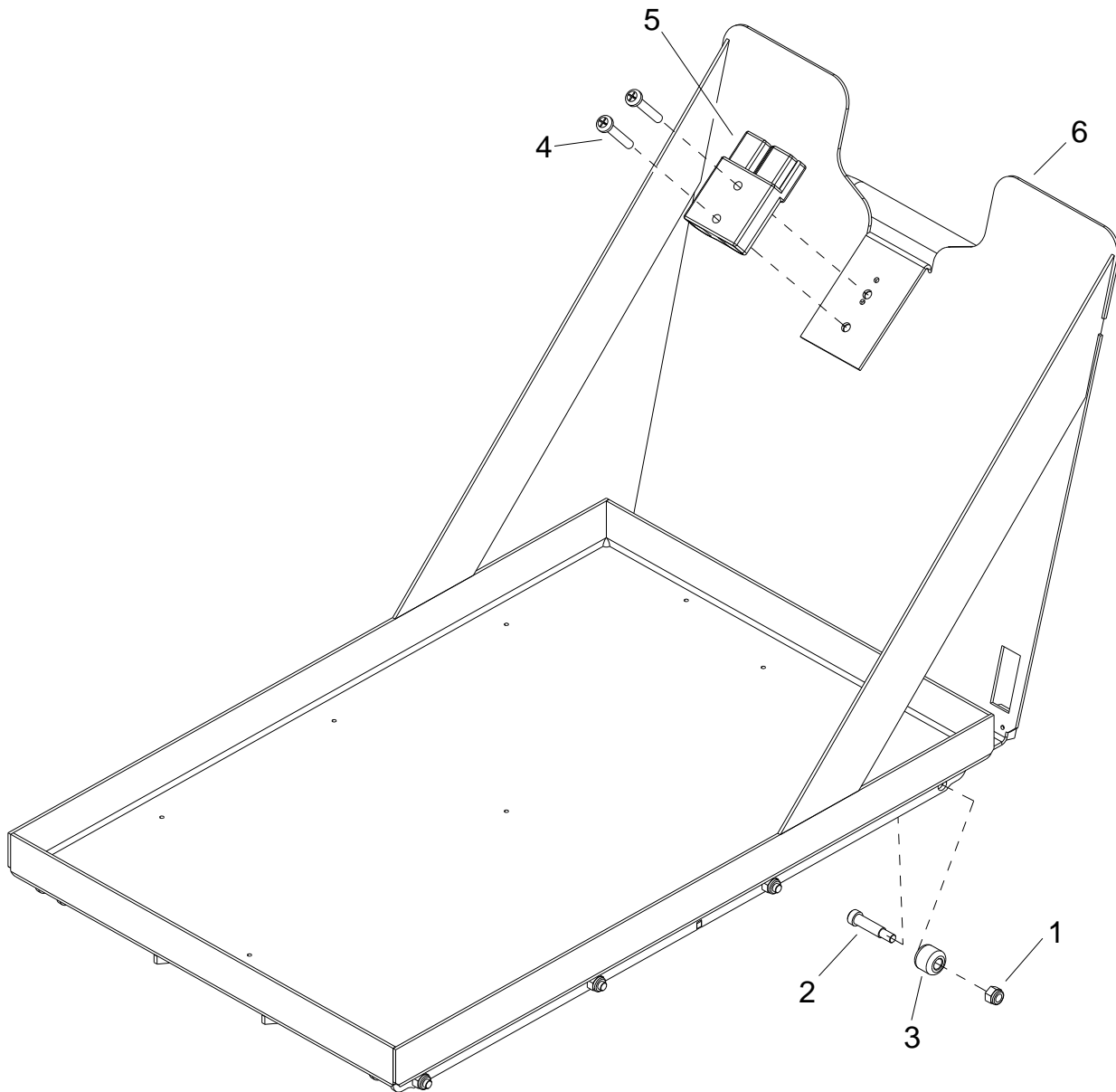

BATTERY CART- TRAY

REF	PART NO.	PRV NO.	QTY	DESCRIPTION	SERIAL NO. FROM	NOTES:
1	86005810	57245	10	NUT, 1/4-20 HEX NYLOCK SS		
2	86278150	70117	8	SHOULDER BOLT, 5/16 OD X 1.0 L		
3	86281060	89265	8	WHEEL, BATTERY TRAY		
4	86275870	70556	2	SCR, 1/4-20 X 1.5" PPHMS SS		
5	86008760	80682	1	CONN, 175 DCS GRY W/O TERMS		
6	86011530	-	1	BATTERY TRAY, WELDMENT		

BATTERY EXCHANGE OPTION

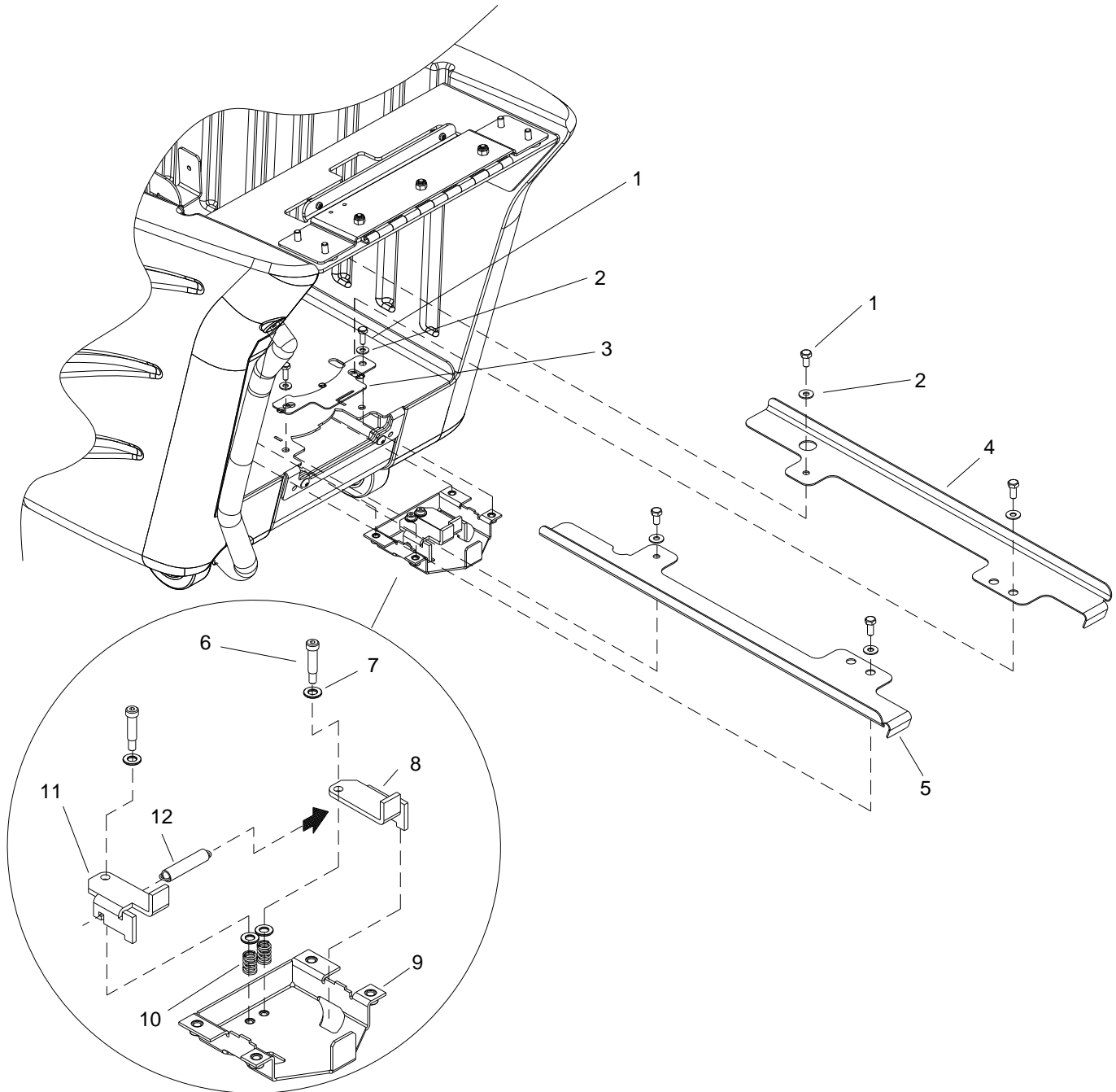

BATTERY EXCHANGE OPTION

REF	PART NO.	PRV NO.	QTY	DESCRIPTION	SERIAL NO. FROM	NOTES:
1	86276780	70728	8	SCR, 5/16-18 X 3/4 HHCS SS		
2	86010670	87029	8	WASHER, 5/16 FLAT SS		
3	86290220	-	1	PLATE, OPTION, CART LATCH		
4	86011300	-	1	GUIDE, BATTERY TRAY, RIGHT		
5	86011280	-	1	GUIDE, BATTERY TRAY, LEFT		
6	86278150	70117	2	SHOULDER BOLT, 5/16 OD X 1.0 L		
7	86290510	-	4	WASHER, THRUST .315 ID X .63 T		
8	86292830	-	1	LATCH, TRAY STOP, RIGHT		
9	86292820	-	1	COVER, LATCH, CART		
10	86290500	-	2	SPRING, COMP .48OD .88L .063W		
11	86292840	-	1	LATCH, TRAY STOP, LEFT		
12	86226780	73044	1	SPRING, EXT .44D X 2.25L X .054W		

EMERGENCY STOP-OPTION

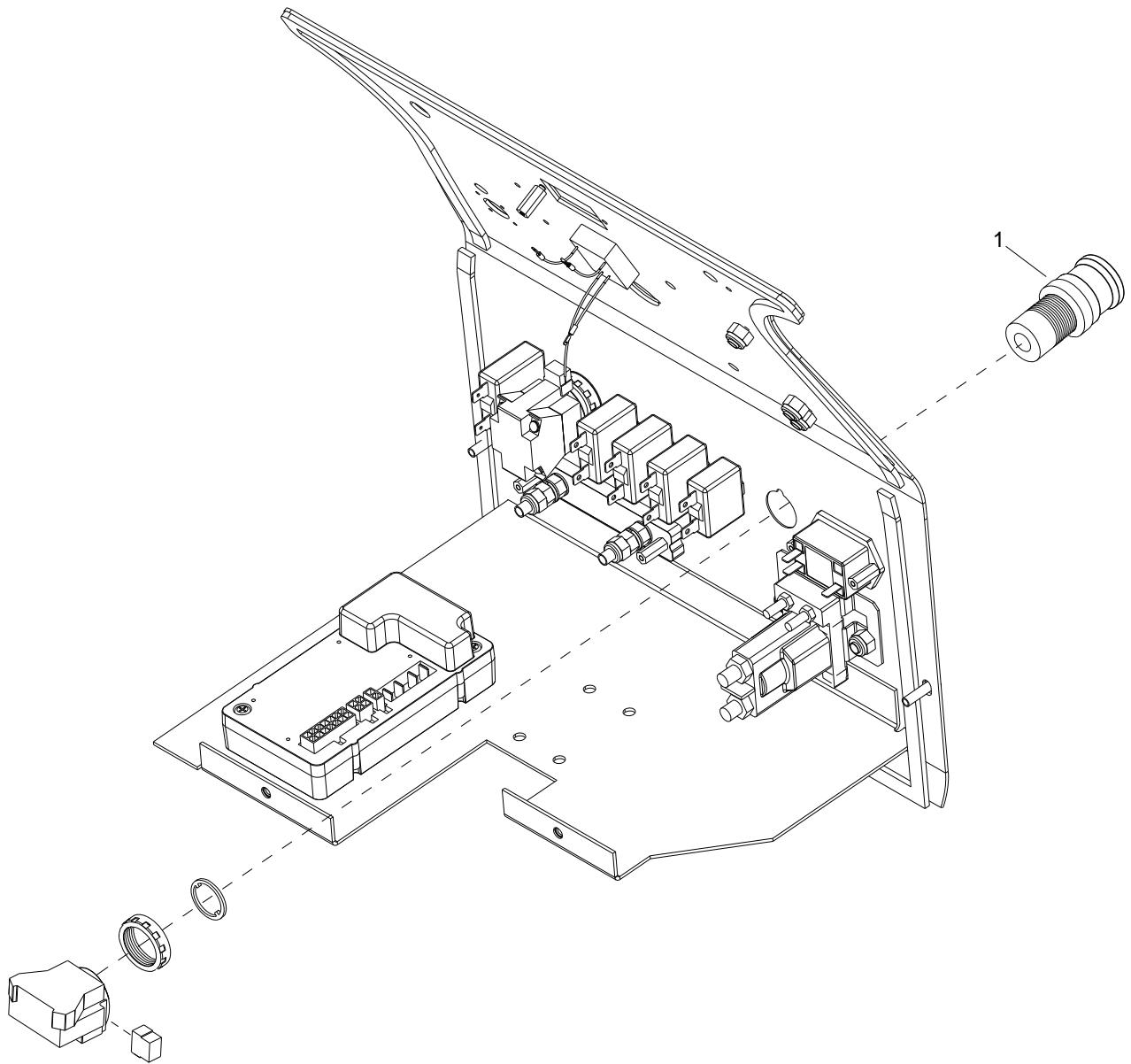

EMERGENCY STOP - OPTION

REF	PART NO.	PRV NO.	QTY	DESCRIPTION	SERIAL NO. FROM	NOTES:
1	86007180	72160	1	SWITCH, EMERGENCY STOP		
2	86299300	88868	1	WIRE, 16" RED/18 STRIPX STRIP		NOT SHOWN

SERIAL NUMBERS

REF. NO.	MODEL: SERIAL #:
1	VOYDU: 10086130000034
2	VOYXDU: 10086150000035
3	VOYDUX: 10086170000002
4	VOYXDUX: 10086190000004
5	VOYDU: 10086130000059
6	VOYXDU: 10086150000048